

ASSEMBLY INSTRUCTIONS

BENCH IT-140709T

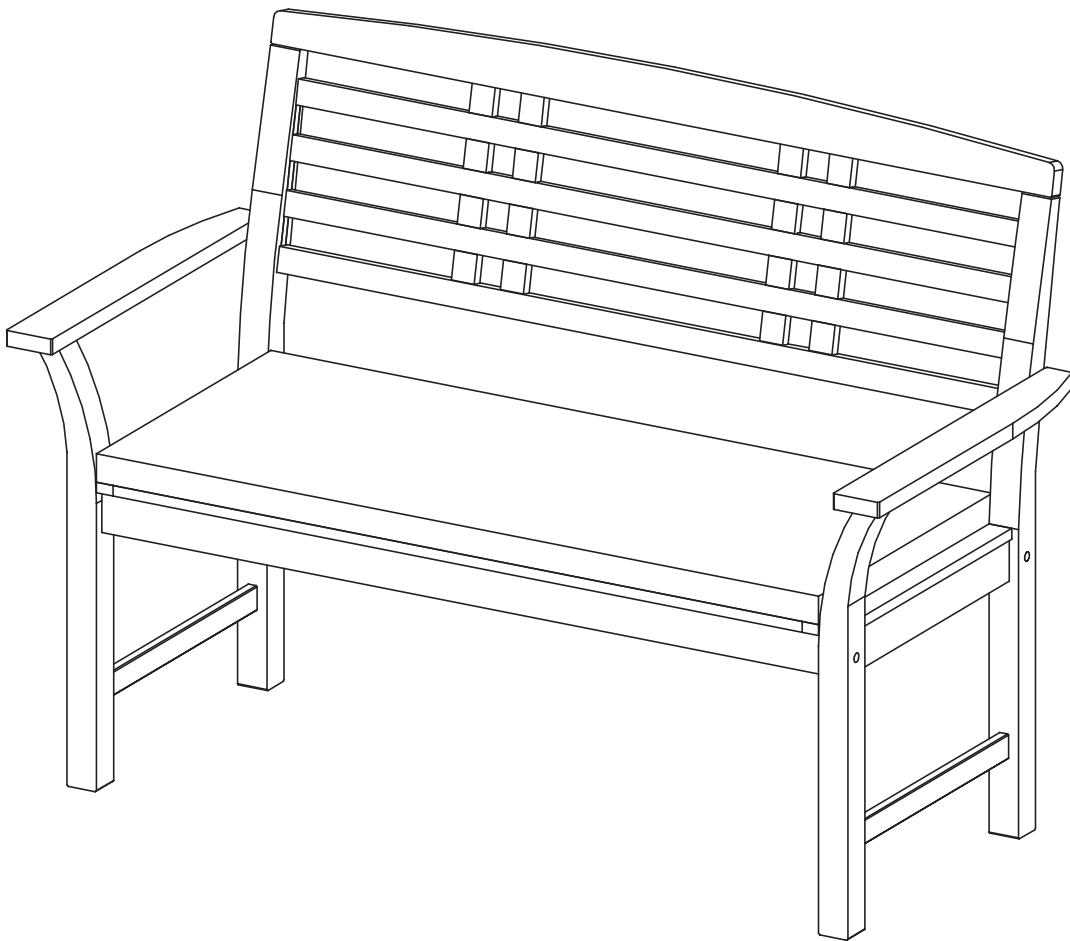

CUSTOMER SERVICE INFORMATION

Please do not return to the store. If any pieces are missing call our toll free number at 1-888-287-4275 from 9:00 am to 5.00 pm CST (Monday to Friday) for replacement parts. For faster service, have the style number handy when calling.

GENERAL INFORMATION & TIPS

1. Please read the assembly instructions prior to assembling the Bench.
2. To avoid damage, assemble the bench on a non-abrasive surface such as carpet.
3. Make sure all bolts tightly fastened before the table is used.
4. This bench is not for commercial use.

Please make sure you have all parts before beginning assembly. Please wait until all steps are completed before tightening bolts.

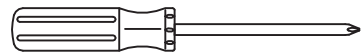

1. 8" Philips screwdriver
- For tightening all bolts and screws.



2. Rubber Mallet
- For tapping in the wooden caps.

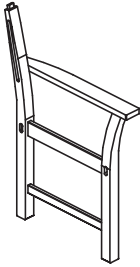
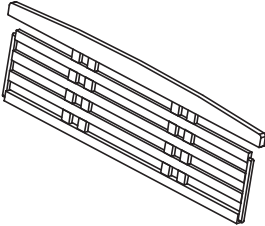
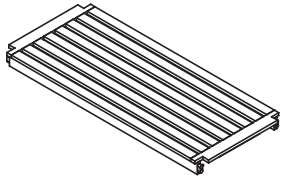
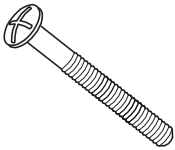
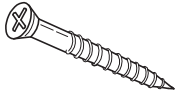

PARTS AND HARDWARE LIST

A1. Right Side frame	A2. Left Side Frame	B. Back Rest	C. Seat
			
QTY: 1 pc	QTY: 1 pc	QTY: 1 pc	QTY: 1 pc
D. Bolt 1 3/4"	E. Screw 5/8"	F. Wooden cap	
			
QTY: 4 pcs + 1	QTY: 2 pcs + 1	QTY: 4 Pcs + 1	

STEP 1

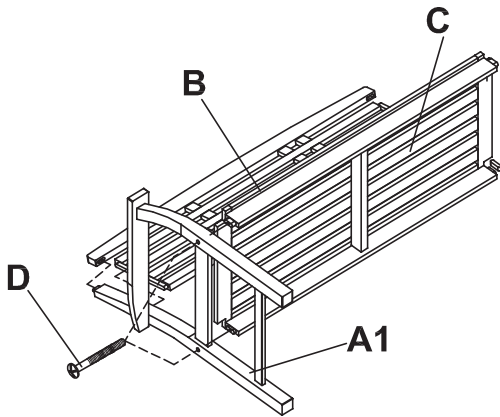

Attach back support (B) and seat (C) into right side frame (A1)

STEP 2

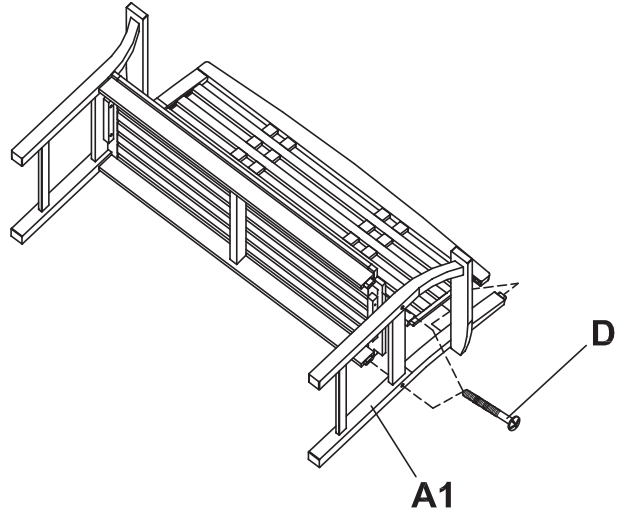

Attach left side frame (A2) to the assembly from step 1 using 1 3/4" bolts (D). Tighten all bolts using screwdriver.

STEP 3

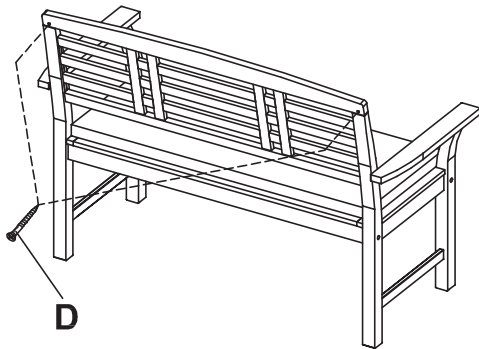

Attach the table top to previous assembly. Secure with 1 3/4" bolt (D) and 5/8" screw onto back rest assembly. Tighten all bolts and screw using screwdriver.

STEP 4

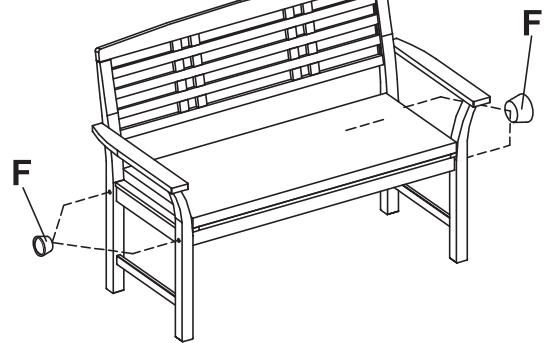

- Make sure all parts are correctly connected and tighten all bolts using screwdriver .
- Tapping in the wooden caps (F) to cover bolts head using rubber mallet.

CONGRATULATION !

THE BENCH IS NOW READY FOR USE.