

ASSEMBLY INSTRUCTIONS



LIST OF WOODEN PARTS

NO.	DESCRIPTION	Q'TY
A1	RIGHT SIDE FRAME	1 PC
A2	LEFT SIDE FRAME	1 PC
B	BACK SUPPORT	1 PC
C	SEAT	1 PC
D1	FRONT APRON	1 PC
D2	BACK APRON	1 PC

QUESTION ?

Identify all parts and hardware. If any pieces are missing call our toll free number at 1-888-287-4275 from 9:00 am to 5.00 pm CST (Monday to Friday) for replacement parts. For faster service, have the style number handy when calling.

LIST OF HARDWARE PARTS :

- E**  1 1/2" BOLT 6 PCS + 1
- F**  1" SCREW 4 PCS + 1
- G**  WOODEN CAP 6 PCS + 1

- NOTE :** 1. PLEASE READ THE INSTRUCTION SHEET CAREFULLY BEFORE YOU START ASSEMBLY.
 2. PLEASE DO NOT TIGHTEN THE BOLTS UNTIL ALL BOLTS ARE IN THE CORRECT POSITION AS SHOWN IN THE DIAGRAM.
 3. PHILLIP'S SCREWDRIVER IS NEEDED IN ASSEMBLING (NOT PROVIDED).

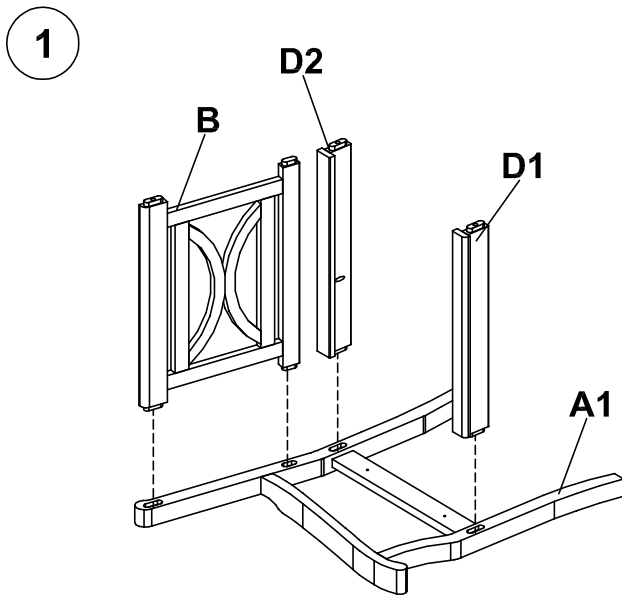

- Attach the back support (B) and apron (D1 & D2) into right side frame (A1).

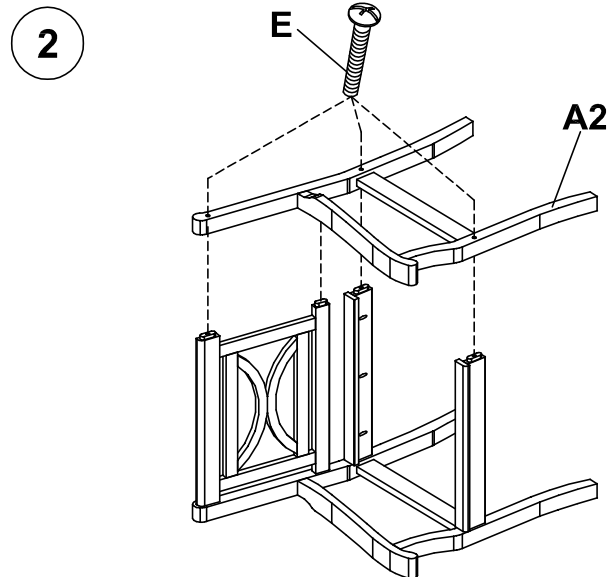

- Attach the left side frame (A2) into back support (B) and apron (D1 & D2).
 - Insert bolts into predrilled holes and secure using 1 1/2" bolt (E).

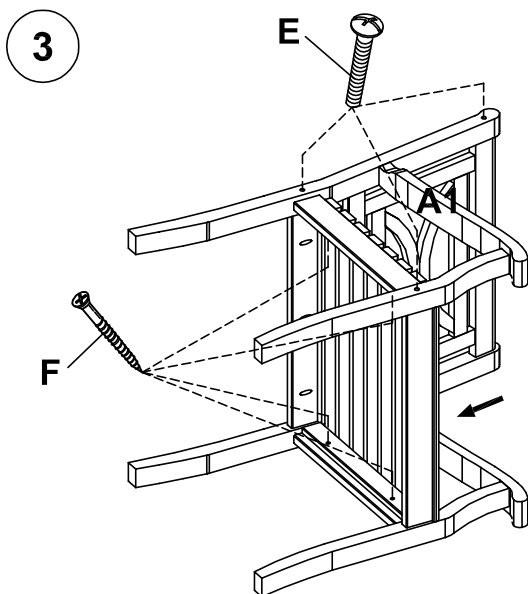

- Upside the chair.
 and repeat step 2 procedure to secure the right side frame (A1).
 - Secure using 1" screw (F) to seat (C).
 - Tighten all bolts completely using screwdriver.

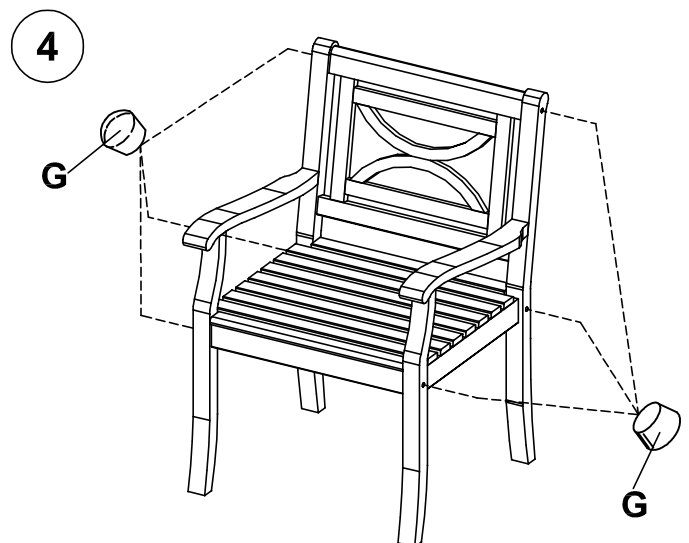

- Make sure all parts are correctly completed and tighten all bolts completely using screwdriver.
 - Tapping in the wooden cap (G) to cover bolts head using rubber mallet.

THE CHAIR IS NOW READY FOR USE.

IT- 120898T