

ASSEMBLY INSTRUCTIONS

LIST OF WOODEN PARTS

NO.	DESCRIPTION	Q'TY
A	TABLE TOP	1 PCS
B	SHELF	1 PCS
C	LEG	4 PCS

QUESTION ?

Identify all parts and hardware. If any pieces are missing call our toll free number at 1-888-287-4275 from 9:00 am to 5:00 pm CST (Monday to Friday) for replacement parts. For faster service, have the style number handy when calling.

LIST OF HARDWARE PARTS :



NUT 4 PCS + 1



SPRING WASHER 4 PCS + 1



WASHER 4 PCS + 1



1" SCRW..... 4 PCS + 1



WRENCH 1 PCS

NOTE : 1. PLEASE READ THE INSTRUCTION SHEET CAREFULLY BEFORE YOU START ASSEMBLY.

2. PLEASE DO NOT TIGHTEN THE BOLTS UNTIL ALL BOLTS ARE IN THE CORRECT POSITION AS SHOWN IN THE DIAGRAM.

3. PHILLIP'S SCREWDRIVER IS NEEDED IN ASSEMBLING (NOT PROVIDED).

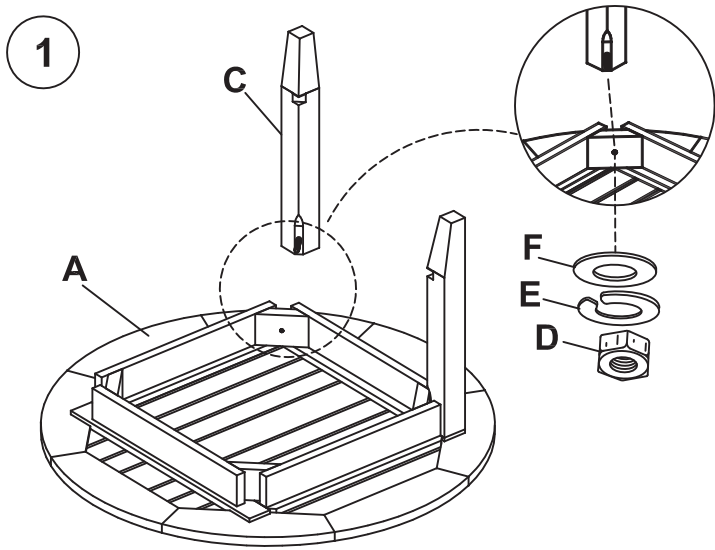

- ATTACH LEG (C) INTO CORNER OF TABLE TOP (A). INSERT WASHERS, SPRING WASHERS AND NUTS TO SECURE LEG (C).
- TIGHTEN NUT USING WRENCH, PROVIDED.

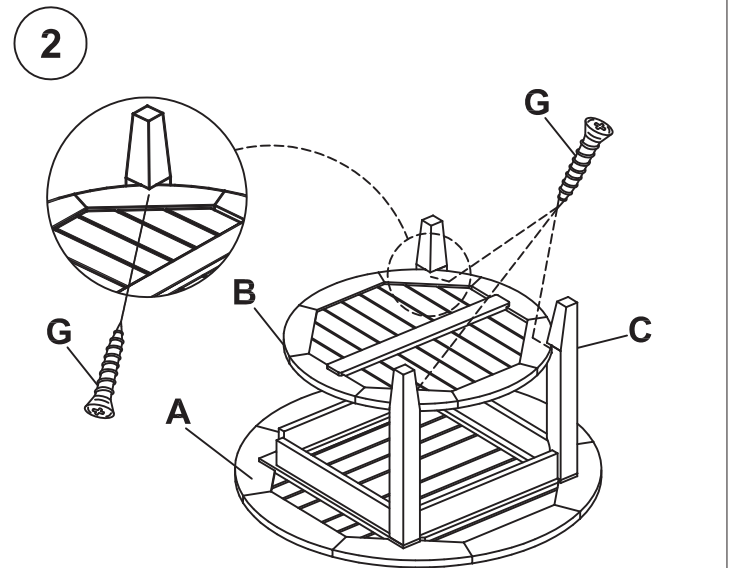

- ATTACH THE SHELF (B) TO LEG HOLES (C) AND SECURE 1" SCREWS FROM SHELF (B) TO LEGS (C).

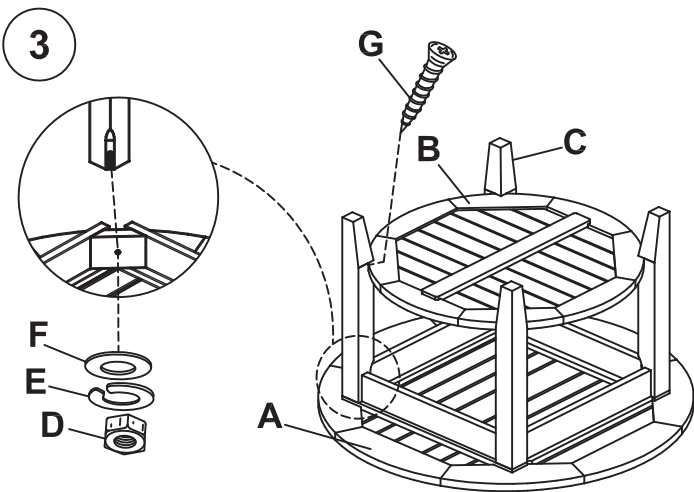

- ATTACH LEG (C) INTO CORNER OF TABLE TOP (A) AND TO SHELF (B). INSERT WASHERS, SPRING WASHERS AND NUTS TO SECURE LEG (C).
- TIGHTEN NUT USING WRENCH, PROVIDED.
- INSERT 1" SCREW TO SHELF (B) TO LEG (C). TIGHTEN ALL SCREWS USING SCREWDRIVER.

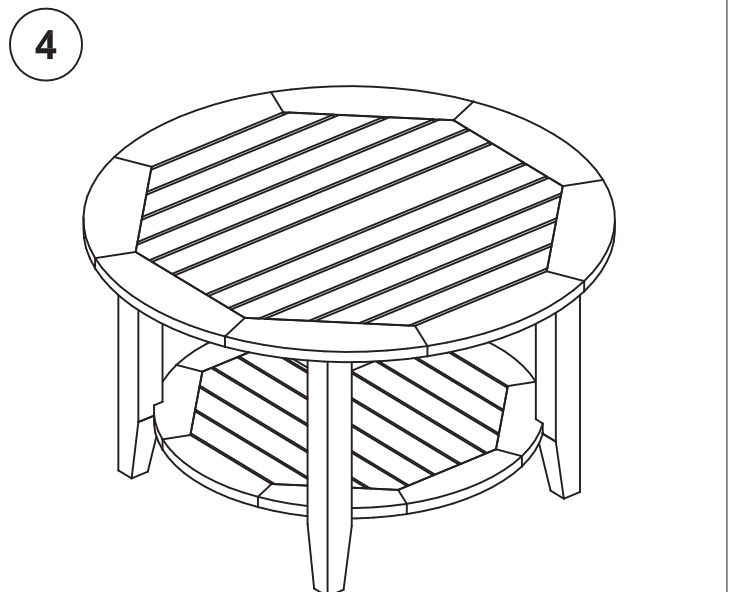

CONGRATULATIONS !
THE TABLE IS NOW READY FOR USE.