

Welcome!

We greatly appreciate your purchase of the PNP400 series Pop 'N Plug Tower. We are sure you will find it reliable and simple to use. Superior performance for the right price, backed by solid technical and customer support is what ALTINEX has to offer.

We are committed to providing our customers with Signal Management Solutions[®] to the most demanding audiovisual installations at competitive pricing and we welcome you to join the ranks of our many satisfied customers throughout the world.

1. Precautions and Safety Warnings

Please read this manual carefully before using your PNP400/PNP408 and keep it handy for future reference. These safety instructions are to ensure the long life of your PNP400/PNP408 and to prevent fire and shock hazards. Please read them carefully and heed all warnings.

1.1 General

- There are no user serviceable parts inside. Qualified ALTINEX service personnel must perform all service on the PNP400/PNP408.

1.2 Installation Precautions

- Place the PNP400/PNP408 on a flat, leveled surface in a dry area away from dust and moisture.
- To prevent fire or shock, do not expose this unit to water or moisture. Do not place in direct sunlight, near heaters, or heat-radiating appliances, or near any liquid.
- Handle the PNP carefully. Dropping or jarring can cause damage.
- Do not pull any cables that are attached to the PNP400/PNP408.
- Do not place heavy objects on top of the PNP400/PNP408.

2. Installation Procedures

- Step 1. Refer to the ALTINEX website, www.altinex.com, to download the latest templates and instructions for tabletop cutting requirements and installation. Search for the PNP400/PNP408 and go to its detail page. The links to the templates, user's guide, and more are on the left-hand side of the screen. The table can be 0.25-4.0 in (6-102 mm) thick.
- Step 2. Print all installation information for the PNP400, including the templates and any detailed instructions.
- Step 3. Mark the table's surface to indicate the correct positioning of the unit. The face of the unit is typically parallel to the longest sides of the tables.
- Step 4. Cut an opening into the table's surface. This operation should be performed by experienced professionals in order to insure accuracy and to be aesthetically pleasing. Always confirm dimensions before cutting to insure that specifications have not changed.
- Step 5. Lower the PNP400/PNP408 into the opening in the table and make sure the bezel of the unit sits evenly in the table.
- Step 6. From under the table, insert the mounting brackets into the slots on the side of the unit. See Diagram 6 of the online manual for details. Place the brackets (one on each side) at the desired height for the table thickness and secure them to the bottom of the table using the thumb screws provided.
- Step 7. Secure the power cord using the cable clamp provided. Pass the power cord (if any) from the bottom of the housing and attach it to the table leaving a service loop beneath the unit. Before tightening the clamp, open and close the unit from the top several times. Set the service loop for smooth operation only. Do not leave excessive cable hanging below the table.
- Step 8. Secure PNP400/PNP408 signal cables separate from the power cord. All cables should have a service loop to allow the unit to open and close easily.
- Step 9. Once you have connected power and the proper cables to the unit, you may raise the unit into position by pressing the top of the unit.
- Step 10. To lower the unit, push on the top of the unit until it locks into place. Do not use excessive force to press down on the pop-up

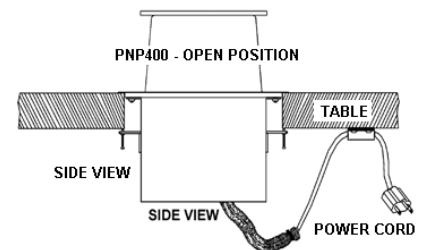

3. Limited Warranty/Return Policies

Please see the ALTINEX website at www.altinex.com for details on warranty and return policies.

4. Technical Specifications

Specifications are subject to change. See www.altinex.com for up-to-date information.

Features/Description	PNP
PNP400*	
Pass-Through AC Power	9-10 ft (2.7-3.0 m)
110 VAC, 60 Hz, 5 A	NEMA F-M
Number of slots	6 (each side)
Compatibility*	
AC Power (United States)	SP2102US, SP2107US
AC Power (International)	SP2201UK, SP2301CE
Audio, Video, and Control	SP3201AV, SP3210AV, SP1100SC, and SP3502SC
Blank Slot Covers	SP1001BL, and SP1002BL
Customizable	SP3102EP, SP3103EP
PNP408*	
Audio, Video, Communication	6 ft (2 m)
Computer Video	15-pin HD F-M (2)
Computer Audio	3.5mm F-M (2)
HDMI	HDMI F-M (2)
Network	CAT-6 (RJ-45) F-M (4)
USB	Type A F-M (4)
Pass-Through AC Power	9-10 ft (2.7-3.0 m)
110 VAC, 60 Hz, 5 A	NEMA F-M
PNP400/ PNP408 Models*	
Accessories Included	
Hardware	Mounting screws/brackets Cable clamps/screws Fastener Tool

Table 1. PNP400/PNP408 General

* Includes models ending in S (brushed aluminum).
Models ending in C are customizable.

Mechanical	PNP400 / 408**
Max. Table Thickness	4.00 in (102 mm)
Min. Table Thickness	0.25 in (6 mm)
Height Above Table (open)	2.909 in (74 mm)
Height Below Table Surface	5.760 in (146 mm)
Base Width	6.674 in (170 mm)
Base Depth	4.840 in (123 mm)
Finish PNP400,PNP408: PNP400S,PNP408S:	Matte Black Brushed Aluminum
Weight (approx.) PNP400* PNP408*	4.95 lb. (2.25 kg) 8.30 lb. (3.76 kg)
Shipping Weight	
T° Operating	10°C-35°C
T° Maximum	50°C
Humidity	90% non-condensing

Table 2. PNP400/PNP408 Mechanical**

Electrical (Single outlet panel)	PNP400 / PNP408 **
Power Rating (pass-through AC power)	110 VAC, 60 Hz, 5 A

Table 3. PNP400/PNP408 Electrical **

** Dimensions and ratings include models ending in C and S.

5. About Your PNP400

- Dual side connectivity
- Gas spring for smooth operation
- Simple, drop-in installation
- Standard high-quality matte black or brushed aluminum finish
PNP400/PNP408: Matte Black PNP400S/PNP408S: Brushed Aluminum
- Customizable connectors

The PNP400/PNP408 Interconnect Tabletop Solution is designed for installation into a conference room table. The PNP400/PNP408 provides a means of connecting audiovisual, network, and power sources into a presentation system. The PNP400/PNP408 can "pop up" into a raised position to provide access to connectors, or it can be lowered into a table when not in use. The PNP400/PNP408 uses a tower-type construction with a gas spring to raise the interface into position above the tabletop.

The PNP400 Interconnect has two openings on either side of the unit for 6 single-slot sectional panels, servicing both sides of a table. Available plates include combinations of audio, analog and digital video, network, USB and AC power connectors, providing extensive flexibility in a convenient package. These sectional plates are easy to install in the field, or can be custom pre-configured at ALTINEX to arrive in a ready-to-go package.

The PNP408 is a "package" that covers the basic needs of many users and ships complete with 2 standard U.S. power receptacles, computer video (15-pin HD) audio (3.5 mm), standard HDMI, 2 network (RJ-45), and 2 USB (Type A) input connectors on each size of unit. All audiovisual connectors have 6 ft. (2 m) cables that feed through to the bottom of the unit.



PNP400

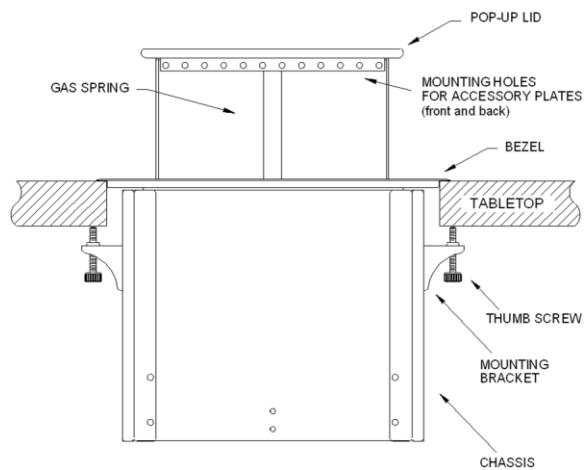

PNP408

- USB F (x4)
- RJ4 F Network (x4)
- HDMI F (x2)
- 15-pin HD F VGA (x2)
- AC Power (x4)

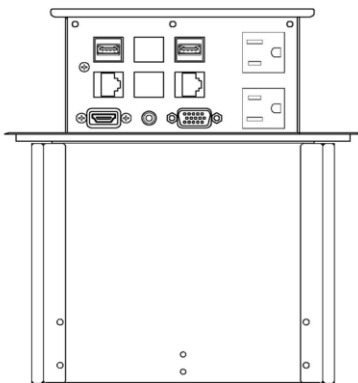

Front view

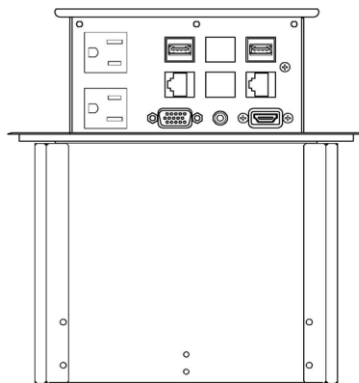

Back view

6. Application Diagrams

Diagram 1: Typical Setup

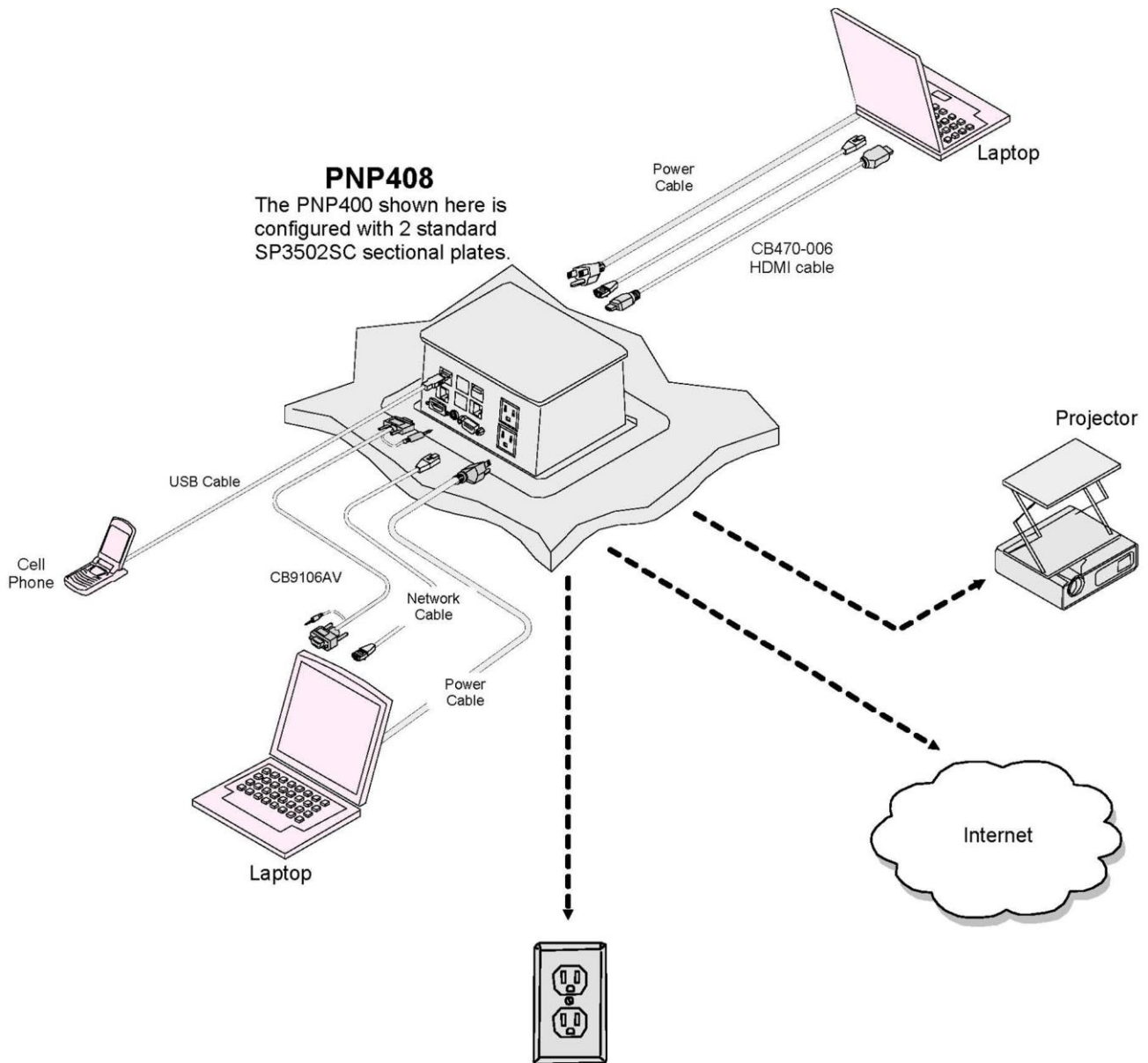

Diagram 2: Cutout (Reference not set to scale 1:1)

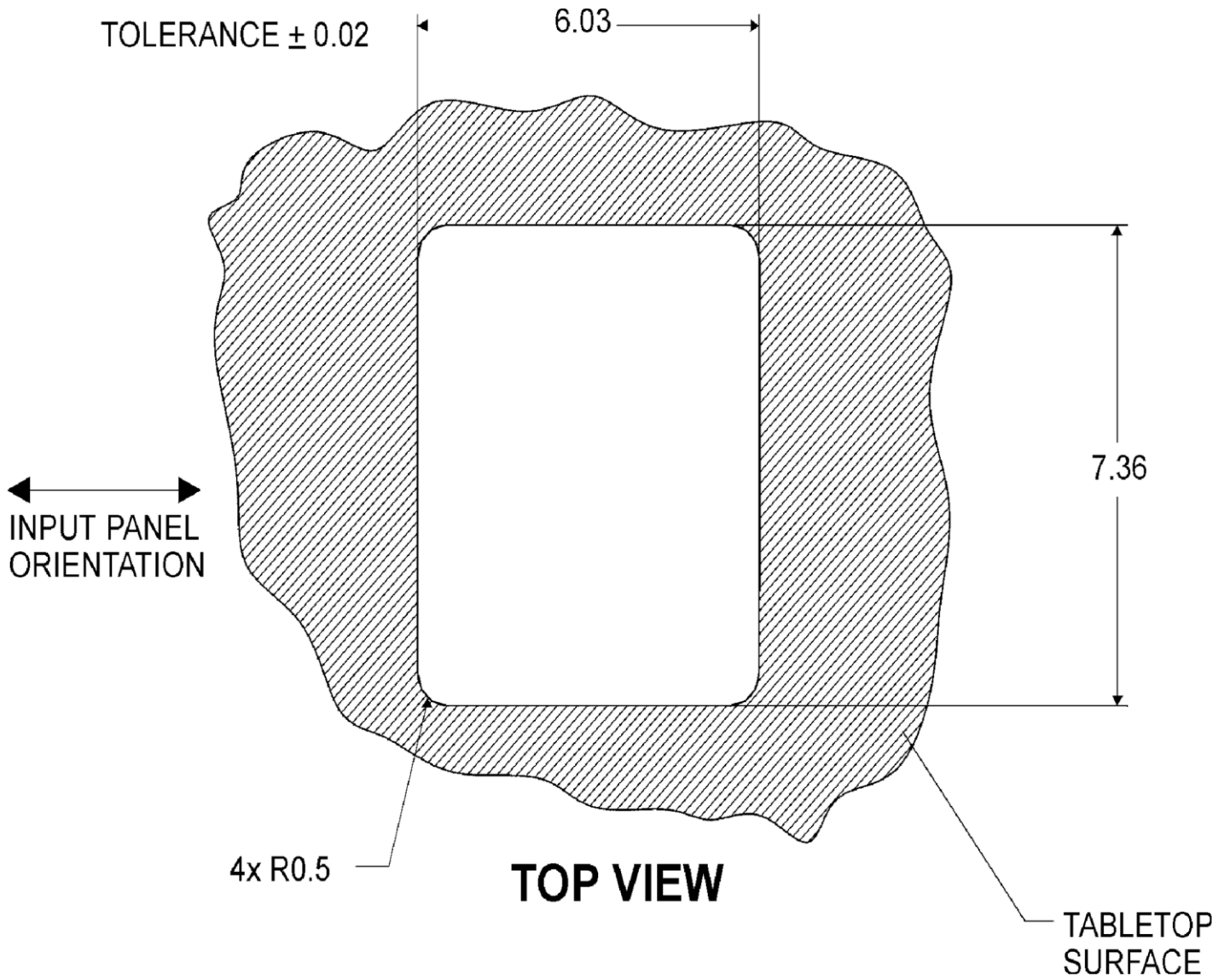

Diagram 3: Top View

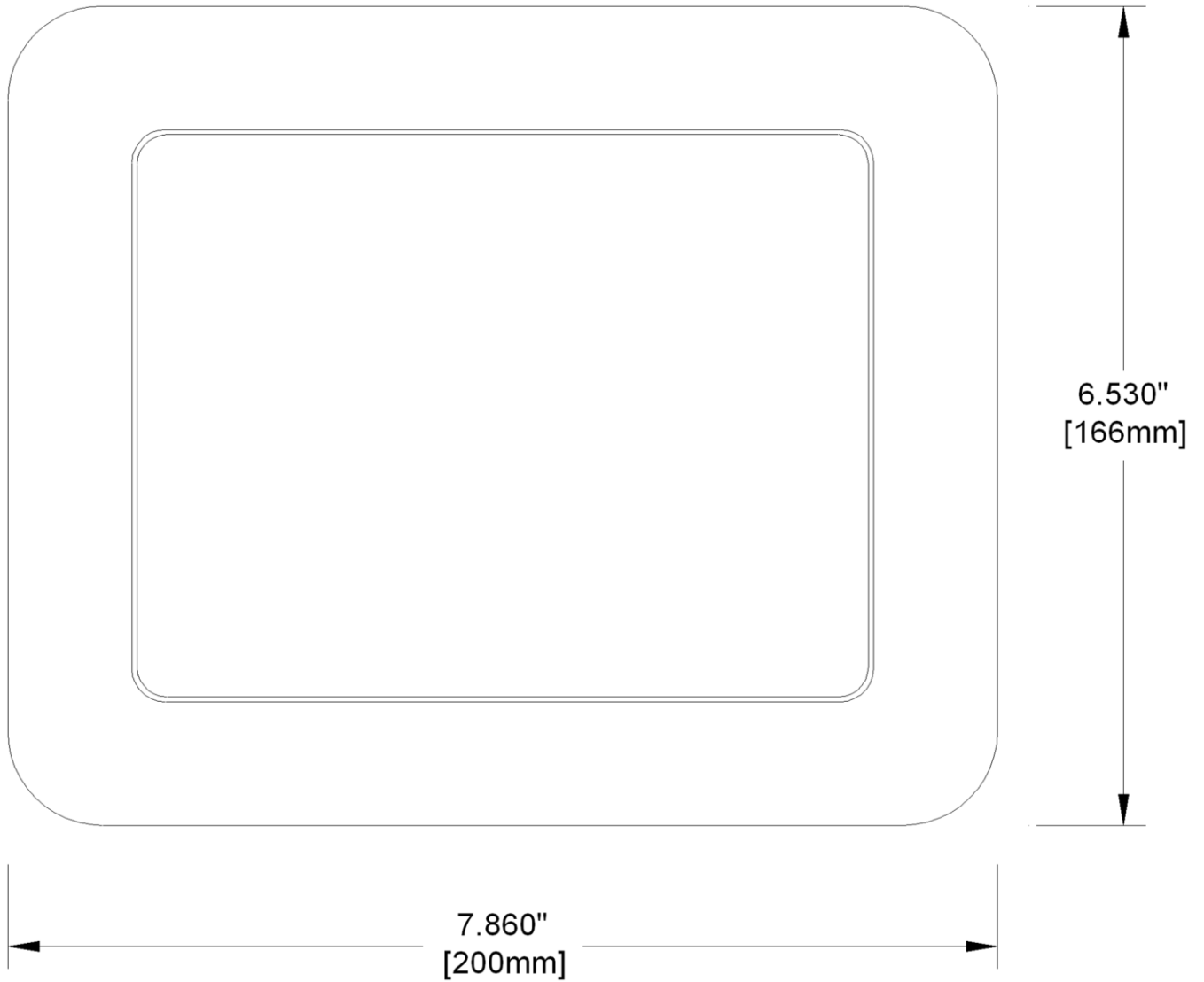

Diagram 4: Front View

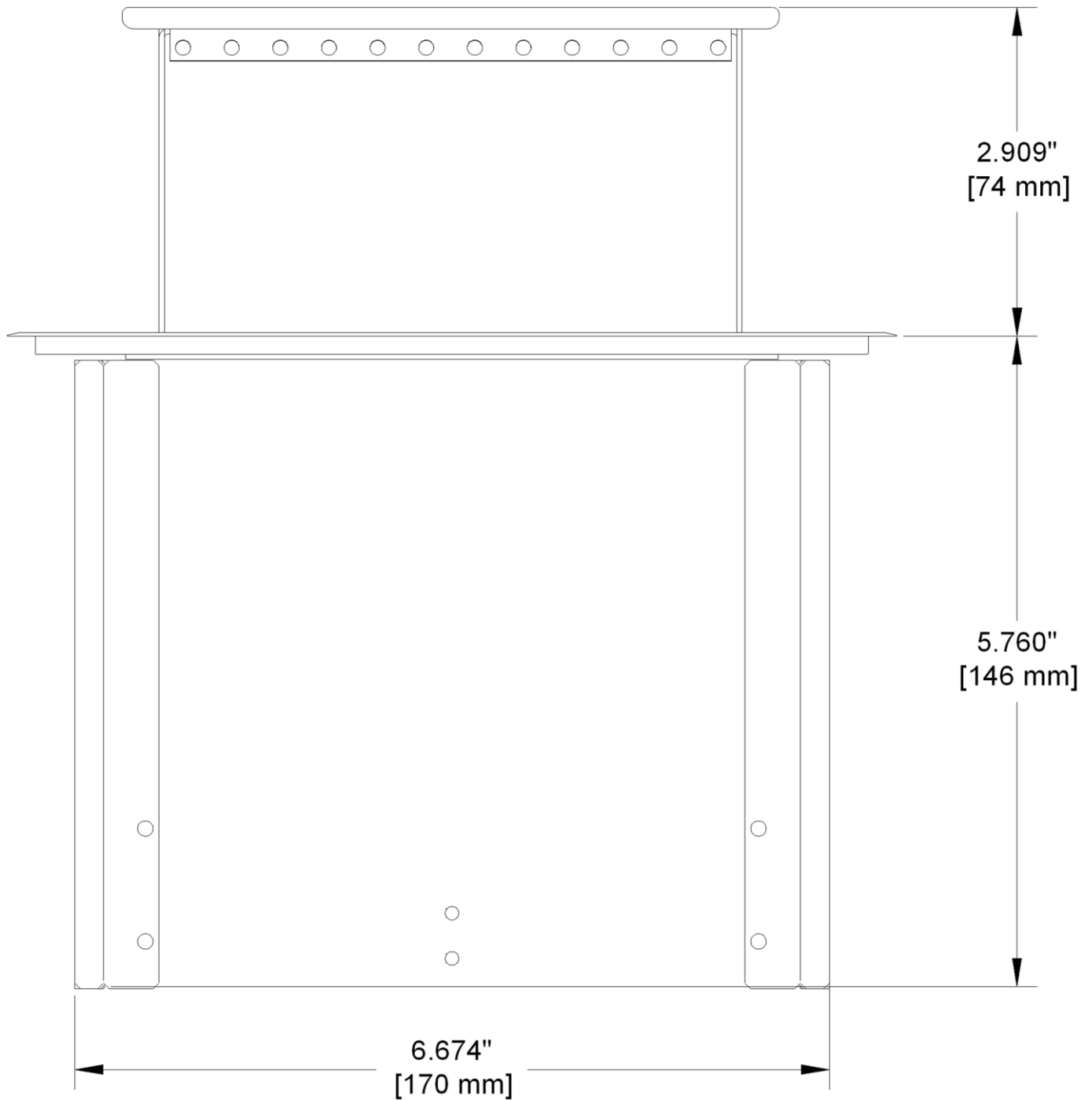

Diagram 5: Side View

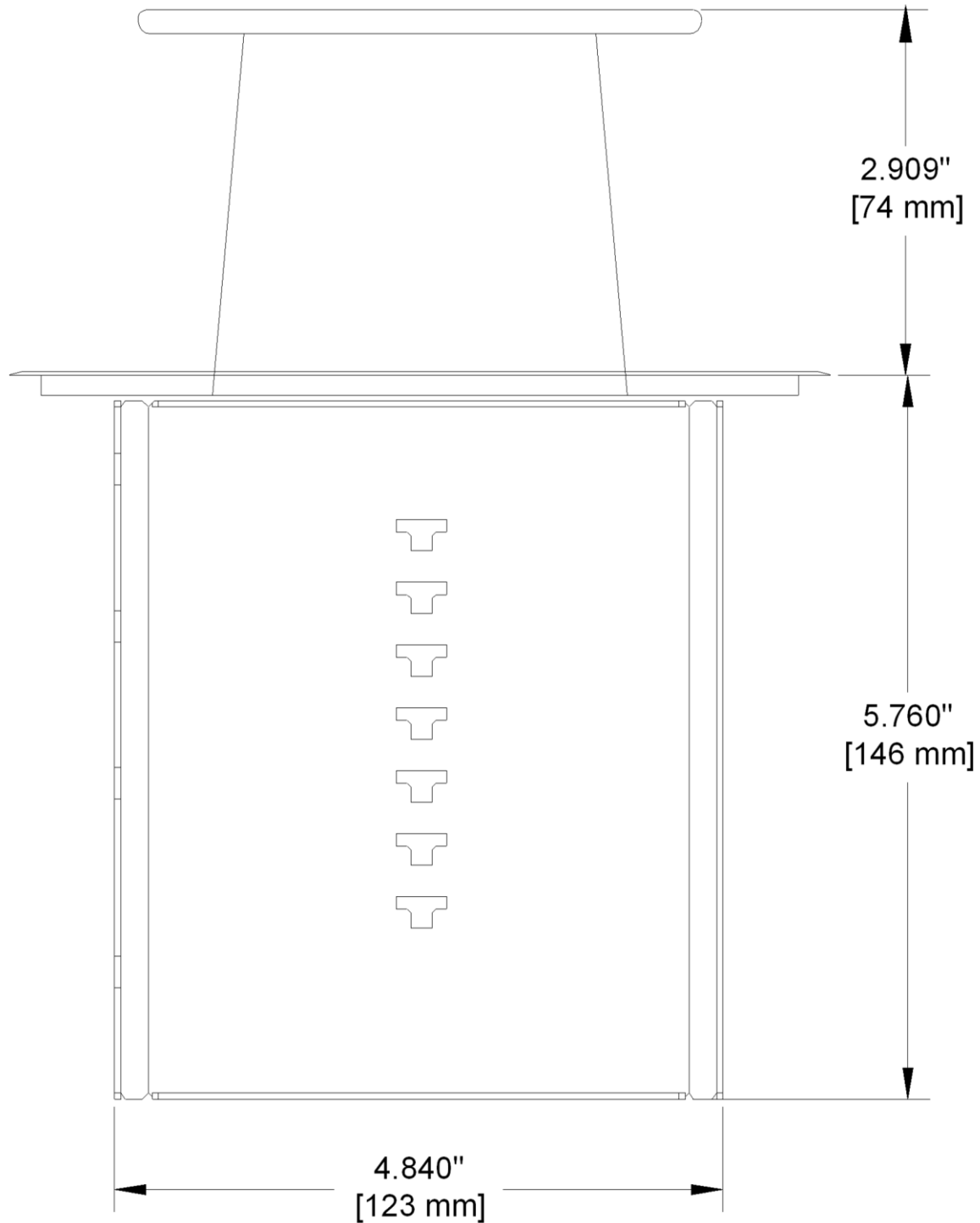

Diagram 6: Mounting

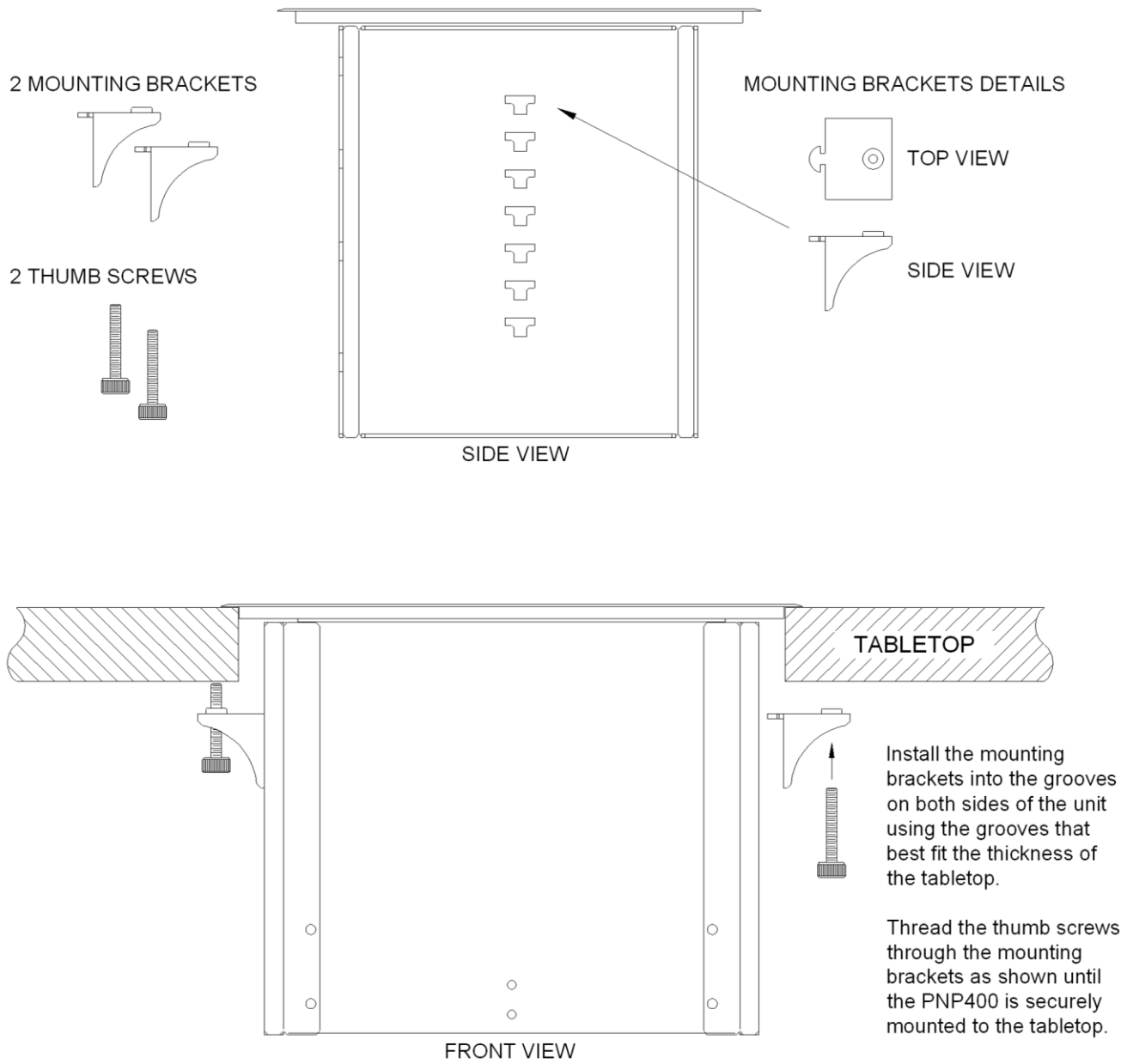
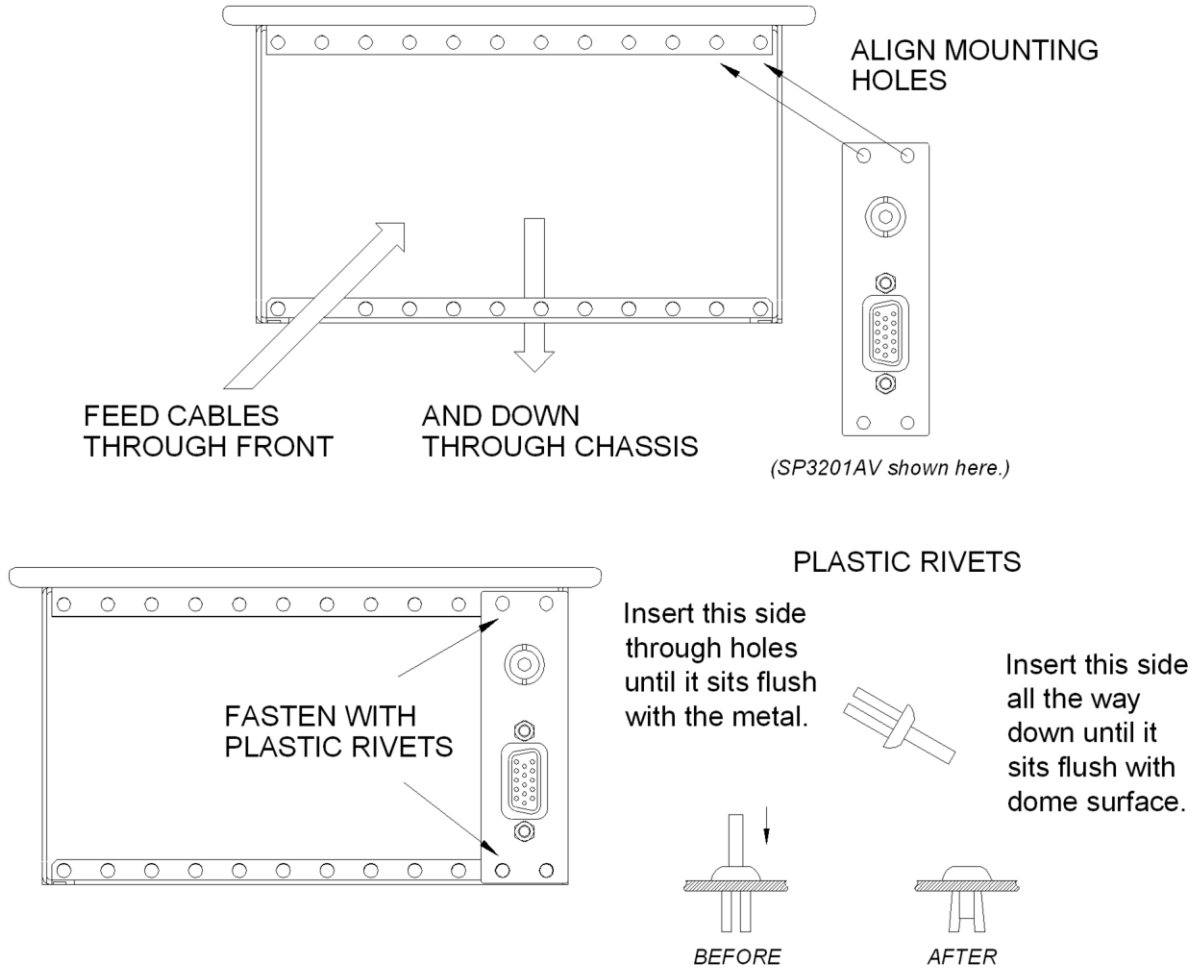

Diagram 7: Accessory Installation



- 1 Feed any cables attached to the sectional plate through the front of the PNP400, then down through the opening in the bottom of the chassis. Make sure the cables exit the chassis on the same side as the plate. They should NOT cross over the center of the unit.
- 2 Align the mounting holes of the sectional plate and PNP400 chassis.
- 3 Use the plastic rivets supplied with the sectional plate to fasten the sectional plate to the chassis. A rivet tool is supplied with the PNP400.

NOTE: The plastic rivets may be removed by pressing the center pin all the way through the material using a small screwdriver. Then use small pliers to remove the plastic, being careful not to scratch the metal.

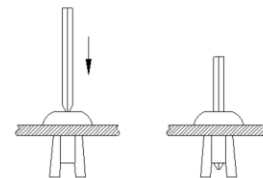

Diagram 8: Cables/Accessories

Model No.	Description
SP1001BL	Blank cover Plate 1 slot
SP1002BL	Blank cover Plate 2 slots
SP2102US	Dual AC Power Outlet for United States & Canada with 2 slots
SP2107US	Dual AC Power Outlet for United States & Canada with 2 slots and 12 ft (4 m) metal conduit
SP2201UK	AC Power Outlet for United Kingdom, Singapore & HK 3 slots
SP2301CE	AC Power Outlet for Continental Europe 3 slots
SP3102EP	Dual, Empty Snap-in Ports with 1 slot
SP3103EP	Dual, Empty Ortronics CAT-6 Snap-in Ports with 1 slot
SP3201AV	15-pin HD-Female to Male+ 3.5 mm Stereo Female to Male 1 slot
SP3210AV	HDMI Female to Male 1 slot
SP1100SC	EMPTY STANDARD CONFIGURATION 6 slots
SP3502SC	STANDARD CONFIGURATION PLATE 6 slots 1X VGA, 1X HDMI, 1X 3.5MM AUDIO, 2X USB, 2X CAT5E
Replacement Parts	
AC401-303	Gas Spring for PNP400 Series

7. Operation

7.1 Install Sectional Plates

Install sectional plates in the empty slots on each side of the PNP400 until the plates snap into place. Secure the plates using the plastic, removable rivets as shown in Diagram 7.

8. Troubleshooting Guide

We have carefully tested and found no problems in the supplied PNP400; however, we would like to offer suggestions for the following:

- Please make sure that the highest quality video, audio, network, and telephone cables or connectors are used.
- If there has been damage, then do not use the PNP400 unit. Immediately contact the ALTINEX Sales Department to have the unit repaired.