



Scan for full manual

TBUS-204 Quick Start Guide

This guide helps you install and use your **TBUS-204** for the first time.

Go to www.kramerav.com/manual/TBUS-204 to download the latest user manual

Step 1: Check what's in the box

- ✓ **TBUS-204** Pop-up Table Connection Bus
- ✓ 1 Clamps set
- ✓ 1 User manual
- ✓ 1 Quick start guide
- ✓ 1 Metal cut-out template

Step 2: Get to know your TBUS-204

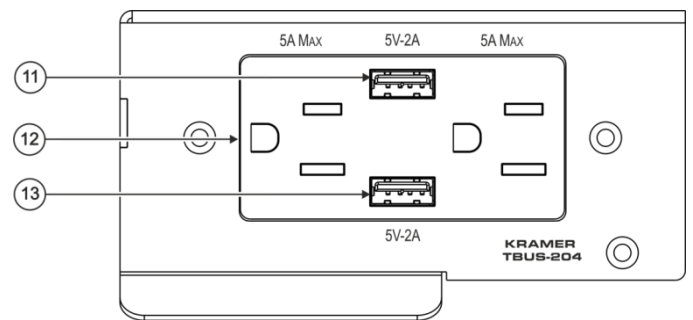
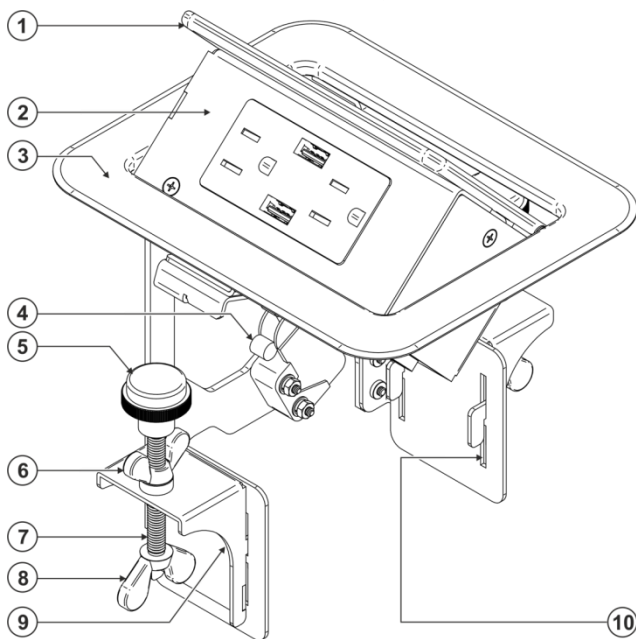

#	Feature	Function
1	Pop-up Lid	Covers the connecting surface, leaving the table surface neat and tidy.
2	Connecting Surface	See following graphic.
3	Outer Rim	Fits over the table surface.
4	Mini Latch	Enables closing and opening the lid by applying slight pressure.
5	Rubber Protectors (x2)	Ensures gentle tightening to the table's underside.
6	Locking Butterfly Nuts (x2)	Tighten to lock the mounting screws.
7	Mounting Screws (x2)	For securing the TBUS-204 to the table.
8	Mounting Butterfly Nuts (x2)	Tighten to secure the unit to the table's surface.
9	Mounting Clamps (x2 units)	Place in the clamp slits after inserting the enclosure into the table – for securing the unit to the table surface.
10	Mounting Clamp Slits (two sets on each side)	Insert the mounting clamps to the slits when installing the TBUS-204 .
11	5V-2A USB Charging Port	Use to charge a device.
12	5A/125V Power Connector (x2)	Connect to a US power consuming device.
13	5V-2A USB Charging Port	Use to charge a device.

Step 3: Install the TBUS-204

A: Cut an opening in the table using the metal cut-out template. Before cutting check the latest cut-out dimensions from the Kramer website at www.kramerav.com/downloads/TBUS-204:

- Place the cut-out template on the surface of the table exactly where you want to install the **TBUS-204**.
- Attach the cut-out template to the table with the included screws.
- Following the **inside** edge of the template, cut a hole in the table surface with a sabre or keyhole saw according to the dimensions.
- Unscrew and remove the template from the surface of the table and clean the table surface.
Take care not to damage the table. If needed, you can download a full-scale template from the Kramer website at www.kramerav.com/downloads/TBUS-204.



Take care not to damage the table. Kramer Electronics is not responsible for any damage caused to the table.

B: Insert **TBUS-204** into the cut-out opening:

- Carefully insert the unit into the prepared opening.
- Under the table, insert the mounting clamps into the mounting clamp slits at the desired height (on both the front and rear sides of the unit).
- Make sure that the upper outer rim is situated parallel to the edge of the table.
- Insert the mounting screws through the holes in the mounting clamps. Tighten the mounting butterfly nuts to secure the unit to the table surface and then lock with the mounting butterfly screws.

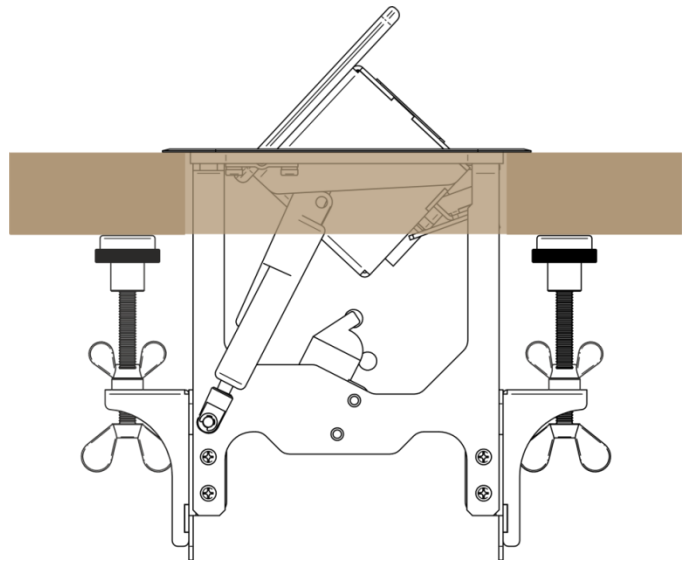

C: Connect the power cable from underneath the **TBUS-204** and then power or charge devices as required.

