

Ordering Information



Description	Finish	Color/Material	Surface Mount	Flush Mount
15A 125V Tamper-Resistant Pop-Up Kitchen Counter Receptacle, Rated for 20A circuits	Powder Coated	Black White	RCT200BK RCT200W	RCT201BK RCT201W
	Brushed	Aluminum Brass Nickel	RCT200ALU RCT200BR RCT200NI	RCT201ALU RCT201BR RCT201NI
	Polished	Chrome	RCT200CH	RCT201CH
	Matte	Bronze	RCT200BZE	RCT201BZE



Specifications

Performance

Configuration	15 amp 125 volt, Tamper Resistant Receptacle
Circuit Rating	20 amp non-feed through
Listings	cULus Listed to UL498, Section 145 Mechanical Load Test, 146 Spill Test
Dielectric Voltage	Withstands 2,000V minimum
Terminal Accommodation	#14-#12 AWG copper stranded or solid conductor only
Terminal Identification	Terminals identified in accordance with UL 498 and CSA
Flammability	UL 94V-2
Operating Temperature	Maximum continuous 75°C, minimum -40°C (w/o impact)

Materials

Cover and Flange	Die Cast Aluminum
Main Body	Engineered Thermoplastic PBT
Wiring Chamber	Die Cast Aluminum
Water Seals	Elastomers and Silicon

Dimensions Inches (mm)

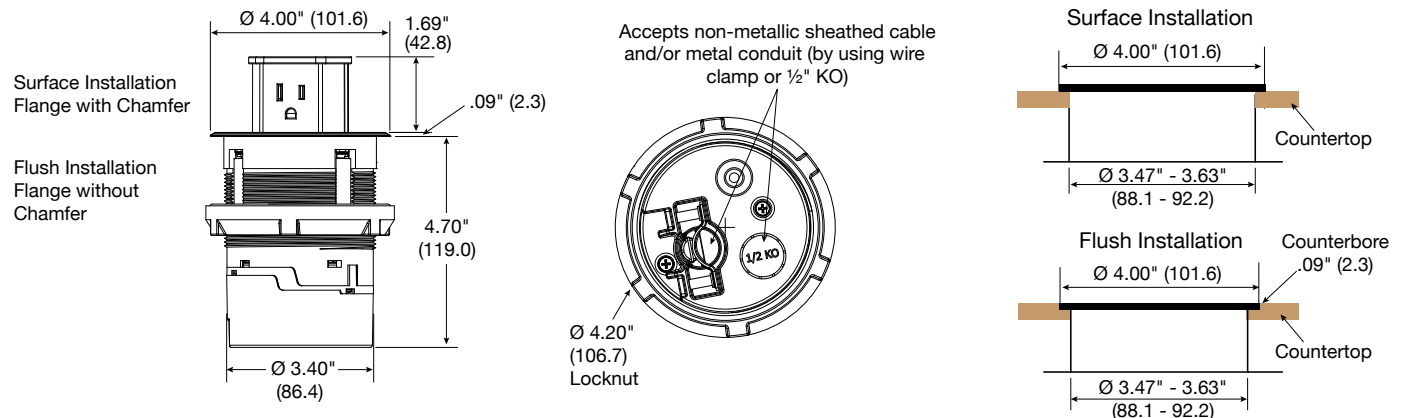

Note: Recommended to be fed by a GFCI circuit, up to 20 Amp Service.