

# ***KOBELT***

DISC BRAKES  
HYDRAULIC STEERING & ACCESSORIES  
ELECTRONIC CONTROLS  
PNEUMATIC CONTROLS  
PUSH-PULL CONTROLS

FOR THE LATEST INFORMATION  
PLEASE VISIT [www.KOBELT.com](http://www.KOBELT.com)

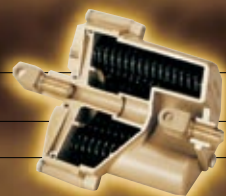

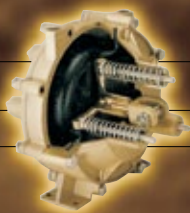

# When Reliability is Everything.

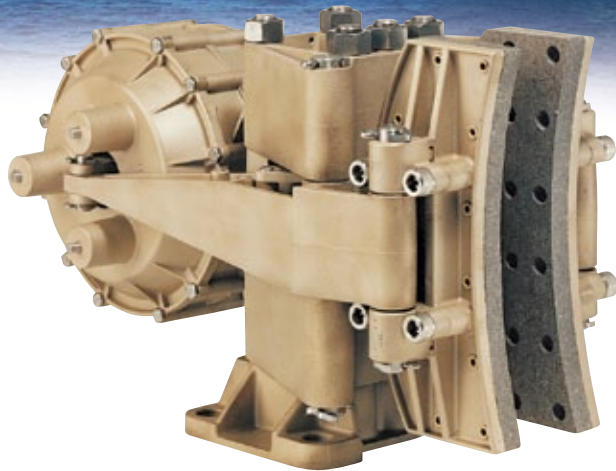

*K*obelt has gained worldwide recognition for manufacturing extremely reliable controls and disc brake systems. And we're put to the test every day. Kobelt Manufacturing has been producing high quality marine controls, steering components and brake systems for 50 years. Contact us today!

***KOBELT*** *Quality Control*



# KOBELT DISC BRAKES

## GENERAL INFORMATION

Kobel Manufacturing has been designing and manufacturing disc brake systems for 50 years. We have gained an enviable reputation for cost-effective performance and reliability.

Kobel disc brakes are used in all corners of the world. The applications we serve are limitless. Sales and service are available from distributors throughout the world.

Most of our older brake calipers were manufactured in sand cast bronze. Increased demand prompted us to apply our extensive knowledge of bronze die-casting technology to a whole new series of brakes. Caliper models 5019-5030 are made entirely of die-cast silicon bronze with stainless steel hardware. While older models are still available upon special request, the new series is much more uniform in design and is also more cost-effective.

All our calipers are available in either fluid or spring applied configurations. Several types of brake linings are also available to conform with environmental guidelines.

## APPLICATIONS

- Aerospace
- Cable spooling reels
- Cable trams
- Chair lifts
- Conveyor belt systems
- Draw works disc brakes, both on land and off-shore
- Drill ship anchor handling
- Hoists
- Industrial equipment
- Logging and forestry
- Mining
- Paper industry
- Pipe laying barges
- Propellor shaft brakes, from 40 - 50,000 H.P.
- Railroad equipment
- Sugar industry
- Wind generators

## DISC BRAKE SELECTION

Selecting the proper brake disc and brake caliper is important and can only be accomplished if all the information pertaining to the operation of the braking system is made available to Kobelt Manufacturing.

When completing the application form, it is best to consider the most challenging operating conditions. If a brake runs 95% of the time on the light-duty cycle, and 5% on the heavy-duty cycle, it is the 5% that must be considered when selecting a braking system.

Disc brakes are used in innumerable types of applications. A static holding brake obviously requires very little consideration. Stopping brakes are relatively simple. Tensioning and cycling brakes can become very complex. We have in-house computer programs to assist our customers in selecting the proper combination of brake disc and brake caliper.

The information that we provide is reliable within 5%, and includes a 20% safety margin. If a brake disc, however, is poorly installed, no air circulation, overheating, disc failure and premature lining wear may result.

When installing a brake disc that is running at elevated temperatures, it is of extreme importance to allow for disc expansion and contraction in operation. Bolt holes for attaching a disc should be over-sized and spigot IDs must have clearance. Failing to leave allowance for disc expansion and contraction may result in early disc failure.

Contact Kobelt Manufacturing with the details of your specific application. Let us help you select the most suitable disc brake system to stop your machinery safely and effectively.



Kobel is ISO 9001:2000 certified.

# GENERAL INFORMATION

A brake disc must have the ability to absorb and radiate the energy that is imposed on it without over heating. The brake caliper must also have sufficient lining area to absorb the energy without going beyond the Pressure Velocity Ratio. The PV ratio should never exceed 250,000; that is to say, pounds per square inch of lining pressure and feet per minute rubbing speed. No general rule can be given in this area since all the factors of a braking system must be considered before making a definite choice. Small brake shoes such as the 5019 and 5020 are not suited for continuous energy input unless, of course, the energy is very small. The table below shows the horsepower hour (H.P. hour) before brake lining replacement becomes necessary. In other words, a 5020 brake caliper

can absorb 1733 H.P. hour before brake lining replacement becomes necessary. If, however, the temperature exceeds 650°-700° F, the lining will disappear at a much faster rate. Looking at brake caliper 5026, you will note that 27,160 H.P. hour of energy input into the lining is available. Again, if elevated temperatures occur, lining wear will accelerate. It is, therefore, extremely important to first of all pick a disc that is capable of absorbing the energy, and a brake caliper having sufficient lining to give a reasonable service life for the brake lining.

The disc thickness is also specified in the table below, as well as the minimum lining thickness before lining replacement should take place.

CALIPER	5019		5020		5021		5022		5023		5024		5025		5026		5027		5028	
	-A	-S	-A	-S	-A	-S	-A	-S	-A	-S	-A	-S	-A	-S	-A	-S	-A	-S	-A	-S
Weight (lbs.)	15	17	36	42	53	59	92	102	52	61	97	108	104	113	177	186	165	186	330	349
Maximum Clamp Force (lbs.)	5,250		9,160		9,160		18,320		16,000		25,740		17,160		32,000		48,000		48,000	
Lever Ratio	3.5:1		3.8:1		3.8:1		3.8:1		4.12:1		4.29:1		4.29:1		4.0:1		4.0:1		4.0:1	
Actual Force each side (lbs. per actuator)	750		1,200		1,200		1,200		2,000		3,000		2,000		2,000		3,000		3,000	
Number of Levers	2		2		2		4		2		2		2		4		4		4	
Total Shoe Area (in. <sup>2</sup> )	18		26		60		86		60		75		120		194		114		420	
Lining Thickness (in.)	.3125		.375		.50		.50		.50		.625		.625		.625		.625		.70	
Maximum Allowance Lining Wear (in.)	.140		.200		.300		.300		.300		.420		.420		.420		.420		.500	
H.P. Hour	840		1,733		6,000		8,600		6,000		10,500		16,800		27,160		15,900		69,000	
Disc Maximum Thickness (in.)	3/4		1 1/4		2		2		2		2		4		4		2		4	
Disc Diameter (in.)	9-20		12-30		18-60		18-60		18-60		18-60		24-72		30-72		30-72		42.5-96	
Disc Rubbing Face Width (in.)	2		2 1/2		4		4		4		4		7		7		4		10	
Pipe Fitting <i>Fluid Applied</i> NPT	1 of 1/4"		2 of 1/4"		2 of 1/4"		4 of 1/4"		2 of 1/4"		2 of 1/4"		2 of 1/4"		4 of 1/4"		4 of 1/4"		4 of 1/4"	
Volume (In <sup>3</sup> ) <i>Maximum Fluid Applied</i>	9		30		30		60		55		90		55		110		180		180	
Pipe Fitting <i>Spring Applied</i> NPT	1 of 1/4"		1 of 1/4"		1 of 1/4"		2 of 1/4"		1 of 3/8"		1 of 3/8"		1 of 3/8"		2 of 3/8"		2 of 3/8"		2 of 3/8"	
Volume (In <sup>3</sup> ) <i>Maximum Spring Applied</i>	9		19		19		38		48		48		48		96		96		96	

## CUSTOM ACTUATORS

Kobel Manufacturing offers many actuators that can be fitted to various brake calipers. The standard actuators are basically all low pressure devices in either spring or fluid set. We make a large variety of actuators for high pressure fluid applied applications, as well as high and medium pressure spring applied actuators. If you have any specific requirements please let us know. Most of our calipers are also available in standard or side-mount version. Our Engineering Department will be pleased to come up with a solution to suit your application.

Typical Fluid Applied Actuator

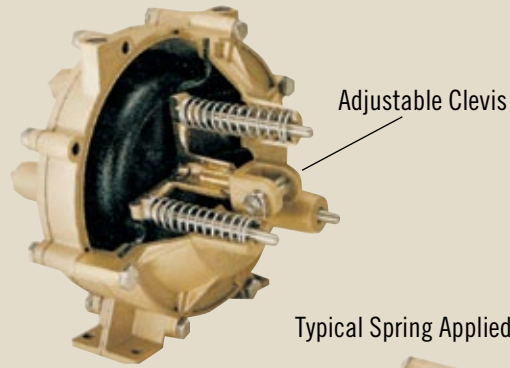

Typical Spring Applied Actuator

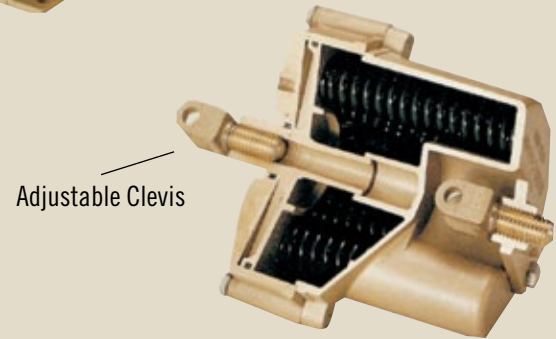

CALIPER	5029		5029	5030		5042		5043		5044		5045		5046		5047		5048		5049	
	-A	-S	-CM	-A	-S	-A	-S	-A	-S	-A	-S	-A	-S	-A	-S	-A	-S	-A	-S	-A	-S
Weight (lbs.)	516		550	486		822															
Maximum Clamp Force (lbs.)	60,000			72,000		96,000		113,000		116,000		126,000		147,000		162,000		180,000		198,000	
Lever Ratio	4.2:1		3.05:1	5.0:1		4.125:1		4.7:1		4.1:1		4.5:1		4.1:1		4.5:1		4.1:1		4.5:1	
Actual Force Each Side (lbs. per actuator)	3,571			3,600		5,818		6,010		7,073		7,000		8,963		9,000		10,975		11,000	
Number of Levers	4			4		4		4		4		4		4		4		4		4	
Total Shoe Area (in. <sup>2</sup> )	492			346		567		397		602		423		602		423		602		423	
Lining Thickness (in.)	.75			.70		.75		.75		.75		.75		.75		.75		.75		.75	
Max. Allowance Lining Wear (in.)	0.50			0.50		0.50		0.50		0.50		0.50		0.50		0.50		0.50		0.50	
H.P. Hour	61,500		43,250		70,875		49,625		75,250		52,875		75,250		52,875		75,250		52,875		
Disc Thickness (in.)	2, 3, 4			2, 3, 4		2, 3, 4		2, 3, 4		2, 3, 4		2, 3, 4		2, 3, 4		2, 3, 4		2, 3, 4		2, 3, 4	
Disc Diameter (in.)	54.5 - 84			48 - 72		60.5 - 84		48 - 84		60.5 - 84		54 - 84		60.5 - 84		54 - 84		60.5 - 84		54 - 84	
Disc Rubbing Face Width (in.)	10			7		10		7		10		7		10		7		10		7	
Pipe Fitting <i>Fluid Applied</i>	4 of 9/16-18 ORB		2 of 3/8" N.P.T	4 of 9/16-18 ORB		4 of 3/4-16 ORB		4 of 3/4-16 ORB		4 of 3/4-16 ORB		4 of 7/8-14 ORB		4 of 7/8-14 ORB		4 of 7/8-14 ORB		4 of 7/8-14 ORB		4 of 7/8-14 ORB	
Max. Volume (in. <sup>3</sup> ) <i>Fluid Applied</i>	72		100	72		120		120		160		160		190		190		230		230	
Max. Working Pressure (P.S.I) - A <i>Air Applied</i>	100		100	100		95		95		90		90		95		95		98		98	
Pipe Fitting <i>Spring Applied</i>	2 of 7/8-14 ORB 2 of 3/4-16 ORB		3/8 NPT	2 of 7/8-14 ORB 2 of 3/4-16 ORB		2 of 7/8-14 ORB 2 of 3/4-16 ORB		2 of 7/8-14 ORB 2 of 3/4-16 ORB		2 of 7/8-14 ORB 2 of 3/4-16 ORB		2 of 7/8-14 ORB 2 of 3/4-16 ORB		2 of 7/8-14 ORB 2 of 3/4-16 ORB		2 of 7/8-14 ORB 2 of 3/4-16 ORB		2 of 7/8-14 ORB 2 of 3/4-16 ORB		2 of 7/8-14 ORB 2 of 3/4-16 ORB	
Max. Released Pressure (P.S.I) - S <i>Spring Applied</i>			100			100		100		100		100		100		100		100		100	
Max. Volume (in. <sup>3</sup> ) <i>Spring Applied</i>	100		110	100		160		160		190		190		230		230		260		260	
Spring Applied Hydraulic Release (P.S.I)	1,800			1,800		1,800		1,800		2,000		2,000		1,500		1,500		1,200		1,200	



# KOBELT BRAKE CALIPERS

## WHY ARE KOBELT BRAKE CALIPERS THE BEST?

Kobelts calipers are designed for the harshest environments. Regular inspection and maintenance, however, are required as per our installation and maintenance instructions.

All calipers are lever operated, which keeps the actuator away from the heat of the disc. The actuators themselves are of the low pressure type, requiring maximum 100 P.S.I. (6.9 bar) for pressure applied brakes and maximum 140 P.S.I. (9.6 bar) fully released for spring applied calipers. Either air or hydraulic pressure can be used. For applications with high-pressure hydraulics, special actuators are available. All actuators have adjustable clevises to adjust the clearance between the disc and the shoe. This can compensate for brake lining wear as well as maintain the torque on spring applied calipers. On fluid applied brake calipers air consumption can be reduced by maintaining little clearance between the shoe and the disc.

The pressure applied to the brake is absolutely proportional to the brake torque itself. Therefore, our actuators, both fluid and spring applied, lend themselves extremely well to applications requiring precise control over the brake torque. All brake calipers, except Model 1720 use floating brake shoes. A patented balancing link is utilized to keep the shoes parallel to the disc, which ensures even lining wear across the whole shoe. Spring applied calipers are furthermore equipped with an equalizing link. This linkage arrangement keeps the shoes centered in relation to the disc. This is useful, should the caliper be installed on a horizontally rotating disc where one of the brake shoes could cause drag. All of our calipers have a large shoe area, giving long lining life. The linings are asbestos-free.

Kobelts Manufacturing spends a tremendous amount of time designing new products, and we are committed to prototyping, cycle testing and stress analysis to ensure our products are dependable, durable and reliable in the field. Our competitors have tried to imitate our products, but the dependability of a Kobelt disc brake is unsurpassed.

Many years ago, Kobelt Manufacturing built 2 test stands for in-house testing of disc brakes. The 650 HP test unit provided us with invaluable information and gave us the opportunity to

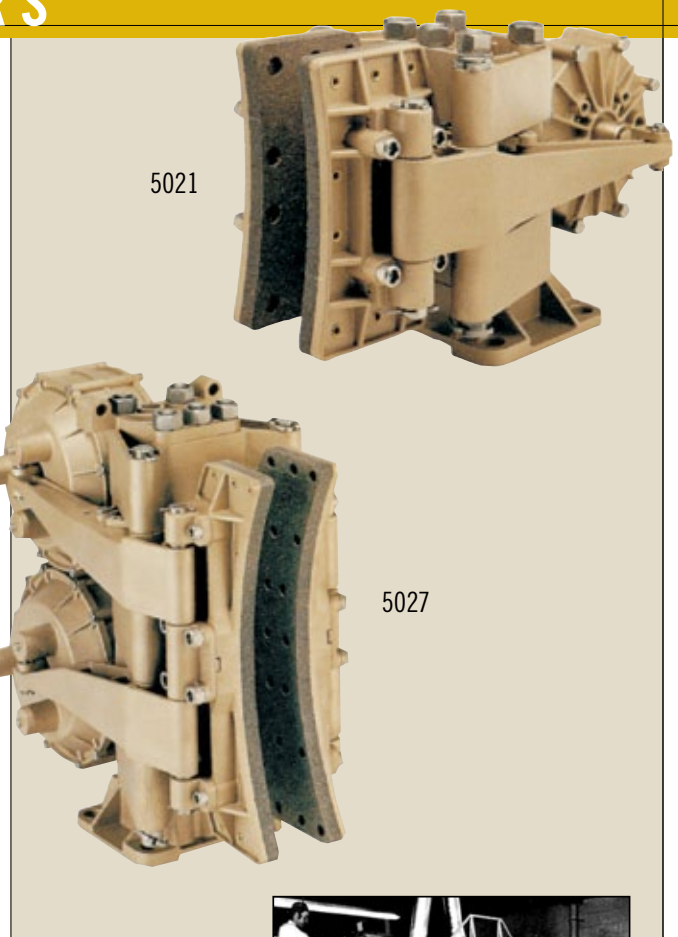

observe every detail of disc brake performance under variable and extreme conditions. Information of this nature is not available in text books.

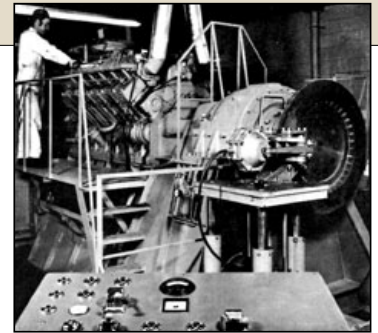

Over the years, our engineering department has been granted many patents which put these brakes in a class by themselves. Further patents are still pending, underlining our commitment to advance disc brake technology which benefits all users.

Kobelts disc brakes are manufactured under one or more of the following patent numbers. Further patents pending.

Canadian Patent Numbers	U.S. Patent Numbers
895693	3722636 4164993
922603	3815471 4236608
1069066	4013148 4393962
1072025	4060153 4572335
1158181	4108285 7,857,109 B2
1176187	4121697

Kobelts calipers are made entirely of die cast silicone bronze with stainless steel hardware. Some models have steel tie rods. The standard lining supplied is asbestos-free with a co-efficient of friction between .45 to .55. Patented balancing links are used to ensure even lining wear. All calipers are available with shims between the shoe and the bearing to adapt to thinner discs. Most of our actuators are of the low-pressure type. Air or hydraulic pressure can be used to either apply or release the brake. The pressure applied brakes have a maximum pressure of 100 P.S.I.

To fully release a spring applied brake is 140 P.S.I. For low pressure spring applied calipers the pressure range could be anywhere from 100 to 140 P.S.I. to fully release the brake. The maximum pressure in most cases will be 250 P.S.I. For high pressure spring applied calipers the release pressure could be anywhere from 1200 to 2000 P.S.I. depending on the model.

Remember to keep the clearance between shoes and disc at minimum for spring applied calipers.

If a quick or rapid response is required, one should select air for air applied and spring applied calipers. Large lines and valves are required for quick response.

Over the last few months, our engineering department has developed a selection of new brake calipers and discs. The models 5029 and 5030 are die cast in bronze with stainless steel hardware except for the tie rods which are made out of 4140 steel. The models 5042 to 5049 mainframes and levers are made in ductile iron, whereas the actuators and shoes are made in bronze with stainless steel hardware and steel tie rods. The model 5049 has a maximum torque of 198,000 lbs – *see our tables for details*.

We have also applied for a patent for a new failsafe braking system, which does not incorporate springs. Further information on this will be available once the patent is granted.

Kobelts Manufacturing Co. Ltd. is also developing direct-acting hydraulic brake calipers. Again, we have applied for a patent on this design and believe that it will be a great improvement over the present state of technology.

CONSULT KOBELT MANUFACTURING FOR MORE DETAILS.

*Kobelts Manufacturing Co. Ltd. reserves the right to make any changes without notice.*

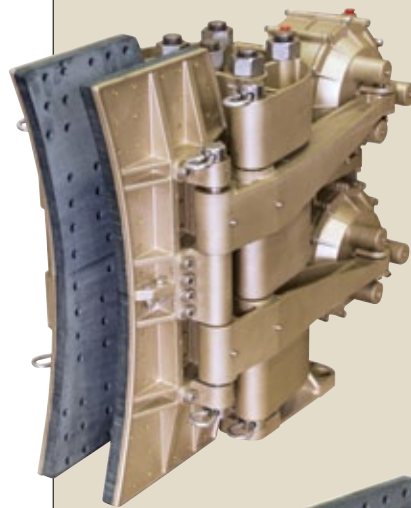

5029-A

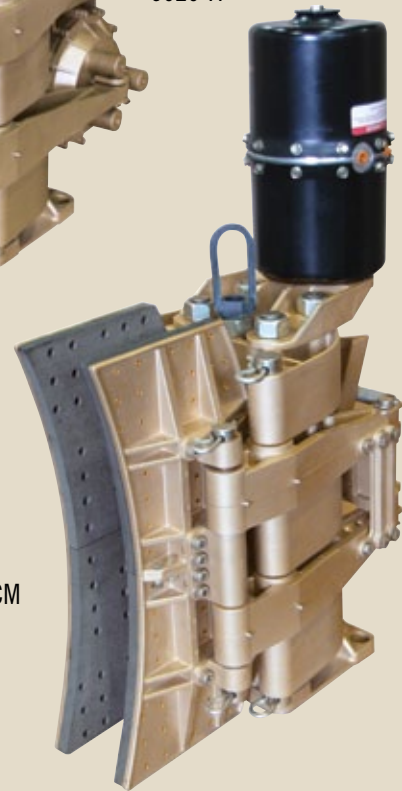

5029-CM

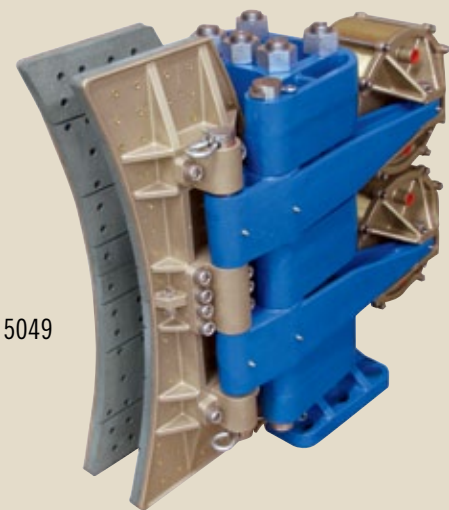

5042 - 5049

# 5019-5028 DIE CAST BRAKE CALIPERS

All of the new brake models 5029 to 5049 are designed for a standard disc thickness of 4". All of these calipers are available with shim kits that allow shimming the caliper down to 3" and 2" thick discs.

For emergency brake applications, it is best to make the disc out of solid steel, since it is a better heat sink than a ventilated disc. A solid steel disc takes longer to cool, therefore, it is for emergency applications only. Solid steel discs can be made locally wherever the customer is located as the transportation costs could be quite high.

Figures in table at right refer to one brake per disc.  
*More brakes per disc are available.*

\* Brakes 5022, 5026, 5027 and 5028 have alloy steel tie rods.

CALIPER MODEL	Disc Diameter		Maximum Torque		Dim. "E"		Dim. "G" (approx.)	
	in.	mm.	ft. - lbs.	kg.-m.	in.	mm.	in.	mm.
<b>5019</b> 3/4" x 2" Disc	9	229	624	86	5.56	141	12.06	306
	12	305	912	126	7.06	179	13.56	344
	15	381	1201	166	8.56	217	15.06	383
	18	457	1490	206	10.06	256	16.56	421
	20	508	1682	233	11.06	281	17.56	446
<b>5020</b> 1.25" x 2.5" Disc	12	305	1471	203	7.13	181	17.13	435
	15	381	1975	273	8.63	219	18.63	473
	18	457	2479	343	10.13	257	20.13	511
	21	533	2982	412	11.63	295	21.63	549
	24	610	3486	482	13.13	333	23.13	587
	27	686	3990	552	14.63	372	24.63	626
<b>5021</b> 2" x 4" Disc	30	762	4494	621	16.13	410	26.13	664
	18	457	2227	308	9.63	245	19.38	492
	20	508	2563	354	10.63	270	20.38	518
	25	635	3402	470	13.13	334	22.88	581
	30	762	4242	586	15.63	397	25.38	645
	35	889	5082	703	18.13	461	27.88	708
	40	1016	5921	819	20.63	524	30.38	772
<b>5022*</b> 2" x 4" Disc	45	1143	6760	935	23.13	588	32.88	835
	50	1270	7600	1051	25.63	651	35.38	899
	18	457	4198	580	9.13	232	18.87	479
	20	508	4870	673	10.13	257	19.87	505
	25	635	6549	905	12.63	321	22.37	568
	30	762	8229	1138	15.13	384	24.87	632
	35	889	9908	1370	17.63	448	27.37	695
<b>5023</b> 2" x 4" Disc	40	1016	11,587	1602	20.13	511	29.87	759
	45	1143	13,267	1834	22.63	575	32.37	822
	50	1270	14,946	2066	25.13	638	34.87	886
	18	457	3890	538	9.63	245	20.50	521
	20	508	4476	619	10.63	270	21.50	546
	25	635	5943	822	13.13	334	24.00	610
	30	762	7410	1024	15.63	397	26.50	673
<b>5024</b> 2" x 4" Disc	35	889	8876	1227	18.13	461	29.00	737
	40	1016	10,343	1430	20.63	524	31.50	800
	45	1143	11,810	1633	23.13	588	34.00	864
	50	1270	13,276	1835	25.63	651	36.50	927
	18	457	6116	846	10.00	254	24.00	610
	20	508	7060	976	11.00	279	25.00	635
	25	635	9419	1302	13.50	343	27.50	699
<b>5025</b> 2" x 4" Disc	30	762	11,779	1629	16.00	406	30.00	762
	35	889	14,138	1955	18.50	470	32.50	826
	40	1016	16,498	2281	21.00	533	35.00	889
	45	1143	18,857	2607	23.50	597	37.50	953
	50	1270	21,217	2933	26.00	660	40.00	1016
	30	762	6997	967	15.42	392	27.92	709
	35	889	8570	1185	17.92	455	30.42	773
<b>5026*</b> 4" x 7" Disc	40	1016	10,143	1402	20.42	519	32.92	836
	48	1219	12,660	1750	24.42	620	36.92	938
	30	762	12,719	1758	15.14	385	27.14	689
	35	889	15,652	2164	17.64	448	29.64	753
	40	1016	18,586	2570	20.14	512	32.14	816
	48	1219	23,279	3218	24.14	613	36.14	918
	54	1372	26,800	3705	27.14	689	39.14	994
<b>5027*</b> 2" x 4" Disc	60	1524	30,320	4192	30.14	766	42.14	1070
	66	1676	33,840	4679	33.14	842	45.14	1147
	30	762	20,874	2886	15.75	400	29.25	743
	35	889	25,274	3494	18.25	464	31.75	806
	40	1016	29,674	4103	20.75	527	34.25	870
	45	1143	34,074	4711	23.25	591	36.75	933
	50	1270	38,474	5319	25.75	654	39.25	997
<b>5028*</b> 4" x 10" Disc	42.5	1080	26,875	3716	21.00	533	34.60	879
	48.5	1232	32,155	4446	24.00	610	37.60	955
	54.5	1384	37,435	5176	27.00	686	40.60	1031
	60.5	1537	42,715	5906	29.80	757	43.40	1102
	72	1829	52,835	7305	35.80	909	49.40	1255
	84	2134	63,395	8765	41.80	1062	55.40	1407



# CALIPER DIMENSIONS AND SPECIFICATIONS

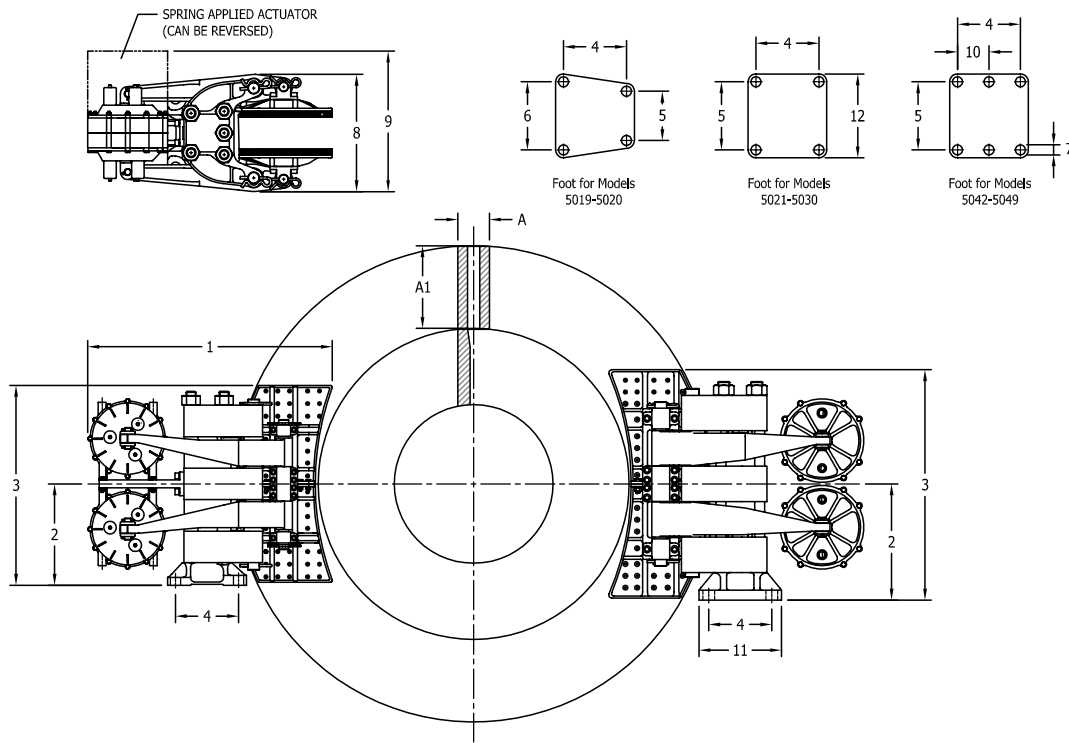

Caliper Model	Max. Clamp Force*		Weight**		All Dimensions in Inches													
	lbs	kg	lbs	kg	A	A1	1	2	3	4	5	6	7	8	9	10	11	12
5019	5250	2381	15	7	0.75	2.00	9.87	3.00	5.56	2.18	1.87	3.00	3/8	4.81	6.56		3	3-7/8
5020	9160	4155	36	16	1.25	2.75	14.00	4.00	7.62	3.12	2.75	3.75	1/2	6.50	8.12		4	4-5/8
5021	9160	4155	53	24	2.00	4.25	14.81	4.75	7.50	3.75	5.50		5/8	7.75	8.75		5	6-3/4
5022	18320	8310	92	42	2.00	4.25	15.25	8.00	15.25	3.75	5.50		5/8	7.75	8.75		5	6-3/4
5023	16000	7256	52	24	2.00	4.25	16.00	4.85	9.00	3.75	5.50		5/8	9.00	12.00		5	6-3/4
5024	25740	11673	97	44	2.00	4.25	19.12	6.50	11.87	4.50	5.75		3/4	9.50	11.50		6	7-1/4
5025	17160	7784	104	47	4.00	7.00	20.63	6.50	11.87	4.75	7.50		3/4	11.00	12.70		6-1/4	9
5026	32000	14512	177	80	4.00	7.00	20.75	9.50	18.25	4.75	7.50		3/4	11.00	12.70		6-1/4	9
5027	48000	21769	165	75	2.00	4.25	20.12	9.50	18.37	4.50	5.75		3/4	9.50	11.50		6	7-1/4
5028	48000	21769	330	150	4.00	10.5	25.63	12.75	24.23	5.20	7.00		1	11.94	13.35		6-3/4	8-5/8
5029	60000	27216	516	234	2,3,4	10.5	31.06	12.88	25.38	8.00	8.63		1-1/4	14.90	16.8		10	10-5/8
5030	72000	32659	486	220	2,3,4	7	28.25	12.88	25.38	8.00	8.63		1-1/4	14.90	16.8		10	10-5/8
5042	96000	43545	822	373	2,3,4	10.5	32.4	14.75	29.25	8.00	11.75		1-1/2	14.90	17.3	4.00	10-1/2	14-1/4
5043	113000	51256			2,3,4	7	31.0	14.75	29.25	8.00	11.75		1-1/2	14.60	17.0	4.00	10-1/2	14-1/4
5044	116000	52617			2,3,4	10.5	35.5	16.0	31	8.00	12.00		1-3/4	15.90	20.0	4.00	10-5/8	14-5/8
5045	126000	57153			2,3,4	7	34.3	16.5	31	8.00	12.00		1-3/4	15.90	20.3	4.00	10-5/8	14-5/8
5046	147000	66678			2,3,4	10.5	36.2	16.5	31.5	8.50	13.50		2	16.0	20.8	4.25	11-1/2	16-1/2
5047	162000	73482			2,3,4	7	33.5	16.5	31.5	8.50	13.50		2	16.0	20.8	4.25	11-1/2	16-1/2
5048	180000	81674			2,3,4	10.5	36.8	16.5	31.5	8.50	13.50		2	16.0	20.7	4.25	11-1/2	16-1/2
5049	198000	89811			2,3,4	7	34.0	16.5	31.5	8.50	13.50		2	16.0	20.7	4.25	11-1/2	16-1/2

Some models are also available in a sidemount configuration. \* Clamping forces for fluid and spring applied calipers are the same.

\*\* Weights are for fluid applied calipers, spring applied calipers weigh approx. 12% more.

Kobel Manufacturing Co. Ltd. reserves the right to make any changes without notice.

# CALIPER DIMENSIONS AND SPECIFICATIONS

Model	Max. Clamp Force		Disc Diameter		Dim E		Dim G		Max. Torque	
	lbs	kg	in	mm	in	mm	in	mm	lbs. ft	kg. m
5029 Rubbing Face 10"	60,000	27,216	54.5	1,384	26.81	681	45.96	1,168	46,508	6,430
			60.5	1,537	29.87	759	49.0	1,245	53,108	7,342
			66	1,676	32.62	829	51.75	1,314	59,158	8,179
			72	1,829	35.62	905	54.75	1,391	65,758	9,091
			84	2,134	41.68	1,059	60.75	1,543	78,958	10,916
5030 Rubbing Face 7"	72,000	32,659	48	1,219	24.00	610	42.08	1,069	50,371	6,964
			54	1,372	27.00	686	45.08	1,145	58,291	8,059
			60	1,524	30.00	762	48.08	1,221	66,211	9,154
			66	1,676	33.00	838	51.08	1,297	74,131	10,249
			72	1,829	36.00	914	54.08	1,374	82,051	11,344
5042 Rubbing Face 10"	96,000	43,545	60.5	1,537	29.87	759	49.57	1,259	83,670	11,568
			66	1,676	32.62	829	52.32	1,329	93,350	12,906
			72	1,829	35.62	905	55.32	1,405	103,910	14,366
			84	2,134	41.68	1,059	61.38	1,559	125,030	17,286
5043 Rubbing Face 7"	113,000	51,256	48	1,219	23.85	606	44.16	1,122	77,170	10,669
			54	1,372	26.85	682	47.16	1,198	90,635	12,530
			60	1,524	29.85	758	50.16	1,274	103,065	14,249
			66	1,676	32.85	834	53.16	1,350	115,495	15,968
			72	1,829	35.85	911	56.16	1,426	127,925	17,686
			84	2,134	41.85	1,063	62.16	1,579	152,785	21,123
5044 Rubbing Face 10"	116,000	52,617	60.5	1,537	30.68	779	51.78	1,315	98,251	13,584
			66	1,676	32.43	824	54.53	1,385	109,948	15,201
			72	1,829	35.43	925	57.53	1,461	122,708	16,965
			84	2,134	42.43	1,078	63.53	1,614	148,228	20,493
5045 Rubbing Face 7"	126,000	57,153	54	1,372	27.37	695	50.05	1,271	99,907	13,813
			60	1,524	30.50	775	53.17	1,351	114,345	15,809
			66	1,676	33.50	851	56.17	1,427	128,205	17,725
			72	1,829	36.50	927	59.17	1,503	142,065	19,641
			84	2,134	42.50	1,080	65.17	1,655	169,785	23,474
5046 Rubbing Face 10"	147,000	66,678	60.5	1,537	31.22	793	52.45	1,332	124,509	17,214
			66	1,676	33.97	863	55.20	1,402	139,331	19,263
			72	1,829	36.97	939	58.20	1,478	155,501	21,499
			84	2,134	42.97	1,091	64.20	1,631	187,841	25,970
5047 Rubbing Face 7"	162,000	73,482	54	1,372	27.87	708	49.07	1,246	128,453	17,759
			60	1,524	31.00	787	52.19	1,326	147,014	20,325
			66	1,676	33.00	838	55.19	1,402	164,835	22,789
			72	1,829	36.00	914	58.19	1,478	182,654	25,253
			84	2,134	42.00	1,067	64.19	1,630	218,294	30,180
5048 Rubbing Face 10"	180,000	81,647	60.5	1,537	31.22	793	52.81	1,341	152,460	21,078
			66	1,676	33.97	863	55.56	1,411	170,610	23,588
			72	1,829	36.97	939	58.56	1,487	190,410	26,325
			84	2,134	42.97	1,091	64.56	1,640	230,010	31,800
5049 Rubbing Face 7"	198,000	89,811	54	1,372	27.87	708	49.60	1,260	156,997	21,706
			60	1,524	31.00	787	52.70	1,339	179,685	24,842
			66	1,676	33.00	838	55.70	1,415	201,465	27,853
			72	1,829	36.00	914	58.70	1,491	223,245	30,865
			84	2,134	42.00	1,067	64.70	1,644	266,805	36,887

## THE ILLUSTRATION BELOW SHOWS A TYPICAL AIR APPLIED DISC BRAKE ARRANGEMENT.

The 2nd caliper does not necessarily have to be installed, but in some cases it may be necessary in order to increase the torque. An air compressor of sufficient volume and storage tank are required.

The control valve can be either solenoid operated or simply a 3-way valve which could function as either an “on/off” or a variable pressure device, giving absolute complete control

over the brake functions. In some cases, the control valves do require lubrication to maintain accuracy and avoid sticking.

If a fast-acting response is required, one must install generous-sized valves and lines. In order to dump the air more rapidly, a quick release valve should be installed near the brake caliper. If the requirement is to apply the brake more slowly, a flow control can be installed in the pressure line.

Diaphragm type brake actuators are extremely sensitive to air pressure changes and do not require lubrication.

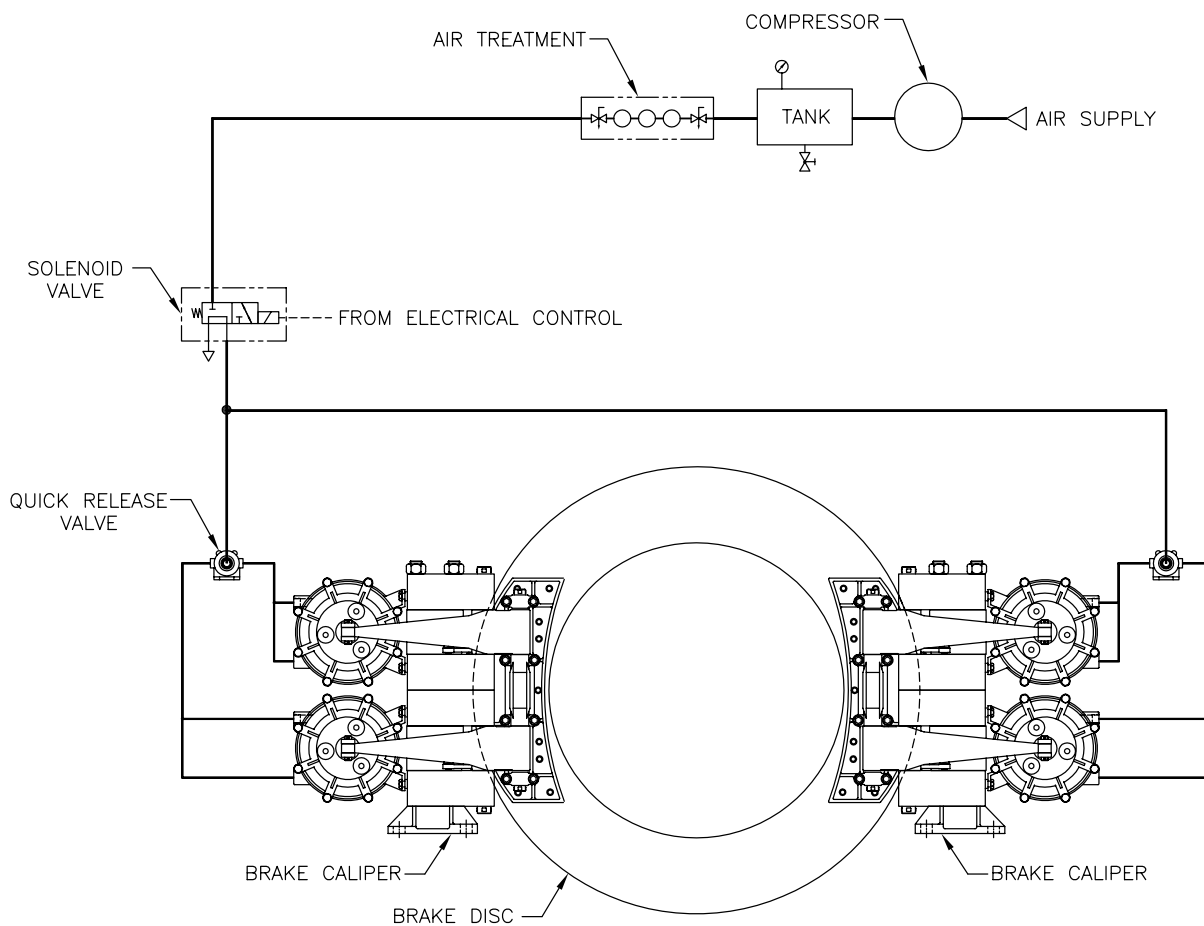

*Kobel Manufacturing Co. Ltd. reserves the right to make any changes without notice.*



# 1720/5054 SAND CAST HIGH ENERGY INPUT BRAKE CALIPERS

These calipers were designed for extremely high energy input applications. They have a large shoe area which gives them long brake lining life. The brake lining supplied with these calipers has a coefficient of friction between .45 to .55. These calipers are available pressure or spring applied. Air or hydraulic pressure can be used to either apply or release the brake. The maximum pressure for pressure applied models is 100 P.S.I. (6.9 bar) and 140 P.S.I. (17 bar) for spring applied brakes. The torque ratings are the same for either version.

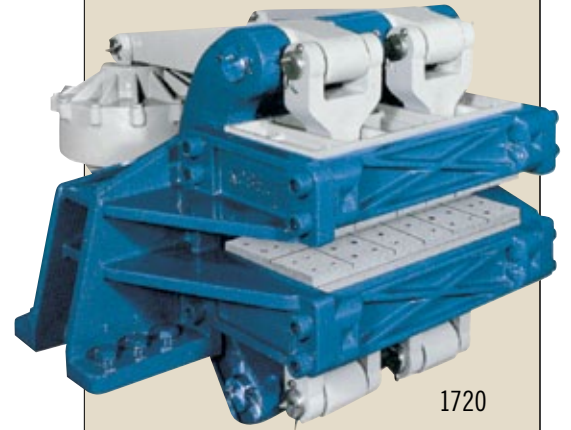

1720

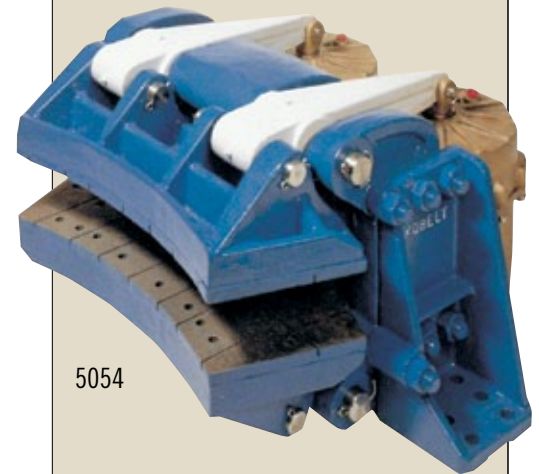

5054

Caliper Number	Disc Diameter		Maximum Torque		Dim. E		Dim. G	
	in.	mm.	ft.-lbs.	kg.-m.	in.	mm.	in.	mm.
5054	48.5	1232	102400	14157	25.75	654	42.75	1086
	54.5	1384	118600	16397	28.75	730	45.75	1162
	60.5	1537	134800	18637	31.75	806	48.75	1238
	72	1829	164600	22757	37.50	953	54.50	1384
	84	2134	197000	27236	43.50	1105	60.50	1537
	96	2438	229400	31716	49.50	1257	66.50	1689
1720	60	1524	231000	31937	29.81	757	50.62	1286
	72	1829	287000	39679	36.00	914	56.81	1443
	84	2134	344000	47560	42.18	1071	63.00	1600
	96	2438	400000	55302	48.18	1224	69.00	1753
	108	2743	456000	63044	54.18	1376	75.00	1905
	120	3048	513000	70925	60.18	1529	81.00	2057

# CALIPER DIMENSIONS AND SPECIFICATIONS

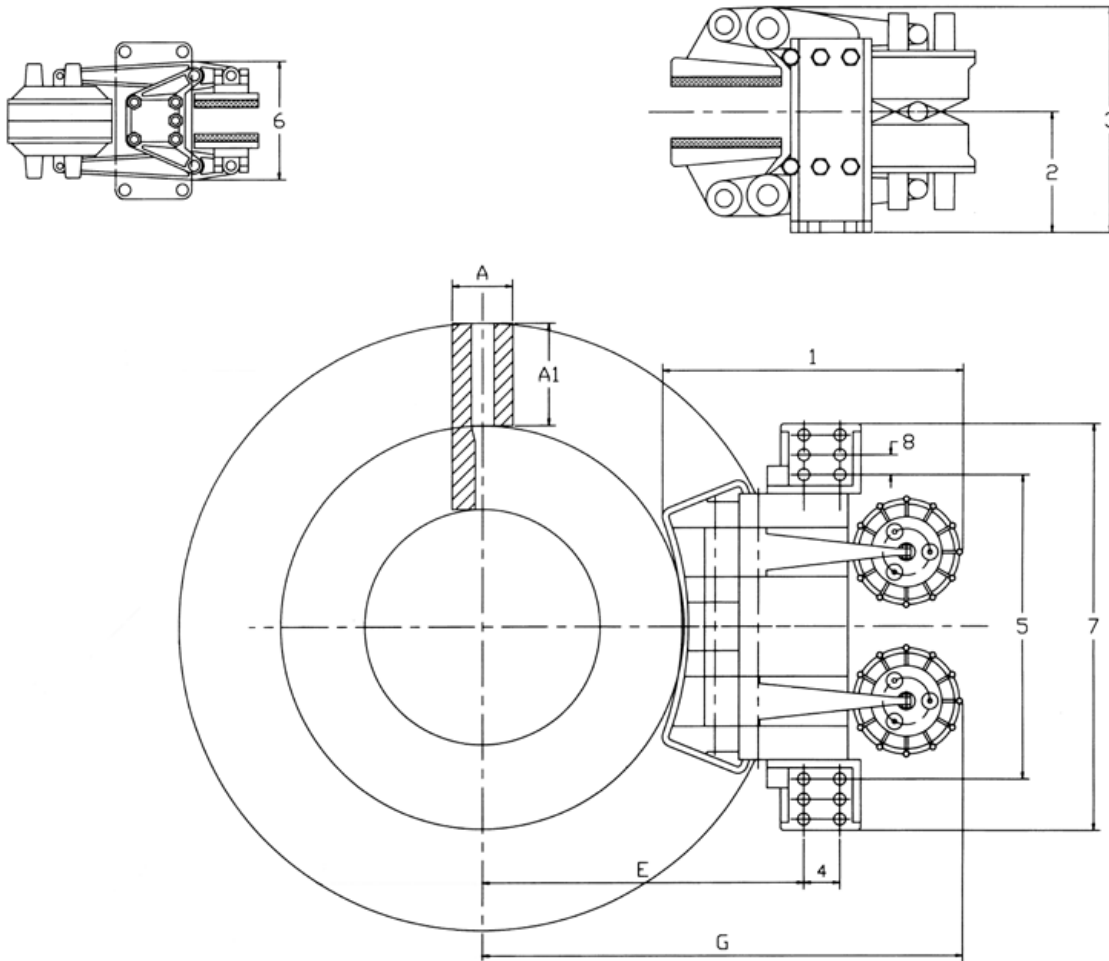

Models: 5040, 5054, 1720

Caliper Number	Max. Clamp Force*		Weight		All Dimensions in Inches									
	lbs.	kg.	lbs.	kg.	A	A1	1	2	3	4	5	6	7	8
5040	49300	22362	570	259	4.00	10.5	29.0	12.75	24.25	7.50	9.25	13.75	11.30	N/A
5054	129600	58776	1600	726	4.00	10.5	31.0	9.37	18.75	3.25	29.62	18.25	40.00	2.00
1720	226000	102494	2475	1122	2.50	11.0	37.0	9.25	24.00	9.50	30.00	29.50	44.25	2.50

\*Clamping forces for fluid and spring applied calipers are the same.

# MEDIUM AND HEAVY DUTY BRAKE DISCS

These brake discs were designed to go with our die cast brake calipers. They are suitable for both fluid applied and spring applied brakes. All discs are ventilated and can be used for medium to heavy-duty applications. Normally, they are cast in ductile iron, however, other materials are available to suit customer requirements.

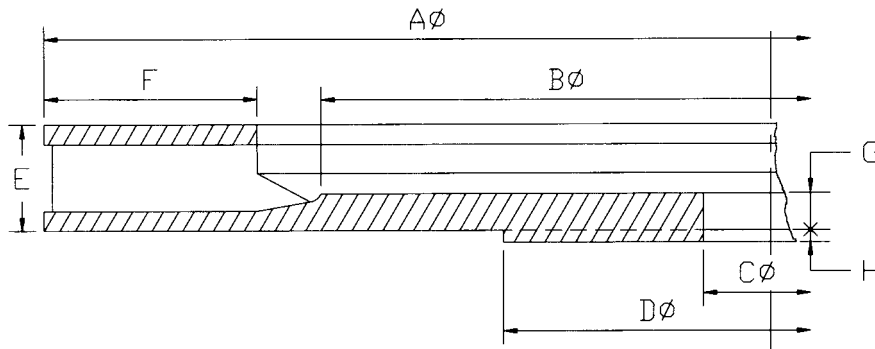
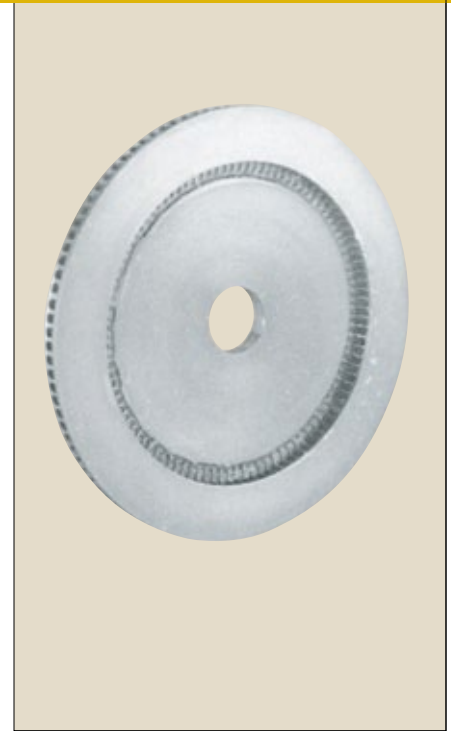

3/4" x 2" Series for Caliper 5019	A Diameter		B Max. Diameter		C Min. Diameter		D Max. Diameter		Max. RPM	Weight*		Act. Rad		
	inch	mm	inch	mm	inch	mm	inch	mm		lbs.	kg.	ft.	m	
	9	229	5	127	2	51	3.75	95	6150	8	4	0.29	0.09	
Dim. E=0.750 in 19mm	12	305	8	203	2	51	5	127	4550	15	7	0.42	0.13	
Dim. F=2.000 in 51mm	15	381	11	279	2	51	6	152	3600	21	10	0.54	0.17	
Dim. G=0.375 in 10mm	18	457	14	356	2	51	7	178	3000	29	13	0.67	0.20	
Dim. H=0.125 in 3mm	20	508	16	406	2	51	8	203	2680	36	16	0.75	0.23	
1-1/4" x 2-1/2" Series for Caliper 5020	12	305	4.5	114	2.0	51	3.75	95	4600	19	9	0.39	0.12	
	15	381	7.5	191	2.5	64	5	127	3650	27	12	0.52	0.15	
	18	457	10.5	267	3.0	76	6	152	3000	37	17	0.65	0.19	
	Dim. E=1.250 in 32mm	21	533	13.5	343	3.5	89	9	229	2550	50	23	0.77	0.23
	Dim. F=2.750 in 70mm	24	610	16.75	425	4.0	102	8	203	2250	64	29	0.89	0.27
	Dim. G=0.625 in 16mm	27	686	19.5	495	4.0	102	12	305	1980	79	36	1.02	0.31
Dim. H=0.250 in 6mm	30	762	22.75	578	4.5	114	10	254	1780	99	45	1.14	0.34	
2" x 4" Series for Calipers 5021, 5022, 5023 5024, 5027	18	457	7	178	3.25	83	7.75	197	3070	74	34	0.58	0.18	
	20	508	9	229	4	102	9.75	248	2750	86	39	0.67	0.20	
	25	635	14	356	3.5	89	9.75	248	2200	118	54	0.88	0.27	
	30	762	19	483	4.5	114	13	330	1800	165	75	1.08	0.33	
	Dim. E=2.00 in 51mm	35	889	24	610	5.5	140	13.75	349	1550	212	96	1.29	0.39
	Dim. F=4.25 in 108mm	40	1016	29	737	6	152	15	381	1350	263	119	1.50	0.46
	Dim. G=0.75 in 19mm	45	1143	34	864	8.25	210	15.75	400	1200	302	137	1.71	0.52
	Dim. H=0.25 in 6mm	50	1270	39	991	10.25	260	19.5	495	1070	358	162	1.92	0.58

\*Weights may vary due to machining.



# BRAKE DISC DETAILS FOR HIGH ENERGY INPUT

These brake discs were developed for medium to high energy input. The patented fin design offers the ultimate in heat transfer and air flow. This disc will accomplish tasks not possible with ordinary ventilated discs.

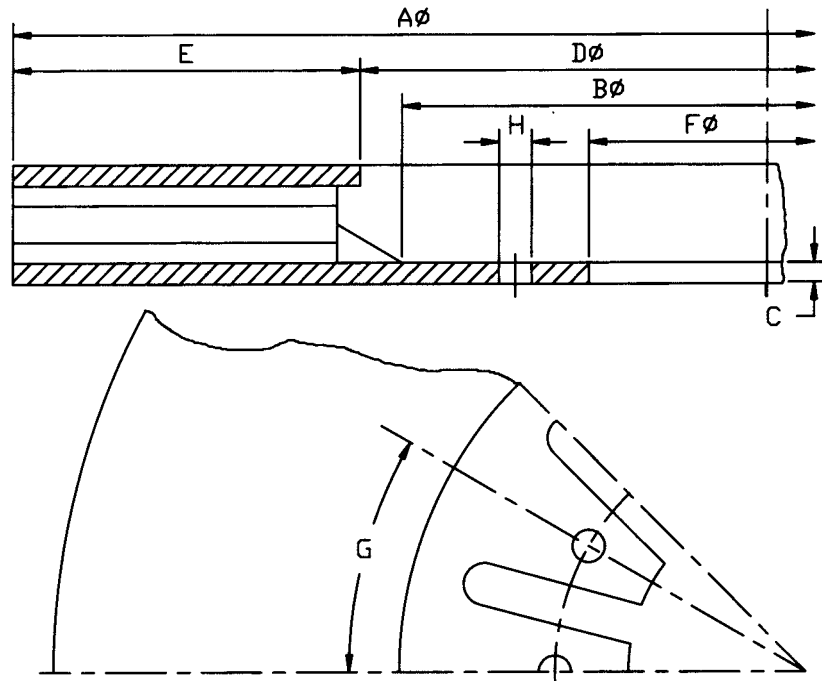

## 4" SERIES BRAKE DISCS

Caliper Number	5025, 5026				5030, 5043				5030, 5043, 5045, 5047, 5049				5028, 5040		5029, 5042, 5044, 5046, 5048				5054
Thickness (in.)	4				4				4				4						
A (in.)	30	35	40	48	54	60	66	72	42.5	48.5	54.5	60.5	72	84	96				
B (in.)	14	18	23	31	36.6	42.6	48.6	54.6	18.5	23.5	29.5	35.5	46	58	70				
C (in.)	1	1	1	1	1 1/8	1 1/8	1 1/8	1 1/8	1	1	1 1/8	1 1/8	1 1/8	1 1/8	1 1/8				
D (in.)	16	21	26	34	39	45	51	57	21.5	27.5	33.5	39.5	50	62	74				
E (in.)	7				7				10				10						
F (Min.) (in.)	8	14	19.5	19.6	27	33	39	46	15	18	23.1	27	38	50	62				
F (Max.) (in.)	11	16	21	29	35	39	45	53	17.5	23.5	25	31	42	54	66				
G (Deg.)	30	30°	20°	20°	18°	18°	15°	15°	30°	30°	18°	18°	15°	15°	15°				
H (customized) (in.)	11/16	11/16	11/16	11/16	1-3/32	1-3/32	1-3/8	1-3/8	11/16	11/16	1-3/32	1-3/32	1-3/8	1-3/8	1-3/8				
WR <sup>2</sup> (lb.ft <sup>2</sup> )	365	635	1,010	1,600	2,950	4,100	5,880	7,690	1,160	2,010	3,010	4,220	9,170	16,600	26,900				
Acting Rad. (ft.)	0.96	1.17	1.37	1.71	1.94	2.19	2.44	2.69	1.33	1.58	1.83	2.08	2.54	3.04	3.54				
Weight (lb.)	380	460	530	690	860	940	1,070	1,150	620	790	890	980	1,450	1,860	2,240				
Max. Cont. HP	65	80	100	120	155	190	220	240	140	170	195	220	280	340	400				
Cont. HP 100 RPM	25	35	45	55	70	110	120	130	55	70	90	150	240	340	400				
Max. RPM	1,800	1,500	1,300	1,100	1,000	900	800	700	1,300	1,100	1,000	900	700	600	500				

## AIR SUPPLY AND TREATMENT OF DRAW WORKS DISC BRAKES

It is of extreme importance that air compressors and storage tanks provide sufficient air during the operation of the brakes and clutches. There must not be any shortage of supply air. It is also equally important that all the air lines between the tanks, control valves and brake actuators are of a generous size. An operator will lose confidence in the rig if the brake response from the control handle is not instant. Actuators and control valves equipped with 'U' cups and 'O' rings require lubrication in order to provide years of trouble-free service. 'O' rings and 'U' cups will become sticky and show wear if not lubricated properly. Diaphragm type actuators do not require lubrication, however, it is recommended that the control valve have a lubricant in order to make it respond accurately.

The main supply line to the control and brake system should be equipped with a filter and regulator. The filter's responsibility is to remove moisture and dirt in the system, and the regulator will provide a constant air pressure to the control system. It is, therefore, important that the compressor pressure be set higher than the air pressure regulator. The oil that is required for the lubricator should be of a hydraulic type with a viscosity of 10 - 32. Heavy oils are not a good solution for lubricators. If the draw works is operating in a cold environment, it is recommended to have an air dryer in the system to remove all moisture. In some cases, in extremely cold locations, it may be necessary to add a lubricator large enough to handle all the air flow. This lubricator should be equipped with a metal bowl and can be filled with methyl hydrate wood alcohol. The wood alcohol must be used sparingly since it is not friendly to most synthetic rubber.

## BRAKE POTS

Kobelt Manufacturing provides three different types of actuators for the disc brake. The most common would be an air only applied actuator which is of a dual diaphragm type and does not require lubricating. These diaphragms provide an optimum accurate and controlled response.

Kobelt Manufacturing also produces a spring applied actuator which is of a piston type, and is equipped with multi spring packs which can be adjusted to suit customer

requirements. This actuator, however, requires lubricating in order to prolong the seal life and its accuracy. It is not as responsive as a diaphragm type.

The third actuator that Kobelt provides is of a truck type called Maxi Brake. This actuator is not manufactured by Kobelt and is of a dual diaphragm type whereby one diaphragm looks after the spring applied portion and the other diaphragm looks after the air applied portion. This combination comes in extremely handy when spring and air applied systems are both required. In order to release the spring brake, air must be accumulated in the spring chamber to compress the spring and release the brake. Now, the air applied portion will provide infinite control over the brake. The more air pressure that is accumulated in this chamber, the more torque the brake will produce. It is, however, very important not to apply the spring portion and air portion at the same time. This could cause an overload on the basic mechanical brake structure.

The Maxi Pot brake actuators are also equipped with a manual release screw whereby the spring portion can be manually released. It is critical that the air be applied to the spring portion so that the threads do not become over stressed when using the manual release screw, because in some actuators the thread screw is not designed to release the actuators without the assistance of air. The spring applied portion is only 60%.

### PLEASE NOTE:

If a customer fails to inform Kobelt Manufacturing of any specific characteristics of the machinery on which our brake assemblies are installed, which could be detrimental to the performance of our brakes, Kobelt Manufacturing will not assume any responsibility. This applies especially to machinery having harmonics, vibrations and crucial rpms since this may adversely affect the performance of our brake disc and caliper.

Upon ordering, please specify all operational details to ensure that you purchase the correct braking system for your individual application. Our representatives are happy to assist you with any questions that you may have, and will guide you towards the right selection for your needs. Furthermore, if our installation and maintenance instructions are not followed the warranties are also void.

# PNEUMATIC CONTROLS

Kobelt pneumatic controls are the finest in the industry. We manufacture all components for any type of pneumatic control system.

This control system features a limitless number of control stations. Additional control stations do not affect the performance of the control system. This means that, regardless of the distance or the force required, the control heads move effortlessly.

The pneumatic control system is one of the most flexible systems we offer. Since the system does not depend on the force you apply – everything is done by air signals – we can automate and synchronize as much, or as little, of your propulsion equipment as desired. The control options are almost limitless. We offer propulsion timing packages with, and without, shaft brakes. A timing system will protect your propulsion equipment. It ensures that the gear box is engaged before you accelerate your engine. The system will allow you to go from full ahead to full astern without damaging your gear box or stalling your engine.

You will find that the pneumatic system is best suited for vessels anywhere between 50 to 600 feet (15 to 180m). For the ultimate in styling, flexibility and for fingertip control, contact your nearest Kobelt distributor about Kobelt pneumatic controls.

Kobelt's pneumatic controls are manufactured under one or more of the following patent numbers. Further patents pending.

## Canadian Patent Numbers

828507  
922594  
923767  
928607  
932600  
936055  
939202  
947619  
964138  
964555

## U.S. Patent Numbers

3455186  
3724970  
3766835  
3783742  
3795110  
3820438  
3826490  
3838630  
3900090

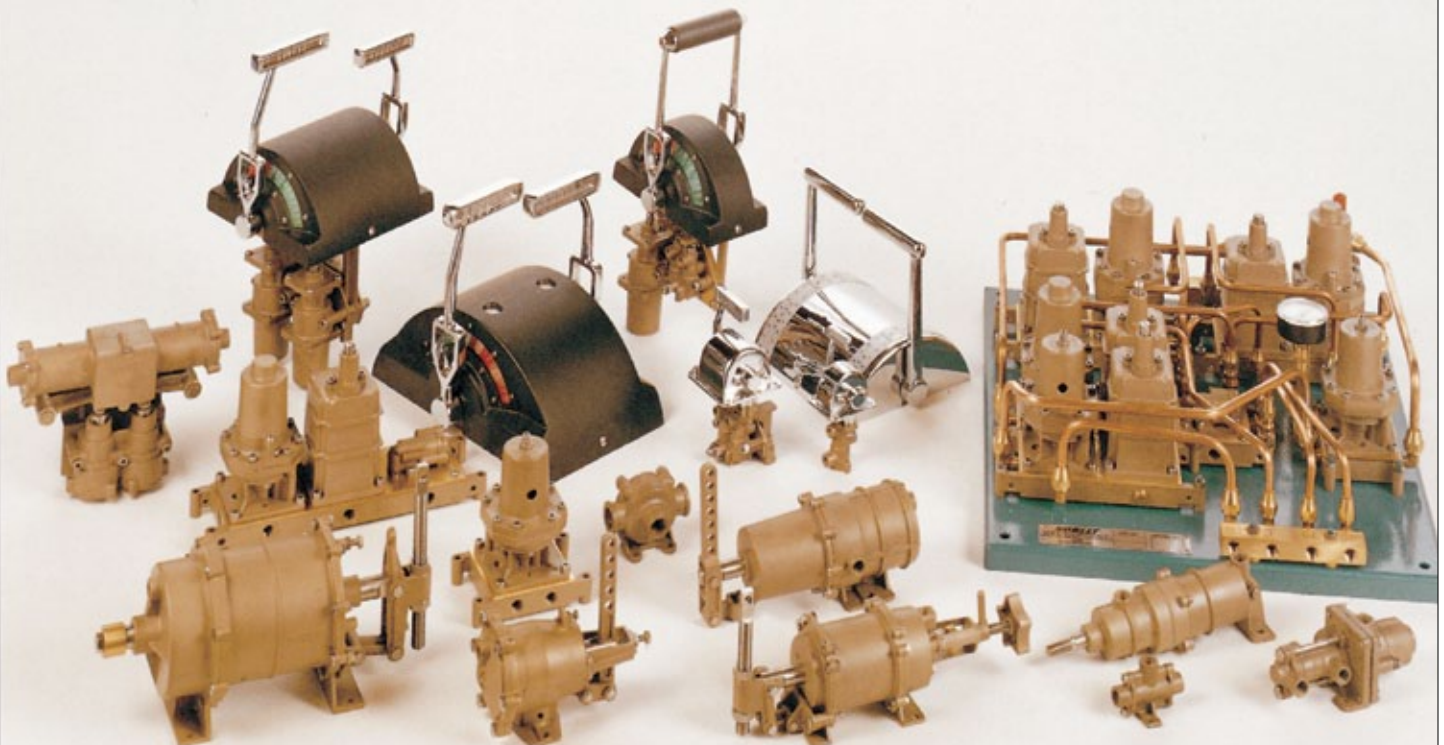



# WE ALSO MAKE...

## PUSH-PULL CONTROLS

Kobelt provides a complete line of mechanical controls, all in die-cast bronze and stainless steel including push/pull controls for single- and multi-station applications. We generally do not recommend the installation of more than two stations with push-pull cables, and this system is dependent largely upon the quality of the cable and the layout of the installation. The mechanical push-pull control is a very simple and easily installed system designed for smaller boats. The equipment controlled by a system of this type must be relatively easy to operate. As a mechanically connected system, push/pull controls use cables to connect control heads to the clutch and throttle. If the total length of cable is less than 50 feet, with minimal bends 15 meters, a push/pull system can work well for you.



## HYDRAULIC STEERING

Kobelt specializes in hydraulic and electro-hydraulic steering systems, including the following integrated systems – manual hydraulic, electric power, power assisted and electronic steering.

The manual hydraulic system works entirely “by hand”, is simple and easy to install, and produces a smooth, simple method for steering. Electric power steering is driven by an electric power pack activated by a jog lever which forces hydraulic oil to the cylinder. The full hydraulic power assisted system operates with a power-assisted cylinder, is very compact and low maintenance, with very few and easy steering wheel turns to hard over. Powered completely by an electronic control system, the electronic system is perfect for large vessels with multiple control stations, offering unlimited options with faster reaction time for steering gear.

In addition to these, hybrid or combined systems are also available. All systems are flexible, cost-efficient and easily integrated into other steering configurations.



## ELECTRONIC CONTROLS

Kobelt offers electronic control systems and individual components to suit all applications. Whether you require a simple or complex system, single or multiple stations, we offer a wide range of control heads, bases, microprocessors, actuators and accessories. We are also able to offer customized solutions to fit your vessel’s specific needs. All Kobelt control components are made of bronze and stainless steel to ensure many years of corrosion-free operation. Clean 12 or 24 volt power is required along with sufficient amperage and voltage. A single cable connects the control heads and the CPU.

We offer three major systems to meet your needs. The simplest, best value is the Mighty Mariner. For more complex systems we offer the 6525 system. If you have a 360° system right-angle drive or Z-drive contact us for details about the 6535 system.



**FOR MORE INFORMATION ON THESE, OR ANY OTHER KOBELT PRODUCT OR SYSTEM,  
PLEASE CONTACT YOUR NEAREST KOBELT DEALER, OR VISIT US AT [WWW.KOBELT.COM](http://WWW.KOBELT.COM)**



*Kobelt Manufacturing, Surrey, British Columbia, Canada*

**E**ver since our humble beginnings in 1962, Kobelt Manufacturing Limited has been committed to manufacturing the finest marine controls in the world. We stress the importance of quality, precision, competitive pricing and prompt delivery. Our team of dedicated production staff is uncompromising in ensuring that we meet the needs of all our valued customers. Our growing reputation in world markets is proof of our commitment to highest possible standards. From our very first line of pneumatic controls we've believed in the simple things—rugged construction, quality materials and prompt delivery to our customers. Today, the technology has changed, but our commitment remains the same. From our innovations in design and performance to our craftsmanship with bronze and stainless steel, our products span the world to further our reputation as an international leader in industrial and maritime technology.

Due to the nature of braking systems, our brake products come with a 1-year limited warranty, with the exception of brake lining for which there is no warranty. The warranty period for products from another manufacturer, components or in whole, will not exceed the terms or conditions under which their warranty was originally extended to Kobelt.

**KOBELT**

8238 129th Street, Surrey  
British Columbia, Canada V3W 0A6  
Sales: 604.590.7313 Fax: 604.590.8313  
sales@kobelt.com www.kobelt.com

5M 08/11  
PRINTED IN CANADA