



Manufacturing Company Limited  
8238 – 129<sup>th</sup> Street  
Surrey, B.C. Canada V3W 0A6  
Telephone: 604-572-3935  
Fax: 604-590-8313  
<http://www.kobelt.com>

## KOBELT MANUFACTURING COMPANY LIMITED

# INSTALLATION & MAINTENANCE INSTRUCTIONS FOR KOBELT DISC BRAKES

Rev. 04/2011

“Leaders in Quality Marine Controls, Steering Gear, and Disc Brakes.”



## **NOTES ON WARRANTY**

Kobel Manufacturing provides installation and maintenance instructions for its products. If these guidelines are not followed, the warranty will be voided.

If our instructions are followed during installation and maintenance, the performance of our products will prove to be most satisfactory. There is nothing like a satisfied customer.

For further instructions, please contact our distributors or visit our website at <http://www.kobel.com>

## **BASIC PRINCIPLE OF OPERATION FOR KOBELT DISC BRAKES**

Low pressure actuators with large areas are used to apply the force against a mechanical lever, multiplying the brake application forces with a lever ratio of approximately 3.6:1 and up to 5:1. The application force of the actuator is therefore directly related to the brake force. Variation in the actuator pressure results in an absolute proportional brake torque reduction or increase. This results in very high torque capabilities.

### **DISK BRAKE LININGS**

Kobelt engineers have developed a unique disc brake lining material. Available only from Kobelt, it offers a combination of advantages over most other materials. The Kobelt brake lining has a maximum operating temperature of 700°F and is relatively stable throughout the whole temperature range but it must be burnished in order to arrive at its full potential.

### **Discs**

Kobelt brake discs are available in a variety of diameters and thicknesses to accommodate nearly unlimited combinations of torque and energy input requirements. Kobelt provides four different types of standard discs.

Most of Kobelt discs are of a cast material. The grain structure in the castings is not always equal throughout the whole casting and, depending on the machining process, there could be quite an imbalance as far as material is concerned. This imbalance in the casting could be detrimental to high speed rotating discs, due to some vibration, it is therefore necessary to balance discs at elevated r.p.m. Balancing must be requested by the customer. We, at Kobelt, have the ability to do static balancing, which is extremely accurate, however, if a real fine balancing is required it would have to be done dynamically and this has proven to be quite expensive.

- (1) Medium energy input - solid steel discs. These discs are used for infrequent stopping applications. The energy in these discs is absorbed rapidly in the disc mass, but the disc requires a long cooling time.
- (2) Medium energy input - ductile iron, air cooled discs. These discs are designed for general purposes and will perform much better than a solid disc at higher speeds and continuous or intermittent brake applications, since the fan action of the disc will increase the heat transfer by drawing air over the internal cooling fins.
- (3) High energy input - ductile iron, internal air cooled discs. These patented discs provide the most refined internal cooling fin design and are ideally suited for continuous high energy input at higher speeds.

- (4) Very high energy input - internal water cooled discs. These patented discs, designed for high torque, low speed applications, have internal water passages which permit a high rate of energy dissipation.

Some Kobelt brake discs are available segmented (half or quarter). The purpose of these segmented discs is to facilitate disc installation or removal on disc adaptor flanges located between machinery parts which do not allow for a one piece disc installation without the removal of other components.

#### **AIR COOLED BRAKE DISCS**

Air cooled brake discs are designed to pump air efficiently when rotating quickly. In most cases a guard or some protective cover is needed to shield the brake disc. An improper design of cover may cause air recirculation through the disc or radiant heat reflection, which could result in the disc overheating. The cooling air pumped through the disc must be exhausted away from the disc to allow fresh, cool air to enter the inner vent openings of the disc. No back pressure should be generated on the exhaust side of the disc.

**CAUTION:** *Under no circumstances should the disc cooling fins be painted or shielded.*

***Stainless Steel discs are not suitable for dynamic braking applications because of their poor thermal conductivity. The stainless steel disc will destroy itself in short order.***

#### **BRAKE ACTUATORS (POTS)**

Kobelt Manufacturing provides three different types of actuator for the disc brakes. The most common would be an air applied only actuator which is of a dual diaphragm type and does not require lubricating. These diaphragms provide an optimum accurate and controlled response.

Kobelt Manufacturing also provides a spring applied actuator, which is a piston type actuator. This actuator is equipped with a multi-spring pack and the springs can be adjusted to customer requirements. This actuator however, requires lubricating in order to prolong the seal life and its accuracy. This actuator is not as responsive as a diaphragm type. The release pressure for spring applied air release actuator is 120 psi.

The third actuator that Kobelt provides is of a truck type called Maxi Brake. This actuator is not manufactured by Kobelt and is of a dual diaphragm type whereby one diaphragm looks after the spring applied portion and the other looks after the air applied portion. The combination comes in extremely handy when spring and air applied are both required. In order to release the spring brake, air must be accumulated in the spring chamber to compress the spring and release the brake. Then the air applied portion will now provide infinite control over the brake. The more air pressure that is accumulated in this chamber, the more torque the brake will produce. It is, however,

important not to apply the spring portion and the air portion at the same time. This could cause an overload on the basic mechanical brake structure.

### WEDGE TYPE BRAKE CALIPER (CM TYPE)

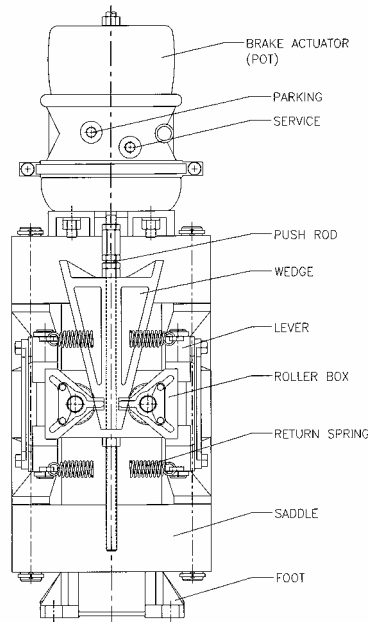

It also has a manual release screw which fits on the top of the brake actuator and allows the spring portion of the brake to be released manually. The emergency portion of the maxi actuator is only 60% of the air operating service portion. However, the further out the actuator extends the spring tension loses application force.

The air applied portion is used for general operation whereas the emergency type is used for parking in case of air pressure failure. It is not recommended to use both the air applied and spring applied at the same time. The wedge roller assembly is actuated by a push rod from the actuator. A minimum clearance must be maintained between the brake lining and the disc. The clearance can be practically zero, the smaller the clearance the less the air consumption. Failing to adjust the wedge down as lining wear occurs may result in brake failure as there is not enough mechanical movement to apply the brake shoe against the disc.

The port for the parking brake must be connected to a three-way valve and a quick release valve. The quick release valve should be mounted close to the brake so in case of any emergency, the air can be dumped out of the actuator instantly letting the spring apply the brake pushing the wedge downward. In order to make this functional the manual release screw must be removed. In order to release the brake caliper, air must be applied to the parking port and should be energized at all times while the brake is in regular operating mode.

The Maxi Pot brake actuators are also equipped with a manual release screw whereby the spring portion can be manually released. It is important that air be applied to the spring portion if possible, so that the threads do not become over-stressed when using the manual release screw. In some actuators the thread screw is not designed to release the actuators without the assistance of air.

In order to control the brake for normal operation, air lines must be connected to the service port and varying air pressure from 0 - 100 p.s.i. will then apply the brake. The brake torque will be absolutely proportional to the air pressure applied. In other words, if there is little air pressure the torque is small and with a lot of air entering the service port, the brake torque will proportionately increase. The lower nut located nearest the smallest end of this wedge must be loosened and the upper nut on the upper end of the wedge must be turned downward so that the rollers are spread farther apart and, therefore, reducing the clearance between the disc and the brake lining.

### **SPRING APPLIED CALIPER**

It is of extreme importance to keep the clearance between lining and disc at a minimum. The springs that extend become weaker and, therefore, the brake torque will go down proportionately. Keeping the clearance between shoe and lining to a minimum will provide the specified brake torque.

# INSTALLATION AND ADJUSTMENT INSTRUCTIONS FOR KOBELT DISC BRAKE CALIPERS

## BRAKE DISC INSTALLATION

The brake disc must be installed onto a rotating element that is machined flat and clean for the disc mounting surface. The rotating element should have bearings sufficient to carry the weight of the disc and also absorb the additional stress when the disc brake is applied. The bearings should also be of sufficient quality to make the shaft run through without wobbling. Any excess run-out (wobble) of the disc could cause premature lining wear and also cause the caliper lever arm bearings to wear out as well as wearing out the actuator prematurely. For special applications, some end float in the shaft can be tolerated.

NOTE: Consult Kobelt for maximum float in shaft bearings

It is important to remember that the brake disc itself must be installed onto the rotating element before installing the caliper. This will then allow proper alignment of the brake caliper to the disc. The disc mounting bolts used must be suitable to absorb the brake torque plus any shock load in the system. For high temperature disc applications, the holes for the mounting bolts must be machined oversized to allow the disc to expand and contract during operation.

## BOLT MOUNTING HOLE DIAMTER OVER-SIZING IN INCHES

Disc Bolt Circle inches	Maximum Disc Temperature, °F			
	400	500	600	700
10	0.013	0.016	0.020	0.023
15	0.020	0.024	0.029	0.034
20	0.026	0.033	0.039	0.046
25	0.033	0.041	0.049	0.057
30	0.039	0.049	0.059	0.068
35	0.046	0.057	0.068	0.080
40	0.052	0.065	0.078	0.091
45	0.059	0.073	0.088	0.102
50	0.065	0.081	0.098	0.114
55	0.072	0.089	0.107	0.125
60	0.078	0.097	0.117	0.137
65	0.085	0.106	0.127	0.148
70	0.091	0.114	0.137	0.159
75	0.098	0.122	0.147	0.171
80	0.104	0.130	0.156	0.182

All fasteners must be SAE grade 5 or better.

Since a brake disc is absorbing energy during operation, it will in this process, become hot and consequently expand. The hotter a brake disc becomes, the more it will expand. Depending on the type of material used, a disc may also shrink during initial start-up and could become considerably smaller depending on the maximum operating temperature. Therefore the spigot diameter between the male and female bore must be machined to such dimensions as to allow for the shrinkage of the disc. We would highly recommend that you contact Kobelt Manufacturing with all the operating criteria for assistance. The minimum clearance recommended is 0.5 mm depending on the working temperature and disc size.

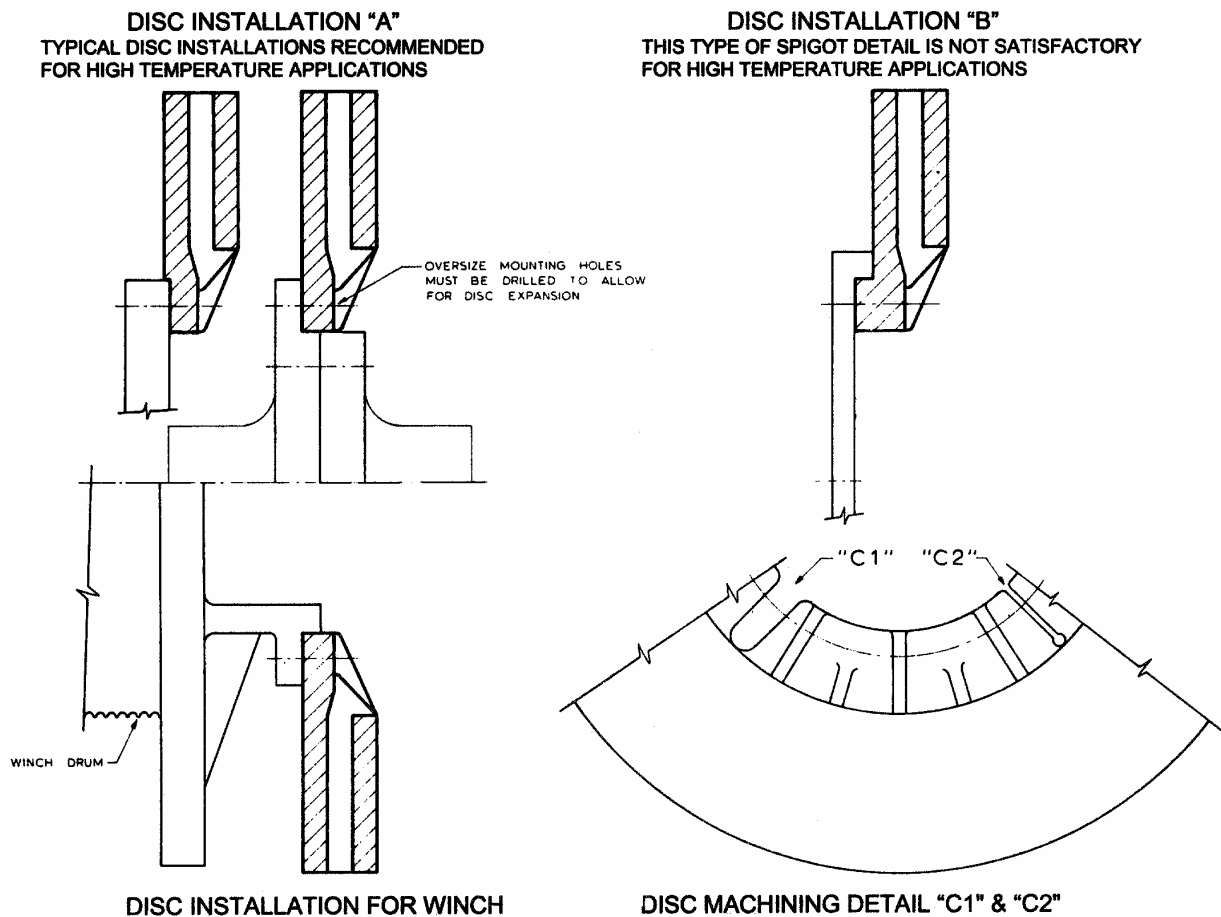

- Figure 1 -

The disc must never be machined with a male spigot for high temperature applications since such spigot (see Fig. 1 detail "B") will prevent the disc from expanding due to heat.

Under no circumstances should a disc be installed onto the rotating element by welding. This would result in immediate disc failure and also cause the caliper to be destroyed in a short period since the disc will be wobbly from being unable to expand and contract. The outer surface of the disc will become extremely wobbly and in the process, destroying the caliper.



The caliper brake unit should also be mounted as to allow for disc expansion without causing interference between the outer circumference of the disc and the inner caliper frame.

The heat transfer from the disc to the mounting flange is relatively low; therefore fitted bolts cannot be used. If the maximum operating temperature of the disc is known, the clearance allowance can easily be calculated after the bolt circle is established.

It is also important to obtain a fine grain disc casting material which should be machined to a fine finish (32 micro inches preferably). This will eliminate excessive lining wear.

**Important Notes:** All the clamping force and torque values of Kobelt Disc Brakes are generated in house, and mostly theoretical. Each actual test that took place was generated under ideal conditions. We would, therefore, recommend that a safety margin in selecting our disc brakes is important, since in most cases, field applications don't come close to perfect conditions and, therefore, should be calculated at a lower value.

On some equipment, it is not possible to burnish the Kobelt brake lining because of slow rotating or limited HP available. In cases like this the brake torque should be doubled in order to arrive at a satisfactory braking system.

In cold weather, iron becomes very brittle and it is, therefore, extremely important to warm up the disc gently without causing excessive thermal stresses in the disc. Or else, this could cause instant disc failure. Warming up the disc gently is of utmost importance. Once the disc is out of freezing condition it can be used normally as intended.

The Kobelt disc brakes are also equipped with shims that can be installed between the shoe and the shoe bearing to allow for various disc thicknesses. These shims are readily available at extra cost.

The Kobelt brake calipers and discs are installed in a wide range of environments. Some of them are running in very clean surroundings and some in absolutely dusty and dirty environments. Kobelt does provide brake calipers with grease fittings that must be greased in order to stop the calipers from seizing up. The frequency of lubrication depends largely on the environment. If Kobelt disc brake calipers are installed without grease fittings in a relatively dirty environment, it is highly recommended to take a good machinery oil and lubricate the pins with an oil can. This should be applied to all bearing and pin sections.

## **DISC BRAKE CALIPER INSTALLATION**

The foundation plate to support the brake caliper must be strong enough to withstand the maximum torque generated by the brake caliper. The foundation must also be flat and square to the brake disc. The caliper must be installed with the proper size bolts (grade 5 or better) as specified in our drawing and under no circumstances must there be a bolt missing. It is also important that these bolts be properly and evenly torqued. Failing to do so could cause the foot of the brake to fail. Ensure that the assembly fasteners are tightened before placing a brake caliper into operation. Again, loose bolts will cause the brake to fail and could cause severe injury to personnel.

With the 5000 series brakes, it is possible to undo the assembly bolts (or nuts) and raise the entire caliper arrangement away from the foot to allow installation of the mounting bolts into the brake foot. After the bolts are in place the brake can be re-assembled. The clearance between the brake and disc should be equally divided on both sides of the brake disc and the shoe should be parallel to the disc. The rugged design of Kobelt brake calipers allows for slight inaccuracy without adversely affecting the performance.

On the die-cast bronze 5000 series brake calipers, shims can be placed between the shoe bearing and the shoe to allow the calipers to be adapted to various sizes of disc thickness. The actuators themselves also have an adjustable clevis to allow for brake lining or disc thickness variations.

It is important that the clearance between the shoe and the disc be maintained at a minimum for fast response and also minimizes the air consumption in air applied calipers. The spring applied actuators are equipped with a single pipe port, with either 1/4" or 3/8" NPT thread, at the actuator piston housing.

The air applied actuators from the bronze die-cast series have two supply ports per actuator. These ports are common internally. Normally only one port is connected to the control circuit. Only in cases of extremely fast response will it become necessary to connect both ports externally.

All Kobelt calipers, during assembly, are pre-greased on the shoe pin and saddle pin with a high grade grease. In some applications where high cycling or dirty environment exists, it is recommended to have grease fittings installed on the lever. Every lever can be equipped with two grease fittings: one on the saddle pin and one on the shoe pin. It is highly recommended that these pins be regularly greased with a good quality grease. In applications where there are no grease fittings, it is recommended to lubricate the pins with a fairly heavy grade oil. There is an extra cost for installing the grease fittings.

When fabricating mounting foundations for either steering gear or disc brakes, it is extremely important that these items be installed on a flat and even surface. Failing to observe these instructions would cause a failure in the castings. When making a 'T' section foundation, the fabricator will install a flat piece of steel, as shown in Figure 1. However, when the items are welded together it will cause the mounting plate to be deformed, that is because when the welding cools, it will pull the mounting plate downward, making the top surface uneven and not acceptable for the installation of any Kobelt equipment, as in Figure 2. Even by placing mounting shims on the outside corners will not eliminate the problem, since the shims would have to be tapered to fit underneath, precisely, between the mounting foundation and the item to be installed. It is, therefore, recommended to make foundations as per Figure 3 and even in this case, welding can deform and twist the foundation plate if not done carefully. Please be careful to make this plate straight and square. Any fabrication selected must be strong enough to withstand any and all forces imposed by our steering gear or disc brake.

The mounting bolts must be of SAE grade 5'.

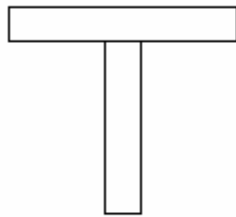

**FIGURE 1**

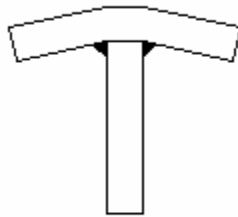

**FIGURE 2**

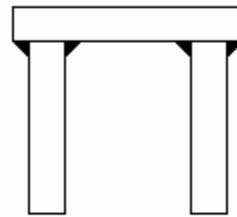
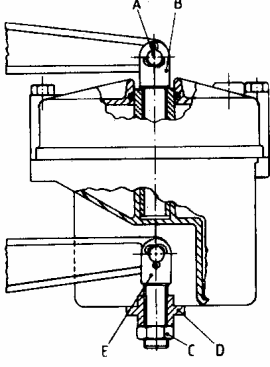
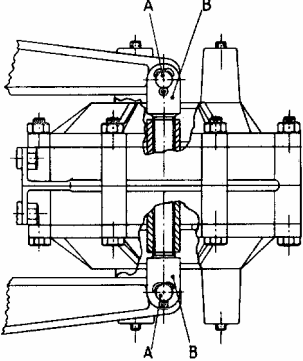

**FIGURE 3**

The contact area for the mounting screws or nuts should be half the bolt diameter. In other words, if the bolt is 1", the contact area of the bolt should be 1/2" and that would leave a contact area all around the bolt of 1/4". This will avoid the bolts sinking into the foot causing the bolts to become loose. This could come from heavy loads and vibrations. A locking mechanism for all bolts and nuts such as Loctite® is helpful to ensure a secure joint.

## CLEARANCE ADJUSTMENT

*Before making any adjustment ensure that the brake is released*

	<p><b>SPRING APPLIED ACTUATOR</b></p> <p>The clearance can be adjusted by removing pin "A" and then turning clevis "B". It can further be adjusted by loosening jam nut "C", then removing bolts in bracket "D" and rotating same.</p>		<p><b>FLUID APPLIED ACTUATOR</b></p> <p>Remove both pins "A" and turn both clevises an equal amount. Turn counter clockwise to decrease clearance and clockwise to increase.</p>
---	--	--	--

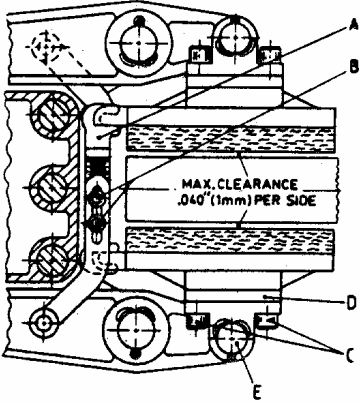
	<p><b>BALANCING LINK ADJUSTMENT</b></p> <p>Most calipers are equipped with balancing links to ensure even lining wear. To adjust, loosen screws "B" and adjust link "A" to align the shoe parallel with the disc.</p> <p><b>SHIM KITS</b></p> <p>In order to adapt a caliper for a thinner disc, shim kits are available for use. These shims "D" fit between the brake shoe and the bearing. See products sheets for ordering information.</p> <p><b>LINING REPLACEMENT</b></p> <p>It is important to replace the lining before the rivets make contact with the disc. By removing screws "C" or pin "E", the shoes can be taken off from the caliper assembly. Drill out the rivets and install new lining with the proper rivets. When re-installing shoes into the caliper assembly, be sure to re-engage the balancing link "A".</p>
---	---

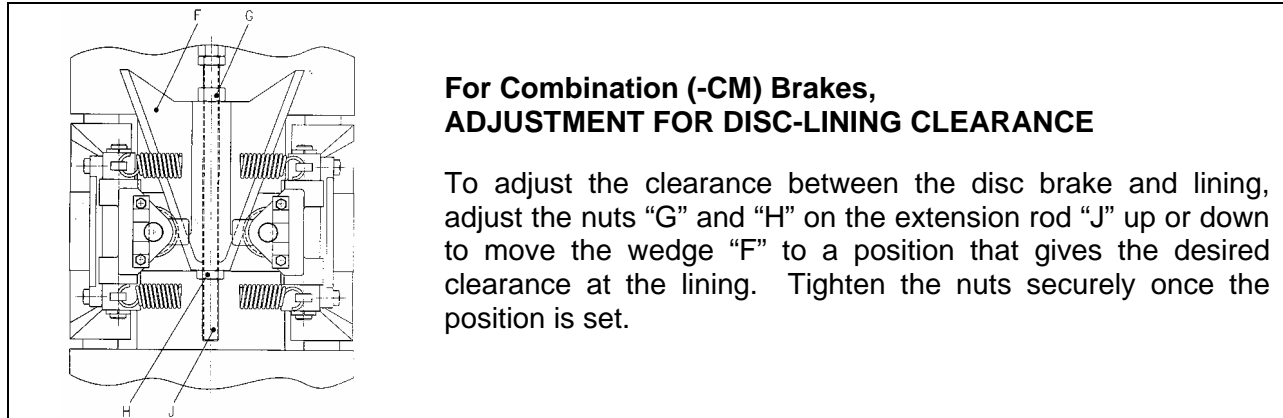

**For Combination (-CM) Brakes,  
ADJUSTMENT FOR DISC-LINING CLEARANCE**

To adjust the clearance between the disc brake and lining, adjust the nuts “G” and “H” on the extension rod “J” up or down to move the wedge “F” to a position that gives the desired clearance at the lining. Tighten the nuts securely once the position is set.

**INSTALLING DISC BRAKE ON A DRILL RIG DRAW WORKS**

For many years the industry used drum brakes with a mechanical linkage to the driller platform. The movement of the lever was transmitted to the band brake. In other words, any slight mechanical movement of the driller lever was an instant response at the band brake.

When installing a disc brake on a drill rig, the power is transmitted via pneumatic air lines and valves. For many years we have been trying to teach the oil industry to use generous air lines. Our recommendation for a single disc requires a 3/4” supply line from the tank to the booster relay model 3329, and from the booster valve to the brake. The air lines from and to the driller valve 2588 should be 3/8” ID. This will give an immediate response to the brake calipers. If there is a delay in brake application the operator might have pushed the brake handle too far. Consequently, once the air reaches the brake caliper, it will be too much. So the operator will have to pull the handle back. All day long he will be searching for the right brake torque. However, if it happens instantly, he will feel much more secure and will enjoy running the rig with confidence.

**TWIN BRAKE CALIPER INSTALLATION**

It is recommended to have a 1” ID line from the tank to the 3329 relay valves and a 3/4” ID line from the brake relays to the brake caliper. It is also recommended to have a pneumatic interlock between clutch and brake. A crown saver valve can also be installed to avoid overshooting at the top.

There are many ways that we can provide pneumatic circuitry and valves to improve the operation of a drill rig. Please contact Kobelt for various options.

What really makes the drill rig easy to operate is with Kobelt disc brakes on the main drum whereby the pressure can be set to allow the drill to proceed at a constant rate. Many operators have long discovered this advantage.

For the emergency line, a 3 way valve of relatively small flow can be provided. A quick release valve must be installed near the brake actuator to dump the air rapidly in case of an emergency.

## **AIR SUPPLY AND TREATMENT OF DRAW WORKS DISC BRAKES**

It is of extreme importance that air compressors and storage tanks provide sufficient air during the operation of the brakes and clutches. There must not be any shortage of supply air. It is also of extreme importance that all the air lines between the tanks, control valves and brake actuators are of a generous size. An operator will lose confidence in the rig if the response between control handle and brake response is not instant. Actuators and control valves equipped with “U” cups and “O” rings require lubrication in order to provide long service life. “O” ring and “U” cups will become sticky and show wear if not lubricated properly. Diaphragm type actuators do not require lubrication. However, it is recommended that the control valve should have a lubricant in order to make it respond accurately.

The main supply line to the control and brake system should be equipped with a filter and regulator. The filter's function is to remove moisture and dirt in the system and the regulator will provide a constant air pressure to the control system. It is therefore, important that the compressor pressure be set higher than the air pressure regulator. The oil that is required for the lubricator should be of a hydraulic type with a viscosity of 10 to 32. Heavy oils are not a good solution for lubricators. If the draw works is operating in a cold environment, it is recommended to have an air dryer in the system to remove all moisture. In some cases, in extreme cold locations, it may be necessary to add a lubricator large enough to handle all the air flow. This lubricator should be equipped with a metal bowl. This lubricator can be filled with methyl hydrate (wood alcohol). The wood alcohol must, however, be used sparingly since it is not friendly to most synthetic rubber.

## **INITIAL BRAKE START UP**

In order to achieve maximum brake torque, it is of the utmost importance that the brake lining is sufficiently burnished. This can only be accomplished if the brake is applied on a relatively low pressure with the engine or motor driving the brake disc. This should be done approximately three times. The maximum disc temperature that should be achieved is approximately 500°F and each run should take approximately 10-15 minutes. A normal brake lining will provide a coefficient of friction of 0.45 at 200°F and can go as high as 0.6 at approximately 400-450°F.

If the lining is not properly burnished, a coefficient of friction as low as 0.3 is all that can be obtained. Extreme care, however, must be taken not to overheat the disc during the process. If the brake system is running in an environment where maximum brake torque is required (see note), burnishing has to be done all over again after a lining replacement. On water cooled discs it is extremely difficult to burnish the lining unless only a limited amount of water is fed into the disc during the burnishing operation. Again, extra care must be taken not to overheat the disc.

Note: To calculate brake torque, use the following formula:

**Brake torque = clamping force x coefficient of friction x acting radius of disc**

## **CHECK LIST: BEFORE STARTING DISC BRAKES**

- (1) Ensure that all bolts are of good quality and properly installed.
- (2) Make sure that brake lining does not make contact with the disc when the brake is released. Also ensure the brake is reasonably square to the disc.
- (3) Brake levers movement must not be obstructed and sufficient room should be allowed for the actuator rod to come out completely without any interference.
- (4) Check the brake disc surface for foreign matter and grease. Remove all contamination from the disc with cleaning solvent. If the disc was damaged during installation with nicks or welding marks, remove the defects before putting into service.
- (5) Check the source of fluid supplied that it complies with the specified pressure range and that it is properly interlocked with other machinery such as clutches, electric motors, etc.
- (6) Check that all bolts are tight and cotter pins are in place.

## **MAINTENANCE**

Over the years, it has been proven that very little will go wrong with the Kobelt disc brake calipers and discs. However it is important that periodic inspection and maintenance should be carried out. The lining must be replaced before the shoe lining bolts or rivets start making contact with the brake disc. Moving joints are to be adequately lubricated for smooth and safe operation.

### **ACTUATOR MAINTENANCE**

Kobelt actuators require very little maintenance. However, due to normal wear and tear on the parts, regular inspection and maintenance should still be carried out

#### **AIR (FLUID) APPLIED ACTUATORS**

In most cases these actuators are diaphragm operated and consist of two opposite spring-returned diaphragms with an "O" ring between the centre housing. Should any of the diaphragms or seal failure occur, remove actuator, dismantle same, clean and re-install new diaphragm or seal and re-assemble actuator.

Operating temperature of fluid applied actuator is -40°C (-40°F) to 120°C (248°F).

#### **SPRING APPLIED ACTUATORS**

If maintenance is required on the spring applied actuator, it must first be removed from the brake assembly. In order to remove the actuator, pressure must be applied to the actuator to release the brake, or use the manual release screw if available. After removal it must be retained in a press strong enough to retain the spring tension of the actuator. CAUTION: It is important that this holding device maintains the actuator in a position square to the press. The bolts holding both housings can now be removed and the pressure of the press can be slowly released thus allowing the housings to separate. Clean actuator, replace seals, inspect springs and change parts if necessary. Lubricate all moving parts, re-assemble and re-install actuator in reverse order.

Operating temperature of spring applied actuator is -40°C (-40°F) to 120°C (248°F)

Disc brake calipers equipped with spring applied actuators must have a lubricator in the control air system using light hydraulic oil as lubricant. This is to prevent premature seal wear and stickiness.



## **SPRING APPLIED ACTUATORS WITH MANUAL RELEASE SCREWS**

All Kobelt spring applied actuators can be supplied with manual release screws. This release screw serves to release the brake upon failure of the fluid pressure. It is very important that the fluid supply line is open to tank or atmosphere when winding the release screw inward, since the piston cavity requires a fluid supply source when doing this. This holds especially true in hydraulic systems where a vacuum plus the spring tension is generated.

## **BRAKE SHOE CLEARANCE ADJUSTMENT FOR SPRING APPLIED ACTUATORS**

On the spring applied caliper, it is extremely important that the proper clearance be maintained between the shoe and disc. On the manual adjust actuator, remove the clevis pin and the clevis and manually rotate so that an optimum clearance between the disc and shoe can be obtained. When a lining is replaced it will be necessary to turn the clevis inward to allow for the extra thickness of a new lining. During normal use, our automatic adjust spring applied actuators will automatically adjust for the wear on the brake lining. When new lining is installed, the clevis pin must be removed from the actuator rod and the clevis turned, allowing the actuator rod to be pushed in completely for the extra lining thickness. Re-insert the clevis pin after the adjustment.

For optimum performance, it is essential that the clearance between the shoes and disc is kept at a minimum without inducing drag. The clearance should not exceed 0.010" (0.25 mm) for each side. This will allow for fast response as well as the minimum fluid consumption. The smaller the clearance is kept between the brake shoe and disc, the higher the maximum torque will be.

Disc brake calipers equipped with spring applied actuators operated with air pressure must have a lubricator in the system and the lubricant must be filled with a light hydraulic oil. This is to prevent premature seal wear and stickiness.

## **OPEN SHOE TYPE BRAKE CALIPERS (5000 SERIES)**

On these calipers the brake shoes are attached with pins to the brake lever. These pins must be removed in order to detach the brake shoe from the caliper. New lining can be installed and the brake re-assembled. It is important that the balancing link is connected to the back of the brake shoe.

## **UNEQUAL LINING WEAR**

Kobelt Manufacturing has established a formula for placing the shoe pin on our open shoe disc brake calipers in a location where there is an equal pressure-velocity balance. Lining wear, however, is mainly determined by disc temperature and several other factors. In order to provide relatively equal lining wear a balancing link is developed that will control the lining wear from the ID to the OD of the lining. However, in some cases when the caliper is not centered, extreme stresses are put on the balancing link and in fact, will break or bend it. The balancing link is only intended to take up 3% of the

unequal pressure, which is, in most cases, more than sufficient to keep the brake lining wear even from inside to outside. However, lining wear is very much affected by disc temperature and it is quite normal for the i.d. of the disc to not get as hot as the o.d. of the disc. Therefore lining wear becomes more rapid. If, however, a brake is operating under cool conditions, the lining should be balanced from i.d. to o.d. Since every installation is different and various temperature profiles in disc exist, it is still very difficult to predict precisely what is going to happen to the lining wear.

The diagram below shows a typical Kobelt air applied brake caliper with all the technical advances that we incorporate in our products. You will notice the double acting diaphragm actuator which uses two diaphragms and the spring return is of extreme compact design and offers infinite accuracy as far as brake torque is concerned. The saddle balancing links provide equal lining wear on both shoes since the levers are mechanically interconnected to allow both shoes to move equally. This also provides good balance with actuators that are not centered such as our spring applied actuator.

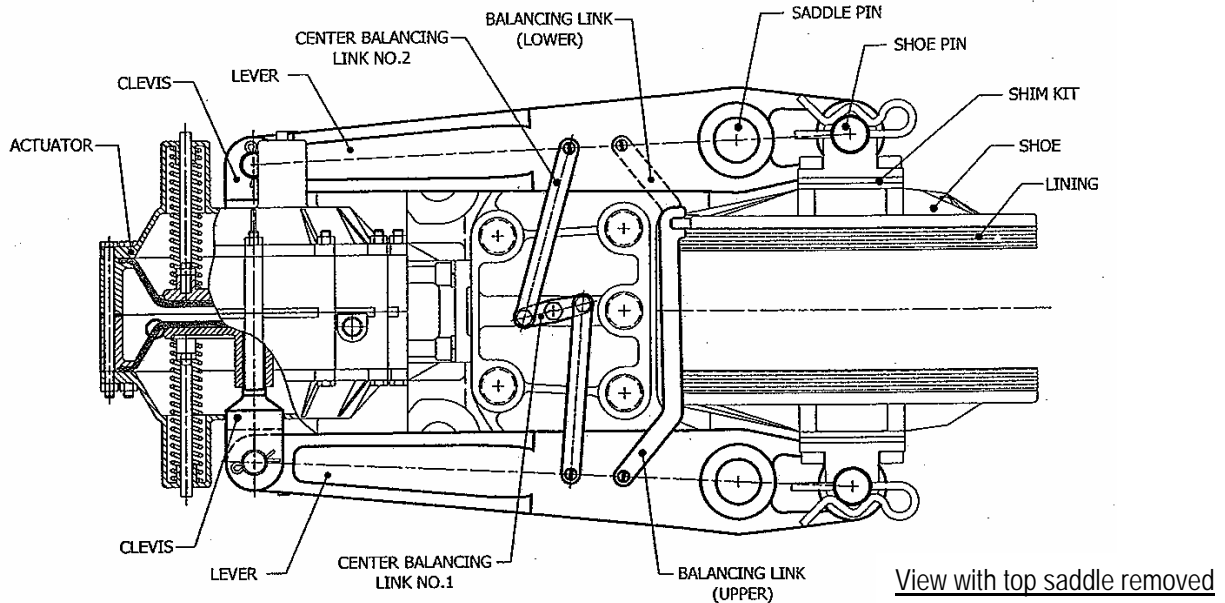

Kobelt also developed a balancing link to provide equal wear from the front of the shoe to the back of the shoe since this link causes the shoe to move at the same rate as the pin against the disc providing equal lining wear across the shoe.

All of these items were developed by Kobelt and have patents issued for them. You can see that Kobelt spends a tremendous amount of effort to provide a professional product for the industry.

If our instructions are followed during installation and maintenance, the performance of our products will prove to be most satisfactory. There is nothing like a satisfied customer.