

Mechanical Transplanter Company

Parts Book for Model 580

10	Inside Chain Guard	521	Roll Pin
11	32 Steel Chain for Direct Drive - 63 Links	522	Clip Pin
12	Direct Drive Tire & Rim	529WP	Wide Wheel Scraper Plastic Only
14	Outside Chain Guard	535	550 & 580 Wheel Scraper Extension
18	Unit Chain Tightener Bracket	580PF	580 Planter Frame
19	Short Chain Tightener Pipe Bearing	582	580 Pocket Guide
22	Unit Chain Tightener Arm	584L	Left Plant Box Stand
23	Washer to Hold Spring	584R	Right Plant Box Stand
24	Long Chain Tightener Pipe Bearing	585	Pocket Disc for Model 580
30	Wheel Chain Tightener Pipe Bearing	586	Extension Plate
31	Main Frame of Rear Half	637	Fiberglass Seat Bracket
32	Wheel Chain Tightener Spring	639AHDD	Direct Drive Packing Wheel Hub
33	Wheel Chain Tightener Arm	639WAL	Wide Adj. Packing Wheel less Hub
35	Lift Chain	640	Wide Plant Box - 16" (each)
38	Wheel Hub with Sprocket	650	Foot Rest for Models SU-3, 500, 525, 550
39	Main Frame of Front Half	715	3/8" U-Bolt with Nut
40	Left Clamp less U-Bolt	726	L Seat Bracket (after 1983)
41	32 Steel Chain for Direct Drive - 34 Links	727	1/2" U-Bolt for Seat Bracket
42	Right Clamp less U-Bolt	740	7/8" U-Bolt with Nuts
43	Bushing for Clamp	1000AL	Axle for Left Side of Model 1000
44	Chain Lift Plate	1000AR	Axle for Right Side of Model 1000
48	Right Direct Drive Clamp for 4x4 or 4x7	1907	Pocket Wire
49	Left Direct Drive Clamp for 4x4 or 4x7	1908	Double Neoprene Gripper
313	1/4 X 1-1/2" Cotter Pin	1914-580	Pocket Frame for Model 580
328	3/4" Flange Block	1915-580	Pocket Complete for Model 580
348DD	3/4" Lower Shaft for Direct Drive	4728	Jackshaft Pipe Spacer
373	Chain Tightener Spring	4729	Direct Drive Shear Pin
376S	Tension Spring	FC167	5/16 x 2" Carriage Bolt
381	7 Tooth Spacing Sprocket	FC205	3/8 x 3/4" Carriage Bolt
381I	7 Tooth Idler Sprocket	FC209	3/8 x 1" Carriage Bolt
383	9 Tooth Spacing Sprocket	FC213	3/8 x 1-1/2" Carriage Bolt
386	Direct Drive Drawbar Shaft	FC335	1/2 x 1-1/2" Carriage Bolt
386P	Shaft Clip Pin	FH227	3/8 x 3-1/4" Hex Head Cap Screw
395-580	Model 580 Shoe, 10" Deep, 2-3/4" Wide	FH335	1/2 x 1-1/2" Hex Head Cap Screw
416	3/4" Oilite Bearing	FMB500	7/8" Machinery Bushing
434	7/8" Oilite Wheel Bearing	FNH150	5/16" Finished Hex Nut
436B	L-Bolts for Pocket Guides	FNH300	1/2" Finished Hex Nut
462	11 Tooth Wheel Sprocket	FW300	1/2" U.S.S. Flat Washer

Mechanical Transplanter Company, LLC
1150 Central Avenue * Holland, MI 49423
Phone: 616-396-8738 * Fax: 616-396-3619

website: www.mechanicaltransplanter.com
e-mail: mtc@mechanicaltransplanter.com

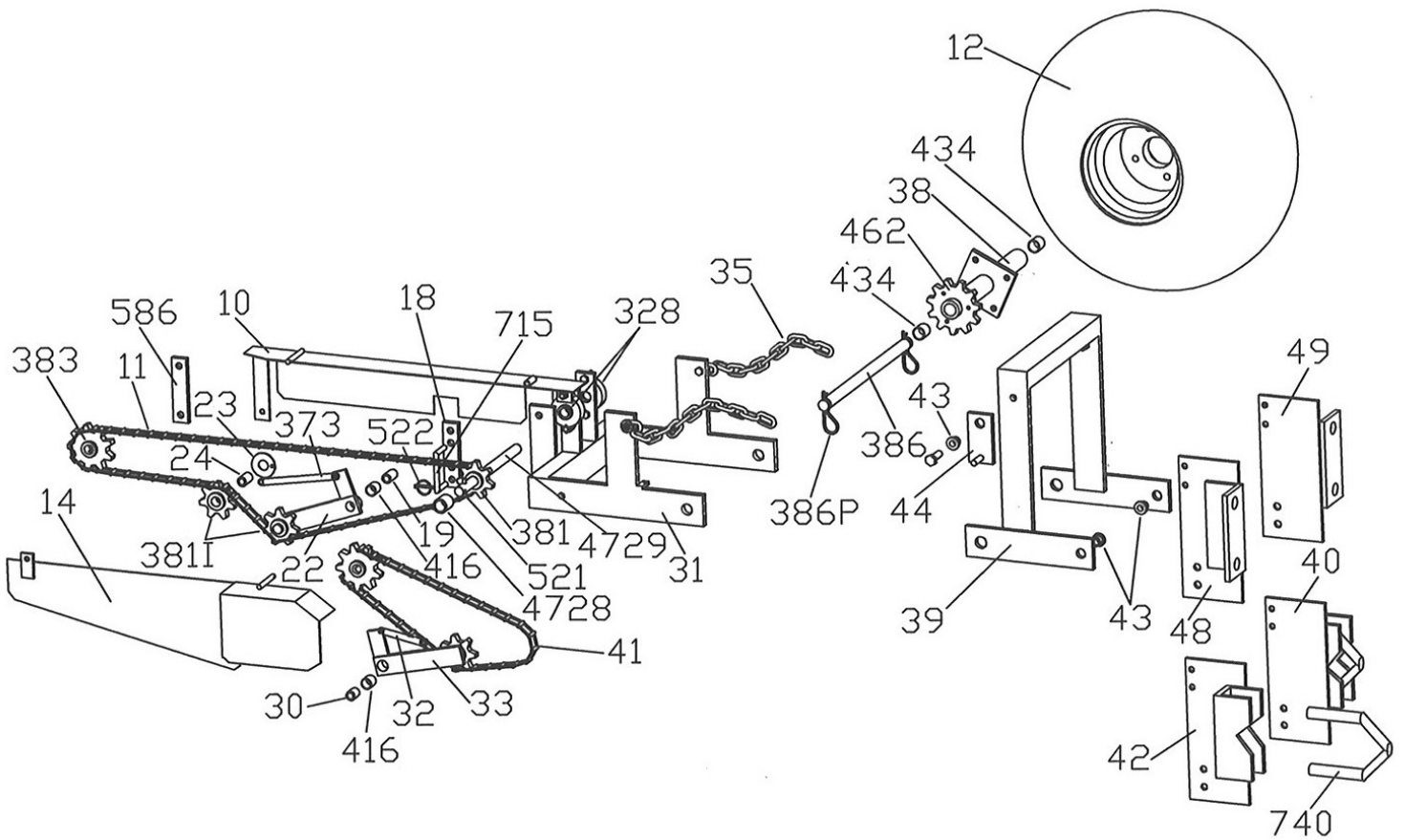
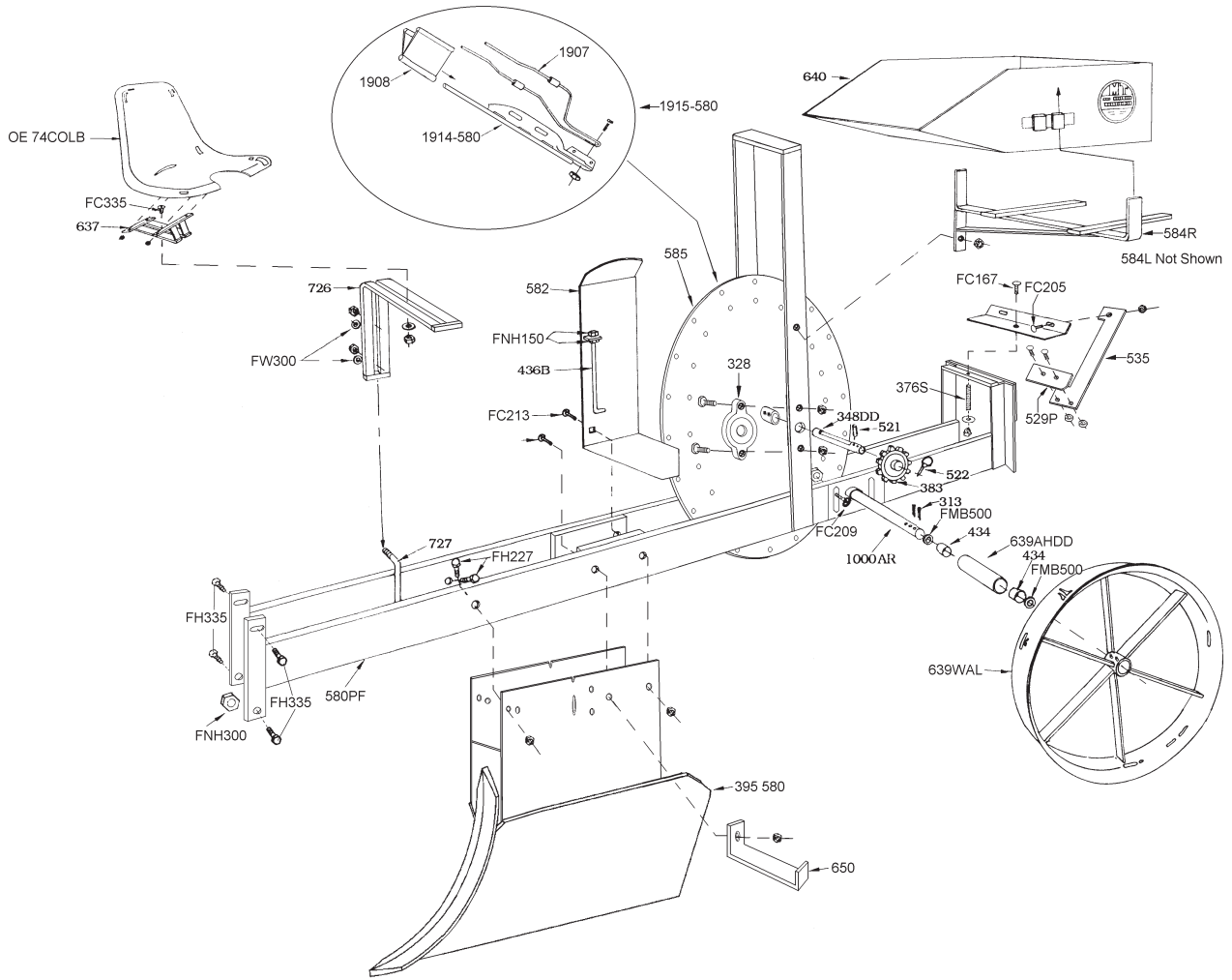

General Operating and Maintenance Instructions

REGULATING PLANT SETTING DEPTH: All new operators should take care to see that the plants are placed well down in the pockets so that the plant is held firmly. The depth for setting of plants can be regulated by the distance that root is extended out of the pocket.

CHAIN UNITS: Make sure the upper conveyor sprocket isn't over tightened, causing the chain to become stretched between the upper and lower sprockets. This will put unnecessary friction on the unit perhaps causing the packing wheels to slip on rear drive units. Tighten the wing nuts equally so the chain runs level.

ADJUSTING AND SETTING SHOE: Whenever any adjustment is made, be sure to get the shoe directly square and straight in front of the opening of the wheels so the pockets travel through the middle of the shoe. The shoe can be adjusted ahead or back with brace fastened on the right side of the unit frame. In loose, dry soil, the shoe should be set back and closer to the packing wheels or ahead and away from the packing wheels in heavy, wet soil. **KEEP SHOE CLEAN** at all times. Don't allow soil to build up on sides or trash in front of the shoe as this will cause the shoe to make a wider furrow, and the packing wheels will be unable to bring the soil back in around the plants. It may be necessary to add a coulter to the unit to cut this trash if it's a problem. Also, make sure the soil is worked deeper than the penetrating depth of the shoe. Hard pan soil under the shoe will cause the unit to ride up and lose its traction.

CAUTION: PULL UNIT FORWARD ONLY. Backing up causes damage to pockets and can plug shoe up with dirt.

ADJUSTING WATER VALVE: The water valve has a ball check tripped from below. The reservoir allows water supply to build up between plants. There is a float in the top of this reservoir to automatically close when filled. This air allows water to drop quickly as it is tripped by each plant. The **AMOUNT OF WATER IS CONTROLLED BY SIMPLY ADJUSTING THE BALL VALVE** to regulate the amount of water you want by each plant. Be careful, too much water in dry fluffy soil can cause the plant to float to the top of the furrow. The rocker arm and cam which is bolted onto frame of planter for tripping valve has a slot in it for adjusting timing of water. When rocker is moved up, the water will trip sooner. When moved down, it will trip later.

AIR VALVE FLOAT: Once each season the cap at the top of valve should be removed to check condition of the air valve float. This small ball can be floated to the top with water or pulled out with a piece of wire for inspection. This float is the critical to the operation of this valve. It and the rubber at the top should be replaced if not in good condition.

INSTALLING NEW BOTTOM CHECK BALL: Remove the valve from planter. Then remove bottom spout and the adjustable slide on trip rod. Unscrew plastic seat from tee. New check ball with stem can then be easily inserted. Do not tighten nut on stem completely, but leave enough play for the ball to wobble, allowing it to self center itself in the plastic seat.

MAKE SURE THE WATER IS DRAINED OUT OF THE VALVE AT THE END OF EACH SEASON OR IT WILL FREEZE AND DESTROY THE INSIDE

Float Wheel Direct Drive Operating Instructions

Run the float wheel with only 4 to 5 pounds of pressure during operation. Plant spacing can be changed slightly by increasing or decreasing the tire pressure.

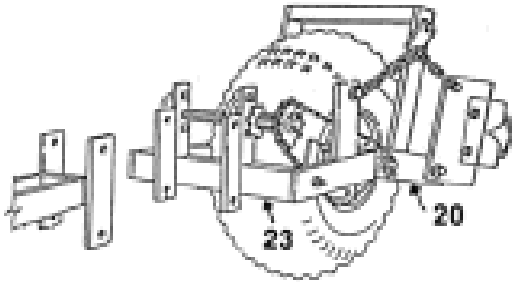

Be sure to run the planting unit level with the soil. Then check that the toolbar is in the middle of the hitch so that frame members #23 and #20 are **STRAIGHT IN LINE**. Do not run the front frame (#20) up as this will take weight off from the wheel. For toolbars that are not adjustable for height you may have to use the lower holes on the front clamp plates to get the frame to run straight.

The hitch and wheel will float freely and sense uneven soil conditions if set properly. **DO NOT TIGHTEN LIFT CHAINS.** They must be loose when planting. If you can not lift the units high enough, raise the lower arms on your tractor by cranking them up. Do not tighten the chains.

For some unusual spacings, an extra link or two may be added to the drive chains.

If more weight is needed on the back of the unit for proper packing, use the optional OE-73 weight bracket.

580 Spacing Chart

MODEL 580 SPACING CHART
12- #1915 Pockets on a disc

Sprocket on outside of Jackshaft	Sprocket on Inside of Jackshaft	Number of teeth on Sprocket by Disc				
		7	8	9	10	11
11	9		5-1/2"	6"	7"	
11	8			7-1/2"	8-1/2"	
11	7			8-1/2"	9"	10"

Safety Precautions

1. Make sure tractor is stopped and in neutral with the transplanter lowered to the ground before getting on and off the unit.
2. No operator is allowed to be on the unit as it is raised and lowered.
3. No operator is allowed on the transplanter as it is transported to or from the field.
4. All operators must be seated before movement begins and remain seated until the transplanter is completely stopped.
5. Never leave the transplanter in the raised position.
6. Keep all shields and guards in place when operating the transplanter.
7. Never attempt repairs or maintenance while the transplanter is in motion.
8. Never put the tractor in reverse while the transplanter is on the ground.
9. Follow all safety instructions supplied by the tractor manufacturer to which the transplanter is mounted.

MACHINE IMPROVEMENTS

MECHANICAL TRANSPLANTER CO. IS ALWAYS STRIVING TO MAKE IMPROVEMENTS ON THEIR LINE OF EQUIPMENT. MECHANICAL TRANSPLANTER CO. RESERVES THE RIGHT TO MAKE IMPROVEMENTS AND CHANGES AT ANY TIME WITHOUT INCURRING OBLIGATIONS TO MAKE SUCH CHANGES OR ADDITIONS TO EQUIPMENT PREVIOUSLY SOLD.

Limited Warranty

Mechanical Transplanter Company warrants each item of new equipment manufactured by Mechanical to be free from defects in material and workmanship under normal use and service.

The obligation of Mechanical Transplanter Company under this LIMITED WARRANTY is limited to repairing or replacing as Mechanical may elect, and any parts that prove, in Mechanical's judgment, to be defective in material and workmanship within the first season's use or 45 consecutive days after initially placing equipment in operation, whichever occurs first. Any outside work or alterations without Mechanical's written approval will render the LIMITED WARRANTY void.

Mechanical's obligation specifically excludes any liability for consequential damages, such as loss of profits, delays, expenses, damage to goods or property used in connection with or processed in or by the product sold, or damage to the product sold from whatsoever cause, whether or not such loss is due to negligence of selling dealer of Mechanical Transplanter Company.

This limited warranty shall not apply to any item or machine which shall have been operated in a manner not recommended by the Company nor which shall have been repaired, altered, misused, damaged in an accident, neglected, tampered with or used in any way which in the Company's opinion adversely affects its performance and results.

No person is authorized to give any other warranties or to assume any other liability on behalf of Mechanical Transplanter Company, unless made in writing by Mechanical.

This limited warranty covers repair or replacement of Mechanical Transplanter Co. equipment only and does not cover crop loss, downtime, labor, damage to other equipment, etc.

This limited warranty does not apply to exterior finishes, tires, chain links, bearings, or any other items sold by Mechanical Transplanter Co., but warranted by the original manufacturer except to the extent of their individual manufacturer's warranty.

THIS LIMITED WARRANTY IS IN LIEU OF ALL OTHER WARRANTIES, EXPRESSED OR IMPLIED. WARRANTIES OF MERCHANTABILITY AND FITNESS FOR PARTICULAR PURPOSE ARE EXCLUDED, AS ARE ALL OTHER REPRESENTATIONS TO THE USER-PURCHASER, AND ALL OTHER OBLIGATIONS OR LIABILITIES, INCLUDING LIABILITY FOR INCIDENTAL AND CONSEQUENTIAL DAMAGES, ON THE PART OF MECHANICAL OR THE SELLER.

Mechanical Transplanter Company, LLC
1150 Central Avenue * Holland, Michigan 49423
Phone: 616-396-8738 * Fax: 616-396-3619

www.mechanicaltransplanter.com mtc@mechanicaltransplanter.com