

# **MODEL 5000W**

## **Assembly and Operators Manual**



**Mechanical Transplanter Company**  
1150 Central Avenue Holland, MI 49423-5230  
Toll Free: 800-757-5268 \* Phone: 616-396-8738  
Fax: 616-396-3619

website: [www.mechanicaltransplanter.com](http://www.mechanicaltransplanter.com)  
e-mail: [mtc@mechanicaltransplanter.com](mailto:mtc@mechanicaltransplanter.com)



# Table of Contents

1. Assembly.....	2
2. Carrousel Tray Holder.....	6
3. Operation and Timing.....	10
4. Service.....	13
5. Gauge Wheel Drive Spacing Chart.....	13
6. Troubleshooting .....	14

# Assembly Instructions

1. Mark the center of the toolbar.
2. Mark your row centers clearly from the center of toolbar.
3. Fasten the units to the toolbar at the row centers using the proper 5/8" bolts.

4 x 7 Toolbar - 5/8 x 9-1/2                      w/Row Knocker - 5/8 x 13  
4 x 4 Toolbar - 5/8 x 6-1/2

*If using our OE 66 Row Knocker, follow the special instruction sheet enclosed with Row Knocker.*

a.

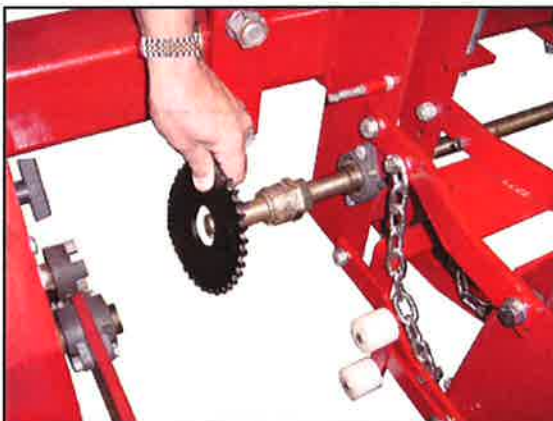

b.

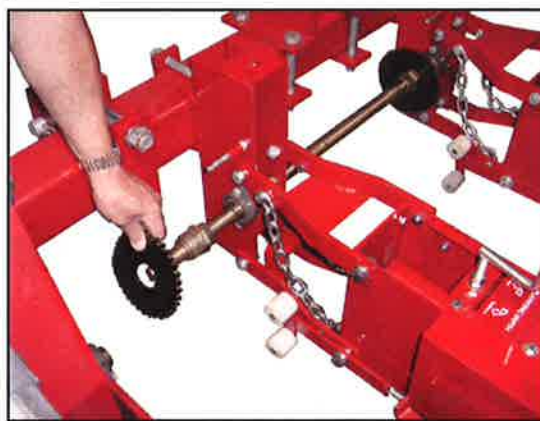

4. Loosen each flange block on the toolbar clamps. Do not take them off, but make sure the flange blocks have some play. Back off the set screws in the flange blocks as well.
5. Slide the 1" stainless steel shaft through the 1st unit only (fig a). Add a 35 tooth sprocket and transtorque to the shaft on the drive side of the unit. Do not tighten the sprocket on the transtorque.

**NOTE:** *For those setting dark tobacco and using wide plant spacings, a 22 tooth sprocket will be included for the 1" shaft and a 12 tooth sprocket for the gearbox.*

6. Continue to slide the stainless shaft through the 2nd unit and add another 35 tooth sprocket and transtorque on the shaft (fig b).

## **DO NOT TIGHTEN THE SHAFT YET!**

7. Attach the gauge wheel drive system to the toolbar (fig c).

4 x 4 Toolbar: 5/8 x 6-1/2 Bolts  
4 x 7 Toolbar: 5/8 x 9-1/2 Bolts

c.



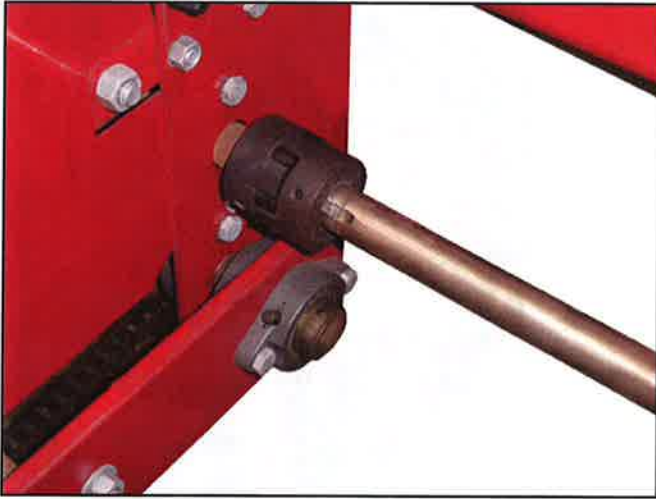

8. Fasten the stainless drive shaft to the gauge wheel drive system using the "Love-Joy" coupler.
9. The drive shaft can now be secured in place by tightening the bolts holding the flange block and the set screws securing the 1" steel shaft.

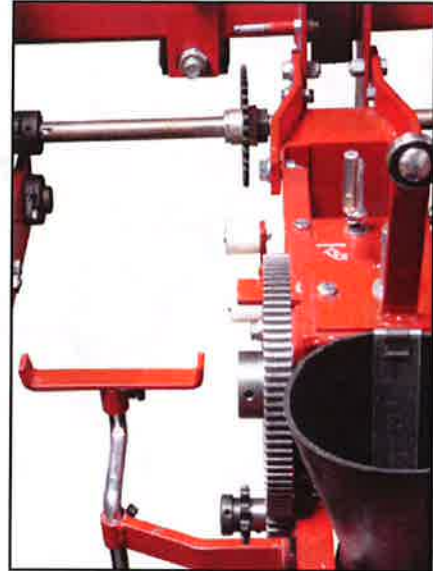

10. Align the 35 tooth sprocket on the transtorque with the 10 tooth sprocket on the transplanter. Tighten by turning the hex side of the transtorque. An instruction card is enclosed for tightening the transtorque.



11. Install the main transplanter drive chain under the front roller and over the rear roller of the chain tightener



12. If the guard over the large spur gear was removed to install the chain, place it back on before continuing.

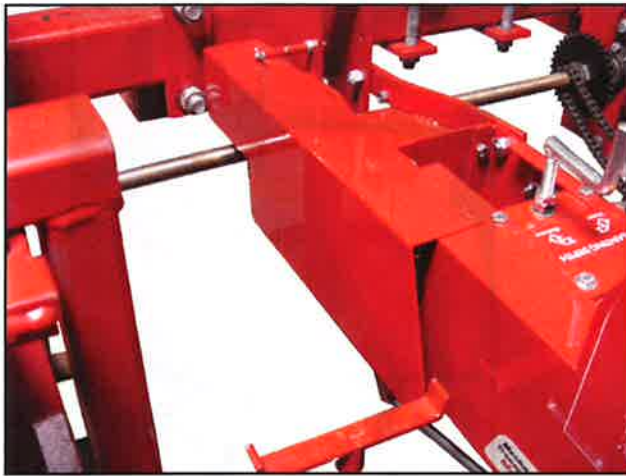

13. Place the 1" long red spacer over the pin located by the toolbar clamp. Slide the chain guard over this pin. Secure with small clip found in the plastic bag located in box with the seat bracket.



14. Install the windshield on the back of the transplanter. Use one 5/16 x 1/2" bolt with the small washer into the threaded hole by the large drop tube.



15. Adjust the footrests to desired position with the two square head set screws.



16. Place the six tube carousel feeder onto the vertical shaft of the gearbox. Align the key in the tubing with the keyway in the vertical shaft. Tighten using the square head set screw.

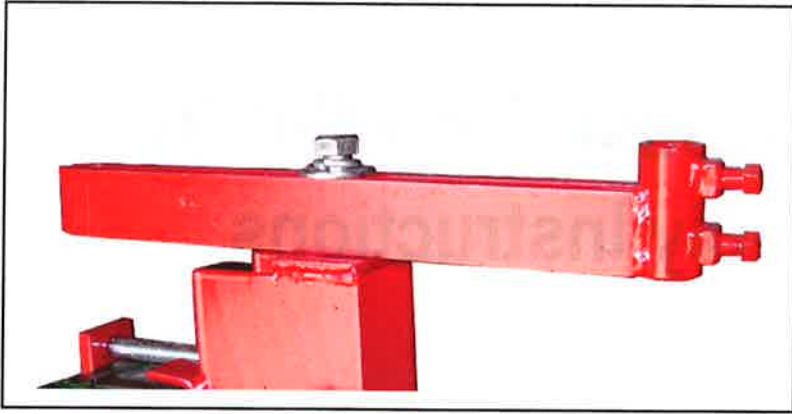

17. Place the long seat bracket on top of the toolbar clamp. Secure the seat brace using a  $3/4 \times 3-1/2$  bolt with a flat washer first and then a lock washer.
18. Follow the instructions for either the fiberglass seat or the cushion seat below.

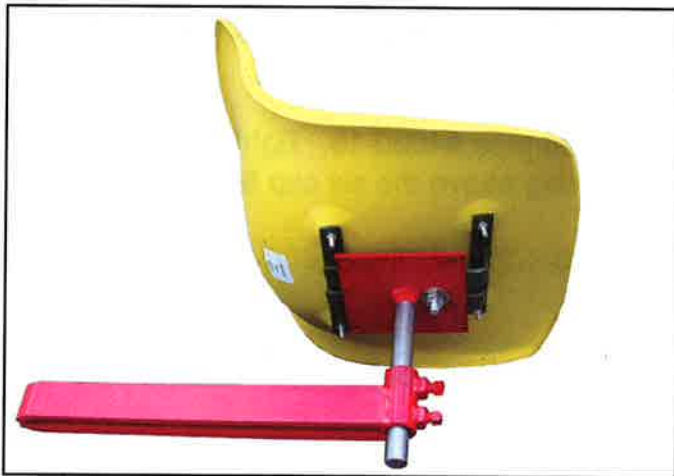

### Fiberglass Seat

- a. Attach the green fiberglass seat bracket to the bottom of the fiberglass seat and secure with  $4-1/4$ " nuts.
- b. Use a  $1/2 \times 1-1/2$  Carriage bolt through the green seat bracket and attach it to the large hole in the square red bracket.
- c. Slide the round rod of the seat bracket into the tubing of the seat brace.
- d. Secure by tightening the square head set screws when the proper height is achieved.



### Cushion Seat

- a. Attach the red square seat bracket directly to the bottom of the cushion seat. Use four  $5/16 \times 1/2$ " bolts.
- b. Slide the round rod of the seat bracket into the tubing of the seat brace.
- c. Secure by tightening the square head set screws when the proper height is achieved.

# Model 5600 Carrousel Tray Holder Assembly Instructions

1. Place the #5533 carrousel base onto the #5504 back plate of the Model 5000W. Secure to bottom with 3/8" hex nuts. Fasten at top with (#FH431) 5/8" x 2" hex bolt with lock washer and hex nut.
2. Place the #5150 pipe holder on the #5533 carrousel base. Secure and adjust using the (#FH443) 5/8" x 3-1/2" hex bolt. Use a lock washer and flat washer with the hex bolt.
3. Slip the set collar #6600-05 over the long pipe (#4600-18). Slide the long pipe into the pipe holder #5150 until it can be seen on the bottom. Tighten the square head screw to keep the pipe in place. The collar may be adjusted later to the proper height needed for each operator.
4. Slide the tray frame #4600-07, with bent edges up, onto pipe #4600-18. Tighten the two 3/8" set screws so the bottom of the tray frame is resting above the six cup feeder head.
5. Place the #4600-19 disc on the long pipe. Measure 26-1/2" from the #4600-07 tray frame to the round disc. Tighten the 3/8" set screws.
6. Fasten the #4600-21 and #4600-20 tray supports to the top side of the disc. Secure with (#FF105) 1/4" x 3/4" flange screws and 1/4" flange nuts.
7. When the trays are ready to be loaded, place the tray under the #4600-20 top flap and lay on the tray base. The #4600-19 may have to be adjusted to center the supports over the #4600-07 tray base.



# #5600 FOUR TRAY CARROUSEL

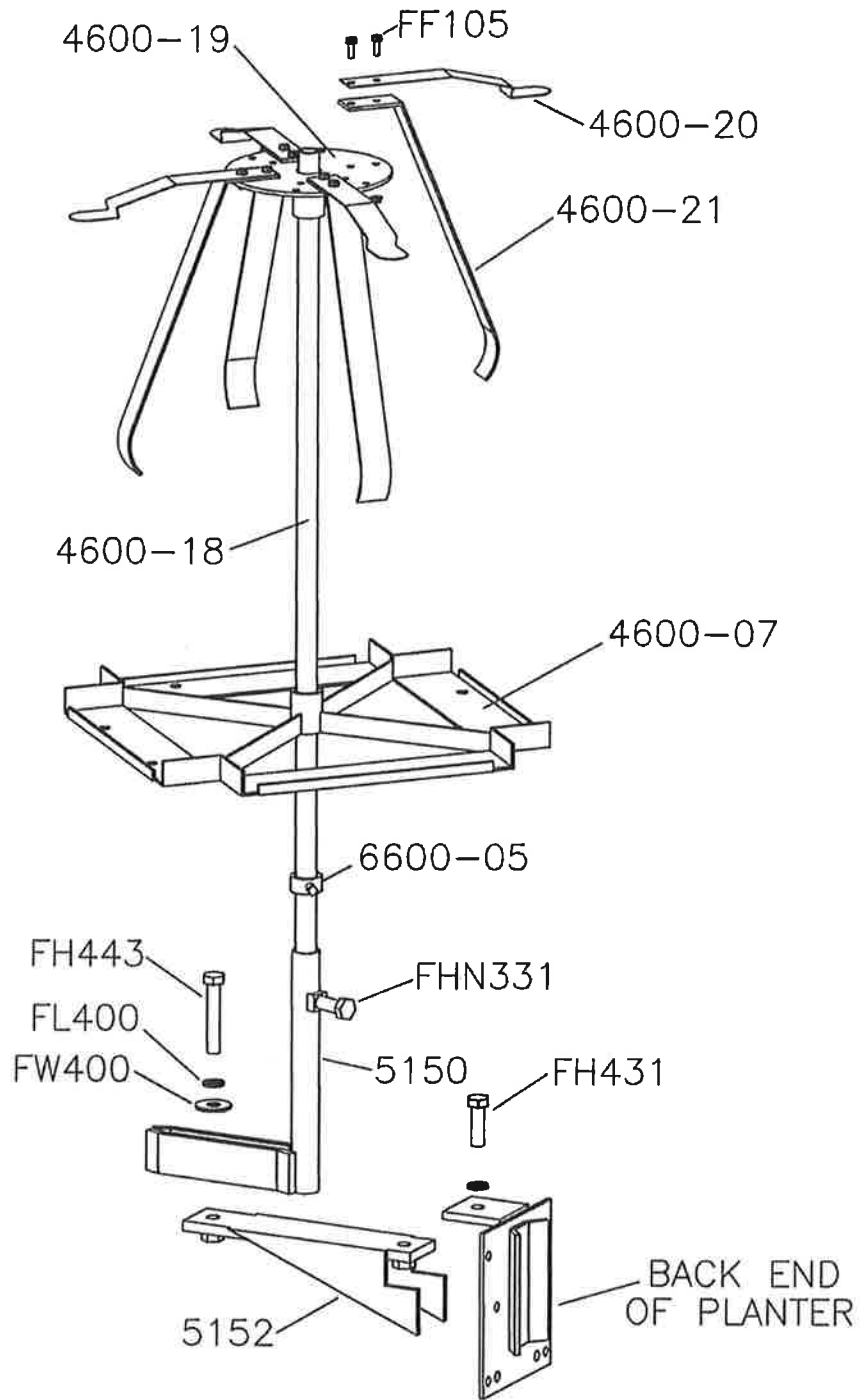

**FF105** 1/4 x 3/4" Flange Screw  
**FH431** 5/8 x 2" Hex Bolt  
**FH443** 5/8 x 3-1/2" Hex Bolt  
**FHN331** 1/2 x 1" Nylon Hex Bolt  
**FL400** 5/8" Lock Washer  
**FW400** 5/8" Flat Washer  
**4600-18** Carrousel Pipe

**4600-19** Top Disc  
**4600-20** Top Spring Plate  
**4600-21** Back Spring Plate  
**5150** Carrousel Arm  
**5151** Carrousel Base  
**6600-05** Set Collar  
**6600-07** Bottom Tray

# Model 5606 Carrousel Tray Holder Assembly Instructions

1. Place the #5533 carrousel base onto the #5504 back plate of the Model 5000W. Secure on the bottom with the 3/8" hex nuts. Fasten at the top with the (#FH431) 5/8 x 2 hex bolt with lock washer and hex nut.
2. Place the #5150 Pipe holder on the #5533 carrousel base. Secure and adjust using the (#FH443) 5/8 x 3-1/2 hex bolt. Use a lock washer and flat washer with the hex bolt.
3. Slip the set collar #6600-05 over the long pipe #4600-18. Slide the long pipe into the pipe holder #5150 until it can be seen on the bottom. Tighten the square head screw on the collar to keep the pipe in place. The collar may be adjusted later to the proper height needed for each operator.
4. Slide the tray frame, #6600-07, with bent edges up, onto pipe #4600-18. Tighten the two 3/8" set screws so the bottom of the tray frame is above the six-cup feeder head.
5. Place the #4600-19 disc on the long pipe. Measure 26-1/2" from the #6600-07 tray frame to the round disc. Tighten the 3/8" set screws.
6. Fasten 6 #6600-14 extension plates to the top disc. Use two (#FF105) 1/4" x 3/4" flange screws and 1/4" flange nuts to secure.
7. Assemble spring #4600-20 and support #4600-21 to the #6600-14 extension bracket. Secure with two 1/4" x 3/4" flange screws. Adjust the #4600-19 top disc to insure the springs and supports line up with the center of the tray supports.

# #5606 SIX TRAY CARROUSEL

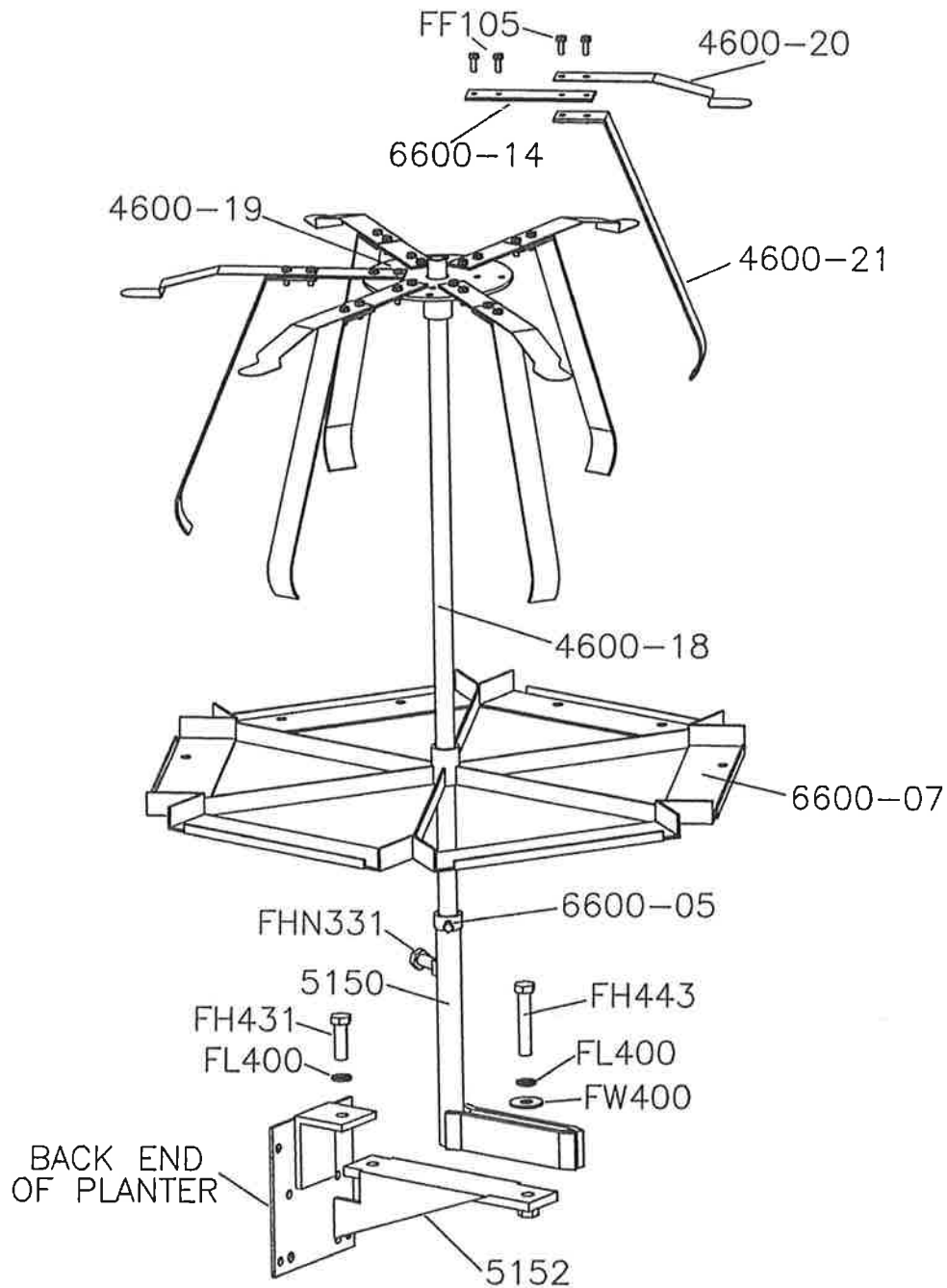

<b>FF105</b>	<b>1/4 x 3/4" Flange Screw</b>	<b>4600-20</b>	<b>Top Spring Plate</b>
<b>FH431</b>	<b>5/8 x 2" Hex Bolt</b>	<b>4600-21</b>	<b>Back Spring Plate</b>
<b>FH443</b>	<b>5/8 x 3-1/2" Hex Bolt</b>	<b>5150</b>	<b>Carousel Arm</b>
<b>FHN331</b>	<b>1/2 x 1" Nylon Hex Bolt</b>	<b>5151</b>	<b>Carousel Base</b>
<b>FL400</b>	<b>5/8" Lock Washer</b>	<b>6600-05</b>	<b>Set Collar</b>
<b>FW400</b>	<b>5/8" Flat Washer</b>	<b>6600-07</b>	<b>Bottom Tray</b>
<b>4600-18</b>	<b>Carousel Pipe</b>	<b>6600-14</b>	<b>6-Tray Extension</b>
<b>4600-19</b>	<b>Top Disc</b>		

# MODEL 5000W OPERATION

## A. Timing Instructions

1. The diagram below is on the side of your transplanter. The arrows signify the location of a tube with the lower keyway straight up.
2. Follow the instructions below carefully. This must be done with each transplanter.

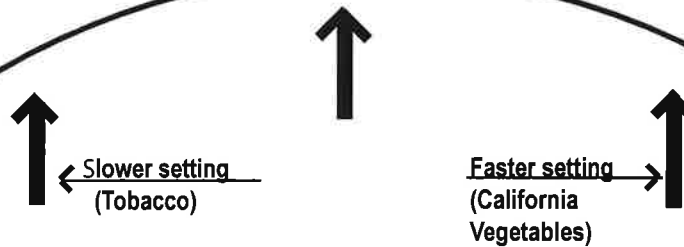

### Timing Instructions for the Model 5000W

1. Locate the timing arrows on this guard.
2. To insure that each unit is in time, follow these steps (this must be done for each unit separately).
  - a. Observe the keyway on the shaft located in the open hole on this guard.
  - b. Turn the drive wheel slowly until the keyway is at the 12 o'clock position and the arrow is pointing at it. Keyway must remain at the 12 o'clock position while adjusting the cups.
  - c. If the center arrow is pointing at the center of the bottom of any of the 6 cups, your unit is in time for approximately 80-100 plants per minute.
  - e. The cups are adjustable from the center arrow for slower or faster planting speeds.
3. Follow these steps if the timing must be adjusted:
  - a. Loosen the 1/2" bolt at the top of the six cup feeder head.
  - b. Remember to keep the keyway at the 12 o'clock position.
  - c. Rotate the six cup feeder head to your desired position from the center arrow.
  - d. Tighten the 1/2" bolt and proceed.

Keyway in shaft



## B. Sizing cell to shoe

1. Take a cell and place into the rear of the shoe.
2. Using a 15/16" wrench, adjust the bolt on the outside of the shoe to widen or narrow the shoe. Cell must fit snugly, stopping near bottom of shoe.



**Incorrect**  
- Narrow the shoe  
with adjustment  
bolt.



**Correct**



**Incorrect**  
- Widen the shoe  
with adjustment

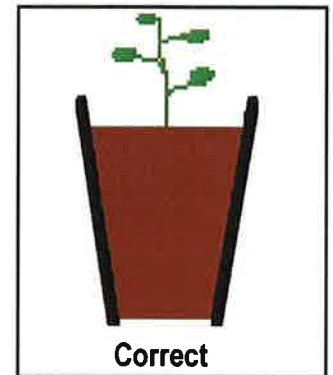

**Correct**

## C. Level Planting

1. Lower the Model 5000W transplanter into the soil.

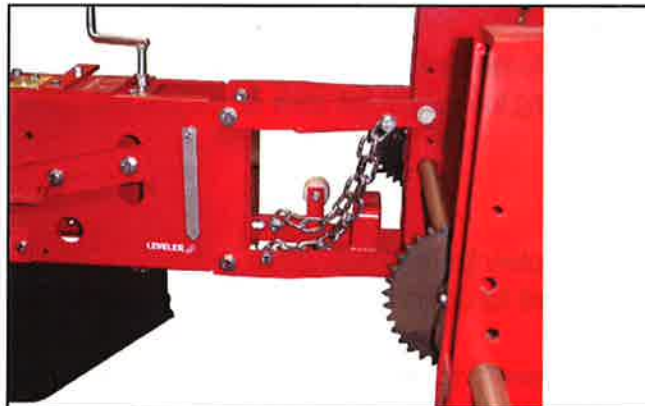

2. Set height of gauge wheels so parallel hitches are level with frame. Use the leveler on the side of the transplanter to insure level planting.
3. Toolbar Pitch- The toolbar can be pitched back to put extra pressure on the packing wheels.
  - a. Three point hitch, 803F 2-Row frame, or 803 4HF 4-Row Frame - Adjust the 3rd arm longer on the 3 point hitch for added packing pressure.

- b. Mechanical Transplanter's model 800-2 Row Trailer- Shorten the two turnbuckle arms equally to pitch toolbar down for added pressure (See diagram below).

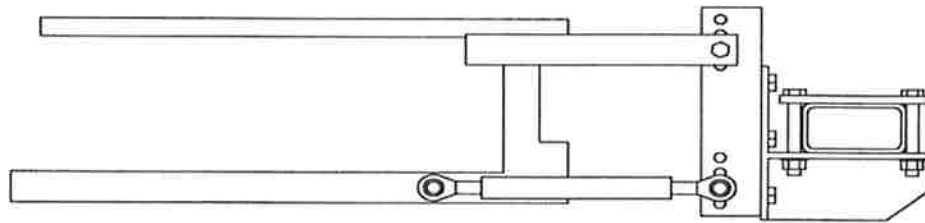

LEVEL PLANTING

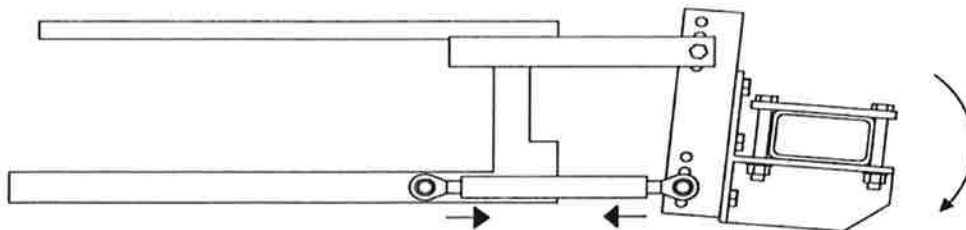

SHORTENING TURNBUCKLE WILL PITCH TOOLBAR DOWN FOR ADDED PACKING PRESSURE.

## D. Depth Control and Packing

1. If the depth of the cell planted is incorrect, turn the crank under the seat to set the shoe deeper or shallower.
2. The packing wheels can be adjusted closer together or further apart with the set screws found on the packing wheel hubs.  
Added pressure can be given to the back of the transplanter by lengthening the 3rd arm of the 3-point hitch or shortening the bottom link arms on the pull-type trailer.

## E. Water Valve Adjustment

1. The water valve is set at the factory for maximum stroke.  
Set the ball valve on side of unit for desired amount of water to be released with each plant.
2. If a smaller stroke is desired, remove the inspection plate in front of the gearbox. Raise the #5199 channel on the pump rod to decrease the stroke.  
**Do not over or under stroke valve or it will lock up the unit.**
3. Water placement can be adjusted to trip earlier or later than its current set position. To adjust, loosen the thumb screw on the dial located on the side of the transplanter. Start from the center position and move the dial in small increments. Turning the dial clockwise will cause the water to drop earlier and turning the dial counter-clockwise will cause it to drop later.
4. Drain the water out of the valve at the end of the season or the valve could freeze and be damaged.

# Service

Attention: Care should be taken while servicing the unit because of the bolt together construction of the main frame. NEVER remove the unit top plate, backplate, or shoe at the same time. Frame alignment could be jeopardized if this is done!

A. Resetting the transplanter to factory timing  
See page 10

B. Replacing the Shoe

1. Loosen and remove the two 3/8" bolts going into the bottom of the framework at the back of the shoe.
2. Remove the 3/8" bolt from the front of the shoe.

C. Kicker spring replacement

1. Remove any plant racks or carrousel tray holders
2. Loosen the four bolts holding the back plate on
3. Remove the back plate for easy access inside the transplanter

## Machine Improvements

Mechanical Transplanter Co. is always striving to make improvements on their line of equipment. Mechanical Transplanter Co. reserves the right to make improvements and changes at any time without incurring obligations to make such changes or additions to equipment previously sold.

### STANDARD CHART

**Model 5000W Spacing Chart**

Spacing	Use Sprocket Arrangement		
		11"	B2D
5-1/2"	A1D	12"	A4C
6-1/2"	A2D	14"	A5C
7-1/2"	A3D	16"	A6C
8-1/2"	A4D	17"	B3C
9"	A2C	19"	B5D
9-1/2"	A5D	20"	B6D
10-1/2"	A3C	23"	B5C
10-3/4"	A6D	26"	B6C

To change cluster spacings, just slide cluster over to align desired sprocket above either sprocket A or B.

To change C or D spacing, move sprocket E over C or D.

**Model 5000W Wide Spacing Chart**

Spacing	Use Sprocket Arrangement		
9"	A1D	20"	A4C
10-1/2"	A2D	23"	B3D
13"	A3D	24"	A5C
15"	A4D	26"	A6C
16-1/2"	A5D	30-1/2"	B5D
17-1/2"	A3C	35"	B6D
18-1/2"	B2D	40"	B5C
19-1/2"	A6D	48"	B6C

35 Tooth on Jackshaft  
10 Tooth on Transplanter

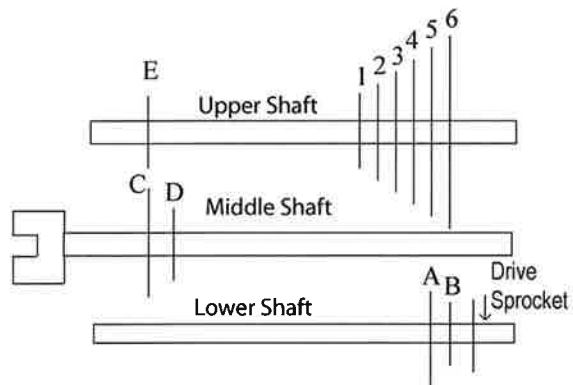

22 Tooth on Jackshaft  
12 Tooth on Transplanter

# TROUBLE SHOOTING

Reminder: Cell-type setters, such as the Model 5000W, require a firm, rootbound, and moist cell for consistent planting. A poor quality cell directly affects the performance of the transplanter.

<b>PROBLEM</b>	<b>CAUSE</b>	<b>SOLUTION</b>
Plants fall on kicker	Machine is out of time	Review decal on side of transplanter or see page 10 in the manual
	Poor cell quality and/or dry cells	Water cells lightly to help them drop faster
Plants are buried or lying top of the soil	The furrow opening shoe is not adjusted properly	See the diagram on page 11 of this manual
	Poor cell quality	Make sure the cells are fully intact when removing from the tray
Furrow is not filling in properly	Transplanter is not running level	Adjust the gauge wheels so the scissors hitch is running level. Toolbar should be about 14" off the ground.
	There is not enough packing pressure	Adjust toolbar pitch to put more pressure on the back of the unit: See page 12
	Use as last resort	Rototill soil.
Kicker is not moving	Drive wheel is not touching the ground	Turn gauge wheel crank to lower tire
	Transtorque loose	Tighten the 1" transtorque on the main drive shaft
Plants are being flooded out of shoe	Ball valve on side of transplanter opened too much	Close ball valve until proper water flow is achieved



# Limited Warranty

Mechanical Transplanter Company warrants each item of new equipment manufactured by Mechanical to be free from defects in material and workmanship under normal use and service.

The obligation of Mechanical Transplanter Company under this LIMITED WARRANTY is limited to repairing or replacing as Mechanical may elect, and any parts that prove, in Mechanical's judgment, to be defective in material and workmanship within the first season's use or 45 consecutive days after initially placing equipment in operation, whichever occurs first. Any outside work or alterations without Mechanical's written approval will render the LIMITED WARRANTY void.

Mechanical's obligation specifically excludes any liability for consequential damages, such as loss of profits, delays, expenses, damage to goods or property used in connection with or processed in or by the product sold, or damage to the product sold from whatsoever cause, whether or not such loss is due to negligence of selling dealer of Mechanical Transplanter Company.

This limited warranty shall not apply to any item or machine which shall have been operated in a manner not recommended by the Company nor which shall have been repaired, altered, misused, damaged in an accident, neglected, tampered with or used in any way which in the Company's opinion adversely affects its performance and results.

No person is authorized to give any other warranties or to assume any other liability on behalf of Mechanical Transplanter Company, unless made in writing by Mechanical.

This limited warranty covers repair or replacement of Mechanical Transplanter Co. equipment only and does not cover crop loss, downtime, labor, damage to other equipment, etc.

This limited warranty does not apply to exterior finishes, tires, chain links, bearings, or any other items sold by Mechanical Transplanter Co., but warranted by the original manufacturer except to the extent of their individual manufacturer's warranty.

THIS LIMITED WARRANTY IS IN LIEU OF ALL OTHER WARRANTIES, EXPRESSED OR IMPLIED. WARRANTIES OF MERCHANTABILITY AND FITNESS FOR PARTICULAR PURPOSE ARE EXCLUDED, AS ARE ALL OTHER REPRESENTATIONS TO THE USER-PURCHASER, AND ALL OTHER OBLIGATIONS OR LIABILITIES, INCLUDING LIABILITY FOR INCIDENTAL AND CONSEQUENTIAL DAMAGES, ON THE PART OF MECHANICAL OR THE SELLER.

## Safety Precautions

1. Make sure tractor is stopped and in neutral with the transplanter lowered to the ground before getting on and off the unit.
2. No operator is allowed to be on the unit as it is raised and lowered.
3. No operator is allowed on the transplanter as it is transported to or from the field.
4. All operators must be seated before movement begins and remain seated until the transplanter is completely stopped.
5. Never leave the transplanter in the raised position.
6. Keep all shields and guards in place when operating the transplanter.
7. Never attempt repairs or maintenance while the transplanter is in motion.
8. Never put the tractor in reverse while the transplanter is on the ground.
9. Follow all safety instructions supplied by the tractor manufacturer to which the transplanter is mounted.

**Mechanical Transplanter Company, LLC**

**1150 Central Avenue Holland, MI 49423-5230**

**Toll Free: 800-757-5268 \* Phone: 616-396-8738**

**Fax: 616-396-3619**

**website: [mechanicaltransplanter.com](http://mechanicaltransplanter.com)**

**e-mail: [mtc@mechanicaltransplanter.com](mailto:mtc@mechanicaltransplanter.com)**