

# Model 5000WD Parts List

12	Direct drive tire and rim	5096	Door hinge pin
15	Chain guard clip pin	5097	Door for cup
31	Direct drive rear frame	5099	Pipe timing lock
32	Wheel chain tightener spring	5124	1-1/2" Chain tightener roller
33	Wheel chain tightener arm	5141	Twin cup mounting
35	Lift chain	5156	Shoe adjustment bolt assembly
38	Wheel hub with sprocket	5189	Hose barb
39	Direct drive front frame	5190	Coupler
40	Left clamp less u-bolt	5191	90 Degree elbow
41	34 Link, #32 flat chain	5193	Thumb screw
42	Right clamp less u-bolt	5195	Large inside dial
43	1/2" Bushing with shoulder	5196	Small outside dial
44	Chain lift plate	5197	Water dial guard
48	Right clamp	5199	Trip channel on pump rod
49	Left clamp	5501	Side plate, guard side
328	3/4" Flange block bearing	5502	Side plate, water side
373	Unit chin tightener and kicker spring	5503	Front plate
376S	Tension spring	5504	Back plate
381	7 Tooth spacing sprocket	5505	Top plate with gear box mounting
381I	7 Tooth idler sprocket	5506	Inspection plate
382	8 Tooth spacing sprocket	5507	Wheel yoke
383	9 Tooth spacing sprocket	5508	Long nut for wheel adjustment
384	10 Tooth spacing sprocket	5509	Crank assembly
385	11 Tooth spacing sprocket	5510	Front shoe mount bracket
386	Direct drive (drawbar) shaft	5512	Footrest bracket
386P	Clip pin for drawbar shaft	5513	Footrest mounting plate
434	7/8" Oilite bushing	5514	Adjustable footrest bracket
462	11 Tooth drive wheel sprocket	5515	Footrest
521	Roll pin	5519	Guard support bracket
522	Clip pin	5520	Right 5000W axle
529CO	5000W wheel scraper blade	5521	Left 5000W axle
533CO	Scraper bracket with blades	5522	3-1/2" Wide packer wheel
610 89	Air valve float ball	5523	3" Wide packer wheel
611	Nylon water valve seat	5524	L-bracket for wheel scrapers
612L	Ball valve with brass pin (after 2000)	5525	Wheel scraper mounting plate
639AHDD	Adjustable packing wheel hub	5526	Kicker arm mounting plate
726L	L-shaped seat bracket	5527	Kicker arm
740	7/8" U-bolt	5528	Spur gear guard
926	Sealed bearing	5529	Water valve housing
1000VS	Water valve shut off	5530	Water valve roller trip assembly
4610	10 Tooth, 5/8" bore sprocket	5531	Drop tube
5000K	Kicker deflector	5532	Water valve for 5000W
5000WWS	Plastic shield only	5550	Jackshaft
5001	Water valve cap	5551	18 Tooth spacing gear
5006	Water valve "T"	5552	20 Tooth spacing gear
5009L	Water pump rod (after 2000)	5553	22 Tooth spacing gear
5026	Adjustable shoe	5554	24 Tooth spacing gear
5026P	Poly sided adjustable shoe	5555	26 Tooth spacing gear
5026S	Shoe skag	5556	27 Tooth spacing gear
5035	Hex locking plate	5557	32 Tooth spacing gear
5036	Center post for cups	5558	38 Tooth spacing gear
5037	Cup mounting bracket	5560	18 Tooth wheel sprocket
5038	Plastic deflector cap for cups	5561	Guard holder
5039	Cup tube	5562	Rear guard
5040	90 Tooth spur gear	5563	Unit drive chain
5041	2 Shaft gear box	5564	Unit chain tightener
5042	Cup trip bracket	5565	Direct drive mounting plate
5044	15 Tooth spur gear	5566	Direct drive chain guard
5045	5/8" flange block bearing	FC167	5/16x2" Carriage bolt
5047	Aluminum kicker	FH211	3/8x1-1/4" Hex head bolt
5056	Kicker cam	FH333	1/2x1-1/4" Hex head bolt
5067	Shoe cleaner	FSC200	3/8" Set collar
5070	Windshield	FSC500	7/8" Set collar
5073	Front toolbar mounting plate	FW200	3/8" U.S.S. flat washer
5095	Cup door spring	FW450	3/4" U.S.S flat washer

Mechanical Transplanter Company, LLC

1150 Central Avenue

Holland, Michigan 49423

Phone: (616) 396-8738 \* Fax: (616) 396-3619

www.mechanicaltransplanter.com \* mtc@mechanicaltransplanter.com

FH333  
 5038  
 5099  
 5035  
 5036  
 FMB400  
 5070  
 (5000WWS-PLASTIC SHIELD ONLY)  
 5000K

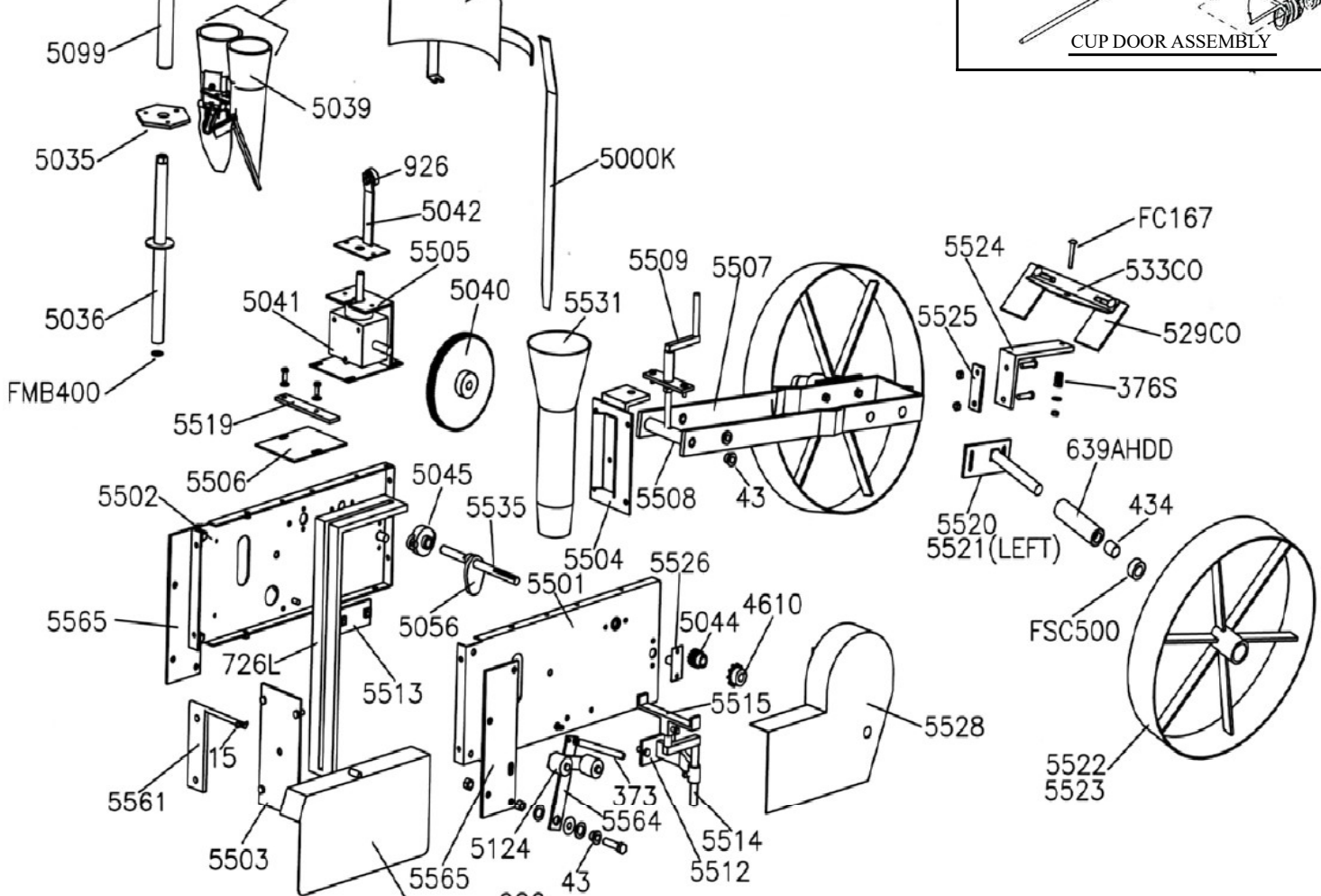
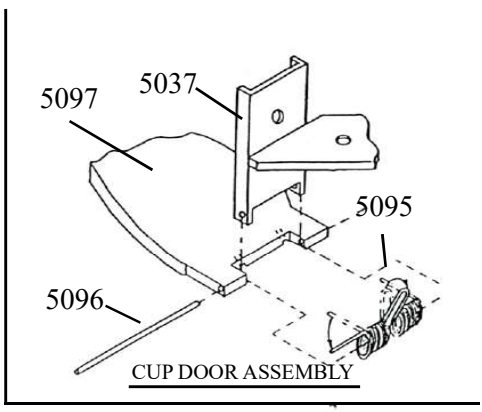

WATER VALVE & TRIP PARTS

WATER VALVE & TRIP PARTS

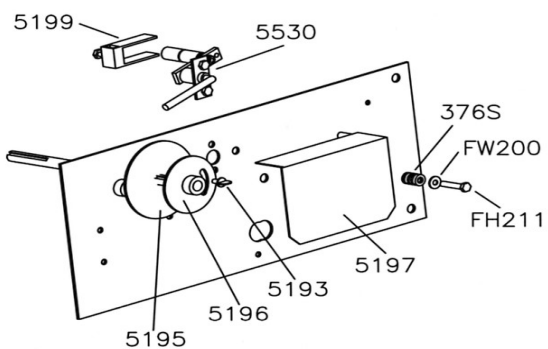
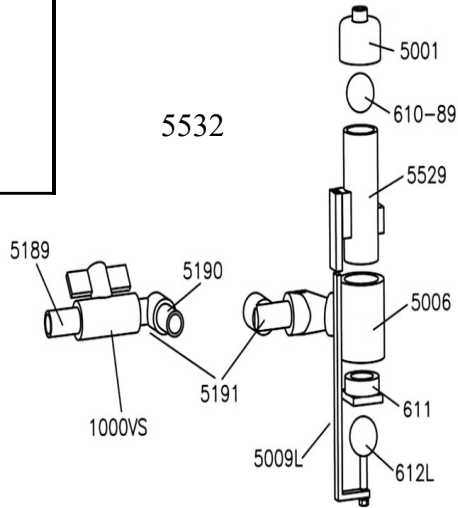

# DIRECT DRIVE

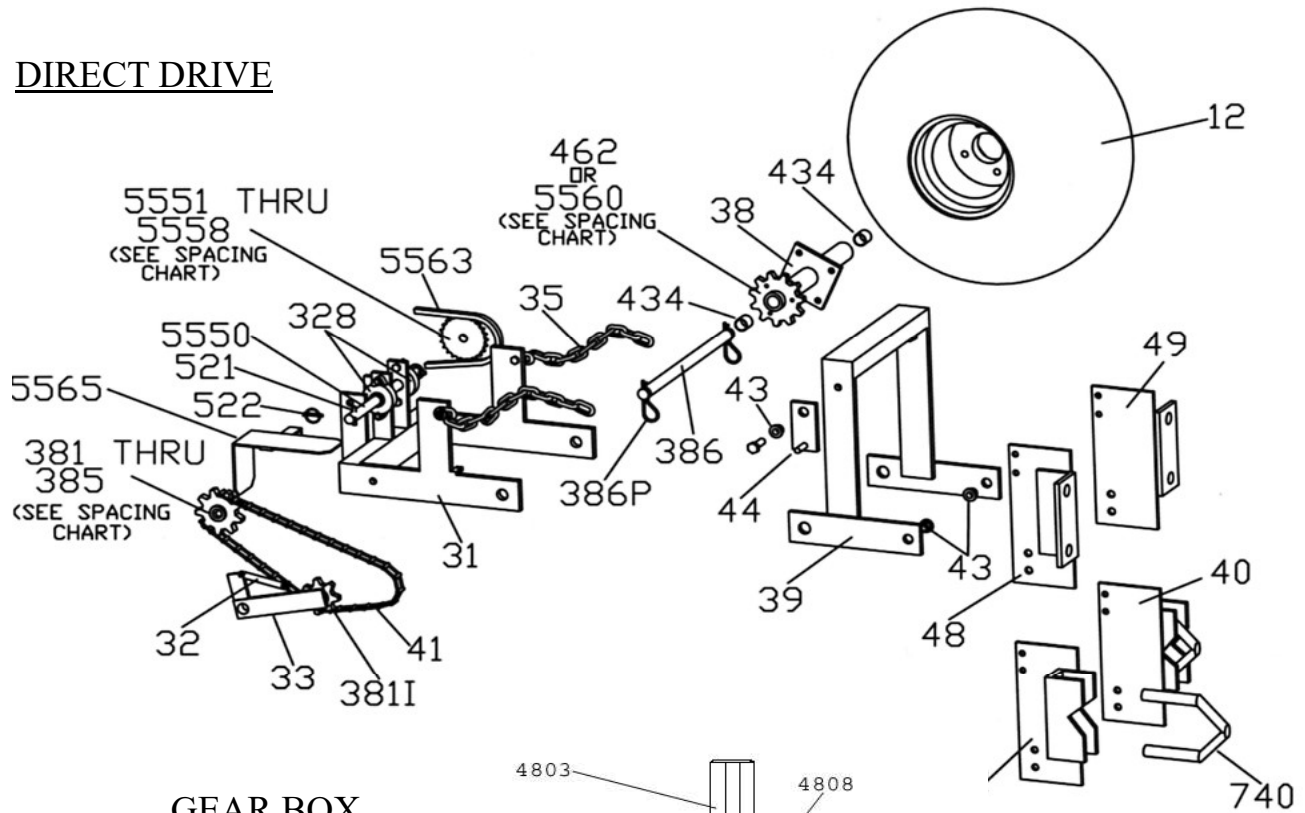

## GEAR BOX

- 4801 Gear box main housing
- 4802 Gear box pinion housing
- 4803 Gear box pinion shaft
- 4805 Gear box pinion shaft gear
- 4806 Gear box input shaft gear
- 4807 Gear box bearing
- 4808 Gear box seal
- 4809 Gear box large snap ring
- 4811 Gear box pipe plug
- 4812 Gear box key
- 4814 Gear box small snap ring
- 5136 Gear box input shaft

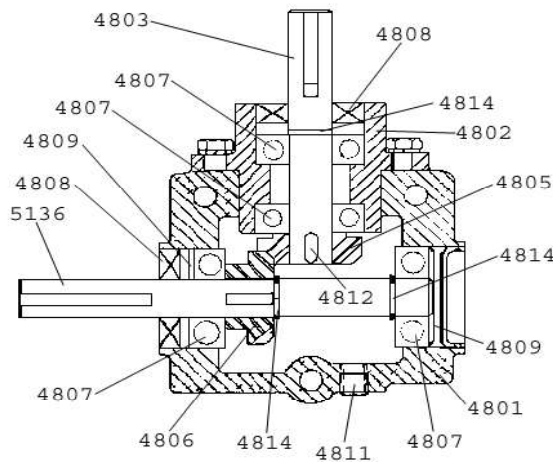

**MODEL 5000WD CLOSE SPACING CHART**  
18 Tooth on Drive Wheel

Metal Plate Sprocket	Plastic Sprocket				
	7	8	9	10	11
38	7"	8-1/2"	9-1/2"	10"	11"
32	9"	10"	12"	13"	14"
27	11"	12-1/2"	13-1/2"	15"	16-1/2"
24	12"	13"	14"	17"	19"
18	16"	17-1/2"	20"	22-1/2"	26"

**MODEL 5000WD WIDE SPACING CHART**  
11 Tooth on Drive Wheel

Metal Plate Sprocket	Plastic Sprocket			
	7	8	9	10
18	24"	28-1/2"	32"	35"
20	22-1/2"	26"	28"	31-1/2"
22	21"	23"	26"	30"
24	19"	21"	24"	27"
26	16-1/2"	20"	22"	24-1/2"

### H825 Single Row Hitch

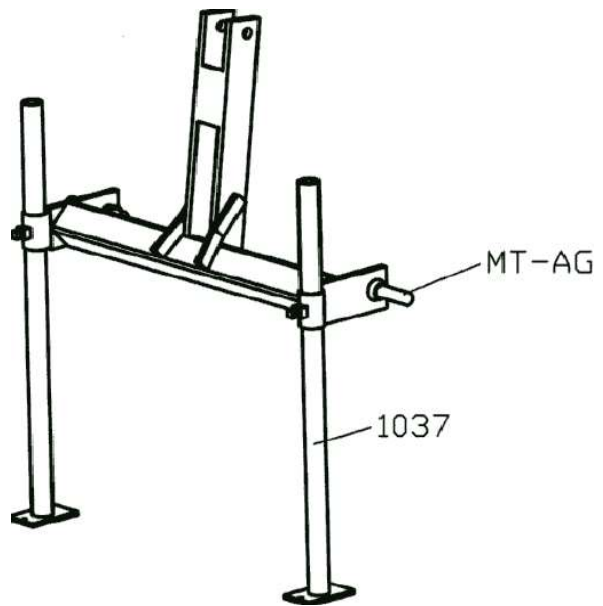

### B855 Barrel Mount

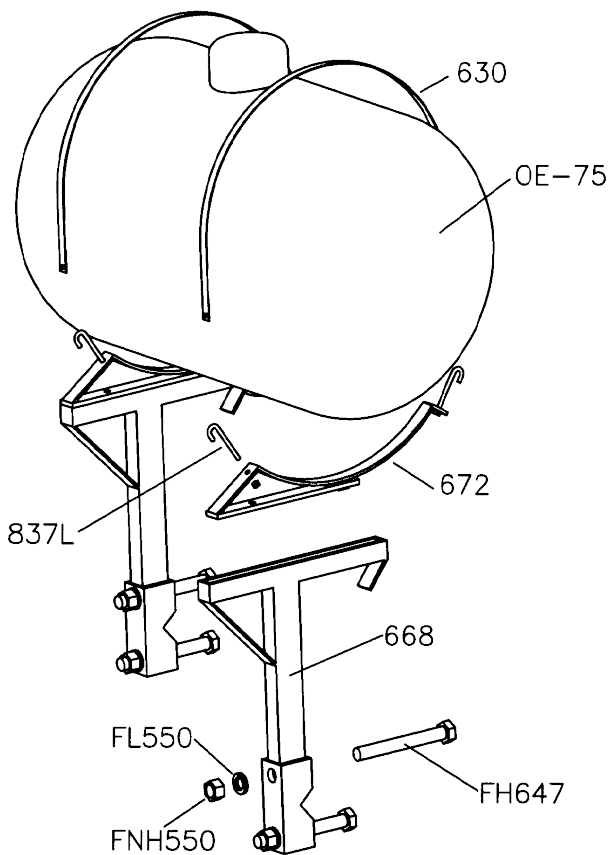

- 630 Barrel strap
- 668 Barrel mount upright
- 672 Barrel mount saddle
- 837L 5/16" J-bolt
- 1037 Pipe stand leg
- FH647 1x9" hex head cap screw
- FL550 1" lock washer
- FNH550 1" hex nut
- MT-AG hitch pin
- OE-75 60 gallon barrel

## 5026DDS & 5026DDSP Double Disc/Poly Double Disc Shoe

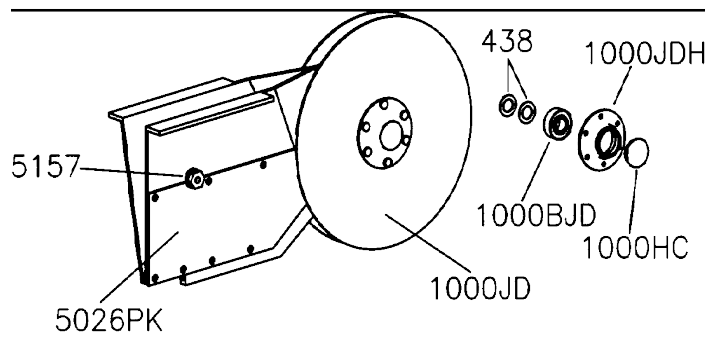

438	3/4" machinery bushing
1000BJD	Double disc bearing
1000HC	Double disc hub cap
1000JD	Disc with hub
1000JDH	Hub with fasteners
5026PK	Poly kit
5157	Shoe adjustment bolt assembly

## OE-74 Fiberglass Seat

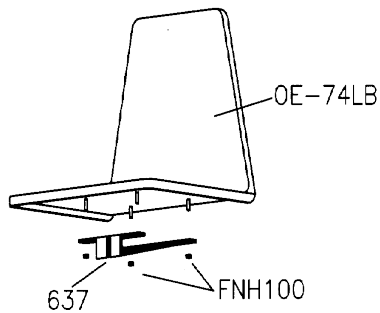

636R	Cushion seat bracket (red)
637	Fiberglass seat bracket
OE-74LB	Fiberglass seat less bracket
OE-77LB	Cushion seat less bracket
FH159	5/16x1" hex head cap screw
FNH100	1/4" hex nut

## OE-77 Cushion Seat

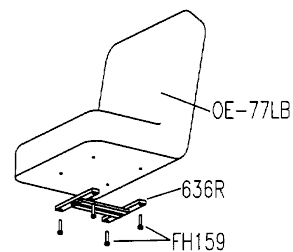

# Carrousel Tray Holders

## 5600

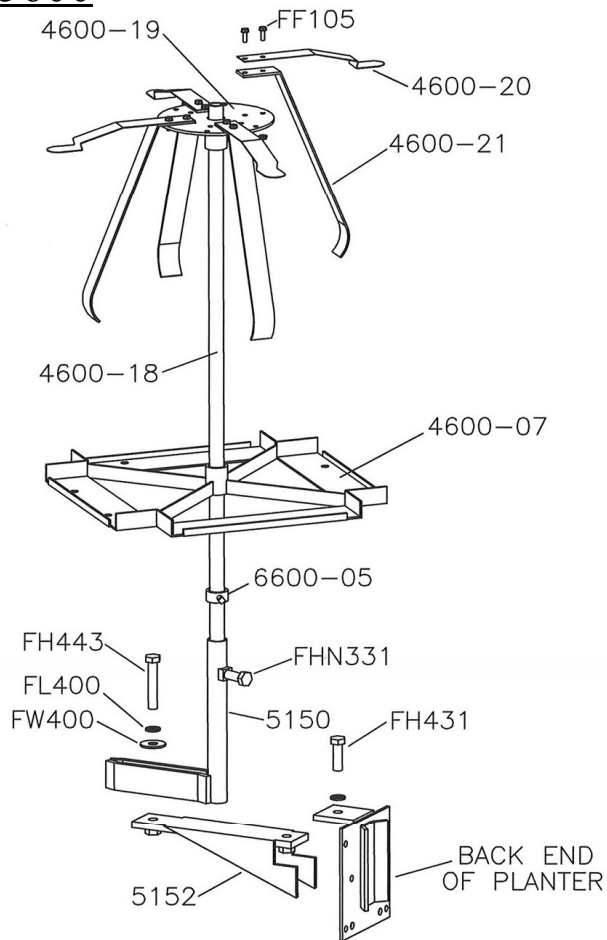

## 5606

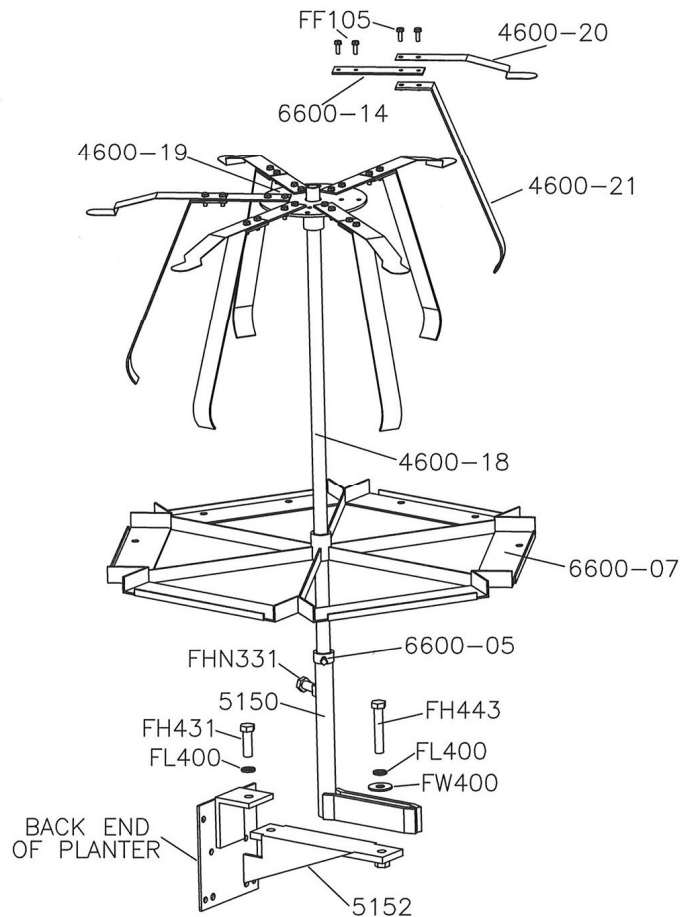

## 5601

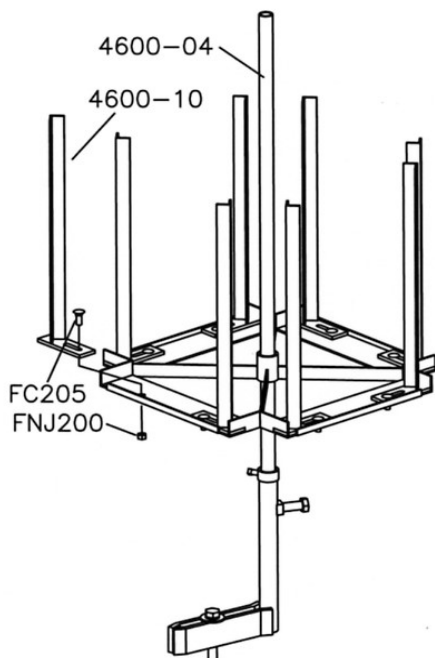

4600-04	Plastic Tray Pipe
4600-07	4 Place Bottom Tray
4600-10	Plastic Tray Holder Arm
4600-18	Carrousel Pipe
4600-19	Top Disc
4600-20	Top Spring Plate
4600-21	Back Spring Plate
5150	Carrousel Arm
5152	Carrousel Base
6600-05	Carrousel Collar
6600-07	6 Place Bottom Tray
FC205	3/8 x 3/4" Carriage Bolt
FF105	1/4 x 3/4" Flange Bolt
FH431	5/8 x 2" Hex Head Bolt
FH443	5/8 x 3-1/2" Hex Head Bolt
FHN331	1/2 x 1" Nylon Hex Head Bolt
FL400	5/8" Lock Washer
FNJ200	3/8" Jam Nut
FW400	5/8" Flat Washer

# Coulter Options

## OE 65 5000

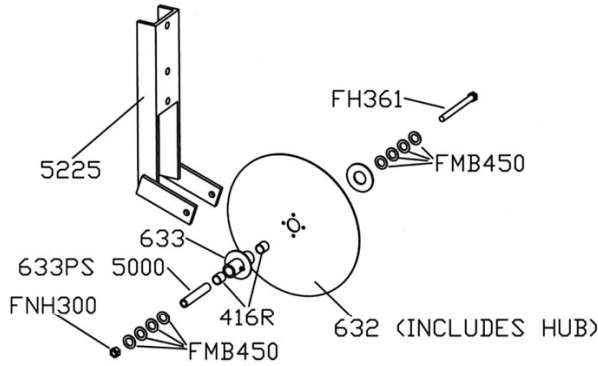

- |            |   |
|------------|---|
| 43         | 1/2" Bushing with Shoulder              |
| 416R       | 3/4" Bushing for Coulters               |
| 632        | 14" Coulter with Hub                    |
| 633        | Coulter Hub (Includes 416R's)           |
| 633PS 5000 | Pipe Spacer                             |
| 5225       | Bracket for Rigid Coulter Assm.         |
| 5226       | Bracket for Spring Loaded Coulter Assm. |
| 5227       | Top Scissor Arm                         |

## OE 65 5000SP

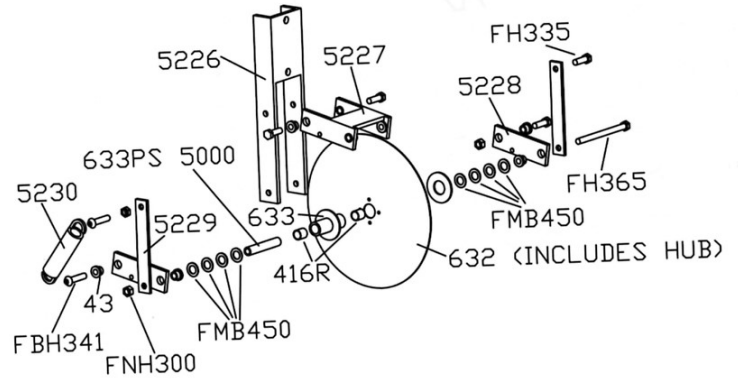

- |        |                             |
|--------|-----------------------------|
| 5228   | Bottom Scissor Arm (ea)     |
| 5229   | Back Leg for Scissor        |
| 5230   | Coulter Spring              |
| FBH341 | 1/2x2-1/4" Button Head Bolt |
| FH335  | 1/2x1-1/2" Hex Head Bolt    |
| FH361  | 1/2x5-1/2" Hex Head Bolt    |
| FH365  | 1/2x6-1/2" Hex Head Bolt    |
| FMB450 | 3/4" Machinery Bushing      |
| FNH300 | 1/2" Hex Nut                |

# Row Marker Options

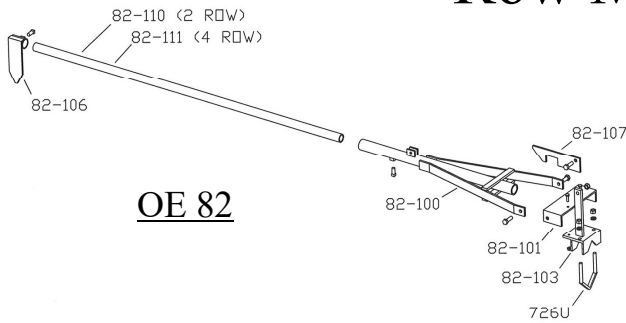

## OE 82

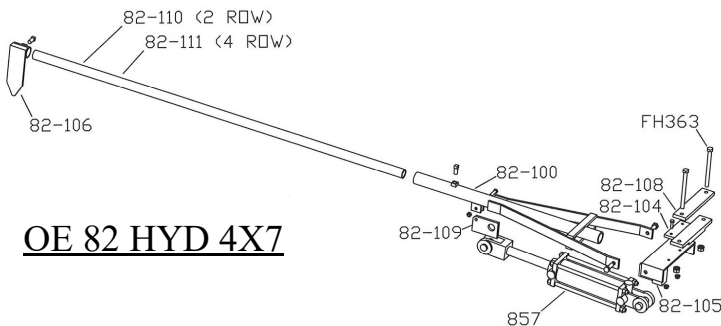

## OE 82 HYD 4X7

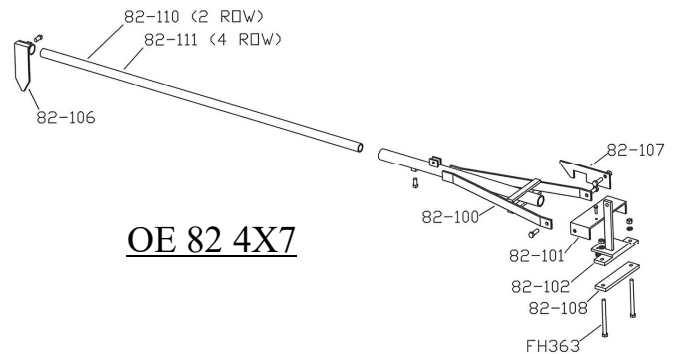

## OE 82 4X7

- |        |                               |        |                                |
|--------|-------------------------------|--------|--------------------------------|
| 82-100 | A-Frame                       | 82-108 | 1/2 x 2 x 9-1/8 Securing Plate |
| 82-101 | Swivel Bracket                | 82-109 | Cylinder Swivel                |
| 82-102 | Latch Bracket for 4x7 Bar     | 82-110 | 2-Row Pipe                     |
| 82-103 | Latch Bracket for Diamond Bar | 82-111 | 4-Row Pipe                     |
| 82-104 | Toolbar Mounting Bracket      | 726U   | 1/2" U-Bolt for Toolbar Clamps |
| 82-105 | Swivel with Cylinder Mount    | 857    | 3 x 8" Hydraulic Cylinder      |
| 82-106 | Marker Point                  | FH363  | 1/2 x 6" Hex Head Bolt         |
| 82-107 | Latch                         |        |                                |

# Safety Precautions

1. Make sure tractor is stopped and in neutral with the transplanter lowered to the ground before getting on and off the unit.
2. No operator is allowed to be on the unit as it is raised and lowered.
3. No operator is allowed on the transplanter as it is transported to or from the field.
4. All operators must be seated before movement begins and remain seated until the transplanter is completely stopped.
5. Never leave the transplanter in the raised position.
6. Keep all shields and guards in place when operating the transplanter.
7. Never attempt repairs or maintenance while the transplanter is in motion.
8. Never put the tractor in reverse while the transplanter is on the ground.
9. Follow all safety instructions supplied by the tractor manufacturer to which the transplanter is mounted.

## **MACHINE IMPROVEMENTS**

*MECHANICAL TRANSPLANTER CO. IS ALWAYS STRIVING TO MAKE IMPROVEMENTS ON THEIR LINE OF EQUIPMENT. MECHANICAL TRANSPLANTER CO. RESERVES THE RIGHT TO MAKE IMPROVEMENTS AND CHANGES AT ANY TIME WITHOUT INCURRING OBLIGATIONS TO MAKE SUCH CHANGES OR ADDITIONS TO EQUIPMENT PREVIOUSLY SOLD.*

## **Limited Warranty**

Mechanical Transplanter Company warrants each item of new equipment manufactured by Mechanical to be free from defects in material and workmanship under normal use and service.

The obligation of Mechanical Transplanter Company under this LIMITED WARRANTY is limited to repairing or replacing as Mechanical may elect, and any parts that prove, in Mechanical's judgment, to be defective in material and workmanship within the first season's use or 45 consecutive days after initially placing equipment in operation, whichever occurs first. Any outside work or alterations without Mechanical's written approval will render the LIMITED WARRANTY void.

Mechanical's obligation specifically excludes any liability for consequential damages, such as loss of profits, delays, expenses, damage to goods or property used in connection with or processed in or by the product sold, or damage to the product sold from whatsoever cause, whether or not such loss is due to negligence of selling dealer of Mechanical Transplanter Company.

This limited warranty shall not apply to any item or machine which shall have been operated in a manner not recommended by the Company nor which shall have been repaired, altered, misused, damaged in an accident, neglected, tampered with or used in any way which in the Company's opinion adversely affects its performance and results.

No person is authorized to give any other warranties or to assume any other liability on behalf of Mechanical Transplanter Company, unless made in writing by Mechanical.

This limited warranty covers repair or replacement of Mechanical Transplanter Co. equipment only and does not cover crop loss, downtime, labor, damage to other equipment, etc.

This limited warranty does not apply to exterior finishes, tires, chain links, bearings, or any other items sold by Mechanical Transplanter Co., but warranted by the original manufacturer except to the extent of their individual manufacturer's warranty.

THIS LIMITED WARRANT IS IN LIEU OF ALL OTHER WARRANTIES, EXPRESSED OR IMPLIED. WARRANTIES OF MERCHANT ABILITY AND FITNESS FOR PARTICULAR PURPOSE ARE EXCLUDED, AS ARE ALL OTHER REPRESENTATIONS TO THE USER-PURCHASER, AND ALL OTHER OBLIGATIONS OR LIABILITIES, INCLUDING LIABILITY FOR INCIDENTAL AND CONSEQUENTIAL DAMAGES, ON THE PART OF MECHANICAL OR THE SELLER.