

# ***MODEL 5000WD***

***Assembly and Operators Manual***



**MECHANICAL TRANSPLANTER COMPANY, LLC**

1150 CENTRAL AVENUE \* HOLLAND, MI 49423-5230

Phone: 616-396-8738 \* Fax: 616-396-3619

website: [www.mechanicaltransplanter.com](http://www.mechanicaltransplanter.com)

e-mail: [mtc@mechanicaltransplanter.com](mailto:mtc@mechanicaltransplanter.com)



# **TABLE OF CONTENTS**

***1. Assembly***

***2. Carrousel Tray Holder***

***3. Operation and Timing***

***4. Service***

***5. Gauge Wheel Drive Spacing Chart***

***6. Troubleshooting***

***7. Parts List***

# 5000WD Drive Wheel Assembly Instructions



1. Take the green seat brace and red chain guard support bracket and loosely bolt together using one 1/2 x 1-1/2" carriage bolt and 1/2" nut.



3. Bolt front drive wheel to frame using four 1/2 x 1-1/4" bolts and four 1/2" washers and four 1/2" nuts. Washers go on outside of frame as shown.



5. After chain tightener is in place lay chain over sprockets and around chain tightener rollers as shown.



2. Slide the red bracket on inside of frame and the green seat brace on outside of the front frame plate. Secure with second 1/2 x 1-1/2" carriage bolt and 1/2" nut through bottom hole. Adjust seat brace up or down for proper height.



4. Slide #43 bushing onto 1/2 x 2" bolt. Place two 3/4" machinery bushings over the #43 bushing. Insert bolt into front of the chain tightener bracket. Place the second #43 bushing on opposite side of chain tightener bracket. Insert complete assembly into hole on frame as shown in Photo #5 and secure with 1/2" nut.



6. Take #373 spring and hook it onto chain tightener. Extend spring and fasten in hole on flat spring holder as shown.



7. Re-install the back round guard. Then slide front guard over pin fastened to seat brace in step 2 and secure with #17 clip pin.

## Instructions for Direct Drive Clamps

The following instructions are for mounting the direct drive clamps to your Model 5000WD unit. although the pictures show the 2-1/2" clamps. Use these instructions for any clamp style. They all mount the same way.



1. Insert a metal bushing from the inside of the frame. Put one of the 1/2 x 1-1/2" bolts through the bushing also from the inside.



2. Attach the clamp to the bolt in the **top** hole of the bottom set of large holes. Secure with a 1/2" hex nut.
3. If you have a Model 5000WDB-3 or 5000WD-2 follow directions below for one clamp side only. To mount safety bar on other clamp side, see page 5. In the top set of holes, place a 7/16 x 1-1/4" bolt through the top hole.



4. Slide the end link of the chain onto the bolt.
5. Secure the chain with a 3/8" washer and then a 7/16" hex nut. Make sure the nut is very tight.

**Inform MTC of the size of toolbar and the correct clamps will be shipped with unit. Dealer or customer should notify us as to which type of toolbar clamps are needed if not ordering the toolbar from us.**



6. Use the same instructions for the other side of the Direct Drive Wheel.

**Note: The clamps may be reversed or fastened on the inside of the frame for narrow row spacings. If other clamps are in the way, two lefts or two rights may be used. The lower holes on the clamps are for higher toolbars on older models or on trailers where 3-point hitch will not go low enough. Correct height of toolbar is 14" to center.**

The Model 5000WD unit can now be mounted to your 3-point hitch or toolbar.  
Following is a list of fasteners that you must use for various toolbars.

### Toolbar Hardware List

- 2-1/2" or 2-1/4" Diamond Toolbar - 7/8" V-bend U-Bolts (2)
- 3" x 3" Flat Toolbar - 3/4" x 5" Hex Bolts (4)
- 4" x 4" Flat Toolbar - 3/4" x 6" Hex Bolts (4)
- 4" x 7" Toolbar - 3/4" x 9-1/2" Hex Bolts (4)
- 5" x 7" Toolbar - 3/4" x 7" Hex Bolts (4)
- 7" x 7" Toolbar - 3/4" x 9-1/2" (4)



**Shown with clamps reversed**



4" x 7" Toolbar Clamp. Use 2-3/4" x 9-1/2" Hex Bolts, 2-3/4" Hex Nuts and 2-3/4" Washers.

**Note: Bent bracket on front of clamp must be on top.**

## Model 5000WD Barrel Mounting and 3-Point Hitch Instructions



To mount this safety bar, you must remove the 7/16 x 1-1/4" bolt from on side of the direct drive wheel.

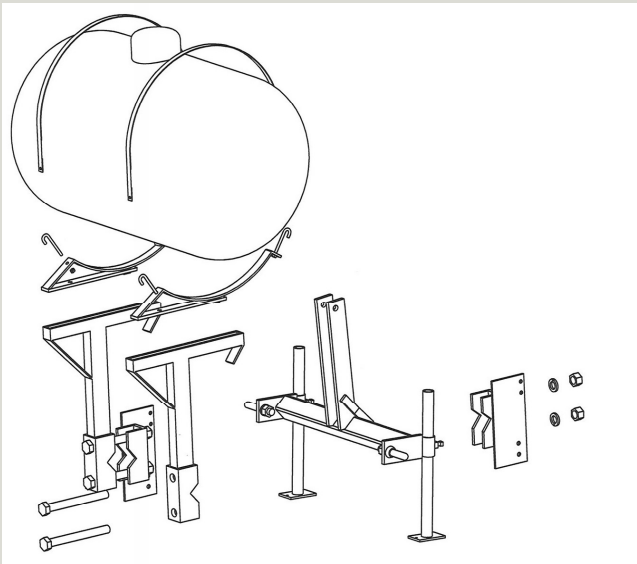

1. Locate the special 2-1/2" stud in your bag of bolts and nuts.
2. Turn a 7/16" hex nut all the way onto the stud.
3. Put the 7/16" washer on the stud next to the nut.
4. Place the lift chain up against the washer.
5. Slide the stud through the hole on the Direct Drive frame and secure with a 7/16" hex nut.
6. Assemble another stud the same way and fasten it to the top hole of the front Direct Drive clamp.
7. Attach the red seat safety bar to the stud on your drive wheel. The end with the hole must go on the clamp. The slotted end must go on the frame. After the safety bar is attached, place small clip pins through the small holes.

### 3-Point Hitch & Barrel Mounting

1. On the 3-Point hitch, connect the Category I hitch pins through the holes on the outside of the hitch. Put the pins in through the outside and secure with the lock washer and hex nut included with the pin.
2. Slide the green pipe stands up through the pipes on the hitch, then tighten by turning the set screw.

**Note: The following steps will be easier with two people**



3. Center the 3-Point hitch toolbar with the clamps on your transplanter. Next, line up one of the barrel mounting brackets with the direct drive clamps. Secure using two 1 x 8-1/2" bolts and hex nuts. Do the same with the other barrel mounting bracket.





Side view of B-3 mountings



4. Bolt barrel hoops onto B-3 supports using 1/2 x 3" hex bolt with 1/2" lock nut. Note below: the hoops can be mounted in a forward or back position, depending on clearance that you need for the tractor fenders etc.



5. Screw in the nipple into the bottom of the tank.



6. Insert J-bolts into the four holes on the barrel hoops. It works best to thread 5/16" nut onto J-bolt before hooking up barrel hoops.



7. The 55 gallon poly tank can now be mounted on top of the barrel mountings. Use the four J-bolts and the galvanized straps to secure the barrel to the mountings.

## WINDSHIELD

Install the windshield on the back of the transplanter. Use one 5/16 x 1/2" bolt with the small washer into the threaded hole by the large drop tube.



## FOOTREST

Adjust the footrests to desired position with the two square head set screws.



## 6-CUP CARROUSEL

Place the six tube carrousel feeder onto the vertical shaft of the gearbox. Align the key in the tubing with the keyway in the vertical shaft. Tighten using the square head set screw.



## MOUNTING FIBERGLASS SEAT

Turn fiberglass seat over and remove any plastic covering the threaded studs. Take your green seat bracket and mount it to the bottom of the seat with the side with the bend toward the front of the seat. Secure with four 1/4" hex nuts. Put the 1/2 x 1-1/2 carriage bolt through the brace and then through the L-shaped seat bracket. Secure with a 1/2" washer and hex nut.



## MOUNTING CUSHION SEAT

Put the 1/2 x 1-1/2" carriage bolt through the bottom of the green seat bracket before mounting the seat bracket to the seat. After placing the carriage bolt through the seat bracket, place the seat bracket on the cushion seat. Secure with four 5/16 x 1/2" hex head bolts. Place the seat on the L-shaped seat bracket and secure with a 1/2" washer and hex nut.



# MODEL 5000WD OPERATION

## A. Timing Instructions

1. The diagram below is on the side of your transplanter. The arrows signify the location of a tube with the lower keyway straight up.
2. Follow the instructions below carefully. This must be done with each transplanter.

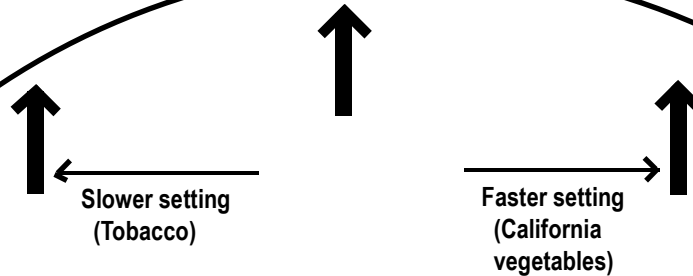

### Timing Instructions for the Model 5000WD

1. Locate the timing arrows on this guard.
2. To insure that each unit is in time, follow these steps (this must be done for each unit separately).
  - a. Observe the keyway on the shaft located in the open hole on this guard.
  - b. Turn the drive wheel slowly until the keyway is at the 12 o'clock position and the arrow is pointing at it. Keyway must remain at the 12 o'clock position while adjusting the cups.
  - c. If the center arrow is pointing at the center of the bottom of any of the 6 cups, your unit is in time for approximately 80-100 plants per minute.
  - e. The cups are adjustable from the center arrow for slower or faster planting speeds.
3. Follow these steps if the timing must be adjusted:
  - a. Loosen the 1/2" bolt at the top of the six cup feeder head.
  - b. Remember to keep the keyway at the 12 o'clock position.
  - c. Rotate the six cup feeder head to your desired position from the center arrow.
  - d. Tighten the 1/2" bolt and proceed.

Keyway in shaft



## B. Sizing cell to shoe

1. Take a cell and place into the rear of the shoe.
2. Using a 15/16" wrench, adjust the bolt on the outside of the shoe to widen or narrow the shoe.  
Cell must fit snugly, stopping near bottom of shoe.

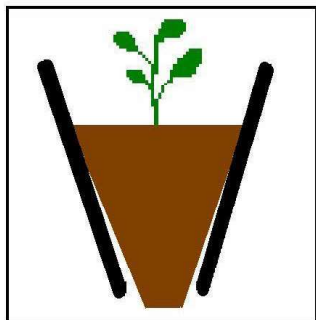

**Incorrect**  
- Narrow the shoe  
with adjustment  
bolt.

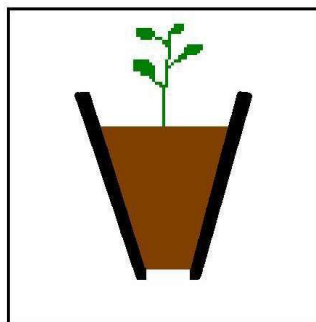

**Correct**

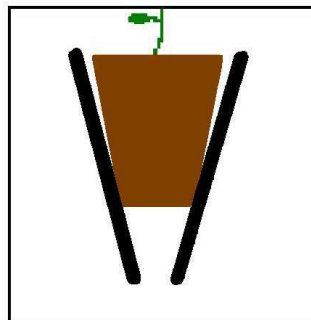

**Incorrect**  
- Widen the shoe  
with adjustment  
bolt.

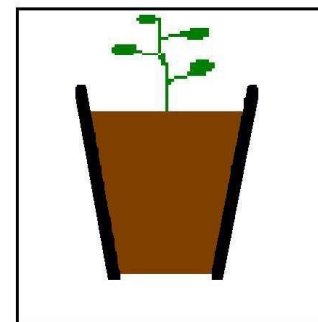

**Correct**

## C. Direct Drive Float Wheel Operaton

1. Only use 4 to 5 pounds of air pressure into the Direct Drive Wheel during operation.



2. It is very important when starting to transplant, that the lift chains on the side of the Direct Drive Wheel are loose. Note above correct picture.
3. When lowering the transplanting unit into the ground, be sure that hte frame members on the Direct Drive Wheel run parallel as is shown in the above set of pictures. This is adjusted by the height of the hitch or toolbar (a pair of gauge wheels will eliminate ad justment of toolbar height).
4. Running the frame parallel will keep the lift chains loose allowing for proper floatation in the Direct Drive Wheel.
5. Running the frame members parallel and level will allow the packing wheels to run in the proper packing position.
6. Running the toolbar too low will tighten the back chains and cause the packing wheels to run too light and not pack the soil properly.
7. Running the toolbar too high will tighten the front lift chains and cause the drive wheel to not run on the ground especially through low spots.

## D. Depth Control and Packing

1. If the depth of the cell planted is incorrect, turn the crank under the seat to set the shoe deeper or shallower.
2. The packing wheels can be adjusted closer together or further apart with the set screws found on the packing wheel hubs.  
Added pressure can be given to the back of the transplanter by lengthening the 3rd arm of the 3-point hitch or shortening the bottom link arms on the pull-type trailer.

## E. Water Valve Adjustment

1. The water valve is set at the factory for maximum stroke.

***Set the ball valve on side of unit for desired amount of water to be released with each plant.***

2. If a smaller stroke is desired, remove the inspection plate in front of the gearbox.  
Raise the #5199 channel on the pump rod to decrease the stroke.  
***Do not over or under stroke valve or it will lock up the unit.***
3. Water placement can be adjusted to trip earlier or later than its current set position. To adjust, loosen the thumb screw on the dial located on the side of the transplanter. Start from the center position and move the dial in small increments. Turning the dial clockwise will cause the water to drop earlier and turning the dial counter-clockwise will cause it to drop later.
4. Drain the water out of the valve at the end of the season or the valve could freeze and be damaged.

## Service

Attention: Care should be taken while servicing the unit because of the bolt together construction of the main frame. NEVER remove the unit top plate, backplate, or shoe at the same time. Frame alignment could be jeopardized if this is done!

A. Resetting the transplanter to factory timing. See page 8.

B. Replacing the Shoe

1. Loosen and remove the two 3/8" bolts going into the bottom of the framework at the back of the shoe.
2. Remove the 3/8" bolt from the front of the shoe.

C. Kicker spring replacement

1. Remove any plant racks or carousel tray holders
2. Loosen the four bolts holding the back plate on
3. Remove the back plate for easy access inside the transplanter

## ***Machine Improvements***

***Mechanical Transplanter Co. is always striving to make improvements on their line of equipment. Mechanical Transplanter Co. reserves the right to make improvements and changes at any time without incurring obligations to make such changes or additions to equipment previously sold.***

# TROUBLE SHOOTING

**Reminder:** Cell-type setters, such as the Model 5000WD, require a firm, rootbound, and moist cell for consistent planting. A poor quality cell directly affects the performance of the transplanter.

| <b>PROBLEM</b>                             | <b>CAUSE</b>  | <b>SOLUTION</b>   |
|--|---|---|
| Plants fall on kicker                      | Machine is out of time<br><br>Poor cell quality and/or dry cells          | Review decal on side of transplanter or see page 10 in the manual<br>Water cells lightly to help them drop faster |
| Plants are buried or lying top of the soil | The furrow opening shoe is not adjusted properly<br><br>Poor cell quality | See the diagram on page 11 of this manual<br><br>Make sure the cells are fully intact when removing from the tray |
| Furrow is not filling in properly          | Furrow sides of opening shoe have built up<br><br>Use as last resort      | Clean shoe with putty knife.<br><br>Rototill soil.  |
| Plants are being flooded out of shoe       | Ball valve on side of transplanter opened too much                        | Close ball valve until proper water flow is achieved  |

# Parts Bag For 5000WD

- 4 - 1/2 x 1-1/4 Hex Bolt
- 3 - 1/2 x 1-1/2 Carriage Bolt
- 1- 1/2 x 2 Hex Bolt
- 1 - #15 Clip Pin
- 8 - 1/2 Nut
- 5 - 1/2 Washer
- 1 - #40 x 110 Chain
- 2 - #43 Bushing
- 1 - Chain Tightener
- 2 - 3/4 Machinery Bushing
- 1 - #373 Spring
- 1 - 5/16 X 1/2" bolt with washer

## In Box

- 1 - #726 Seat Brace
- 1 - Chain Guard
- 1 - Seat Brace Plate
- 1 - Parts Bag

## Spacing Charts

| Model 5000WD Narrow Spacing Chart<br>18 Tooth on Drive Wheel |                           |       |       |       |       |
|--|---------------------------|-------|-------|-------|-------|
| Metal Plate<br>Sprocket                                      | Plastic Spacing Sprockets |       |       |       |       |
|  | 7                         | 8     | 9     | 10    | 11    |
| 38   | 7"                        | 8.5"  | 9.5"  | 10"   | 11"   |
| 32   | 9"                        | 10"   | 12"   | 13"   | 14"   |
| 27   | 11"                       | 12.5" | 13.5" | 15"   | 16.5" |
| 24   | 12"                       | 13"   | 14"   | 17"   | 19"   |
| 18   | 16"                       | 17.5" | 20"   | 22.5" | 26"   |

| Model 5000WD Wide Spacing Chart<br>11 Tooth on Drive Wheel |                           |       |     |       |
|--|---------------------------|-------|-----|-------|
| Metal Plate<br>Sprocket                                    | Plastic Spacing Sprockets |       |     |       |
|  | 7                         | 8     | 9   | 10    |
| 18   | 24"                       | 28.5" | 32" | 35"   |
| 20   | 22.5"                     | 26"   | 28" | 31.5" |
| 22   | 21"                       | 23"   | 26" | 30"   |
| 24   | 19"                       | 21"   | 24" | 27"   |
| 26   | 16.5"                     | 20"   | 22" | 24.5" |

# Safety Precautions

1. Make sure tractor is stopped and in neutral with the transplanter lowered to the ground before getting on and off the unit.
2. No operator is allowed to be on the unit as it is raised and lowered.
3. No operator is allowed on the transplanter as it is transported to or from the field.
4. All operators must be seated before movement begins and remain seated until the transplanter is completely stopped.
5. Never leave the transplanter in the raised position.
6. Keep all shields and guards in place when operating the transplanter.
7. Never attempt repairs or maintenance while the transplanter is in motion.
8. Never put the tractor in reverse while the transplanter is on the ground.
9. Follow all safety instructions supplied by the tractor manufacturer to which the transplanter is mounted.

## **MACHINE IMPROVEMENTS**

*MECHANICAL TRANSPLANTER CO. IS ALWAYS STRIVING TO MAKE IMPROVEMENTS ON THEIR LINE OF EQUIPMENT. MECHANICAL TRANSPLANTER CO. RESERVES THE RIGHT TO MAKE IMPROVEMENTS AND CHANGES AT ANY TIME WITHOUT INCURRING OBLIGATIONS TO MAKE SUCH CHANGES OR ADDITIONS TO EQUIPMENT PREVIOUSLY SOLD.*

## **Limited Warranty**

Mechanical Transplanter Company warrants each item of new equipment manufactured by Mechanical to be free from defects in material and workmanship under normal use and service.

The obligation of Mechanical Transplanter Company under this LIMITED WARRANTY is limited to repairing or replacing as Mechanical may elect, and any parts that prove, in Mechanical's judgment, to be defective in material and workmanship within the first season's use or 45 consecutive days after initially placing equipment in operation, whichever occurs first. Any outside work or alterations without Mechanical's written approval will render the LIMITED WARRANTY void.

Mechanical's obligation specifically excludes any liability for consequential damages, such as loss of profits, delays, expenses, damage to goods or property used in connection with or processed in or by the product sold, or damage to the product sold from whatsoever cause, whether or not such loss is due to negligence of selling dealer of Mechanical Transplanter Company.

This limited warranty shall not apply to any item or machine which shall have been operated in a manner not recommended by the Company nor which shall have been repaired, altered, misused, damaged in an accident, neglected, tampered with or used in any way which in the Company's opinion adversely affects its performance and results.

No person is authorized to give any other warranties or to assume any other liability on behalf of Mechanical Transplanter Company, unless made in writing by Mechanical.

This limited warranty covers repair or replacement of Mechanical Transplanter Co. equipment only and does not cover crop loss, downtime, labor, damage to other equipment, etc.

This limited warranty does not apply to exterior finishes, tires, chain links, bearings, or any other items sold by Mechanical Transplanter Co., but warranted by the original manufacturer except to the extent of their individual manufacturer's warranty.

THIS LIMITED WARRANTY IS IN LIEU OF ALL OTHER WARRANTIES, EXPRESSED OR IMPLIED. WARRANTIES OF MERCHANT ABILITY AND FITNESS FOR PARTICULAR PURPOSE ARE EXCLUDED, AS ARE ALL OTHER REPRESENTATIONS TO THE USER-PURCHASER, AND ALL OTHER OBLIGATIONS OR LIABILITIES, INCLUDING LIABILITY FOR INCIDENTAL AND CONSEQUENTIAL DAMAGES, ON THE PART OF MECHANICAL OR THE SELLER.

**Mechanical Transplanter Company \* 1150 Central Avenue \* Holland, MI 49423**

**Phone: 616-396-8738 or Fax: 616-396-3619**

**website: [www.mechanicaltransplanter.com](http://www.mechanicaltransplanter.com) \* e-mail: [mtc@mechanicaltransplanter.com](mailto:mtc@mechanicaltransplanter.com)**