

*Mechanical  
Transplanter's  
Models 4000 and  
6000 Assembly  
and Operation  
Manual*

## Model 4000 and 6000 Direct Drive Assembly Instructions

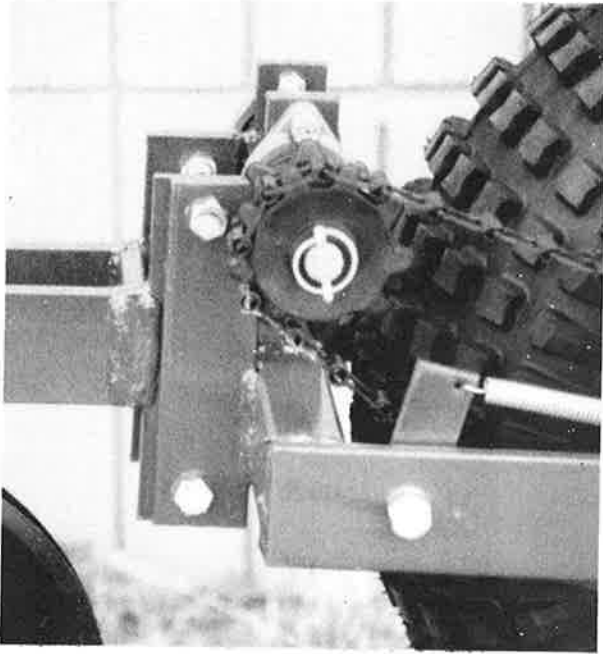

1. Bolt the direct drive wheel to the two hole brackets on the unit frame. Use four 1/2" x 1-1/2" bolts and hex nuts.

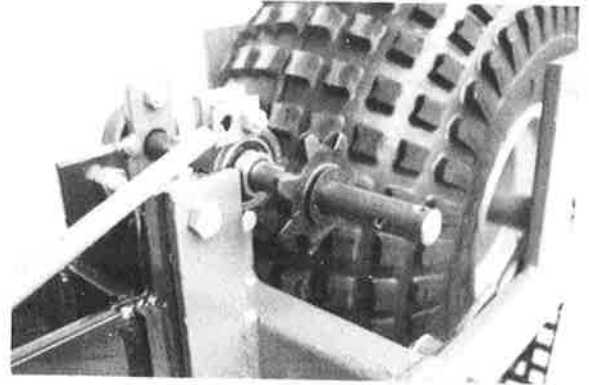

2. Remove the following parts from the direct drive jackshaft: the outside sprocket, shear pin, and pipe spacer.
3. Look at the spacing chart on the chain guard or on Page 17 for the desired in row spacing. Place the proper sprocket on the inside of the direct drive jackshaft and on the shaft by the large spur gear.

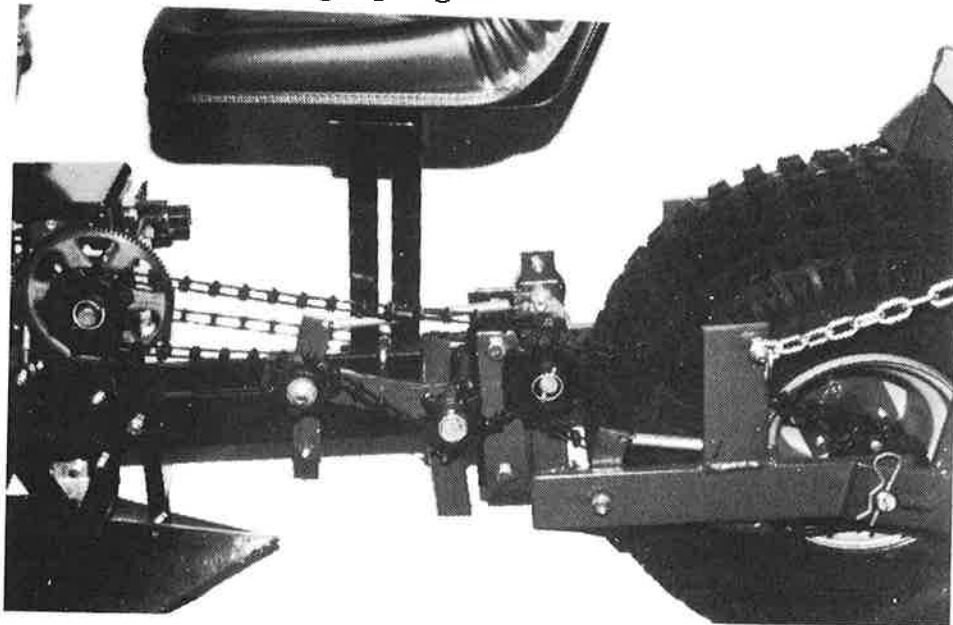

4. Connect the chain from the gear on the spur gear to the gear on the inside of the jackshaft. This chain must go over the first tightener sprocket and under the tightener sprocket on the arm.
5. Put the pipe spacer back on, the shear pin back in the second hole on the jackshaft and the desired spacing sprocket over the shear pin.
6. Connect the chain from the direct drive wheel to the outside jackshaft sprocket.

7. Attach the green L-shaped seat brace to the side of the unit. Bolt the seat brace to the side opposite the chain. Use the 1/2" U-bolt from the inside of the frame going out through seat brace. Secure with 1/2" washers and hex nuts. The L-shaped seat brace must be placed at its highest point. Also after the seat is attached, move the seat as close to the metering top as possible for the best operation of the transplanter.

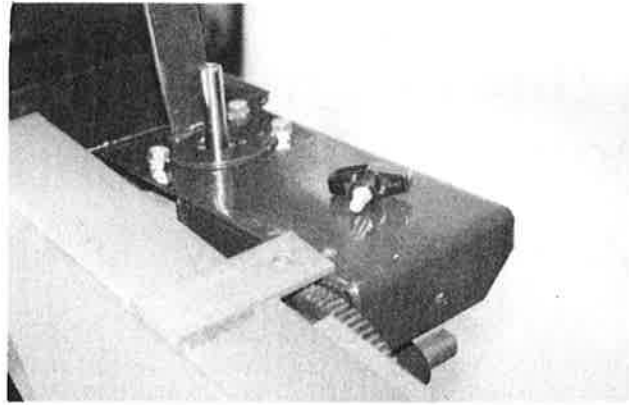

8. Install the chain guard over the chain and gears. Secure on top using the T-bolt.
9. Fasten the foot rest to the frame using two 5/16" J-bolts. The J-bolts attach from the inside, going under the frame.

# **STOP!**

If this unit is a Model 4000B 3 or Model 6000B 3, please continue. Also, all Model 4000 2 and Model 6000 2 with tanks on the toolbar must continue.

All other single row or multi-row units go to  
Page 10.

# Assembly Instructions for 4000B 3 and 6000B 3 Clamps

Model 4000 2 and Model 6000 2 clamps also with tanks on the toolbar

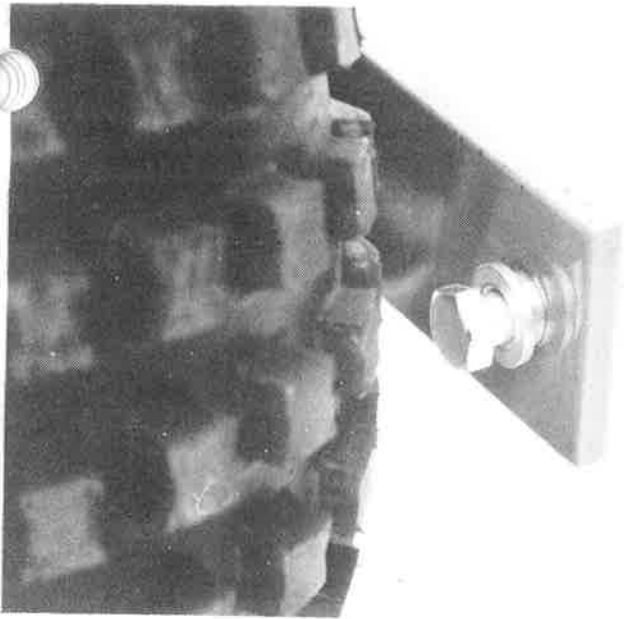

1. Insert the metal bushing from inside of the frame. Put the 1/2 x 1-1/2" bolt through the bushing from the inside of the frame.

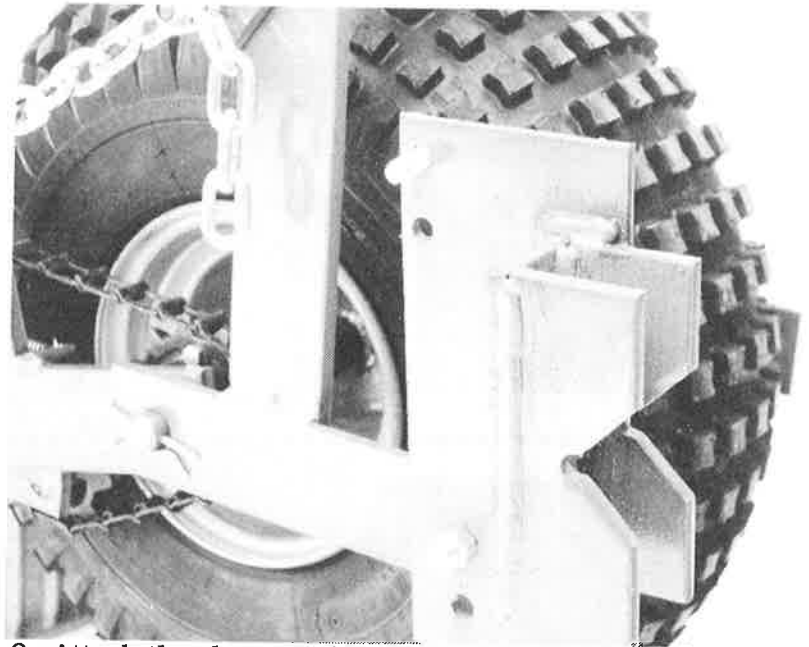

2. Attach the clamp to the bolt through the **top** hole in the bottom of the clamp. Secure with a 1/2" hex nut.

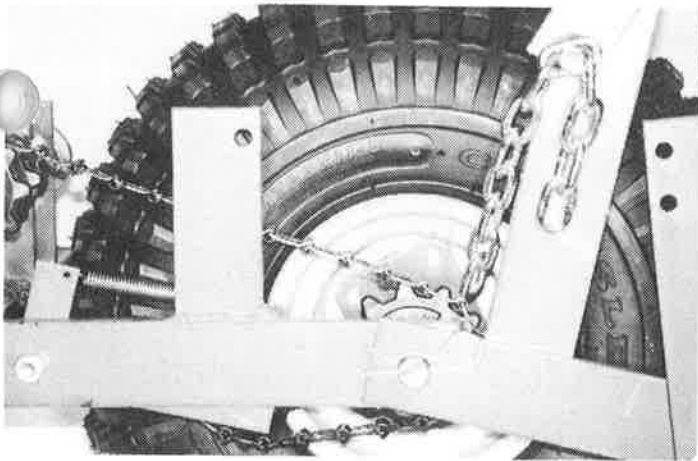

3. Remove the 7/16" x 1-1/4" bolt on your direct drive wheel from one side only. This will make your lift chains hang loose.



4. Locate the special 2-1/2" stud in your bag of bolts and nuts in the clamp box.
5. Turn a 7/16" hex nut on this stud all the way. Next, put on the washer that is included.
6. The lift chain goes on last up against the washer.
7. Put the stud through the hole on the direct drive frame and secure with a 7/16" hex nut.

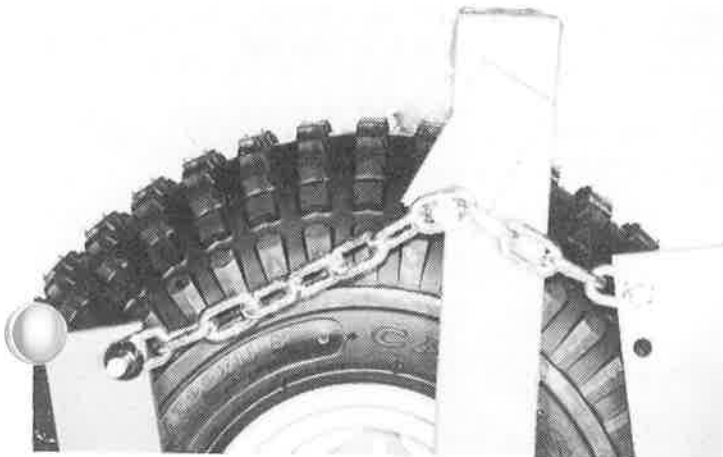

8. Assemble another stud the same way and fasten it to the **top** hole of the direct drive clamp.

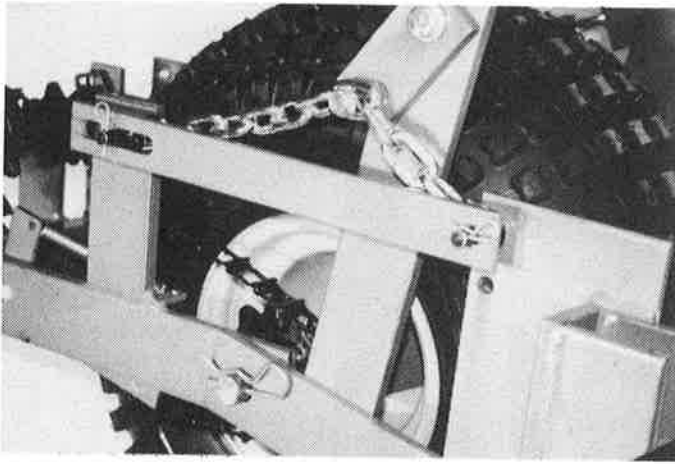

9. Attach the red seat protector to the stud on your drive wheel. The end with the hole **must go on the clamp**. The slotted end **must go on the frame**. After the protector is attached, place the small clip pins through the small holes.

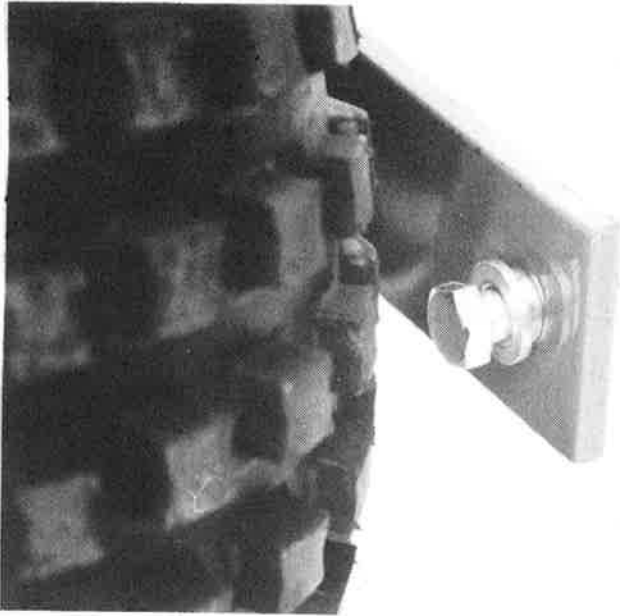

**The other direct drive clamp on the opposite side is installed very similarly.**

1. Insert a metal bushing from inside of the direct drive frame. Put a  $1/2 \times 1-1/2$  bolt through the bushing from the inside of the frame.

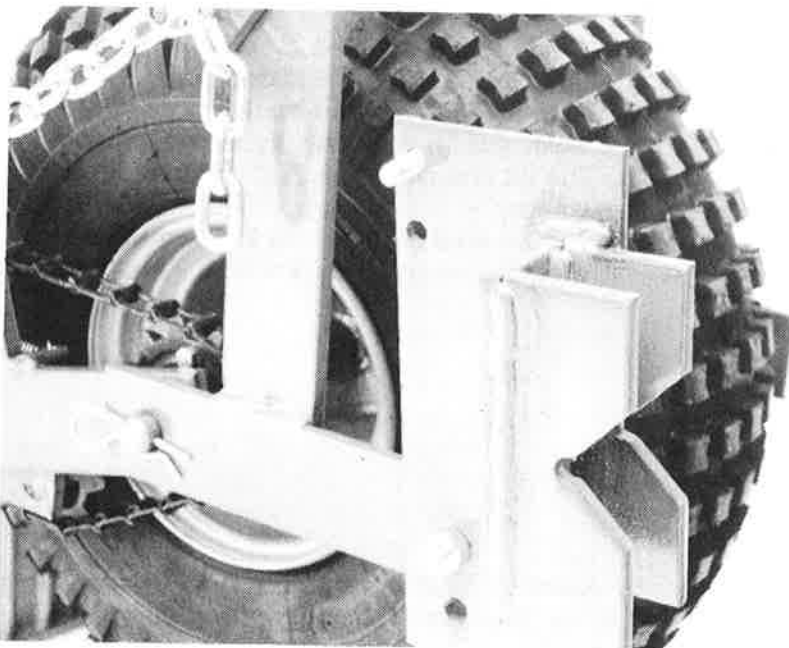

2. Attach the direct drive clamp to the bolt in the **top** hole of the bottom set of holes. Secure with a  $1/2$ " hex nut.
3. Put a  $7/16$ "  $\times$   $1-1/4$ " bolt through the **top** hole of the set of smaller holes.

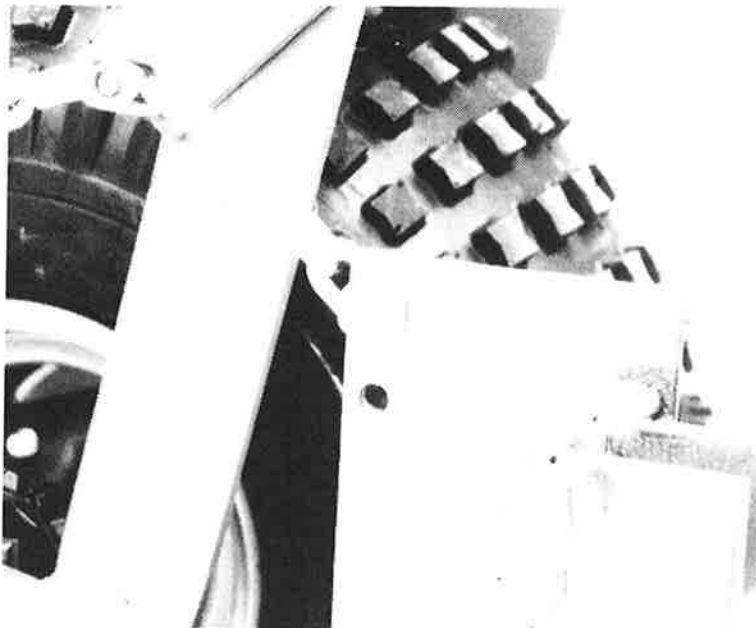
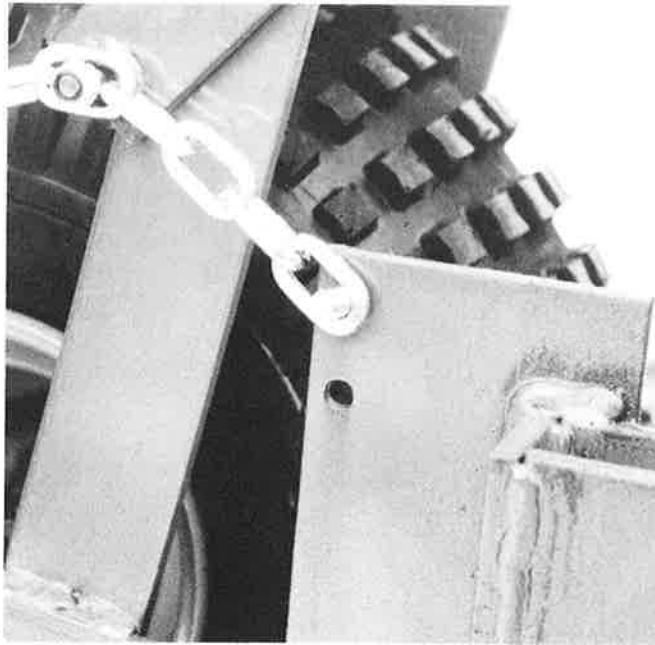

4. Connect the end chain link to the bolt. Secure the chain link, with a 3/8" washer and a 7/16" hex nut.

**Note:** The clamps may be reversed and fastened on the inside of the frame for narrow row spacings. Also, if other clamps are in the way, two lefts or two rights may be used. The lower holes on the clamps are for higher toolbars on older model multi-row frames.

**Note:** On row spacings when the direct drive clamps may hit the clamps on the A-frame, an optional set-ahead toolbar system is available to help get the clamps in the correct position.

## Models 4000 & 6000 Barrel Mounting and 3-Point Hitch Instructions

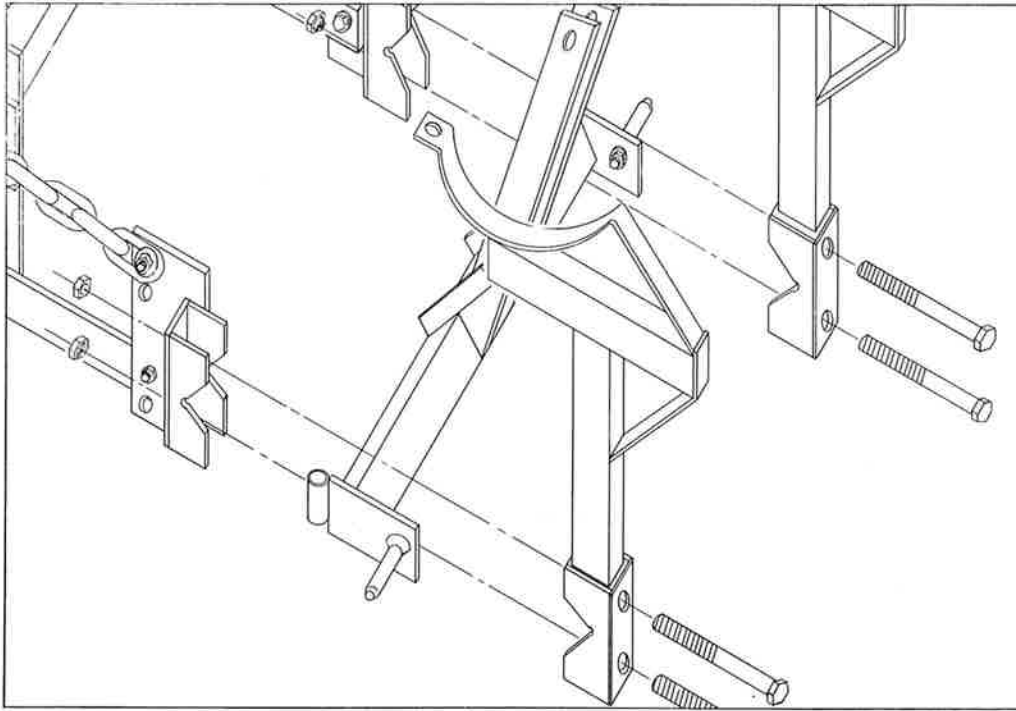

1. On the 3-point hitch, connect the Category I hitch pins through the holes on the outside of the hitch. Put the pins in through the outside and secure with the lock washer and hex nut included with the pin.
2. Put the green pipe stands up through the pipes on the hitch. These can be tightened by turning the set screw.

**Note:** The following instructions will be easier using two people.

3. Center the 3-point hitch toolbar with the clamps on your transplanter. Next, line up one of the barrel mounting brackets with the direct drive clamps. Secure using two 1 x 8-1/2 bolts and hex nuts. Do the same with the other barrel mounting bracket.
4. The 60 gallon poly tank can now be mounted on top of the barrel mountings. Use the four J-bolts and the galvanized straps to secure the barrel to the mountings. Be sure to follow all filling instructions on your tank before tightening the tank fully.
5. Screw in the nipple to the bottom of the tank.
6. Connect the water hose from the tank nipple to the water valve. Secure with hose clamps.



## Instructions for Models 4000 & 6000 Direct Drive Clamps

The following instructions are for mounting the direct drive clamps to your Models 4000 and 6000 units.

Although the pictures show the 2-1/2" clamps, use these instructions for any clamp that is available. They all mount the same way.

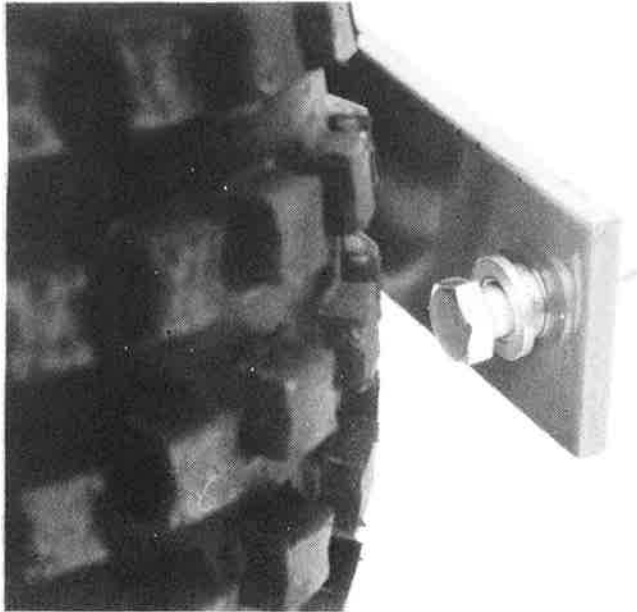

1. Insert a metal bushing from the inside of the frame. Put one of the 1/2" x 1-1/2" bolts through the bushing also from the inside.

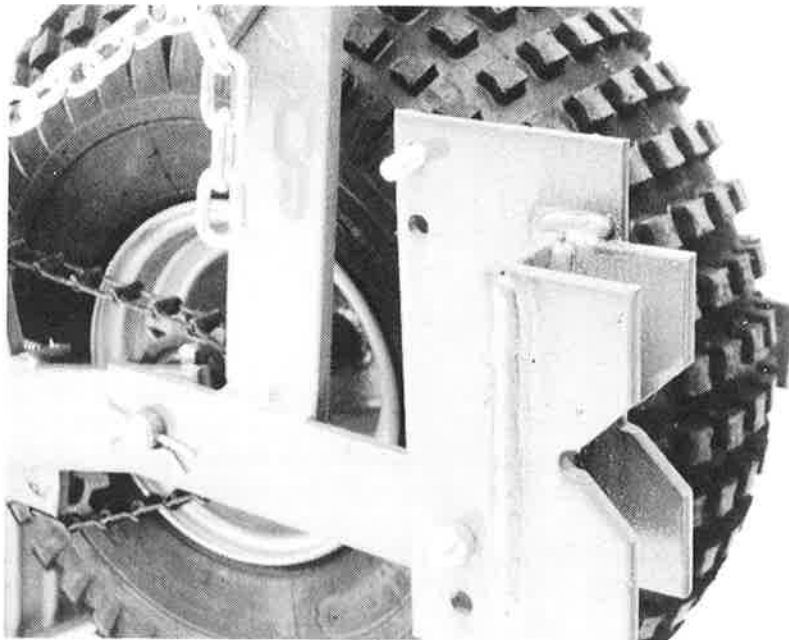

2. Attach the clamp to the bolt in the **top** hole of the bottom set of large holes. Secure with a 1/2" hex nut.
3. In the top set of holes, place a 7/16" x 1-1/4" bolt through the **top** hole.

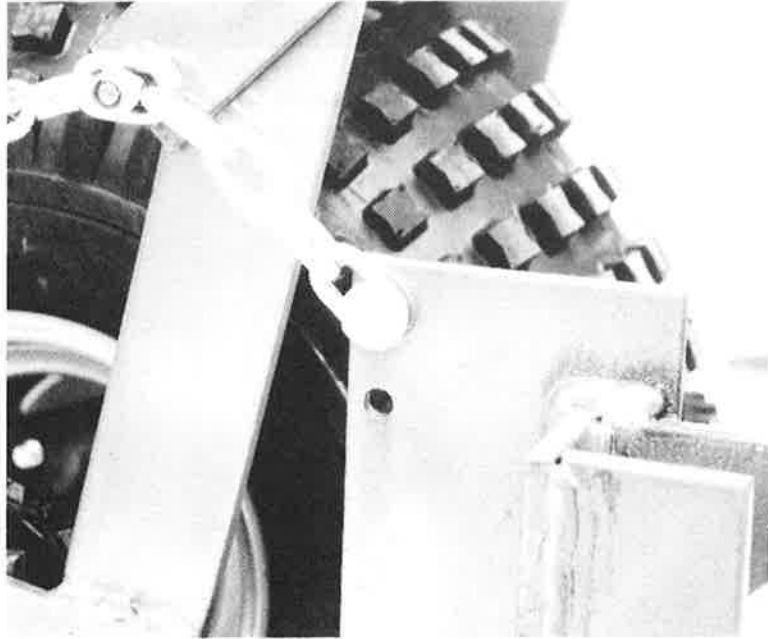

4. Connect the end link of the chain to the bolt.
5. Secure the chain with a 3/8" washer and then a 7/16" hex nut. Make sure the nut is very tight.
6. Use the same instructions for the other side of the direct drive wheel.

**Note:** The clamps may be reversed or fastened on the inside of the frame for narrow row spacings. Also, if other clamps are in the way, two lefts or two rights may be used. The lower holes on the clamps are for higher toolbars on older models.

The Models 4000 and 6000 units can now be mounted to your 3 point hitch or toolbar. The following is a list of fasteners that you must use for various toolbars.

- Single row - 7/8" V-bend U-Bolt (2)
- 2-1/2" or 2-1/4" Diamond toolbar - 7/8" V-bend U-bolt (2)
- 3" x 3" Flat Toolbar - 3/4" x 5" Hex bolts (4)
- 4" x 4" Flat Toolbar - 3/4" x 6" Hex bolts (4)
- 4" x 7" Toolbar - 3/4" x 6" Hex bolts (4)
- 5" x 7" Toolbar - 3/4" x 7" Hex bolts (4)

No matter what size toolbar you may have, Mechanical Transplanter will make sure that you have the right clamps. Dealer or customer should notify us as to which type of toolbar clamps are needed if not ordering the toolbar from us.

## Mounting your Fiberglass or Cushion Seat

### •Fiberglass Seats•

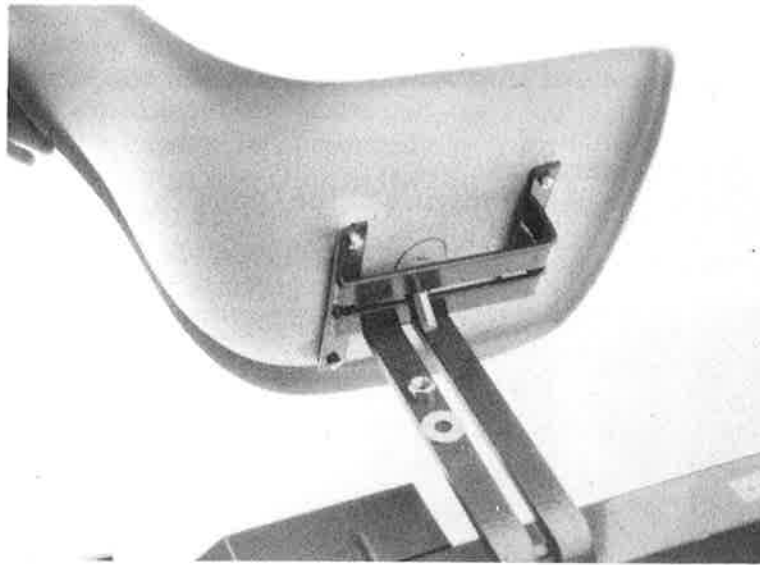

**Fiberglass Seat** - Turn your fiberglass seat over and remove any plastic covers over the threaded studs. Take your green fiberglass seat bracket and mount it to the bottom of the seat with the side with the bend towards the front of the seat. Secure with four 1/4" hex nuts. Put the 1/2 x 1-1/2 carriage bolt through the brace and then through the L-shaped seat bracket. Secure with a 1/2" washer and hex nut.

### •Cushion Seats•

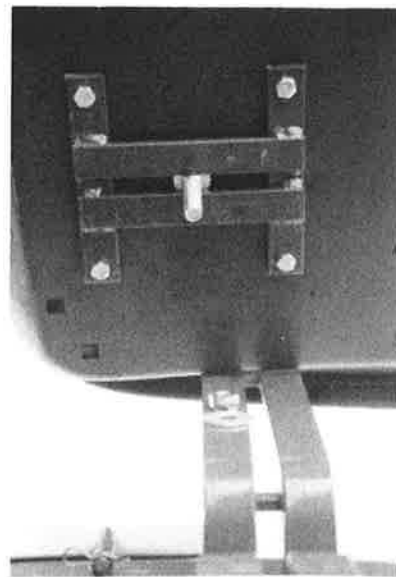

**Cushion Seat** - Put the 1/2" x 1-1/2" carriage bolt through the bottom of the green seat bracket before mounting the seat bracket to the seat. After placing the carriage bolt through the seat bracket, place the seat bracket on the cushion seat. Secure with four 5/16" x 1/2" hex head bolts. Place the seat on the L-shaped seat bracket and secure with a 1/2" washer and hex nut.

# Operating Instructions

## A. Grease Fittings

1. It is very important to grease the machine each time before using it.
2. Grease fittings are located under the timing plate. Also, a grease fitting is on the Direct Drive Wheel hub.
3. Oilite bearings are in the packing wheels, in the kicker mechanism and in the Direct Drive Wheel Hub.

## B. Direct Drive Float Wheel Operation

1. Only use 4 to 5 pounds of air pressure in the Direct Drive Wheel during operation.



Wrong



Correct



Wrong

2. It is very important when starting to transplant, that the lift chains on the side of the Direct Drive Wheel are loose. Notice the above pictures.
3. When lowering the transplanting unit into the ground, be sure that the frame members on the Direct Drive Wheel run parallel as is shown in the above set of pictures. This is adjusted by the height of the hitch or toolbar.
4. Running the frame parallel will keep the lift chains loose allowing for proper floatation in the Direct Drive Wheel.
5. Running the frame members parallel and level will allow the packing wheels to run in the proper packing position.
6. Running the toolbar too low will tighten the back chains and cause the packing wheels to run too light and not pack the soil properly.

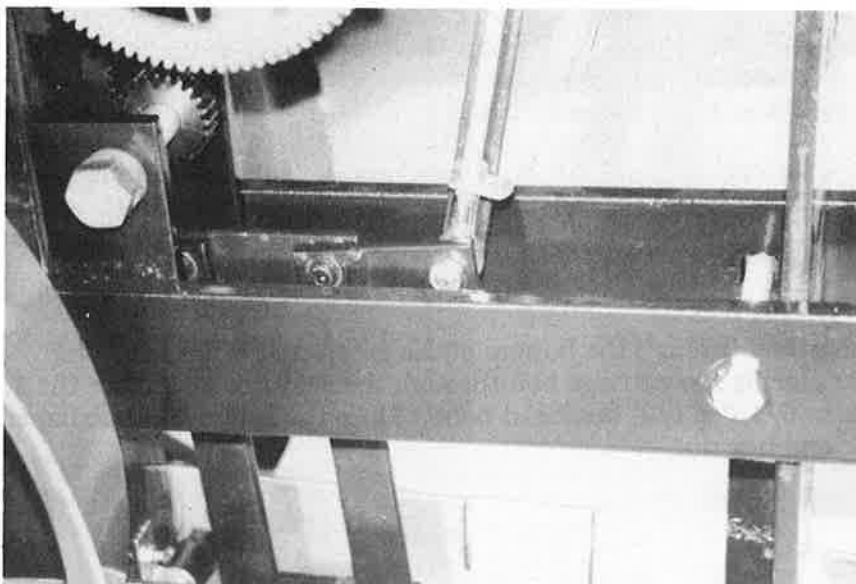

7. Running the toolbar too high will tighten the front lift chains and cause the drive wheel to not run on the ground especially through low spots.

## C. Adjusting the Depth

Loosen the 7/16" carriage bolt just behind the front shoe support. Now loosen the large 5/8" nut on the bolt with the small spur gear that goes on through the frame. Turn the head of the large bolt to raise or lower the metering unit on the rack and pinion gear. **Make sure the front shoe brace slides freely between the frame members.** After the desired setting is achieved tighten the 5/8" nut and 7/16" carriage bolt again.

#### D. Timing of the Transplanter

1. The Model 4000 and Model 6000 are shipped from the factory pretimed for approximately 58 to 64 plants per minute.
2. If planting at about one plant every second, the timing will not have to be changed.
3. Make a starting point in the soil and count for 15 seconds. If you set 15 plants, you should be right on. Be sure not to start out too slowly. The timing is set for at least one plant per second. Watch your tractor RPM carefully. This is the only thing that can change the timing to faster or slower speeds.
4. There is an easy way to see if your unit is in time. To find the correct starting point for timing, start by the kicker. Make sure the kicker is at its full stroke. This occurs when the kicker drive arm is all the way down and sitting straight with the threaded rod. When this has been achieved, look at the cups. If they are sitting square with the droptube, your machine is in time and ready to plant. If your

cups are not square, loosen the long set screw under the top only. Now turn the top to square it with the droptube. The timing is set and you can start transplanting.

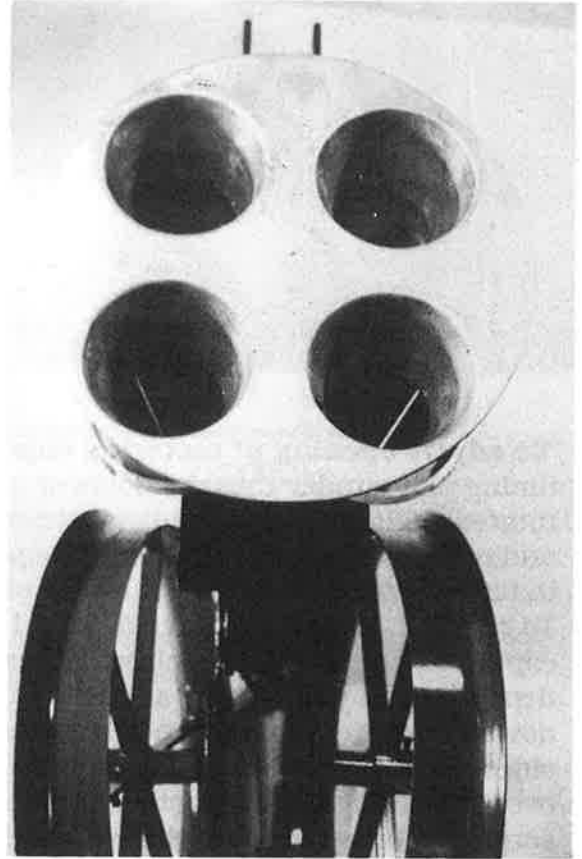
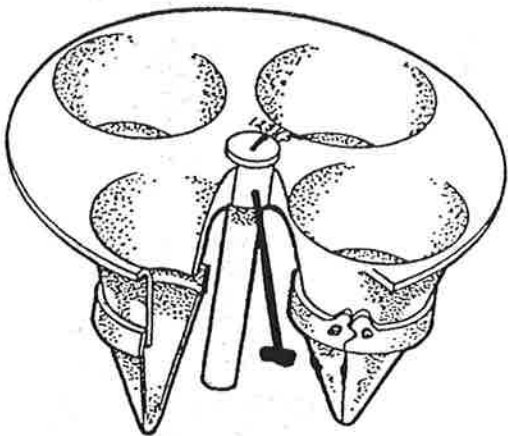

**E. Adjusting the kicker:** The kicker must come out about 1/8" beyond the edge of the shoe. To adjust it in or out remove the bolt from the kicker drive arm and turn the ball joint in or out of the threaded rod to get the proper adjustment.

**F. To change or advance timing** (for units after 1989): To change the timing is an easy process and can be done in seconds. If, as you go faster, your plants drop on top or bump the kicker, then you have to **ADVANCE THE TIMING** of the kicker. To do this, loosen the long 5/16" bolt under the metering wheel top, and rotate the top **CLOCKWISE**. **ON A MODEL 4000 THIS WILL BE TOWARD A LOWER NUMBER.** **ON A MODEL 6000 CLOCKWISE WILL BE TOWARDS A HIGHER NUMBER** on the numbers that the plastic cap points too. Reverse this to retard the timing. You only have to turn the top slightly to advance it.

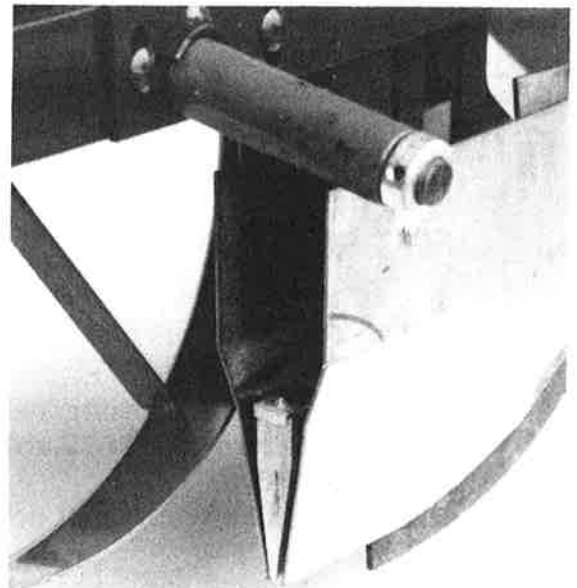

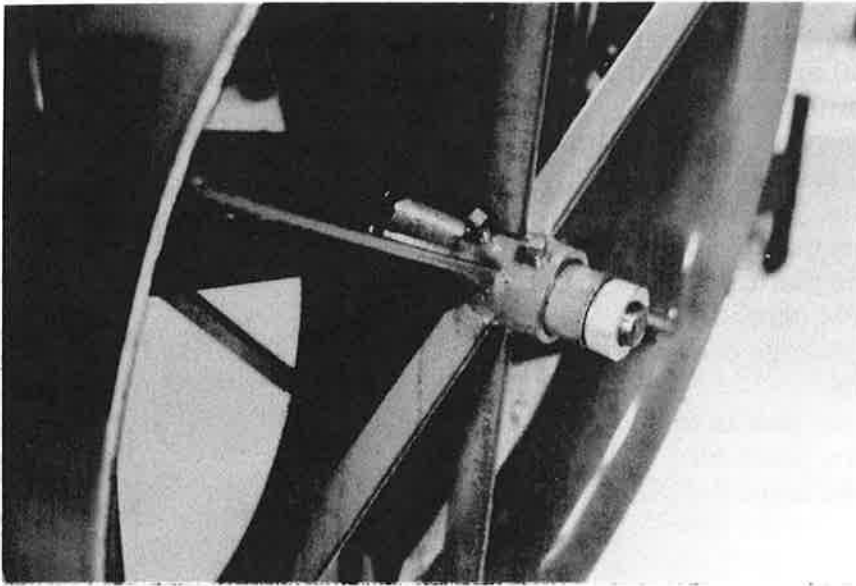

**G. Adjust packing wheels** in or out as you raise or lower the metering unit in the frame. Keep the wheels **AS CLOSE TO THE SHOE AS POSSIBLE**. The wheels are mounted on adjustable hubs. Just loosen set screws and move wheel.

**H. To adjust opening of metering cups:** The upright timing plate under the trap doors or cups can be rotated slightly clockwise to make them open sooner and counter clockwise to delay the opening. We like to have them open right at the edge of the drop tube. To rotate it, loosen the three 5/16 x 1/2" hex head cap screws on the timing plate. Adjust carefully depending on your speed, as the plants should drop down the center of the drop tube without hitting the sides. Make sure the rollers on the cups roll up and over the timing plate smoothly. Make sure the set screw on the center post clears the upright.

**I. Keep the cells wet at all times** for added weight to speed drop time.

**J. Keep the shoe clean inside and out.** This will help keep the furrow narrow and will help eliminate shear pin breakage.

**K. Shear Pins**

1. A shear pin is located in the outside sprocket hole of the direct drive jackshaft.
2. Never put any other object in this hole. Putting a hard object in this hole could cause the teeth on the spur gear to break.

**L. Water Valve**

1. Empty the water valve when the planting day is finished. Water freezing inside the water valve will destroy the #612 and #610 balls inside the valve.
2. All water adjustments must be done on the ball valve.
3. The #604 bracket can be raised or lowered to adjust for more or less stroke.

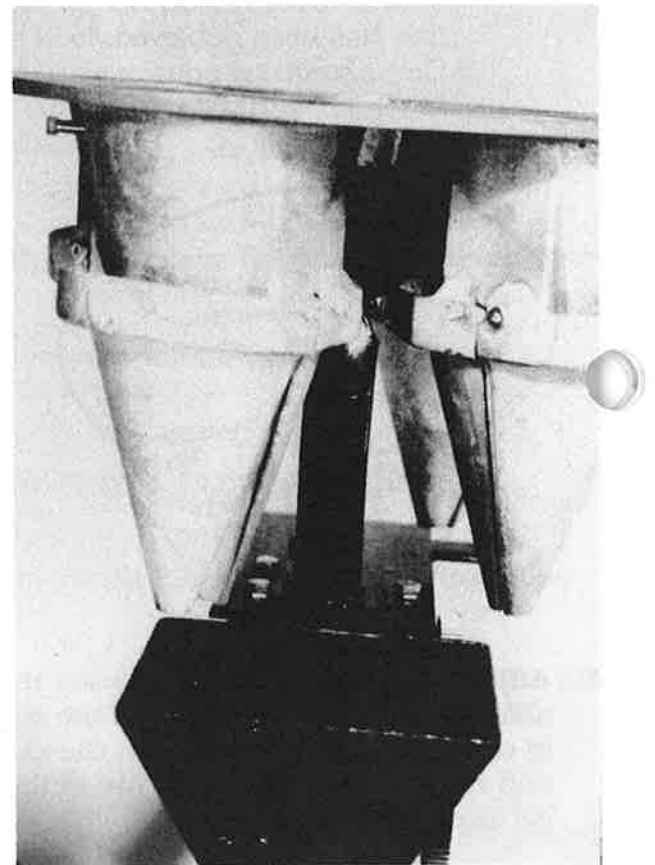

## Model 4000 & 6000 Cell-Shoe Instructions

It is very important with the 4000 and 6000 that the cells fit the shoe. The cell must wedge to the shape of the shoe in order to work properly. Different cell sizes are not a problem as we can fit most any cell size if we know about it when you are ordering.

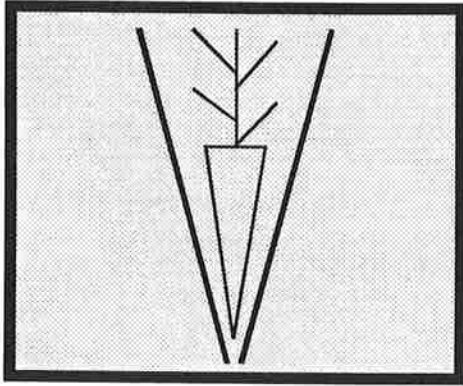

Incorrect

In this example, the plant isn't wedged into the shoe, so the cell could move or fall before the kicker indexes it out of the shoe properly. For instance, the Speedling\* 200 (1" x 3") cell has a more narrow taper than all the rest of their trays. For this cell we simply use a special narrow shoe to allow the cell to fit snug.

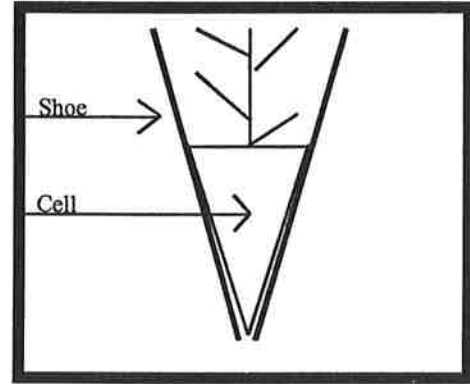

Correct

This illustration shows a perfect fitting cell. It is wedged into the shoe, if only for a second or less, and is stabilized properly so the kicker can index it out into the soil. Perfectly straight and properly spaced.

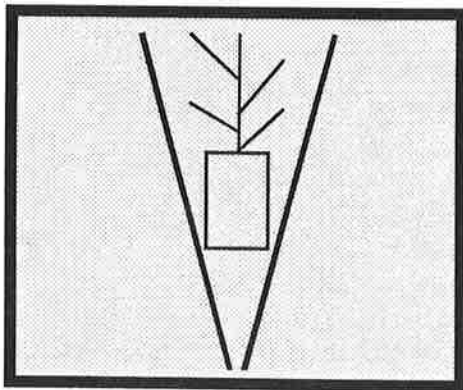

Incorrect

This type of cell isn't tapered and cannot wedge into the bottom of this style shoe. This cell will most likely fall over, or the top of the kicker will come and hit just the bottom of the cell and flip it out on the top of the soil. We can accommodate this type of cell by making a flat bottomed shoe.

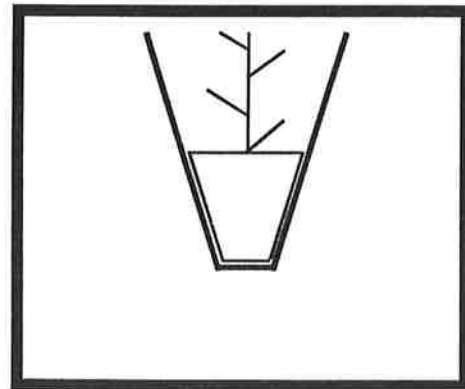

Correct

Even on wider flat bottomed cells, as shown above, they should be allowed to wedge gently into the special wide shoe. This shoe stabilizes the cell and allows for perfect placement and depth control by the kicker and shoe.

\*Registered Trademark

## Special Model 6000 Spacing Charts

## Special Model 4000 Spacing Charts

SPACING CHART FOR MODEL 6000 WITH DIRECT DRIVE AND SPECIAL 9 TOOTH WHEEL SPROCKET						
Sprocket on OUTSIDE of Jackshaft	Sprocket on INSIDE of Jackshaft	Number of Teeth on Sprocket on Unit				
		7	8	9	10	11
7	7	15" 38.1 cm	17" 43.18 cm	19" 48.25 cm	21" 53.34 cm	23" 58.42 cm
8	7	16" 40.64 cm	18" 45.72 cm	21" 53.34 cm	24" 60.96 cm	26" 66.04 cm
9	7	16" 45.72 cm	21" 53.34 cm	24" 60.96 cm	28" 71.12 cm	29" 73.66 cm
10	7	20" 50.8 cm	24" 60.96 cm	28" 71.12 cm	30" 76.2 cm	32" 81.28 cm
11	7	21" 53.34 cm	25" 63.5 cm	29" 73.66 cm	32" 81.28 cm	34" 86.36 cm

Optional 40" Spacing available with the following combination:  
11 Tooth Outside, 6 Tooth Inside, 11 Tooth on Unit.

SPACING CHART FOR MODEL 4000 WITH DIRECT DRIVE AND SPECIAL 14 TOOTH WHEEL SPROCKET						
Sprocket on OUTSIDE of Jackshaft	Sprocket on INSIDE of Jackshaft	Number of Teeth on Sprocket on Unit				
		7	8	9	10	11
7	11	5" 12.7 cm	6" 15.2 cm	7" 17.8 cm	8" 20.3 cm	9" 22.9 cm
7	7	8" 20.3 cm	9" 22.9 cm	10 1/2" 26.7 cm	12" 30.5 cm	13" 33 cm
8	7	10 1/2" 26.7 cm	12" 30.5 cm	13" 33 cm	15" 38.1 cm	16" 40.6 cm
9	7	11" 28 cm	13" 33 cm	14" 35.6 cm	16" 40.6 cm	18" 45.7 cm
10	7	13" 33 cm	15" 38.1 cm	16 1/2" 41.9 cm	18" 45.7 cm	20" 50.8 cm
11	7	13 1/2" 34.4 cm	15 1/2" 39.4 cm	18" 45.7 cm	19 1/2" 49.5 cm	22" 55.8 cm

Spacings may vary slightly due to soil conditions. Make sure the Floating Hitch is parallel to the ground when starting to plant.

MODEL 6000 SPACING CHART						
Roller Chain Sprockets on:		Number of Teeth on Spacing Sprockets				
REAR JACKSHAFT	GEAR BOX	7	8	9	10	11
*14 Tooth	**10 Tooth	9" 22.8 cm	10" 25.4 cm	11" 28 cm	12" 30.5 cm	14" 35.5 cm
*14 Tooth	*14 Tooth	10" 25.4 cm	13" 33 cm	14" 35.5 cm	16" 40.6 cm	17" 43.2 cm
*14 Tooth	**18 Tooth	17" 43.2 cm	19" 48.3 cm	20" 50.8 cm	24" 61 cm	28" 66 cm
*14 Tooth	**24 Tooth	23" 58.4 cm	25" 63.5 cm	28" 71 cm	32" 81.3 cm	34" 86.3 cm

A complete set of Spacing Sprockets shown above comes with each unit.  
\*Standard Roller Chain Sprocket on Unit.  
\*\*Optional Roller Chain Sprockets for additional spacings.  
Optional #6000EJ w/Extra Jackshaft gives additional spacings from 34" to 84".  
Spacings as listed are approximate and will vary with soil conditions.

## Model 4000 Rear Drive Only

MODEL 4000 SPACING CHART						
Roller Chain Sprockets on:		Number of Teeth on Spacing Sprockets				
REAR JACKSHAFT	GEAR BOX	7	8	9	10	11
*22	*10	5 1/2" 13.97 cm	6 1/2" 16.51 cm	7 1/2" 19.05 cm	8 1/2" 21.59 cm	9 1/2" 24.13 cm
14	12	10" 25.40 cm	12" 30.48 cm	13 1/2" 34.29 cm	15" 38.10 cm	16" 40.64 cm
14	*18	15 1/2" 39.37 cm	17 1/2" 44.45 cm	20" 50.80 cm	22" 55.88 cm	23" 58.42 cm
14	*26	23" 58.42 cm	27 1/2" 69.85 cm	30 1/2" 77.47 cm	33 1/2" 85.09 cm	36" 91.44 cm

The 14 tooth sprocket on the jackshaft and 12 tooth on the gear box are STANDARD unless you specify your choice of another range as standard.  
\* = OPTIONAL Sprockets (10, 18, 22 and 26)  
The complete set of Spacing Sprockets shown above come with each unit.

## Standard Model 4000 and 6000 Direct Drive Spacing Chart

SPACING CHART FOR MODEL 4000 & 6000 WITH DIRECT DRIVE						
Sprocket on OUTSIDE of Jackshaft	Sprocket on INSIDE of Jackshaft	Number of Teeth on Sprocket on Unit				
		7	8	9	10	11
7	11	7-1/2" 19 cm	8-1/2" 21.6 cm	10" 25.4 cm	11" 28 cm	12" 30.5 cm
7	7	12" 30.5 cm	13" 33 cm	14" 35.5 cm	15" 38.1 cm	16" 40.6 cm
8	7	13" 33 cm	14-1/2" 36.8 cm	16" 40.6 cm	18" 45.7 cm	20" 50.8 cm
9	7	15" 38.1 cm	17" 43.2 cm	19" 48.3 cm	22" 55.9 cm	24" 61 cm
10	7	16" 40.6 cm	18-1/2" 47 cm	21" 53.3 cm	24" 61 cm	26" 66 cm
11	7	19" 48.3 cm	21" 53.3 cm	23" 58.4 cm	26" 66 cm	29" 73.7 cm



# TROUBLE SHOOTING TABLE

**IMPORTANT:** Before attempting any of the following: **MAKE ABSOLUTELY SURE THE UNIT IS RUNNING LEVEL OR PARALLEL TO THE GROUND.** Don't run with the front (hitch end) too far down or up. Make sure you have float in the hitch by lengthening the third arm of your tractor.

Problem	Solution
Plants lay on top of soil	<ol style="list-style-type: none"><li>Timing must be advanced. (See timing instructions)</li><li>If you have water valves, too much water may be applied.</li><li>Lift chains are tight and packing wheels are not packing. (Loosen lift chain)</li></ol>
Shoe fills with dirt	<ol style="list-style-type: none"><li>Ground is too soft allowing the wheels to sink in too deep, causing dirt to build up too high in front of them so they cannot turn evenly.</li><li>Culti-mulch or roll the soil firm. The float wheel assembly mounted in front of the units also takes care of this problem.</li><li>Check for friction. Chains should be lubricated if they are rusty and stiff. Make sure the drive chains from the wheels up to the jackshaft are not too tight. Loosen chain tighteners slightly.</li><li><b>CLEAN SHOES INSIDE AND OUT.</b> Washing works good for insides.</li><li>Keep shields over the spur gears in place. Do not let dirt get in them.</li></ol>
Cups are loose Cups coast forward	<ol style="list-style-type: none"><li>Tighten set screw on the post that holds the cups.</li><li>Keep chain snug or firmly tight from the jackshaft to the gear box. On the rear drive only, keep the <b>NYLON CHAIN TIGHTENER TIGHT!</b> You may have to take a 1/2" link out if chain is too long or stretches.</li></ol>
Plants do not fall in the center of the shoe	<ol style="list-style-type: none"><li>Units are not being run level, making the plants fall to the rear of the shoe or forward onto the kicker.</li><li>Rotate the upright cam under the cups so the plant just starts to drop at the edge of the drop tube.</li></ol>
Small stones get between shoe and kicker	<ol style="list-style-type: none"><li>Ground not firm enough and dirt comes over top of shoe.</li><li>Shoe out of alignment or damaged.</li><li>Make sure the kicker is not indexing more than 1/8" out of the shoe.</li></ol>
Metering unit does not raise or lower easily	Loosen <b>BOTH NUTS!!</b> Read Letter C instructions under operation. Grease spur gear adjustment often.

## Safety Precautions

1. Make sure tractor is stopped and in neutral with the transplanter lowered to the ground before getting on and off the unit.
2. No operator is allowed to be on the unit as it is raised and lowered.
3. No operator is allowed on the transplanter as it is transported to or from the field.
4. All operators must be seated before movement begins and remain seated until the transplanter is completely stopped.
5. Never leave the transplanter in the raised position.
6. Keep all shields and guards in place when operating the transplanter.
7. Never attempt repairs or maintenance while the transplanter is in motion.
8. Never put the tractor in reverse while the transplanter is on the ground.
9. Follow all safety instructions supplied by the tractor manufacturer to which the transplanter is mounted.

### Limited Warranty

Mechanical Transplanter Company warrants each item of new equipment manufactured by Mechanical to be free from defects in material and workmanship under normal use and service.

The obligation of Mechanical Transplanter Company under this LIMITED WARRANTY is limited to repairing or replacing as Mechanical may elect, any parts that prove, in Mechanical's judgment, to be defective in material and workmanship within the first season's use or 45 consecutive days after initially placing equipment in operation, whichever occurs first. Any outside work or alterations without Mechanical's written approval will render the LIMITED WARRANTY void.

Mechanical's obligation specifically excludes any liability for consequential damages, such as loss of profits, delays, expenses, damage to goods or property used in connection with or processed in or by the product sold, or damage to the product sold from whatsoever cause, whether or not such loss is due to negligence of selling dealer of Mechanical Transplanter Company.

This LIMITED WARRANTY shall not apply to any item which has been operated in a manner not recommended by Mechanical.

No person is authorized to give any other warranties or to assume any other liability on behalf of Mechanical Transplanter Company, unless made in writing by Mechanical.

THIS LIMITED WARRANTY IS IN LIEU OF ALL OTHER WARRANTIES, EXPRESSED OR IMPLIED. WARRANTIES OF MERCHANTABILITY AND FITNESS FOR PARTICULAR PURPOSE ARE EXCLUDED, AS ARE ALL OTHER REPRESENTATIONS TO THE USER-PURCHASER, AND ALL OTHER OBLIGATIONS OR LIABILITIES, INCLUDING LIABILITY FOR INCIDENTAL AND CONSEQUENTIAL DAMAGES, ON THE PART OF MECHANICAL OR THE SELLER.

## **Mechanical Transplanter Company**

1150 South Central Avenue • Holland, MI 49423-5230

Phone: 616-396-8738 • Fax 616-396-3619