

Mechanical Transplanter Co. MODEL 1100 Parts List



<u>Part Number</u>	<u>Description:</u>	<u>Part Number</u>	<u>Description:</u>
12	Direct drive tire & rim (22x11x8 knobby)	649NLDD	Left double disc shoe shield
15	Chain guard clip pin	649NR	Right side shoe mount / shield
31	Main frame of rear half	649NRDD	Right double disc shoe shield
32	Wheel chain tightener spring	740	7/8" V-bend U-bolt with nuts
35	1/4 X 15" chain for direct drive	1000SS	Double disc shoe spacer
38	Wheel hub w/sprocket	1925	Chain tightener sprocket only
39	Main frame of front half	4672	1/2 moon woodruff key
40	Left clamp less U-Bolt	4740	Counter balance clip
42	Right clamp less U-Bolt	5019	Mounting bracket
43	Shoulder bushing	5024B	3/4 oilite bearing for scissor hitch
44	Chain lift plate	5031	1/4 X 3/4 flat head stainless steel
47	4 X 7/7 X 7 securing plate	5077	Double sprocket cluster chain - #40 x 80P
48	Left 4x4/4x7 direct drive clamp	5080HX	Double sprocket cluster with 7/8" hex hub
49	Right 4x4/4x7 direct drive clamp	5081HX	Triple sprocket cluster for hex
328	3/4" flange block	5084HX	Hex lower shaft on toolbar drive system
373	Chain tightener spring	5085HX	Hex middle shaft on toolbar drive system
375	Water trip	5089	Chain tightener roller (2" long)
375W	Water trip washer	5113	7/8" hex flange block
376S	Tension spring (10 & 12 pocket)	5149	Pin for mounting front chain guard
377R-555ML	CA555 Connector pin & cotter	5552	20 tooth spacing gear
386	Shaft/Axle/Hitch bar	5553	22 tooth spacing gear
386P	Shaft clip pin	5554	24 tooth spacing gear
395DDS	Double disc shoe with discs (5/8" bearing)	5563-6	Close spacing chain add on - #40 x 6P
395DDSP	Poly double disc shoe with discs (5/8" bearing)	5565	Direct drive mounting plate
395R	7" round point shoe	11100AL	Left hex axle
440	Pocket spring with UHMW rollers	11100AR	Right hex axle
445	Rubber gripper for V-3 pocket	11100PF	1100 frame
450	Pocket main frame	11101	Hex packing wheel bearing
452	Pocket attaching bolt	11102	Packing wheel hub with bearings
4740	Counter balance clip	11105RL	Pair of pocket guides for 1100
529WP	Wide wheel scraper plastic only	11106	Bearing spacer
530	Wheel scraper mounting bracket	11107	Model 1100 spacer between the uprights
639RB	Regular packing wheel for roller bearing sleeve	11108	Upper conveyor sprocket (12T)
649NL	Left side shoe mount/shield		

Continued next page:

Mechanical Transplanter Co.
1150 Central Ave - Holland, MI 49423 * Phone 616-396-8738 * Fax 616-396-3619
Website: www.mechanicaltransplanter.com ~ E-Mail: mtcparts@egl.net

MODEL 1100 Parts Continued

Part Number Description:

11109	Lower conveyor sprocket (10T)
11115	Top sprocket shaft
11116	Lower sprocket jackshaft
11120	1100 Upright lower section
11121	Model 1100 Upright top section
11122	Chain tightener bearing on upright
11123	Model 1100 pocket chain tightener studs
11124	Upright assembly with bearing
11130	Wheel scraper complete
11130L	Left 1100 wheel scraper extension
11130R	Right 1100 wheel scraper extension
11137	16 attachment roller conveyor chain
11138	Lynch pin for 1100/5500 spacing sprockets
11139	Drive pin
11142	15 tooth spacing gear
11144	17 tooth spacing gear
11149	1100ls Unit drive chain - #40 x 146P
11150	Direct drive jackshaft
11151	1100 direct drive guard

Part Number Description:

11152	1100 outside direct drive chain guard
11152LS	Line shaft outside guard
11153	Inside direct drive unit guard
11153LS	Line shaft inside guard
11154	Front line shaft chain guard
11155	1100 Chain tightener arm only
11155WS	Chain tightener arm with sprocket
11156	1100LS Unit Drive Chain - #40 x 194P
11158	Model 1100 chain tightener tension spring
11160	Parallel link - model 1100
11161	1100LS 7/8 Hex-18 tooth sprocket
11180	Sweet potato slip guide
CA-16	Complete 16 pocket chain with water trips
FCK113	1/4 X 1-1/2 cotter key
FMB500	7/8" 14 ga. machinery bushing
OE61RB	Rubber packing wheel for roller bearing
SP-16	Pocket spacer 16 pocket roller chain
V-3D	Pocket complete less separating bar

1100 / 1100LS UNIT PARTS

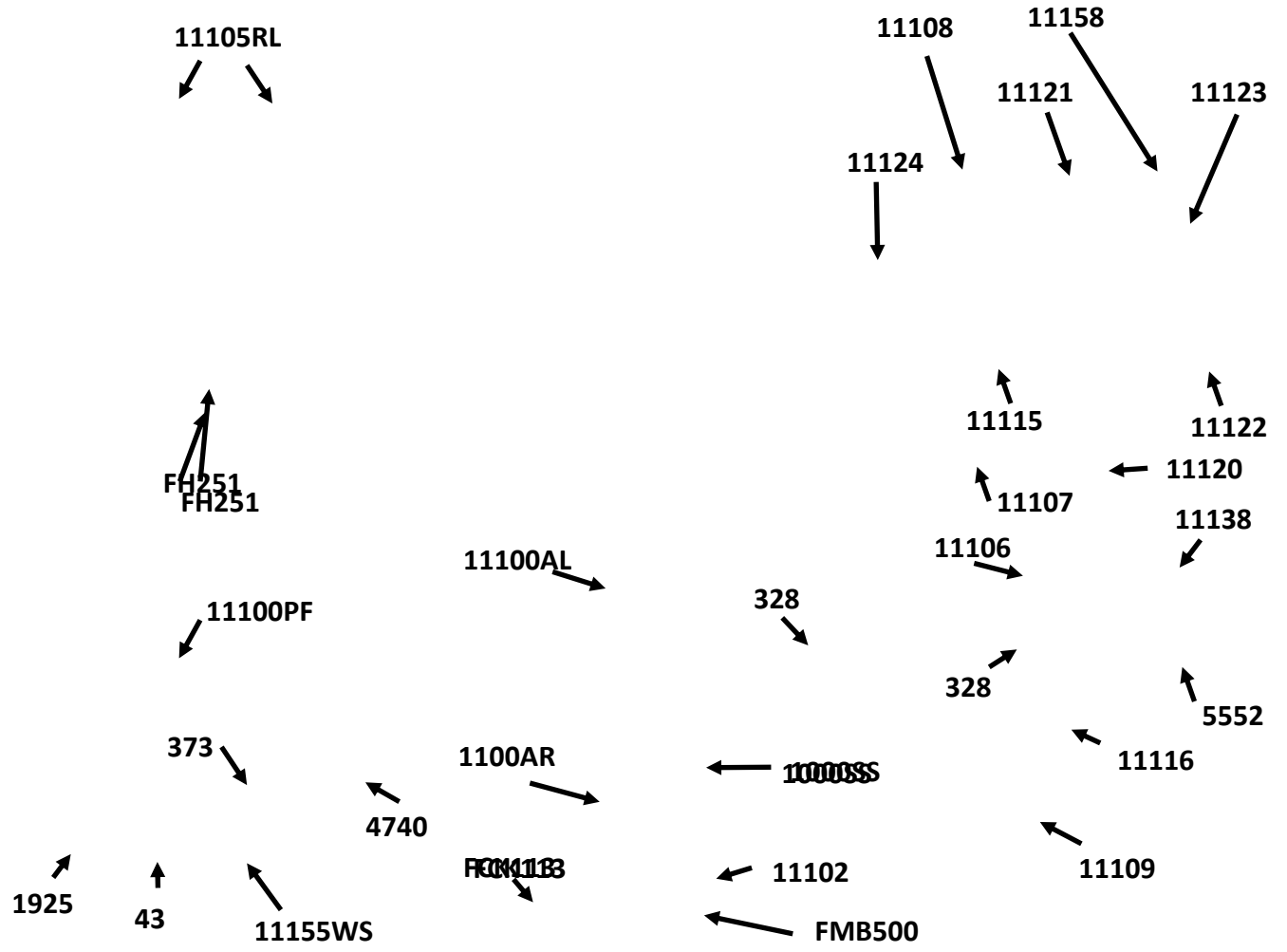

1100—POCKET CHAIN ASSEMBLY

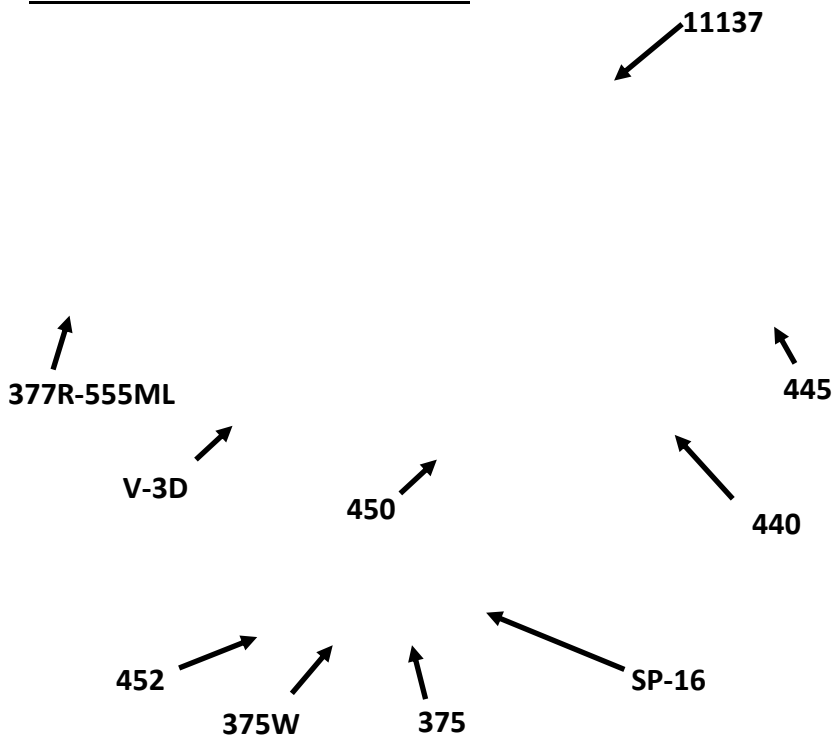

11180—SWEET POTATO SLIP GUIDE



ROUND POINT SHOE PARTS



DOUBLE DISC SHOE PARTS

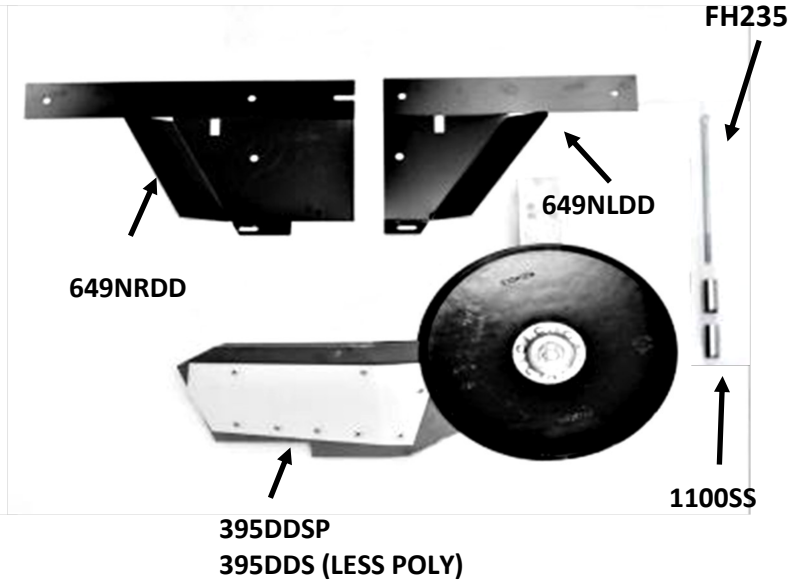

STEEL PACKING WHEEL

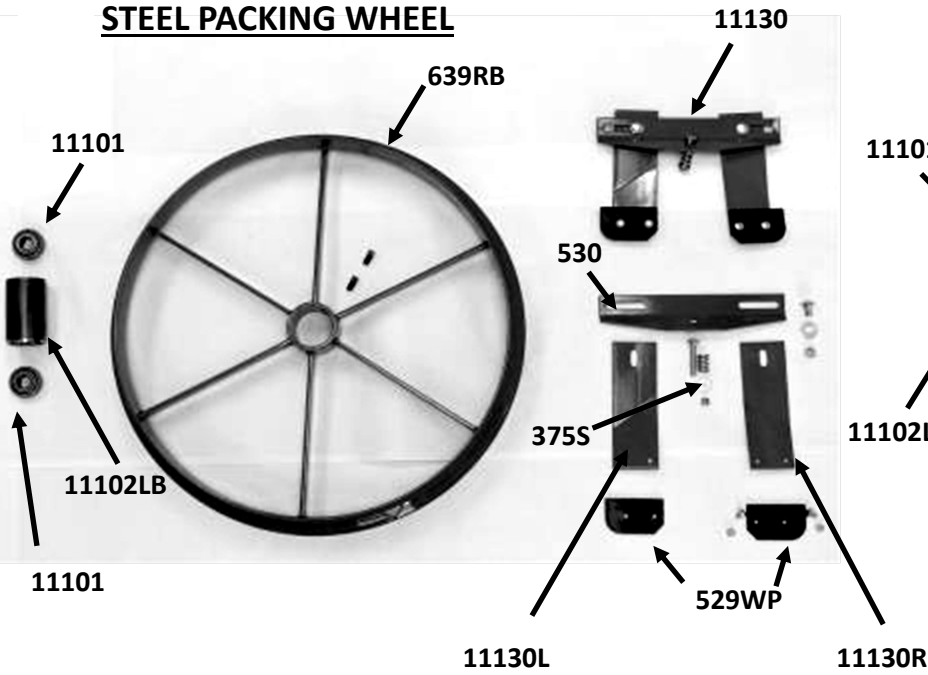

RUBBER PACKER PARTS

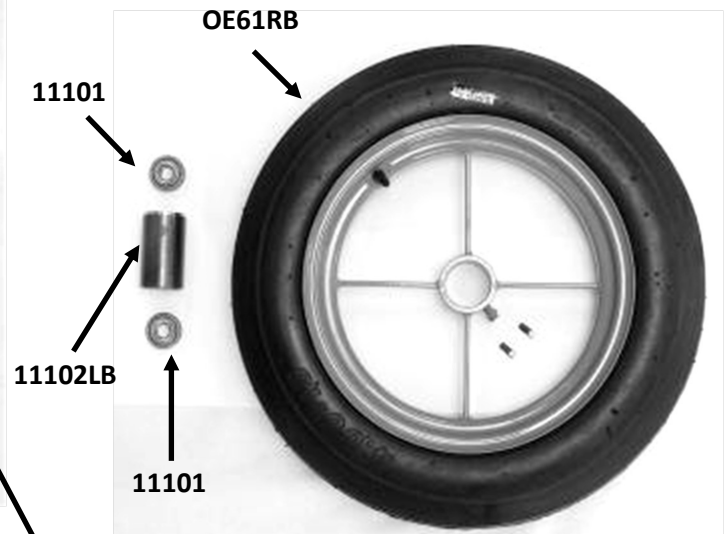

482 CUBE EXTENSION



SP-V3 SPACING BAR SUPPORT

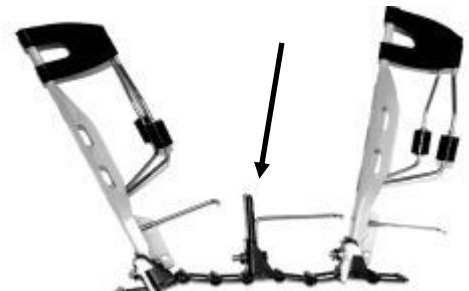

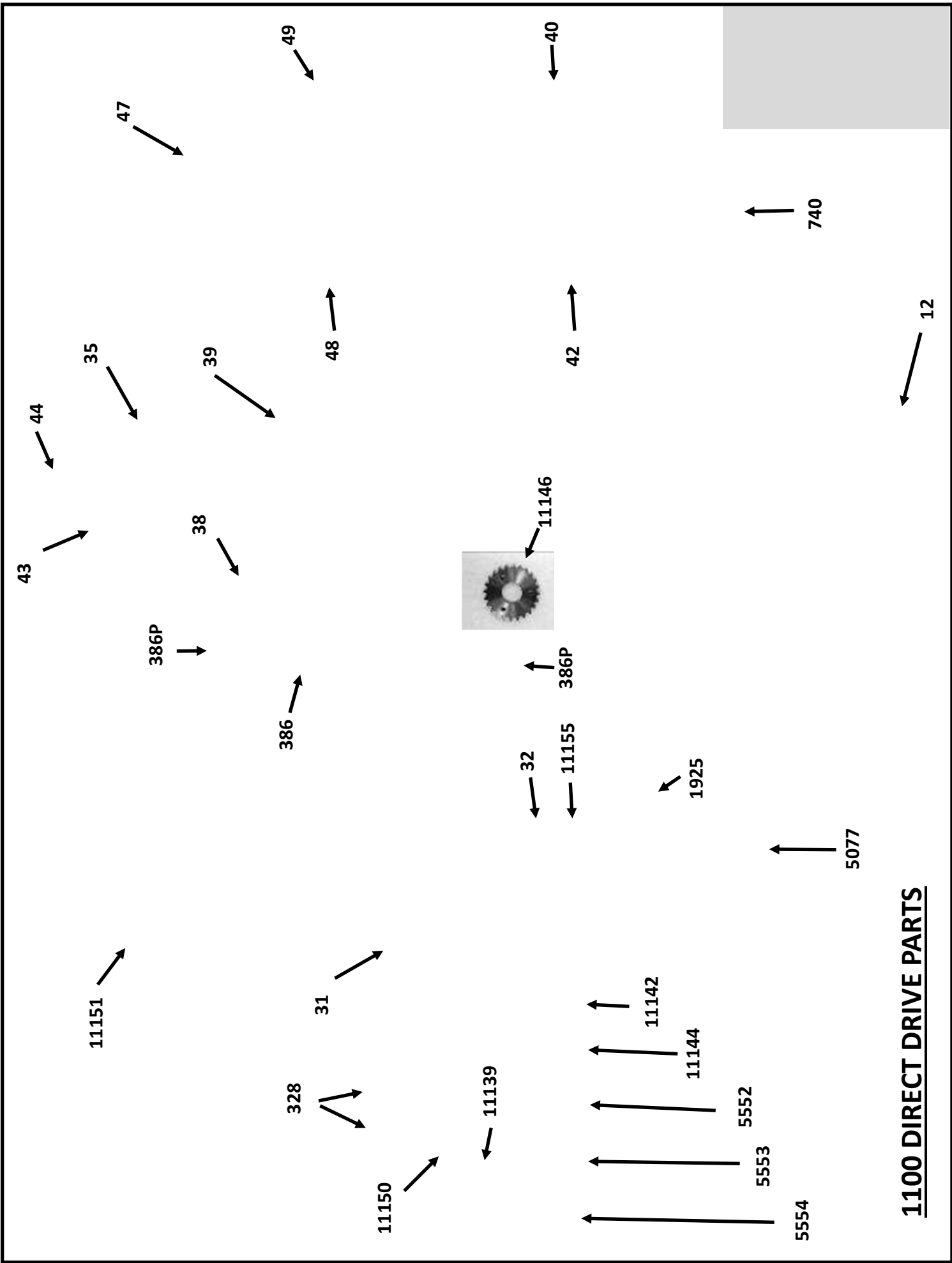

1100 DIRECT DRIVE PARTS

1100 DIRECT DRIVE UNIT - DRIVE PARTS

15
↙

11138 →

11142 →

11144 →

5552 →

5553 →

5554 →

↙ 11153

↙ 11152

↙ 11149

6 LINK - 5563-6

1100LS DRIVE AND HITCH

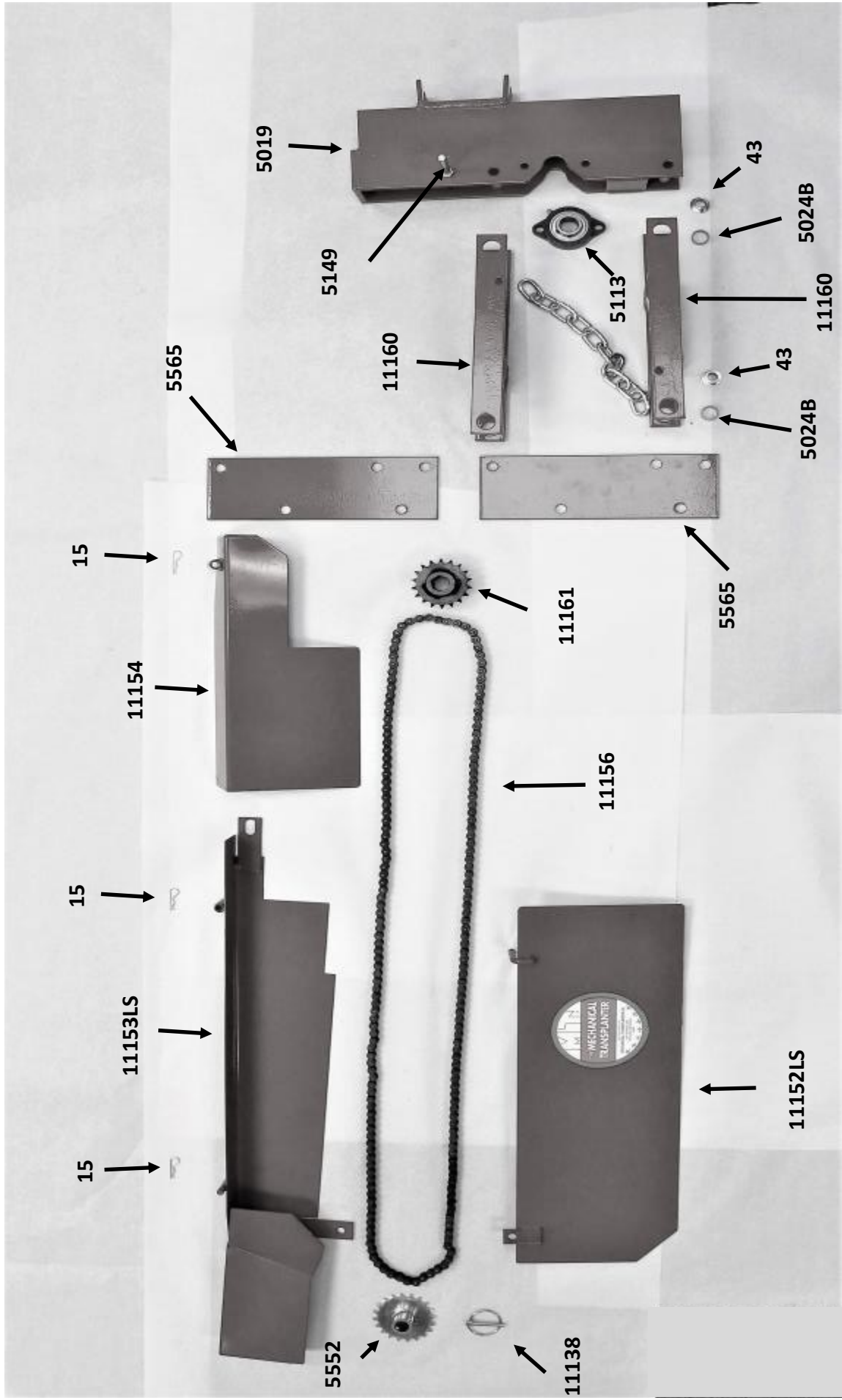

OE 90-1100 / OE90HD Gauge Wheel Drive Parts for 1100LS Units

4731	Bolt with handle for guard	5113	7/8" Hex flange block bearing
5010	Drive wheel hub	5210	Fender less mounting bracket
5011	1-1/4" Flange block bearing	5211	Dummy gage wheel fender bracket
5012	Drive wheel chain	5212	Drive wheel fender mounting bracket
5014	50 Tooth drive sprocket	5213	Fender assembly for dummy guage wheel
5015	Main drive wheel frame	5214	Fender assembly for drive wheel
5016	Rear drive sprocket chain guard	5250	HD main gear box frame
5017	Chain tightener arm	5251	HD drive arch
5021	large drive guard	5252	OE 90HD drive wheel hub
5075	Rubber spacer	5253	HD drive 4 bolt bearing block
5077	Double sprocket cluster chain	5254	HD drive lower shaft
5078	Six sprocket cluster	5255	HD drive 3 cluster sprocket assembly
5079	Six sprocket cluster chain	5256	Ratchet jack for heavy duty drive system.
5080HX	Hex double sprocket chain	5257	HD Drive wheel chain guard
5081HX	Hex triple sprocket cluster	5260	HD drive box small guard
5083	Drive frame	5261	50 tooth drive sprocket - 40A50 1-3/4" Bore
5084HX	Hex lower drive shaft	7472	Crank jack
5085HX	Hex middle drive shaft	7482	5.90 x 15 Traction tire
5086	Upper hex drive shaft	7483	Wheel rim only
5087	Small drive guard	91271	20 tooth x7/8" hex assembly
5088	Chain tightener bracket	FH111	1/4 x 1-1/4 Hex head bolt
5089	2" roller for chain tightener	FH525	3/4 x 4" Hex head bolt
5090	7 Coil chain tightener spring	FH443	5/8 x 3-1/2" Hex head bolt
5092	Chain tightener bracket	FWB399	9/16 x 1-3/4" Wheel stud bolt
5093	5 Coil chain tightener spring		

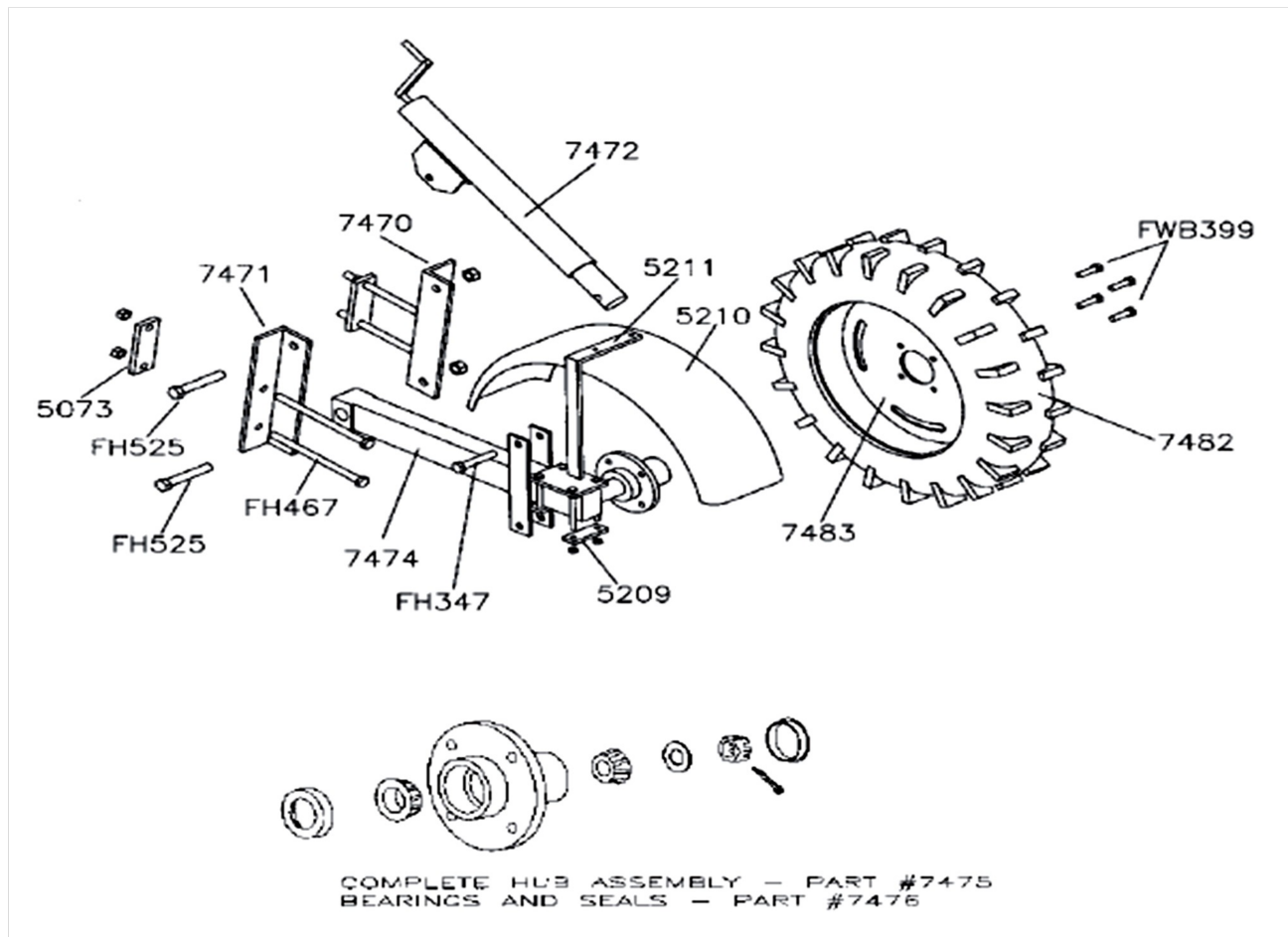

OE90-1100

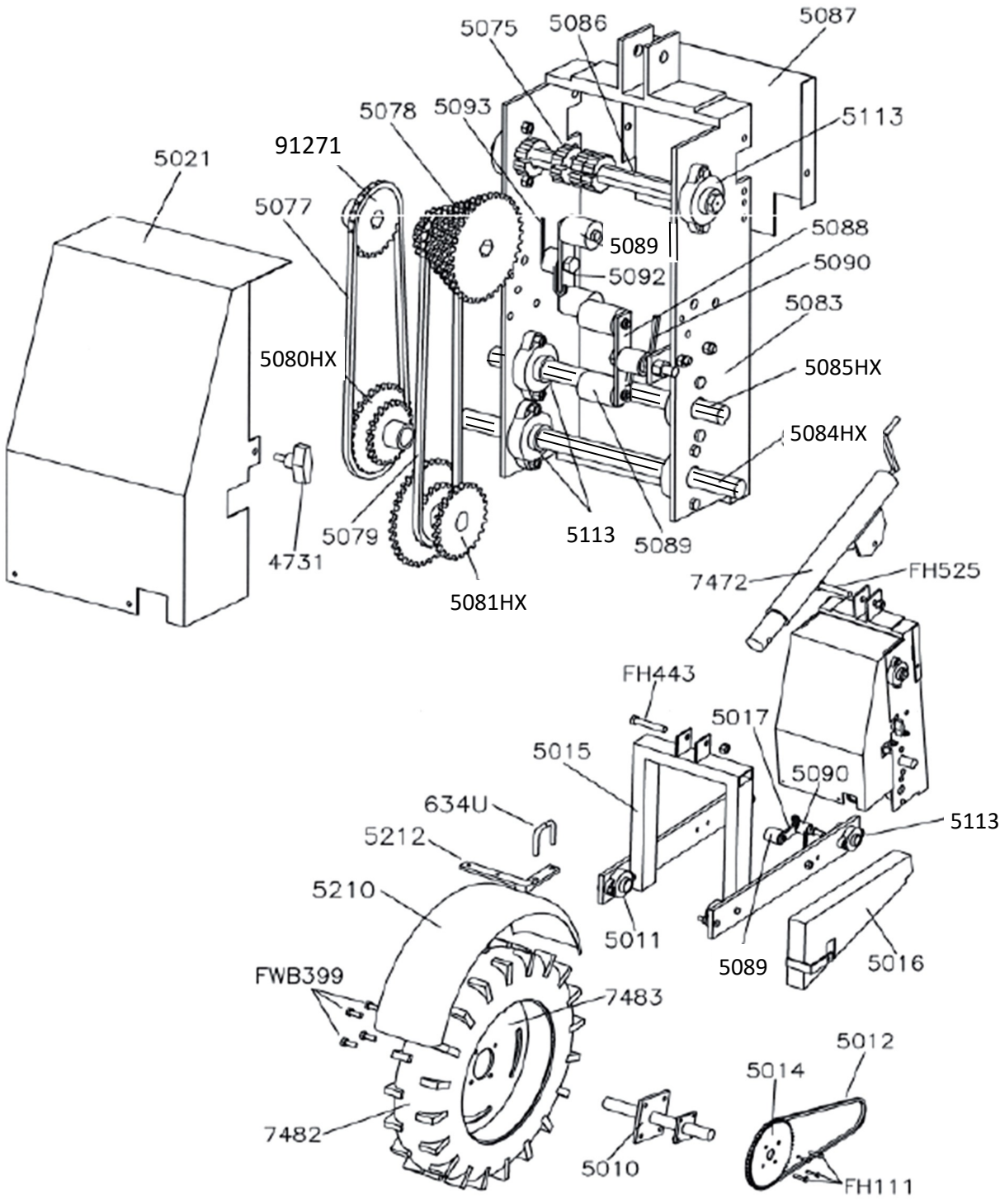

OE90HD

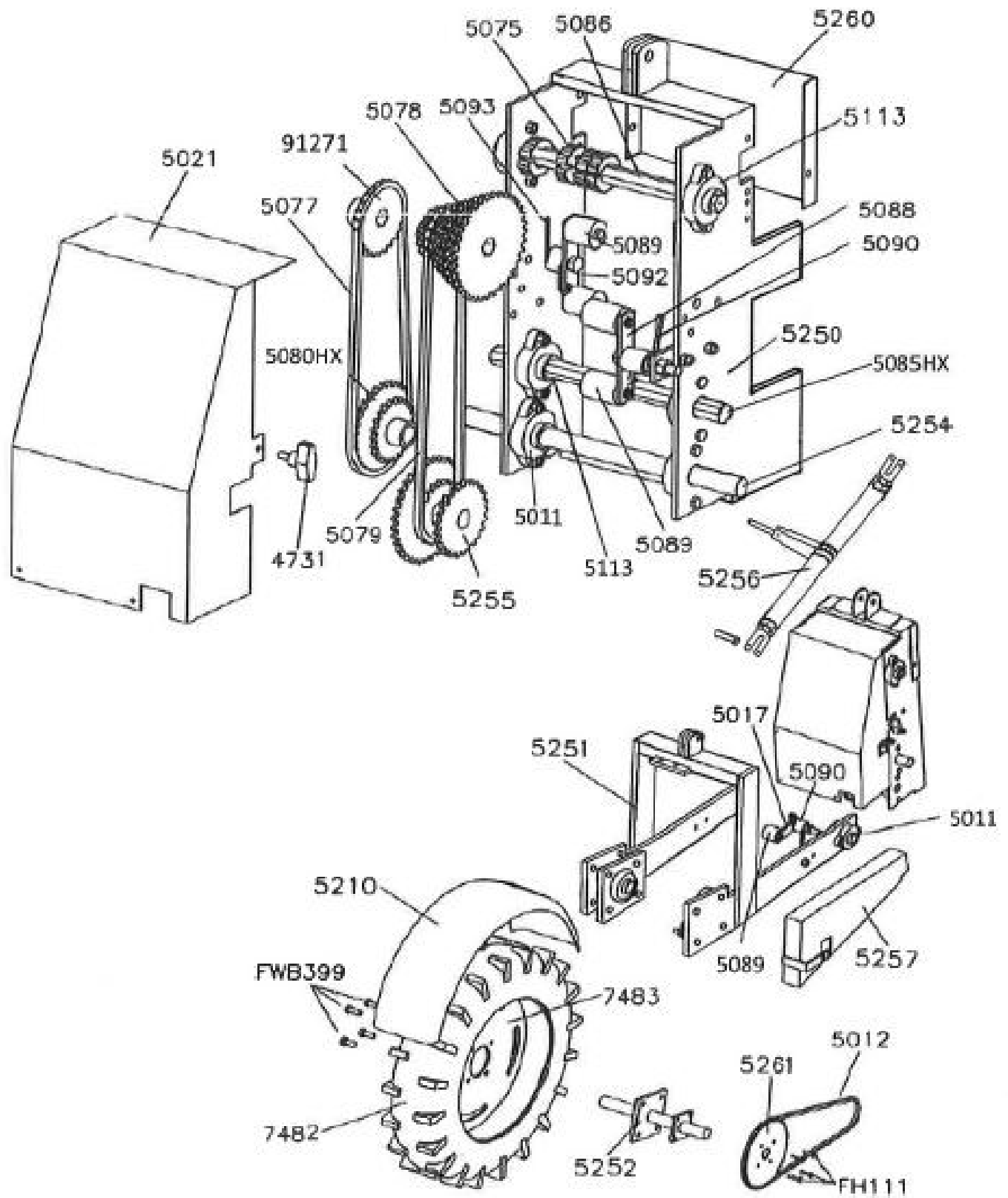

Spacing Chart for 1100LS Units

OE90 Gauge Wheel Drive

16 Pocket Chain

<u>Spacing</u>	<u>Sprocket Arrangement</u>	
7	A3D	
8	A4D	18 Tooth on Drive Shaft
8 ¼	B1D	
9 ½	A5D	20 Tooth on Drive Shaft
10 ½	B2D	
11	A4C	
12	B3D	
12 ½	A5C	
13 ½	B4D	
14 ¼	A6C	
16	B3C	
17 ½	B5D	

Spacing Diagram

To change spacings, refer to sprocket arrangement on chart for desired spacing.
 Slide desired sprocket to 6 sprocket cluster over to align with either sprocket A or B.
 Slide either sprocket C or D to align with sprocket E.
 Use rubber pucks to keep sprockets in place.

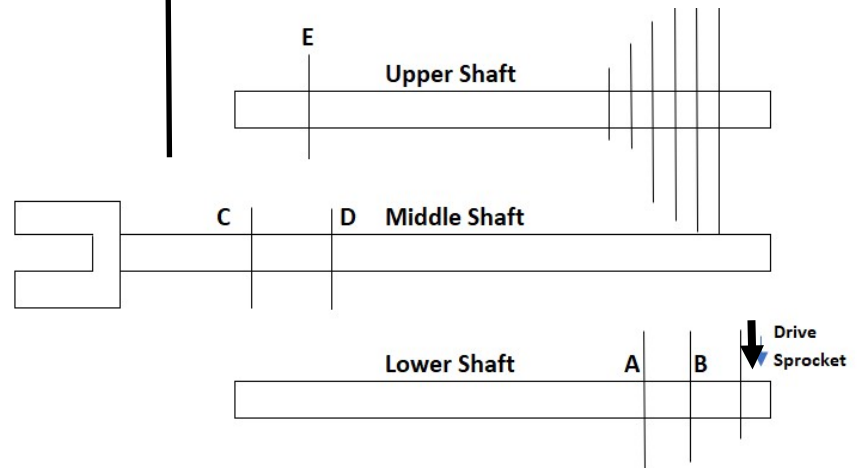

SPACING CHART FOR DIRECT DRIVE 1100 UNIT WITH 16 POCKET CHAIN						
Sprocket on OUTSIDE of Ja ckshaft	Sprocket on INSIDE of Ja ckshaft	Number of Teeth on Sprocket on Unit				
		15	17	20	22	24
15	24			7 1/2 -8" 20.3cm	8 1/2 21.5cm	9" 21.5cm
15	15	8 1/2" 22.8cm	10 1/2" 26.7cm	13" 33cm	15" 38.1cm	17" 40.6cm
17	15	10" 26.7cm	12" 31.7 cm	13" 35.5 cm	15" 38.1 cm	16" 40.6 cm
20	15	12" 30.5 cm	13 " 34.3 cm	15" 38.1 cm	17" 43.2 cm	18 1/2" 47 cm
22	15	13" 33 cm	14" 33.5 cm	18" 39.4 cm	20" 44.5 cm	21" 52 cm
24	15	16" 38.1 cm	17" 45.7 cm	Spacings above 18" use 8 pockets		
Double any of the above spacings by using every other pocket (8 pocket). Make sure HITCH and UNIT are level or parallel to ground when planting.						

Safety Precautions

1. Make sure tractor is stopped and in neutral with the transplanter lowered to the ground before getting on /off the unit.
2. No operator is allowed to be on the unit as it is raised and lowered.
3. No operator is allowed on the transplanter as it is transported to or from the field.
4. All operators must be seated before movement begins and remain seated until the transplanter is completely stopped.
5. Never leave the transplanter in the raised position
6. Keep all shields and guards in place when operating the transplanter.
7. Never attempt repairs or maintenance while the transplanter is in motion.
8. Never put the tractor in reverse while the transplanter is on the ground.
9. Follow all safety instructions supplied by the tractor manufacturer to which the transplanter is mounted.

MACHINE IMPROVEMENTS

MECHANICAL TRANSPLANTER CO. IS ALWAYS STRIVING TO MAKE IMPROVEMENTS ON THEIR LINE OF EQUIPMENT. MECHANICAL TRANSPLANTERCO. RESERVES THE RIGHT TO MAKE IMPORVEMENTS AND CHANGES AT ANY TIME WITHOUT INCURRING OBLIGATIONS TO MAKE SUCH CHANGES OR ADDTIONS TO EQUIPMENT PREVIOUSLY SOLD.

Limited Warranty

Mechanical Transplanter Company, LLC warrants each item of new equipment manufactured by Mechanical to be free from defects in material and workmanship under normal use and service.

The obligation of Mechanical Transplanter Company, LLC under this LIMITED WARRENTY is limited to repairing or replacing as Mechanical may elect, any parts that prove, in Mechanical's judgement, to be defective in material and workmanship within the first season's use of 45 consecutive days after initially placing equipment in operation, whichever occurs first. Any outside work or alterations without Mechanical's written approval will render the LIMITED WARRANTY void.

Mechanical's obligation specifically excludes any liability for consequential damages, such as loss of profits, delays, expenses, damage to goods or property used in connection with or processed in or by the product sold, or damage to the product sold from whatsoever cause, whether or not such loss is due to negligence of selling dealer of Mechanical Transplanter Company, LLC.

This limited warranty shall not apply to any item or machine which shall have been operated in a manner not recommended by the Company nor which shall have been repaired, altered, misused, damaged in an accident, neglected, tampered with or used in any way which in the Company's opinion adversely affects its performance and results.

No person is authorized to give any other warranties or to assume any other liability on behalf of Mechanical Transplanter Company, LLC unless made in writing by Mechanical Transplanter Company, LLC.

This limited warranty covers repair or replacement of Mechanical's equipment only and does not cover crop loss, downtime, labor, damage to other equipment, etc.

This limited warranty does not apply to exterior finishes, tires, chain links, bearings, or any other items sold by Mechanical Transplanter Company, LLC, but warranted by the original manufacturer except to the extent of their individual manufacturer's warranty.

THIS LIMITED WARRANTY IS IN LIEU OF ALL OTHER WARRANTIES, EXPRESSED OR IMPLIED. WARRANTIES OF MERCHANT ABILITY AND FITNESS FOR PARTICULAR PURPOSE ARE EXCLUDED, AS ARE ALL OTHER REPRESENTATIONS TO THE USER-PURCHASER, AND ALL OTHER OBLIGATIONS OR LIABILITIES, INCLUDING LIABILTY FOR INCIDENTAL AND CONSEQUENTIAL DAMAGES, ON THE PART OF MECHANICAL OR THE SELLER.