

Mechanical Transplanter Co.

Model 1000 and 1000B-3

Operators Manual



Mechanical Transplanter Co., LLC
1150 Central Avenue • Holland, MI 49423-5230
Phone: 616-396-8738 • Fax: 616-396-3619
website: www.mechanicaltransplanter.com
e-mail: mtc@mechanicaltransplanter.com

Spacing Charts and Information

| SPACING CHART FOR DIRECT DRIVE UNIT W/ 12 POCKET CHAIN | | | | | | |
|---|---------------------------------|-------------------------------------|-----------------------|-----------------------|-------------------|-----------------|
| Sprocket on OUT-SIDE of Jackshaft | Sprocket on INSIDE of Jackshaft | Number of Teeth on Sprocket on Unit | | | | |
| | | 7 | 8 | 9 | 10 | 11 |
| 7 | 11 | 6" 15.2cm | 6-1/2" - 7" 17.8cm | 7-1/2" - 8" 20.3cm | 8-1/2" 21.6cm | 9" 22.8cm |
| 7 | 7 | 9" 22.8cm | 10-1/2" 26.7cm | 13" 33cm | 15" 38.1cm | 16" 40.6cm |
| 8 | 7 | 10-1/2" 26.7cm | 12-1/2" 31.7cm | 14" 35.5cm | 15" 38.1cm | 16" 40.6cm |
| 9 | 7 | 12" 30.5cm | 13-1/2" 34.3cm | 15" 38.1cm | 17" 43.2cm | 18-1/2" 47cm |
| 10 | 7 | 13" 33cm | 14" 35.5cm | 15-1/2" 39.4cm | 17-1/2" 44.5cm | 20-1/2" 52cm |
| 11 | 7 | 15" 38.1cm | 18" 45.7cm | | | |

Double any of the above spacings by using every other pocket (6 pocket).
Make sure HITCH and UNIT are level or parallel to the ground when planting.

Use for Model 1000

| DISC SPACING CHART FOR MODELS W/ DIRECT DRIVE | | | | | | | |
|--|---------------------------------|-------------------------------|-------------------------------------|--------|--------|--------|--------|
| Sprocket on OUTSIDE of Jackshaft | Sprocket on INSIDE of Jackshaft | Number of Pockets on the Disc | Number of Teeth on Sprocket by Disc | | | | |
| | | | 7 | 8 | 9 | 10 | 11 |
| 7 | 7 | 24 | | 2" | 2-1/4" | 2-1/2" | 2-3/4" |
| | | 16 | 3" | 3-1/4" | 3-1/2" | 4" | 4-1/2" |
| | | 12 | | 4-3/4" | 5-1/4" | 5-3/4" | 6-1/4" |
| 8 | 7 | 24 | | 2-1/2" | 3" | 3-1/4" | 3-1/2" |
| | | 16 | 3-1/2" | 3-3/4" | 4-1/4" | 4-1/2" | 5-1/4" |
| | | 12 | | 6" | 6-1/4" | 6-3/4" | 7" |
| 9 | 7 | 24 | 2-1/2" | 2-3/4" | 3-1/4" | 3-1/2" | 4" |
| | | 16 | 3-3/4" | 4-1/4" | 4-1/2" | 5" | 5-1/2" |
| | | 12 | 4-1/2" | 6-1/4" | 6-1/2" | 7-1/4" | 8" |
| 10 | 7 | 24 | 2-1/2" | 3" | 3-1/2" | 3-3/4" | 4-1/2" |
| | | 16 | 3-3/4" | 4-1/2" | 5-1/4" | | |
| | | 12 | 5-1/4" | 6" | 7" | 7-1/2" | 8-1/2" |
| 11 | 7 | 24 | 2-1/2" | 3" | 3-1/2" | 4-1/4" | 4-3/4" |
| | | 16 | 4" | 5" | 6" | | |
| | | 12 | 5-1/2" | 6-1/2" | 7-1/2" | 9" | 10" |

Use for Model 1000 with disc mounted pockets

Assembly Instructions

For Model 1000 Series Transplanters

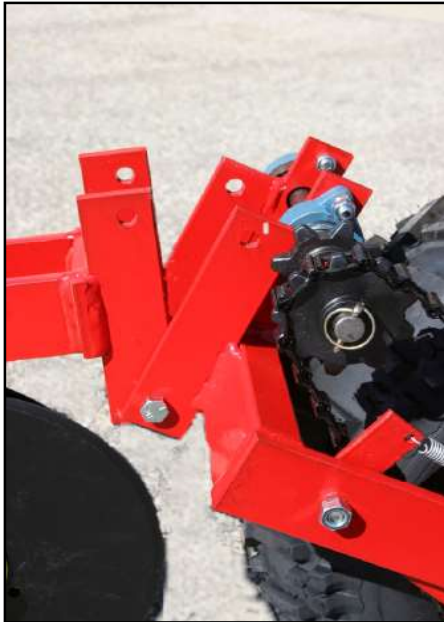

1. Bolt on the Direct Drive Float Wheel using the four 1/2 x 1-1/2 " bolts. Secure using the 1/2" hex nuts.



2. Remove the following parts from the direct drive wheel jackshaft: Clip pin, drive chain coming from the wheel, outside sprocket on jackshaft, and pipe spacer. Then remove the extra top hex nut located on the flange bearing.



3. Install the inside chain guard of the unit. Fasten front short tab to the top bolt on flange bearing from #2 photo with hex nut. The long tab attaches to the empty hole on the transplanter frame by the packing wheels. The guard must fit between the shoe brace and the guide adjustment bolt. Use the 3/8 x 1" bolt and a 3/8" hex nut to secure.

4. Select the proper sprocket arrangement for the spacing needed between plants. Look on page 2 or the chart on the side of your transplanter for the correct arrangement. For spacings using 11 tooth sprockets, extra chain links may be needed to lengthen the drive chain. These links are wired to the lift chain by the drive wheel. After finding the correct sprockets, run the long drive chain from the sprocket on the pocket chain shaft to the inside sprocket on the jackshaft of the direct drive wheel. The chain must go over the idler sprocket on the shoe brace and under the chain tightener sprocket as shown in the photo below.



5. Slide the red pipe spacer back onto the jackshaft. Insert the roll pin back into the second hole from the outside of the jackshaft. Slide the outside sprocket over the roll pin. Slide the drive chain coming from the drive wheel over the outside jackshaft sprocket. You may have to use your hand to push the chain tightener up to create enough slack in the chain. Insert the clip pin into the outside hole of the jackshaft.



6. Slide the outside chain guard onto the two pins and secure with clip pins.

Installation of Plant Stands

It is very important to know what row width will be used before installing the plant stands on multi-row transplanter. Follow the chart below.

- 42" Row Spacing - All Wide Plant Boxes
- 41" to 36" Row Spacing - Narrow Plant Boxes Inside
- 35" to 24" Row Spacing - One Wide Inside & Two Wide Outside
- 23" to 21" Row Spacing - One Narrow Inside & Two Wide Outside
- Less than 21" Row Spacing - Wide Outside Plant Boxes Only



1. Remove the long bolt between the uprights by the pocket chain. Do not lose the spacer between the uprights. Remove the outside cotter key in each axle.



2. Install the slotted mounting plates on both sides of the planter using the long bolt just removed. Do not tighten until the plant stand is fully assembled.



3. Slide plant stand onto the packing wheel axle and insert cotter key. Bend cotter key ends to keep in place.

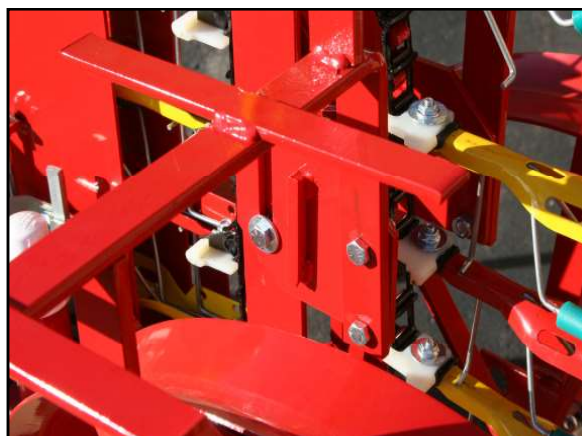

4. Use two 3/8 x 1" hex head bolts and two 3/8" nuts to attach plant stand frame to the slotted mounting bracket.



5. Attach the width adjustment plate with either the inside or outside hole depending on if you are using the wide (standard) plant boxes or the narrow with 3/8 x 1" hex head bolt and nut.

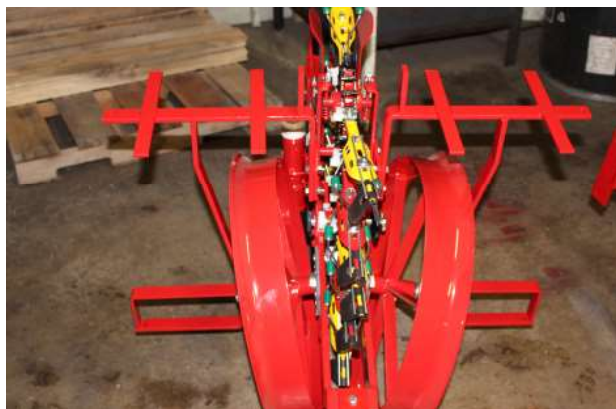

6. Install the plant boxes. These can be adjusted forward or backward for operator comfort.



Assembling the L-Shaped Seat Braces



1. Assemble the L-shaped seat brace by the chain guard. The sea brace mounts on the inside of the frame. The U-bolt mounts from the outside of the transplanter frame under the chain guard. Secure with 1/2" washers and 1/2" hex nuts over each threaded end.



2. The second L-shaped seat brace gets attached on the outside of the transplanter opposite the chain guard. The seat brace mounts on the outside of the frame with the U-bolt coming from the inside of the frame going outside through the seat brace. Secure with 1/2" washers and 1/2" hex nuts over each threaded end.

Mounting your Fiberglass or Cushion Seat

•Fiberglass Seats•



Fiberglass Seat - Turn your fiberglass seat over and remove any covers over the threaded studs. Take your green fiberglass seat bracket and mount it to the bottom of the seat with the side with the bend towards the front of the seat. Secure with four 1/4" hex nuts. Insert the 1/2 x 1-1/2 carriage bolt through the brace and then through the L-shaped seat bracket. Secure with a 1/2" washer and hex nut.

•Cushion Seats•

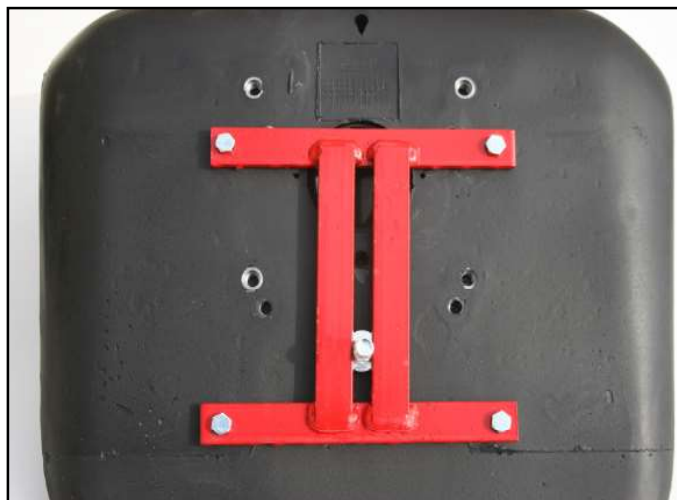

Cushion Seat - Slide the 1/2" x 1-1/2" carriage bolt through the bottom of the red seat bracket before mounting the seat bracket to the seat. After placing the carriage bolt through the seat bracket, place the seat bracket on the cushion seat. Secure with four 5/16" x 1" hex head bolts. Place the seat on the L-shaped seat bracket and secure with a 1/2" washer and hex nut.

Loose Pocket Assembly

If your Model 1000 was shipped in a crate, a pocket must be put on the empty attachment link.

The empty attachment link should be right at the top of the chain when the unit is shipped. If it is not, turn the drive wheel until the empty attachment link comes to the top.



Do NOT put #445 rubber gripper onto spring wires(#440) until pocket is assembled to attachment link.

Take the extra V-3 pocket that is wired onto unit and loosen the pocket bolt. Put pocket bolt through the attachment link. Make sure spacing bar stays under the head of the bolt. Place #375 water trip on the back of attachment link, then the 1/4" fender washer. Secure with 1/4" flange nut. After the bolt has been tightened, slide the top part of the #445 rubber gripper to the #440 wire.

Instructions for Direct Drive Clamps

The following instructions are for mounting the direct drive clamps to your Model 1000 unit. Although the pictures show the 2-1/2" clamps, use these instructions for any clamp style. They all mount the same way.



1. Insert a metal bushing from the inside of the frame. Put one of the 1/2 x 1-1/2" bolts through the bushing also from the inside.



2. Attach the clamp to the bolt in the **top** hole of the bottom set of large holes. Secure with a 1/2" hex nut.
3. If you have a Model 1000B-3 or 1000-2 follow directions below for one clamp side only. To mount safety bar on other clamp side, see page 11. In the **top** set of holes, place a 7/16 x 1-1/4" bolt through the top hole.

4. Slide the end link of the chain onto the bolt.
5. Secure the chain with a 3/8" washer and then a 7/16" hex nut. Make sure the nut is very tight.





6. Use the same instructions for the other side of the Direct Drive Wheel.

Note: The clamps may be reversed or fastened on the inside of the frame for narrow row spacings. Also, if other clamps are in the way, two lefts or two rights may be used. The lower holes on the clamps are for higher toolbars on older models or on tractors where 3-point hitch will not go low enough. Correct height of toolbar is 14" to center.

The Model 1000 unit can now be mounted to your 3-point hitch or toolbar. Following is a list of fasteners that you must use for various toolbars.

Toolbar Hardware List

- 2-1/2" or 2-1/4" Diamond toolbar - 7/8" V-bend U-bolt (2)
- 3" x 3" Flat Toolbar - 3/4" x 5" Hex bolts (4)
- 4" x 4" Flat Toolbar - 3/4" x 6" Hex bolts (4)
- 4" x 7" Toolbar - 3/4" x 9-1/2" Hex bolts (4)
- 5" x 7" Toolbar - 3/4" x 7" Hex bolts (4)
- 7" x 7" Toolbar - 3/4" x 9-1/2" (4)



Shown with clamps reversed

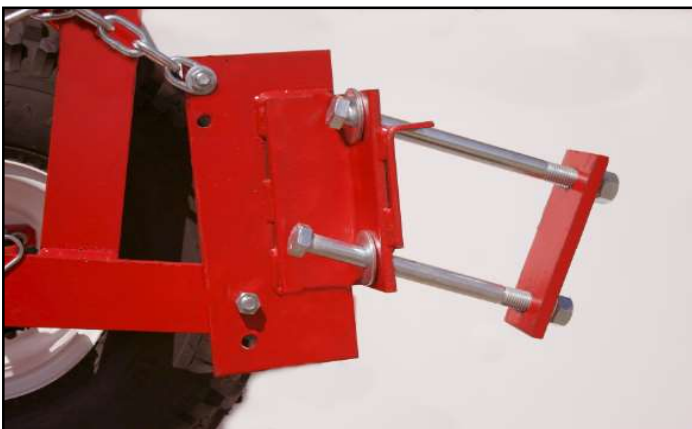

4 x 7 Toolbar Clamp. Use 2-3/4 x 9-1/2" hex bolts, 2-3/4" hex nuts and 2-3/4" washers.

Note: bent bracket on front of clamp

Model 1000B-3 Barrel Mounting & 3-Point Hitch Instructions



For B-3 Model, make sure the safety bar is properly installed!

To mount this safety bar, you must remove the 7/16 x 1-1/4" bolt from on side of the direct drive wheel.

1. Locate the special 2-1/2" stud in your bag of bolts and nuts.
2. Turn a 7/16" hex nut all the way onto the stud.
3. Put the 7/16" washer on the stud next to the nut.
4. Place the lift chain up against the washer.
5. Slide the stud through the hole on the Direct Drive frame and secure with a 7/16" hex nut.
6. Assemble another stud the same way and fasten it to the top hole of the front Direct Drive clamp.
7. Attach the red seat safety bar to the stud on your drive wheel. **The end with the hole must go on the clamp. The slotted end must go on the frame.** After the safety bar is attached, place the small clip pins through the small holes.

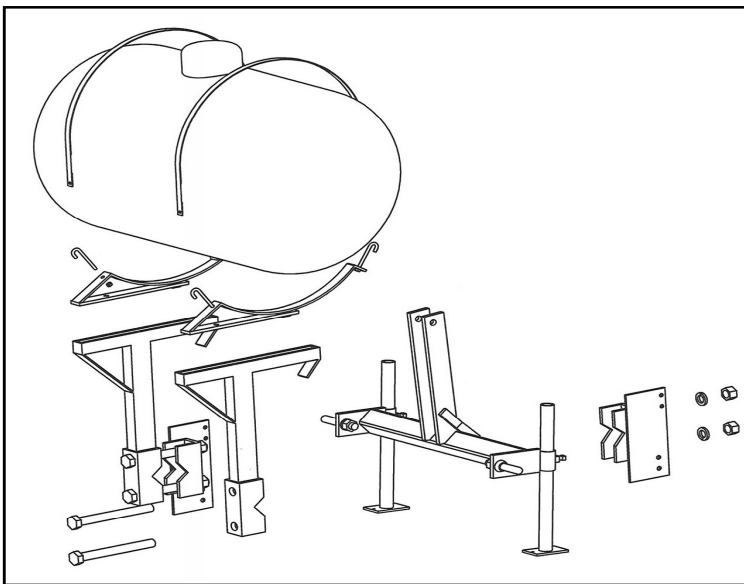

3-Point Hitch & Barrel Mounting

1. On the 3-point hitch, connect the Category I hitch pins through the holes on the outside of the hitch. Put the pins in through the outside and secure with the lock washer and hex nut included with the pin.
2. Slide the green pipe stands up through the pipes on the hitch, then tighten by turning the set screw.

Note: The following instructions will be easier with two people



3. Center the 3-point hitch toolbar with the clamps on your transplanter. Next, line up one of the barrel mounting brackets with the direct drive clamps. Secure using two 1 x 8-1/2 bolts and hex nuts. Do the same with the other barrel mounting bracket.



Side view of B-3 mountings



4. Bolt barrel hoops onto B-3 supports using 1/2 x 3" hex bolt with 1/2" lock nut. Note below: the hoops can be mounted in a forward or back position, depending on clearance that you need for the tractor fenders etc.



5. Screw in the nipple into the bottom of the tank.



6. Insert J-bolts into the four holes on the barrel hoops. It works best to thread 5/16" nut onto J-bolt before hooking up barrel hoops.



7. The 55 gallon poly tank can now be mounted on top of the barrel mountings. Use the four J-bolts and the galvanized straps to secure the barrel to the mountings.

A. Grease all fittings before the start of each day. Grease fittings are found:

1. On each packing wheel axle.
2. Upper pocket chain sprocket (Model 1000 only)
3. Direct drive tire hub (Direct Drive Units only)
4. On each nylon bushing on the pocket chain jackshaft.

B. Regulating Plant Depth

1. All operators should take care to see that the plants are placed well down in the pocket so the plant is held firmly.
2. The plant depth is regulated by the distance the root is extended out of the pocket.
3. To set the plants deeper, simply set the plant in the pocket with the roots further out than what is normally done. (See figure below)
4. If planting strawberries the axle must be raised up, allowing the transplanter unit to go deeper into the soil to cover the strawberry crowns.



V-3 Standard Plant Placement



Deeper Plant Placement

C. Pocket Chain Instructions

1. Make sure that bolts holding the upper sprocket on the pocket chain are not too tight. This will cause unnecessary friction on the unit and possible slippage on packing wheel drive transplanter. Simply loosen the wing nuts if the chain seems too tight.
2. Tighten the wing nuts equally by the top sprocket to keep the chain running level at all times.
3. If in row spacings of 20" or greater are needed, use only 6 pockets. You may remove every other pocket or leave them on. This gives the same speed or greater as a 12 pocket chain.

D. Adjusting or setting the #395R Round Point Shoe

Note: The shoe is preset at the factory for almost all situations.

Follow these instructions only if plants are leaning or in extreme wet or dry soil conditions.

1. Whenever any adjustments are made, be sure to get the shoe directly square and straight in front of the opening of the packing wheels. Make sure that the pockets will run through the middle of the shoe.
2. In loose dry soil, the shoe should be adjusted closer to the packing wheels. This can be done by adjusting the diagonal brace on the shoe.
3. In wet heavy soil, the shoe should be adjusted away from the packing wheels. Again, this can be done by adjusting the diagonal shoe brace.
4. Keep the shoe clean at all times. Do not allow dirt or trash to build up on the front or side of the shoe because this can cause too wide of a furrow that cannot be closed properly by the packing wheels. Poly covered shoes will eliminate this problem.

E. Water Valve Adjustment

1. For more water, make sure the valve is getting a full stroke by adjusting the #604 bracket on the pump rod. Make sure the valve does not over stroke. You should be able to lift the 604 rod 1/4-1/2" at the top of its stroke.
2. A broad range of adjustment can be achieved with the #603 water cam.
3. For wider spacings, the water cam may have to be raised so the water is on the plant. If the #603 is raised, be sure to raise the #604 water adjustment bracket accordingly and do not over stroke.

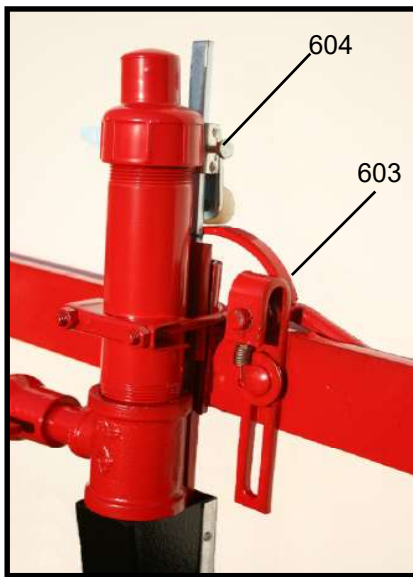

Example: At 20" row spacing, the #603 water cam should be adjusted nearly all the way up the slot. The #604 water adjustment must also be adjusted accordingly so a 1/2" remains on the 604 stroke.

4. Tilting the #603 water cam back towards the water trips on the pockets will create a longer stroke of water or more water before and after the plant.
5. Always empty the water out of the valve after quitting for the day. **Water freezing inside the valve will destroy the #610 and #612 balls inside the valve.**

F. Direct Drive Float Wheel Operation

1. Use only 4 to 5 pounds of air pressure in the Direct Drive Wheel during operation.



Wrong
Toolbar too high



Correct



Wrong
Toolbar too low

2. It is very important when starting to transplant, that the lift chains on the side of the Direct Drive Wheel are loose. See above "Correct" picture.
3. When lowering the transplanting unit into the ground, be sure that the frame members on the Direct Drive Wheel run parallel as is shown in the center picture. This is adjusted by the height of the hitch or toolbar (a pair of gauge wheels will eliminate adjustment of toolbar height).
4. Running the frame parallel will keep the lift chains loose allowing for proper floatation in the Direct Drive Wheel.
5. Running the frame members parallel and level will allow the packing wheels to run in the proper packing position.
6. Running the toolbar too low will tighten the back chains and cause the packing wheels to run too light and not pack the soil properly.
7. Running the toolbar too high will tighten the front lift chains and cause the Direct Drive Wheel to not run on the ground, especially through low spots.

Trouble Shooting

Important - Before attempting any of the following, make sure that the unit is running level or parallel to the ground. Do not run the front hitch or toolbar too far down or up. On all Model 1000 series units, make sure that the chains are loose on both sides of the arch bracket over the drive wheel. For all transplanter, make sure the soil is worked deep enough.

Problem

Solution

Packing wheels not packing properly

- A. Lengthen third arm on tractor to get float in hitch
- B. Hitch is too far down and needs to be lifted (lift chains are not loose)
- C. Clean off sides of shoe
- D. Work soil deeper
- E. Add weight to back of unit
- F. Poly shoes will eliminate soil building up on the outsides

Water leaks from top of water valve

- A. Check to see if the rubber nipple inside the top of the valve is in place and rounded.
- B. #610 ball inside the valve has collapsed and needs to be replaced.

Water leaks from bottom of water valve

- A. Rubber ball #612 on pin is broke and needs to be replaced
- B. The nylon nut on the bottom is broken and needs to be replaced

Water not uniform

- A. Make sure all the water trips on the pockets are in good shape and at even distances from the attachment link.
- B. Check to see that all springs on the water valve are in good working order.
- C. Water valve has dirt or residue build up that needs to be cleaned out

Water misses plants

•See water valve instructions on Page13.

Plants falling out of pocket

- A. Inspect the rubber grippers to make sure that they are not all stretched out.
- B. Tighten the L-bolts on the side of the guides.
- C. #482 pocket extensions may be needed if planting cell-type plants.
- D. Check bottom of guides to insure that the pocket is not releasing the plant too soon.

Plants on top of soil

- A. Cut back on water because the plants are floating up out of the shoe.
- B. Plants need to be pulled further out of the pocket to put them deeper.
- C. Too much loose soil is getting inside the shoe before the packing wheels can pack. Move shoe closer to packing wheels.
- D. A gap might be occurring by having the hitch too low causing the packing wheels to be up in the air or not being able to put enough pressure on the soil.
- E. Ground not worked deep enough causing the shoe to not go deep enough into the soil.

Plants leaning

- A. Need to put plant further in the pocket to keep it from hitting the bottom of the furrow.
- B. Possibility of needing a deeper shoe.
- C. May need #482 extensions to help support the cell of a plant coming from a tray.
- D. See Operating Instructions on Page 13 about adjusting the shoe.

Safety Precautions

1. Make sure tractor is stopped and in neutral with the transplanter lowered to the ground before getting on and off the unit.
2. No operator is allowed to be on the unit as it is raised and lowered.
3. No operator is allowed on the transplanter as it is transported to or from the field.
4. All operators must be seated before movement begins and remain seated until the transplanter is completely stopped.
5. Never leave the transplanter in the raised position.
6. Keep all shields and guards in place when operating the transplanter.
7. Never attempt repairs or maintenance while the transplanter is in motion.
8. Never put the tractor in reverse while the transplanter is on the ground.
9. Follow all safety instructions supplied by the tractor manufacturer to which the transplanter is mounted.

MACHINE IMPROVEMENTS

MECHANICAL TRANSPLANTER CO. IS ALWAYS STRIVING TO MAKE IMPROVEMENTS ON THEIR LINE OF EQUIPMENT. MECHANICAL TRANSPLANTER CO. RESERVES THE RIGHT TO MAKE IMPROVEMENTS AND CHANGES AT ANY TIME WITHOUT INCURRING OBLIGATIONS TO MAKE SUCH CHANGES OR ADDITIONS TO EQUIPMENT PREVIOUSLY SOLD.

Limited Warranty

Mechanical Transplanter Company warrants each item of new equipment manufactured by Mechanical to be free from defects in material and workmanship under normal use and service.

The obligation of Mechanical Transplanter Company under this LIMITED WARRANTY is limited to repairing or replacing as Mechanical may elect, and any parts that prove, in Mechanical's judgment, to be defective in material and workmanship within the first season's use or 45 consecutive days after initially placing equipment in operation, whichever occurs first. Any outside work or alterations without Mechanical's written approval will render the LIMITED WARRANTY void.

Mechanical's obligation specifically excludes any liability for consequential damages, such as loss of profits, delays, expenses, damage to goods or property used in connection with or processed in or by the product sold, or damage to the product sold from whatsoever cause, whether or not such loss is due to negligence of selling dealer of Mechanical Transplanter Company.

This limited warranty shall not apply to any item or machine which shall have been operated in a manner not recommended by the Company nor which shall have been repaired, altered, misused, damaged in an accident, neglected, tampered with or used in any way which in the Company's opinion adversely affects its performance and results.

No person is authorized to give any other warranties or to assume any other liability on behalf of Mechanical Transplanter Company, unless made in writing by Mechanical.

This limited warranty covers repair or replacement of Mechanical Transplanter Co. equipment only and does not cover crop loss, downtime, labor, damage to other equipment, etc.

This limited warranty does not apply to exterior finishes, tires, chain links, bearings, or any other items sold by Mechanical Transplanter Co., but warranted by the original manufacturer except to the extent of their individual manufacturer's warranty.

THIS LIMITED WARRANTY IS IN LIEU OF ALL OTHER WARRANTIES, EXPRESSED OR IMPLIED. WARRANTIES OF MERCHANTABILITY AND FITNESS FOR PARTICULAR PURPOSE ARE EXCLUDED, AS ARE ALL OTHER REPRESENTATIONS TO THE USER-PURCHASER, AND ALL OTHER OBLIGATIONS OR LIABILITIES, INCLUDING LIABILITY FOR INCIDENTAL AND CONSEQUENTIAL DAMAGES, ON THE PART OF MECHANICAL OR THE SELLER.

Mechanical Transplanter Co.

Model 1000 and 1000B-3

Operators Manual



Mechanical Transplanter Co., LLC
1150 Central Avenue • Holland, MI 49423-5230
Phone: 616-396-8738 • Fax: 616-396-3619
website: www.mechanicaltransplanter.com
e-mail: mtc@mechanicaltransplanter.com

Spacing Charts and Information

| SPACING CHART FOR DIRECT DRIVE UNIT W/ 12 POCKET CHAIN | | | | | | |
|---|---------------------------------|-------------------------------------|-----------------------|-----------------------|-------------------|-----------------|
| Sprocket on OUT-SIDE of Jackshaft | Sprocket on INSIDE of Jackshaft | Number of Teeth on Sprocket on Unit | | | | |
| | | 7 | 8 | 9 | 10 | 11 |
| 7 | 11 | 6" 15.2cm | 6-1/2" - 7" 17.8cm | 7-1/2" - 8" 20.3cm | 8-1/2" 21.6cm | 9" 22.8cm |
| 7 | 7 | 9" 22.8cm | 10-1/2" 26.7cm | 13" 33cm | 15" 38.1cm | 16" 40.6cm |
| 8 | 7 | 10-1/2" 26.7cm | 12-1/2" 31.7cm | 14" 35.5cm | 15" 38.1cm | 16" 40.6cm |
| 9 | 7 | 12" 30.5cm | 13-1/2" 34.3cm | 15" 38.1cm | 17" 43.2cm | 18-1/2" 47cm |
| 10 | 7 | 13" 33cm | 14" 35.5cm | 15-1/2" 39.4cm | 17-1/2" 44.5cm | 20-1/2" 52cm |
| 11 | 7 | 15" 38.1cm | 18" 45.7cm | | | |

Double any of the above spacings by using every other pocket (6 pocket).
Make sure HITCH and UNIT are level or parallel to the ground when planting.

Use for Model 1000

| DISC SPACING CHART FOR MODELS W/ DIRECT DRIVE | | | | | | | |
|--|---------------------------------|-------------------------------|-------------------------------------|--------|--------|--------|--------|
| Sprocket on OUTSIDE of Jackshaft | Sprocket on INSIDE of Jackshaft | Number of Pockets on the Disc | Number of Teeth on Sprocket by Disc | | | | |
| | | | 7 | 8 | 9 | 10 | 11 |
| 7 | 7 | 24 | | 2" | 2-1/4" | 2-1/2" | 2-3/4" |
| | | 16 | 3" | 3-1/4" | 3-1/2" | 4" | 4-1/2" |
| | | 12 | | 4-3/4" | 5-1/4" | 5-3/4" | 6-1/4" |
| 8 | 7 | 24 | | 2-1/2" | 3" | 3-1/4" | 3-1/2" |
| | | 16 | 3-1/2" | 3-3/4" | 4-1/4" | 4-1/2" | 5-1/4" |
| | | 12 | | 6" | 6-1/4" | 6-3/4" | 7" |
| 9 | 7 | 24 | 2-1/2" | 2-3/4" | 3-1/4" | 3-1/2" | 4" |
| | | 16 | 3-3/4" | 4-1/4" | 4-1/2" | 5" | 5-1/2" |
| | | 12 | 4-1/2" | 6-1/4" | 6-1/2" | 7-1/4" | 8" |
| 10 | 7 | 24 | 2-1/2" | 3" | 3-1/2" | 3-3/4" | 4-1/2" |
| | | 16 | 3-3/4" | 4-1/2" | 5-1/4" | | |
| | | 12 | 5-1/4" | 6" | 7" | 7-1/2" | 8-1/2" |
| 11 | 7 | 24 | 2-1/2" | 3" | 3-1/2" | 4-1/4" | 4-3/4" |
| | | 16 | 4" | 5" | 6" | | |
| | | 12 | 5-1/2" | 6-1/2" | 7-1/2" | 9" | 10" |

Use for Model 1000 with disc mounted pockets

Assembly Instructions

For Model 1000 Series Transplanters

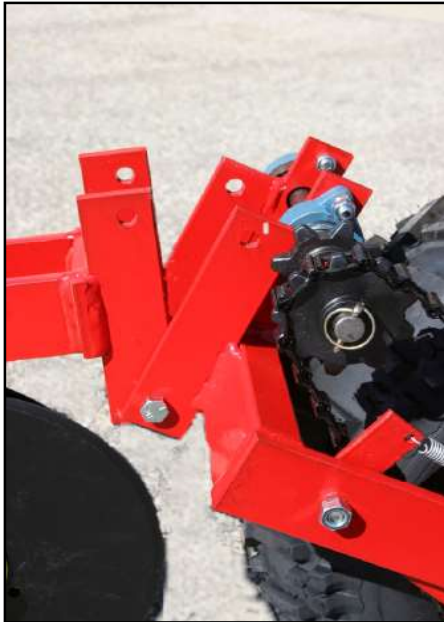

1. Bolt on the Direct Drive Float Wheel using the four 1/2 x 1-1/2 " bolts. Secure using the 1/2" hex nuts.



2. Remove the following parts from the direct drive wheel jackshaft: Clip pin, drive chain coming from the wheel, outside sprocket on jackshaft, and pipe spacer. Then remove the extra top hex nut located on the flange bearing.



3. Install the inside chain guard of the unit. Fasten front short tab to the top bolt on flange bearing from #2 photo with hex nut. The long tab attaches to the empty hole on the transplanter frame by the packing wheels. The guard must fit between the shoe brace and the guide adjustment bolt. Use the 3/8 x 1" bolt and a 3/8" hex nut to secure.

4. Select the proper sprocket arrangement for the spacing needed between plants. Look on page 2 or the chart on the side of your transplanter for the correct arrangement. For spacings using 11 tooth sprockets, extra chain links may be needed to lengthen the drive chain. These links are wired to the lift chain by the drive wheel. After finding the correct sprockets, run the long drive chain from the sprocket on the pocket chain shaft to the inside sprocket on the jackshaft of the direct drive wheel. The chain must go over the idler sprocket on the shoe brace and under the chain tightener sprocket as shown in the photo below.



5. Slide the red pipe spacer back onto the jackshaft. Insert the roll pin back into the second hole from the outside of the jackshaft. Slide the outside sprocket over the roll pin. Slide the drive chain coming from the drive wheel over the outside jackshaft sprocket. You may have to use your hand to push the chain tightener up to create enough slack in the chain. Insert the clip pin into the outside hole of the jackshaft.



6. Slide the outside chain guard onto the two pins and secure with clip pins.

Installation of Plant Stands

It is very important to know what row width will be used before installing the plant stands on multi-row transplanter. Follow the chart below.

- 42" Row Spacing - All Wide Plant Boxes
- 41" to 36" Row Spacing - Narrow Plant Boxes Inside
- 35" to 24" Row Spacing - One Wide Inside & Two Wide Outside
- 23" to 21" Row Spacing - One Narrow Inside & Two Wide Outside
- Less than 21" Row Spacing - Wide Outside Plant Boxes Only



1. Remove the long bolt between the uprights by the pocket chain. Do not lose the spacer between the uprights. Remove the outside cotter key in each axle.



2. Install the slotted mounting plates on both sides of the planter using the long bolt just removed. Do not tighten until the plant stand is fully assembled.



3. Slide plant stand onto the packing wheel axle and insert cotter key. Bend cotter key ends to keep in place.

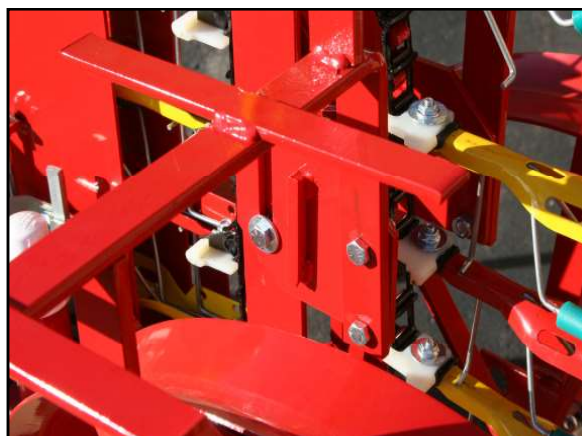

4. Use two 3/8 x 1" hex head bolts and two 3/8" nuts to attach plant stand frame to the slotted mounting bracket.



5. Attach the width adjustment plate with either the inside or outside hole depending on if you are using the wide (standard) plant boxes or the narrow with 3/8 x 1" hex head bolt and nut.



6. Install the plant boxes. These can be adjusted forward or backward for operator comfort.



Assembling the L-Shaped Seat Braces



1. Assemble the L-shaped seat brace by the chain guard. The sea brace mounts on the inside of the frame. The U-bolt mounts from the outside of the transplanter frame under the chain guard. Secure with 1/2" washers and 1/2" hex nuts over each threaded end.



2. The second L-shaped seat brace gets attached on the outside of the transplanter opposite the chain guard. The seat brace mounts on the outside of the frame with the U-bolt coming from the inside of the frame going outside through the seat brace. Secure with 1/2" washers and 1/2" hex nuts over each threaded end.

Mounting your Fiberglass or Cushion Seat

•Fiberglass Seats•



Fiberglass Seat - Turn your fiberglass seat over and remove any covers over the threaded studs. Take your green fiberglass seat bracket and mount it to the bottom of the seat with the side with the bend towards the front of the seat. Secure with four 1/4" hex nuts. Insert the 1/2 x 1-1/2 carriage bolt through the brace and then through the L-shaped seat bracket. Secure with a 1/2" washer and hex nut.

•Cushion Seats•

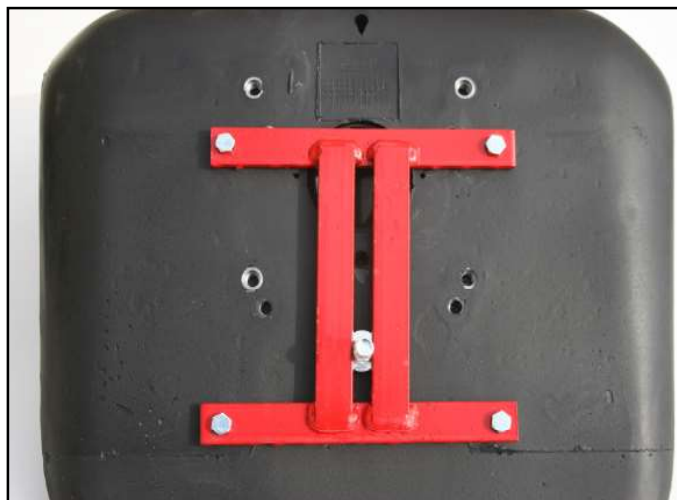

Cushion Seat - Slide the 1/2" x 1-1/2" carriage bolt through the bottom of the red seat bracket before mounting the seat bracket to the seat. After placing the carriage bolt through the seat bracket, place the seat bracket on the cushion seat. Secure with four 5/16" x 1" hex head bolts. Place the seat on the L-shaped seat bracket and secure with a 1/2" washer and hex nut.

Loose Pocket Assembly

If your Model 1000 was shipped in a crate, a pocket must be put on the empty attachment link.

The empty attachment link should be right at the top of the chain when the unit is shipped. If it is not, turn the drive wheel until the empty attachment link comes to the top.



Do NOT put #445 rubber gripper onto spring wires(#440) until pocket is assembled to attachment link.

Take the extra V-3 pocket that is wired onto unit and loosen the pocket bolt. Put pocket bolt through the attachment link. Make sure spacing bar stays under the head of the bolt. Place #375 water trip on the back of attachment link, then the 1/4" fender washer. Secure with 1/4" flange nut. After the bolt has been tightened, slide the top part of the #445 rubber gripper to the #440 wire.

Instructions for Direct Drive Clamps

The following instructions are for mounting the direct drive clamps to your Model 1000 unit. Although the pictures show the 2-1/2" clamps, use these instructions for any clamp style. They all mount the same way.



1. Insert a metal bushing from the inside of the frame. Put one of the 1/2 x 1-1/2" bolts through the bushing also from the inside.

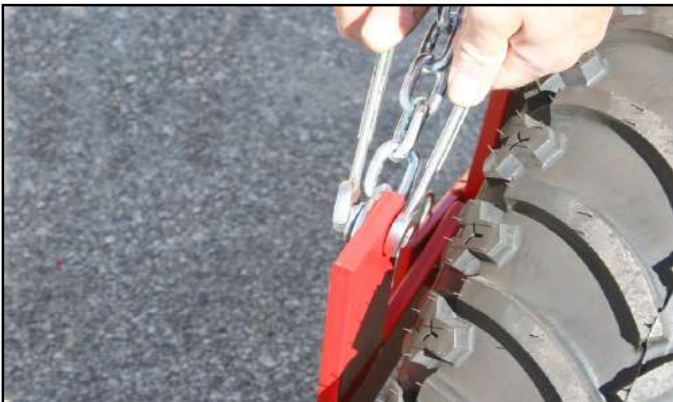

2. Attach the clamp to the bolt in the **top** hole of the bottom set of large holes. Secure with a 1/2" hex nut.
3. If you have a Model 1000B-3 or 1000-2 follow directions below for one clamp side only. To mount safety bar on other clamp side, see page 11. In the **top** set of holes, place a 7/16 x 1-1/4" bolt through the top hole.

4. Slide the end link of the chain onto the bolt.
5. Secure the chain with a 3/8" washer and then a 7/16" hex nut. Make sure the nut is very tight.





6. Use the same instructions for the other side of the Direct Drive Wheel.

Note: The clamps may be reversed or fastened on the inside of the frame for narrow row spacings. Also, if other clamps are in the way, two lefts or two rights may be used. The lower holes on the clamps are for higher toolbars on older models or on tractors where 3-point hitch will not go low enough. Correct height of toolbar is 14" to center.

The Model 1000 unit can now be mounted to your 3-point hitch or toolbar. Following is a list of fasteners that you must use for various toolbars.

Toolbar Hardware List

- 2-1/2" or 2-1/4" Diamond toolbar - 7/8" V-bend U-bolt (2)
- 3" x 3" Flat Toolbar - 3/4" x 5" Hex bolts (4)
- 4" x 4" Flat Toolbar - 3/4" x 6" Hex bolts (4)
- 4" x 7" Toolbar - 3/4" x 9-1/2" Hex bolts (4)
- 5" x 7" Toolbar - 3/4" x 7" Hex bolts (4)
- 7" x 7" Toolbar - 3/4" x 9-1/2" (4)



Shown with clamps reversed

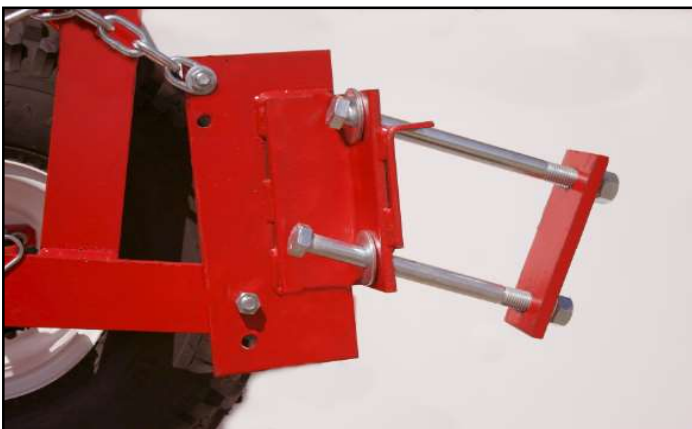

4 x 7 Toolbar Clamp. Use 2-3/4 x 9-1/2" hex bolts, 2-3/4" hex nuts and 2-3/4" washers.

Note: bent bracket on front of clamp

Model 1000B-3 Barrel Mounting & 3-Point Hitch Instructions



For B-3 Model, make sure the safety bar is properly installed!

To mount this safety bar, you must remove the 7/16 x 1-1/4" bolt from on side of the direct drive wheel.

1. Locate the special 2-1/2" stud in your bag of bolts and nuts.
2. Turn a 7/16" hex nut all the way onto the stud.
3. Put the 7/16" washer on the stud next to the nut.
4. Place the lift chain up against the washer.
5. Slide the stud through the hole on the Direct Drive frame and secure with a 7/16" hex nut.
6. Assemble another stud the same way and fasten it to the top hole of the front Direct Drive clamp.
7. Attach the red seat safety bar to the stud on your drive wheel. **The end with the hole must go on the clamp. The slotted end must go on the frame.** After the safety bar is attached, place the small clip pins through the small holes.

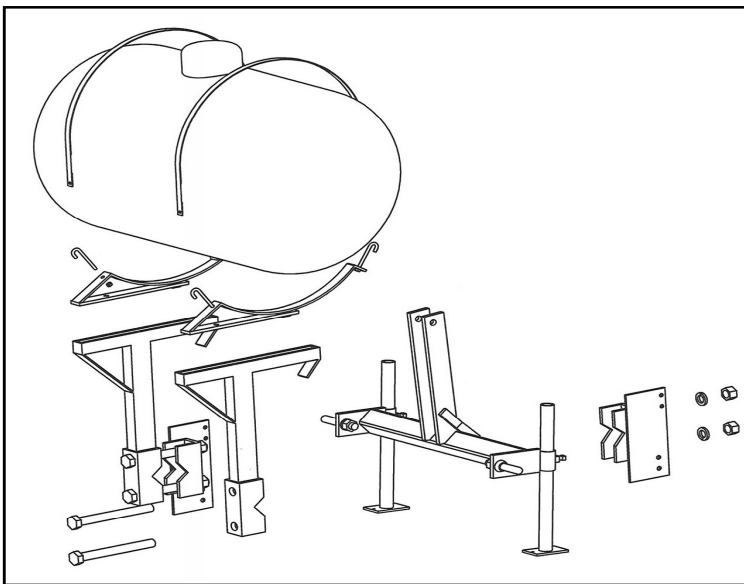

3-Point Hitch & Barrel Mounting

1. On the 3-point hitch, connect the Category I hitch pins through the holes on the outside of the hitch. Put the pins in through the outside and secure with the lock washer and hex nut included with the pin.
2. Slide the green pipe stands up through the pipes on the hitch, then tighten by turning the set screw.

Note: The following instructions will be easier with two people



3. Center the 3-point hitch toolbar with the clamps on your transplanter. Next, line up one of the barrel mounting brackets with the direct drive clamps. Secure using two 1 x 8-1/2 bolts and hex nuts. Do the same with the other barrel mounting bracket.



Side view of B-3 mountings



4. Bolt barrel hoops onto B-3 supports using 1/2 x 3" hex bolt with 1/2" lock nut. Note below: the hoops can be mounted in a forward or back position, depending on clearance that you need for the tractor fenders etc.



5. Screw in the nipple into the bottom of the tank.



6. Insert J-bolts into the four holes on the barrel hoops. It works best to thread 5/16" nut onto J-bolt before hooking up barrel hoops.



7. The 55 gallon poly tank can now be mounted on top of the barrel mountings. Use the four J-bolts and the galvanized straps to secure the barrel to the mountings.

A. Grease all fittings before the start of each day. Grease fittings are found:

1. On each packing wheel axle.
2. Upper pocket chain sprocket (Model 1000 only)
3. Direct drive tire hub (Direct Drive Units only)
4. On each nylon bushing on the pocket chain jackshaft.

B. Regulating Plant Depth

1. All operators should take care to see that the plants are placed well down in the pocket so the plant is held firmly.
2. The plant depth is regulated by the distance the root is extended out of the pocket.
3. To set the plants deeper, simply set the plant in the pocket with the roots further out than what is normally done. (See figure below)
4. If planting strawberries the axle must be raised up, allowing the transplanter unit to go deeper into the soil to cover the strawberry crowns.



V-3 Standard Plant Placement



Deeper Plant Placement

C. Pocket Chain Instructions

1. Make sure that bolts holding the upper sprocket on the pocket chain are not too tight. This will cause unnecessary friction on the unit and possible slippage on packing wheel drive transplanter. Simply loosen the wing nuts if the chain seems too tight.
2. Tighten the wing nuts equally by the top sprocket to keep the chain running level at all times.
3. If in row spacings of 20" or greater are needed, use only 6 pockets. You may remove every other pocket or leave them on. This gives the same speed or greater as a 12 pocket chain.

D. Adjusting or setting the #395R Round Point Shoe

Note: The shoe is preset at the factory for almost all situations.

Follow these instructions only if plants are leaning or in extreme wet or dry soil conditions.

1. Whenever any adjustments are made, be sure to get the shoe directly square and straight in front of the opening of the packing wheels. Make sure that the pockets will run through the middle of the shoe.
2. In loose dry soil, the shoe should be adjusted closer to the packing wheels. This can be done by adjusting the diagonal brace on the shoe.
3. In wet heavy soil, the shoe should be adjusted away from the packing wheels. Again, this can be done by adjusting the diagonal shoe brace.
4. Keep the shoe clean at all times. Do not allow dirt or trash to build up on the front or side of the shoe because this can cause too wide of a furrow that cannot be closed properly by the packing wheels. Poly covered shoes will eliminate this problem.

E. Water Valve Adjustment

1. For more water, make sure the valve is getting a full stroke by adjusting the #604 bracket on the pump rod. Make sure the valve does not over stroke. You should be able to lift the 604 rod 1/4-1/2" at the top of its stroke.
2. A broad range of adjustment can be achieved with the #603 water cam.
3. For wider spacings, the water cam may have to be raised so the water is on the plant. If the #603 is raised, be sure to raise the #604 water adjustment bracket accordingly and do not over stroke.

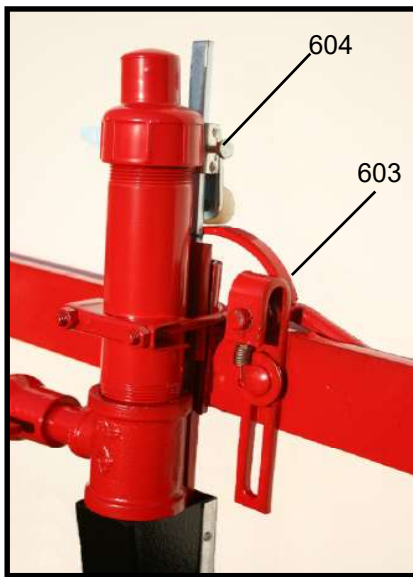

Example: At 20" row spacing, the #603 water cam should be adjusted nearly all the way up the slot. The #604 water adjustment must also be adjusted accordingly so a 1/2" remains on the 604 stroke.

4. Tilting the #603 water cam back towards the water trips on the pockets will create a longer stroke of water or more water before and after the plant.
5. Always empty the water out of the valve after quitting for the day. **Water freezing inside the valve will destroy the #610 and #612 balls inside the valve.**

F. Direct Drive Float Wheel Operation

1. Use only 4 to 5 pounds of air pressure in the Direct Drive Wheel during operation.



Wrong
Toolbar too high



Correct



Wrong
Toolbar too low

2. It is very important when starting to transplant, that the lift chains on the side of the Direct Drive Wheel are loose. See above "Correct" picture.
3. When lowering the transplanting unit into the ground, be sure that the frame members on the Direct Drive Wheel run parallel as is shown in the center picture. This is adjusted by the height of the hitch or toolbar (a pair of gauge wheels will eliminate adjustment of toolbar height).
4. Running the frame parallel will keep the lift chains loose allowing for proper floatation in the Direct Drive Wheel.
5. Running the frame members parallel and level will allow the packing wheels to run in the proper packing position.
6. Running the toolbar too low will tighten the back chains and cause the packing wheels to run too light and not pack the soil properly.
7. Running the toolbar too high will tighten the front lift chains and cause the Direct Drive Wheel to not run on the ground, especially through low spots.

Trouble Shooting

Important - Before attempting any of the following, make sure that the unit is running level or parallel to the ground. Do not run the front hitch or toolbar too far down or up. On all Model 1000 series units, make sure that the chains are loose on both sides of the arch bracket over the drive wheel. For all transplanter, make sure the soil is worked deep enough.

Problem

Solution

Packing wheels not packing properly

- A. Lengthen third arm on tractor to get float in hitch
- B. Hitch is too far down and needs to be lifted (lift chains are not loose)
- C. Clean off sides of shoe
- D. Work soil deeper
- E. Add weight to back of unit
- F. Poly shoes will eliminate soil building up on the outsides

Water leaks from top of water valve

- A. Check to see if the rubber nipple inside the top of the valve is in place and rounded.
- B. #610 ball inside the valve has collapsed and needs to be replaced.

Water leaks from bottom of water valve

- A. Rubber ball #612 on pin is broke and needs to be replaced
- B. The nylon nut on the bottom is broken and needs to be replaced

Water not uniform

- A. Make sure all the water trips on the pockets are in good shape and at even distances from the attachment link.
- B. Check to see that all springs on the water valve are in good working order.
- C. Water valve has dirt or residue build up that needs to be cleaned out

Water misses plants

•See water valve instructions on Page13.

Plants falling out of pocket

- A. Inspect the rubber grippers to make sure that they are not all stretched out.
- B. Tighten the L-bolts on the side of the guides.
- C. #482 pocket extensions may be needed if planting cell-type plants.
- D. Check bottom of guides to insure that the pocket is not releasing the plant too soon.

Plants on top of soil

- A. Cut back on water because the plants are floating up out of the shoe.
- B. Plants need to be pulled further out of the pocket to put them deeper.
- C. Too much loose soil is getting inside the shoe before the packing wheels can pack. Move shoe closer to packing wheels.
- D. A gap might be occurring by having the hitch too low causing the packing wheels to be up in the air or not being able to put enough pressure on the soil.
- E. Ground not worked deep enough causing the shoe to not go deep enough into the soil.

Plants leaning

- A. Need to put plant further in the pocket to keep it from hitting the bottom of the furrow.
- B. Possibility of needing a deeper shoe.
- C. May need #482 extensions to help support the cell of a plant coming from a tray.
- D. See Operating Instructions on Page 13 about adjusting the shoe.

Safety Precautions

1. Make sure tractor is stopped and in neutral with the transplanter lowered to the ground before getting on and off the unit.
2. No operator is allowed to be on the unit as it is raised and lowered.
3. No operator is allowed on the transplanter as it is transported to or from the field.
4. All operators must be seated before movement begins and remain seated until the transplanter is completely stopped.
5. Never leave the transplanter in the raised position.
6. Keep all shields and guards in place when operating the transplanter.
7. Never attempt repairs or maintenance while the transplanter is in motion.
8. Never put the tractor in reverse while the transplanter is on the ground.
9. Follow all safety instructions supplied by the tractor manufacturer to which the transplanter is mounted.

MACHINE IMPROVEMENTS

MECHANICAL TRANSPLANTER CO. IS ALWAYS STRIVING TO MAKE IMPROVEMENTS ON THEIR LINE OF EQUIPMENT. MECHANICAL TRANSPLANTER CO. RESERVES THE RIGHT TO MAKE IMPROVEMENTS AND CHANGES AT ANY TIME WITHOUT INCURRING OBLIGATIONS TO MAKE SUCH CHANGES OR ADDITIONS TO EQUIPMENT PREVIOUSLY SOLD.

Limited Warranty

Mechanical Transplanter Company warrants each item of new equipment manufactured by Mechanical to be free from defects in material and workmanship under normal use and service.

The obligation of Mechanical Transplanter Company under this LIMITED WARRANTY is limited to repairing or replacing as Mechanical may elect, and any parts that prove, in Mechanical's judgment, to be defective in material and workmanship within the first season's use or 45 consecutive days after initially placing equipment in operation, whichever occurs first. Any outside work or alterations without Mechanical's written approval will render the LIMITED WARRANTY void.

Mechanical's obligation specifically excludes any liability for consequential damages, such as loss of profits, delays, expenses, damage to goods or property used in connection with or processed in or by the product sold, or damage to the product sold from whatsoever cause, whether or not such loss is due to negligence of selling dealer of Mechanical Transplanter Company.

This limited warranty shall not apply to any item or machine which shall have been operated in a manner not recommended by the Company nor which shall have been repaired, altered, misused, damaged in an accident, neglected, tampered with or used in any way which in the Company's opinion adversely affects its performance and results.

No person is authorized to give any other warranties or to assume any other liability on behalf of Mechanical Transplanter Company, unless made in writing by Mechanical.

This limited warranty covers repair or replacement of Mechanical Transplanter Co. equipment only and does not cover crop loss, downtime, labor, damage to other equipment, etc.

This limited warranty does not apply to exterior finishes, tires, chain links, bearings, or any other items sold by Mechanical Transplanter Co., but warranted by the original manufacturer except to the extent of their individual manufacturer's warranty.

THIS LIMITED WARRANTY IS IN LIEU OF ALL OTHER WARRANTIES, EXPRESSED OR IMPLIED. WARRANTIES OF MERCHANTABILITY AND FITNESS FOR PARTICULAR PURPOSE ARE EXCLUDED, AS ARE ALL OTHER REPRESENTATIONS TO THE USER-PURCHASER, AND ALL OTHER OBLIGATIONS OR LIABILITIES, INCLUDING LIABILITY FOR INCIDENTAL AND CONSEQUENTIAL DAMAGES, ON THE PART OF MECHANICAL OR THE SELLER.

Mechanical Transplanter Co.

Model 1000 and 1000B-3

Operators Manual



Mechanical Transplanter Co., LLC
1150 Central Avenue • Holland, MI 49423-5230
Phone: 616-396-8738 • Fax: 616-396-3619
website: www.mechanicaltransplanter.com
e-mail: mtc@mechanicaltransplanter.com

Spacing Charts and Information

| SPACING CHART FOR DIRECT DRIVE UNIT W/ 12 POCKET CHAIN | | | | | | |
|---|---------------------------------|-------------------------------------|-----------------------|-----------------------|-------------------|-----------------|
| Sprocket on OUT-SIDE of Jackshaft | Sprocket on INSIDE of Jackshaft | Number of Teeth on Sprocket on Unit | | | | |
| | | 7 | 8 | 9 | 10 | 11 |
| 7 | 11 | 6" 15.2cm | 6-1/2" - 7" 17.8cm | 7-1/2" - 8" 20.3cm | 8-1/2" 21.6cm | 9" 22.8cm |
| 7 | 7 | 9" 22.8cm | 10-1/2" 26.7cm | 13" 33cm | 15" 38.1cm | 16" 40.6cm |
| 8 | 7 | 10-1/2" 26.7cm | 12-1/2" 31.7cm | 14" 35.5cm | 15" 38.1cm | 16" 40.6cm |
| 9 | 7 | 12" 30.5cm | 13-1/2" 34.3cm | 15" 38.1cm | 17" 43.2cm | 18-1/2" 47cm |
| 10 | 7 | 13" 33cm | 14" 35.5cm | 15-1/2" 39.4cm | 17-1/2" 44.5cm | 20-1/2" 52cm |
| 11 | 7 | 15" 38.1cm | 18" 45.7cm | | | |

Double any of the above spacings by using every other pocket (6 pocket).
Make sure HITCH and UNIT are level or parallel to the ground when planting.

Use for Model 1000

| DISC SPACING CHART FOR MODELS W/ DIRECT DRIVE | | | | | | | |
|--|---------------------------------|-------------------------------|-------------------------------------|--------|--------|--------|--------|
| Sprocket on OUTSIDE of Jackshaft | Sprocket on INSIDE of Jackshaft | Number of Pockets on the Disc | Number of Teeth on Sprocket by Disc | | | | |
| | | | 7 | 8 | 9 | 10 | 11 |
| 7 | 7 | 24 | | 2" | 2-1/4" | 2-1/2" | 2-3/4" |
| | | 16 | 3" | 3-1/4" | 3-1/2" | 4" | 4-1/2" |
| | | 12 | | 4-3/4" | 5-1/4" | 5-3/4" | 6-1/4" |
| 8 | 7 | 24 | | 2-1/2" | 3" | 3-1/4" | 3-1/2" |
| | | 16 | 3-1/2" | 3-3/4" | 4-1/4" | 4-1/2" | 5-1/4" |
| | | 12 | | 6" | 6-1/4" | 6-3/4" | 7" |
| 9 | 7 | 24 | 2-1/2" | 2-3/4" | 3-1/4" | 3-1/2" | 4" |
| | | 16 | 3-3/4" | 4-1/4" | 4-1/2" | 5" | 5-1/2" |
| | | 12 | 4-1/2" | 6-1/4" | 6-1/2" | 7-1/4" | 8" |
| 10 | 7 | 24 | 2-1/2" | 3" | 3-1/2" | 3-3/4" | 4-1/2" |
| | | 16 | 3-3/4" | 4-1/2" | 5-1/4" | | |
| | | 12 | 5-1/4" | 6" | 7" | 7-1/2" | 8-1/2" |
| 11 | 7 | 24 | 2-1/2" | 3" | 3-1/2" | 4-1/4" | 4-3/4" |
| | | 16 | 4" | 5" | 6" | | |
| | | 12 | 5-1/2" | 6-1/2" | 7-1/2" | 9" | 10" |

Use for Model 1000 with disc mounted pockets

Assembly Instructions

For Model 1000 Series Transplanters

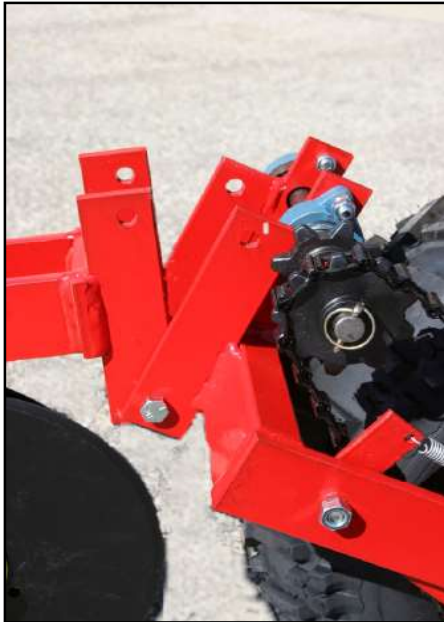

1. Bolt on the Direct Drive Float Wheel using the four 1/2 x 1-1/2 " bolts. Secure using the 1/2" hex nuts.



2. Remove the following parts from the direct drive wheel jackshaft: Clip pin, drive chain coming from the wheel, outside sprocket on jackshaft, and pipe spacer. Then remove the extra top hex nut located on the flange bearing.



3. Install the inside chain guard of the unit. Fasten front short tab to the top bolt on flange bearing from #2 photo with hex nut. The long tab attaches to the empty hole on the transplanter frame by the packing wheels. The guard must fit between the shoe brace and the guide adjustment bolt. Use the 3/8 x 1" bolt and a 3/8" hex nut to secure.

4. Select the proper sprocket arrangement for the spacing needed between plants. Look on page 2 or the chart on the side of your transplanter for the correct arrangement. For spacings using 11 tooth sprockets, extra chain links may be needed to lengthen the drive chain. These links are wired to the lift chain by the drive wheel. After finding the correct sprockets, run the long drive chain from the sprocket on the pocket chain shaft to the inside sprocket on the jackshaft of the direct drive wheel. The chain must go over the idler sprocket on the shoe brace and under the chain tightener sprocket as shown in the photo below.



5. Slide the red pipe spacer back onto the jackshaft. Insert the roll pin back into the second hole from the outside of the jackshaft. Slide the outside sprocket over the roll pin. Slide the drive chain coming from the drive wheel over the outside jackshaft sprocket. You may have to use your hand to push the chain tightener up to create enough slack in the chain. Insert the clip pin into the outside hole of the jackshaft.



6. Slide the outside chain guard onto the two pins and secure with clip pins.

Installation of Plant Stands

It is very important to know what row width will be used before installing the plant stands on multi-row transplanter. Follow the chart below.

- 42" Row Spacing - All Wide Plant Boxes
- 41" to 36" Row Spacing - Narrow Plant Boxes Inside
- 35" to 24" Row Spacing - One Wide Inside & Two Wide Outside
- 23" to 21" Row Spacing - One Narrow Inside & Two Wide Outside
- Less than 21" Row Spacing - Wide Outside Plant Boxes Only



1. Remove the long bolt between the uprights by the pocket chain. Do not lose the spacer between the uprights. Remove the outside cotter key in each axle.



2. Install the slotted mounting plates on both sides of the planter using the long bolt just removed. Do not tighten until the plant stand is fully assembled.



3. Slide plant stand onto the packing wheel axle and insert cotter key. Bend cotter key ends to keep in place.

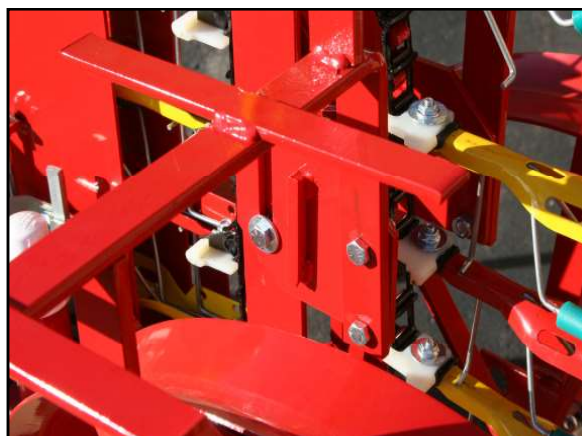

4. Use two 3/8 x 1" hex head bolts and two 3/8" nuts to attach plant stand frame to the slotted mounting bracket.



5. Attach the width adjustment plate with either the inside or outside hole depending on if you are using the wide (standard) plant boxes or the narrow with 3/8 x 1" hex head bolt and nut.

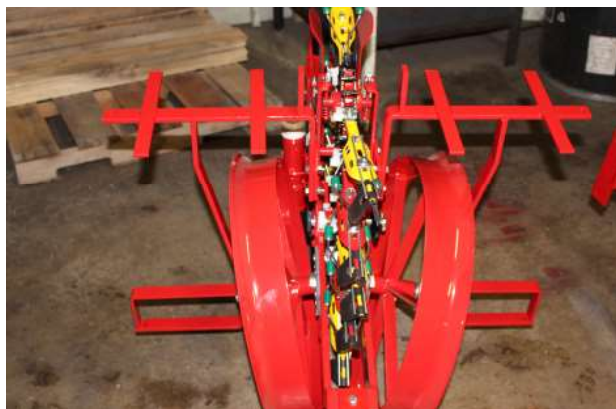

6. Install the plant boxes. These can be adjusted forward or backward for operator comfort.



Assembling the L-Shaped Seat Braces



1. Assemble the L-shaped seat brace by the chain guard. The sea brace mounts on the inside of the frame. The U-bolt mounts from the outside of the transplanter frame under the chain guard. Secure with 1/2" washers and 1/2" hex nuts over each threaded end.



2. The second L-shaped seat brace gets attached on the outside of the transplanter opposite the chain guard. The seat brace mounts on the outside of the frame with the U-bolt coming from the inside of the frame going outside through the seat brace. Secure with 1/2" washers and 1/2" hex nuts over each threaded end.

Mounting your Fiberglass or Cushion Seat

•Fiberglass Seats•



Fiberglass Seat - Turn your fiberglass seat over and remove any covers over the threaded studs. Take your green fiberglass seat bracket and mount it to the bottom of the seat with the side with the bend towards the front of the seat. Secure with four 1/4" hex nuts. Insert the 1/2 x 1-1/2 carriage bolt through the brace and then through the L-shaped seat bracket. Secure with a 1/2" washer and hex nut.

•Cushion Seats•

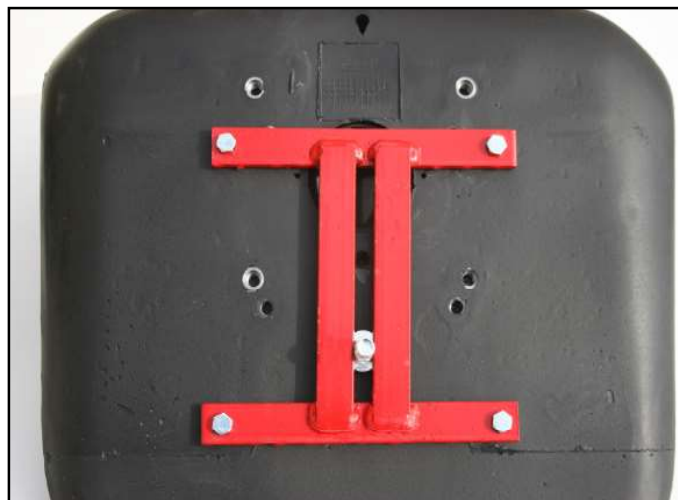

Cushion Seat - Slide the 1/2" x 1-1/2" carriage bolt through the bottom of the red seat bracket before mounting the seat bracket to the seat. After placing the carriage bolt through the seat bracket, place the seat on the L-shaped seat bracket and secure with a 1/2" washer and hex nut.

Loose Pocket Assembly

If your Model 1000 was shipped in a crate, a pocket must be put on the empty attachment link.

The empty attachment link should be right at the top of the chain when the unit is shipped. If it is not, turn the drive wheel until the empty attachment link comes to the top.



Do NOT put #445 rubber gripper onto spring wires(#440) until pocket is assembled to attachment link.

Take the extra V-3 pocket that is wired onto unit and loosen the pocket bolt. Put pocket bolt through the attachment link. Make sure spacing bar stays under the head of the bolt. Place #375 water trip on the back of attachment link, then the 1/4" fender washer. Secure with 1/4" flange nut. After the bolt has been tightened, slide the top part of the #445 rubber gripper to the #440 wire.

Instructions for Direct Drive Clamps

The following instructions are for mounting the direct drive clamps to your Model 1000 unit. Although the pictures show the 2-1/2" clamps, use these instructions for any clamp style. They all mount the same way.



1. Insert a metal bushing from the inside of the frame. Put one of the 1/2 x 1-1/2" bolts through the bushing also from the inside.



2. Attach the clamp to the bolt in the **top** hole of the bottom set of large holes. Secure with a 1/2" hex nut.
3. If you have a Model 1000B-3 or 1000-2 follow directions below for one clamp side only. To mount safety bar on other clamp side, see page 11. In the **top** set of holes, place a 7/16 x 1-1/4" bolt through the top hole.

4. Slide the end link of the chain onto the bolt.
5. Secure the chain with a 3/8" washer and then a 7/16" hex nut. Make sure the nut is very tight.





6. Use the same instructions for the other side of the Direct Drive Wheel.

Note: The clamps may be reversed or fastened on the inside of the frame for narrow row spacings. Also, if other clamps are in the way, two lefts or two rights may be used. The lower holes on the clamps are for higher toolbars on older models or on tractors where 3-point hitch will not go low enough. Correct height of toolbar is 14" to center.

The Model 1000 unit can now be mounted to your 3-point hitch or toolbar. Following is a list of fasteners that you must use for various toolbars.

Toolbar Hardware List

- 2-1/2" or 2-1/4" Diamond toolbar - 7/8" V-bend U-bolt (2)
- 3" x 3" Flat Toolbar - 3/4" x 5" Hex bolts (4)
- 4" x 4" Flat Toolbar - 3/4" x 6" Hex bolts (4)
- 4" x 7" Toolbar - 3/4" x 9-1/2" Hex bolts (4)
- 5" x 7" Toolbar - 3/4" x 7" Hex bolts (4)
- 7" x 7" Toolbar - 3/4" x 9-1/2" (4)



Shown with clamps reversed

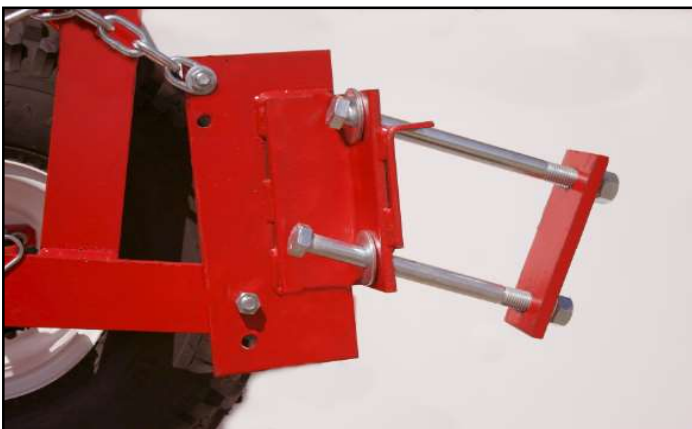

4 x 7 Toolbar Clamp. Use 2-3/4 x 9-1/2" hex bolts, 2-3/4" hex nuts and 2-3/4" washers.

Note: bent bracket on front of clamp

Model 1000B-3 Barrel Mounting & 3-Point Hitch Instructions



For B-3 Model, make sure the safety bar is properly installed!

To mount this safety bar, you must remove the 7/16 x 1-1/4" bolt from on side of the direct drive wheel.

1. Locate the special 2-1/2" stud in your bag of bolts and nuts.
2. Turn a 7/16" hex nut all the way onto the stud.
3. Put the 7/16" washer on the stud next to the nut.
4. Place the lift chain up against the washer.
5. Slide the stud through the hole on the Direct Drive frame and secure with a 7/16" hex nut.
6. Assemble another stud the same way and fasten it to the top hole of the front Direct Drive clamp.
7. Attach the red seat safety bar to the stud on your drive wheel. **The end with the hole must go on the clamp. The slotted end must go on the frame.** After the safety bar is attached, place the small clip pins through the small holes.

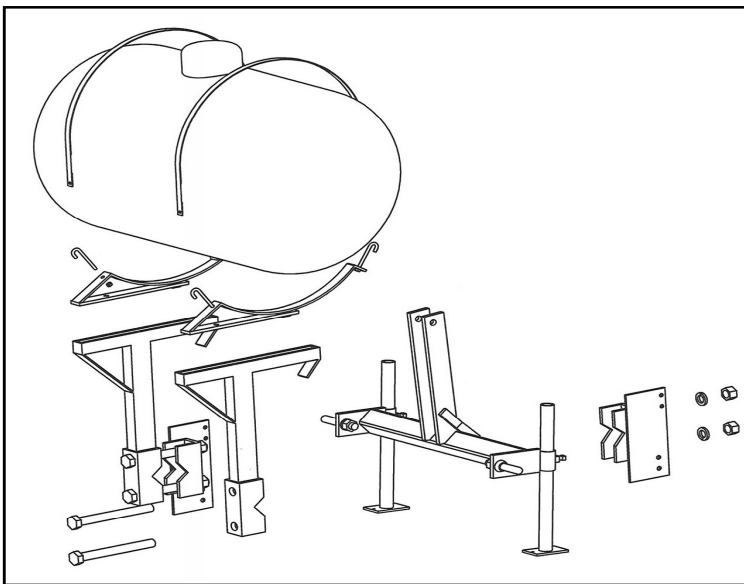

3-Point Hitch & Barrel Mounting

1. On the 3-point hitch, connect the Category I hitch pins through the holes on the outside of the hitch. Put the pins in through the outside and secure with the lock washer and hex nut included with the pin.
2. Slide the green pipe stands up through the pipes on the hitch, then tighten by turning the set screw.

Note: The following instructions will be easier with two people



3. Center the 3-point hitch toolbar with the clamps on your transplanter. Next, line up one of the barrel mounting brackets with the direct drive clamps. Secure using two 1 x 8-1/2 bolts and hex nuts. Do the same with the other barrel mounting bracket.



Side view of B-3 mountings



4. Bolt barrel hoops onto B-3 supports using 1/2 x 3" hex bolt with 1/2" lock nut. Note below: the hoops can be mounted in a forward or back position, depending on clearance that you need for the tractor fenders etc.



5. Screw in the nipple into the bottom of the tank.



6. Insert J-bolts into the four holes on the barrel hoops. It works best to thread 5/16" nut onto J-bolt before hooking up barrel hoops.



7. The 55 gallon poly tank can now be mounted on top of the barrel mountings. Use the four J-bolts and the galvanized straps to secure the barrel to the mountings.

A. Grease all fittings before the start of each day. Grease fittings are found:

1. On each packing wheel axle.
2. Upper pocket chain sprocket (Model 1000 only)
3. Direct drive tire hub (Direct Drive Units only)
4. On each nylon bushing on the pocket chain jackshaft.

B. Regulating Plant Depth

1. All operators should take care to see that the plants are placed well down in the pocket so the plant is held firmly.
2. The plant depth is regulated by the distance the root is extended out of the pocket.
3. To set the plants deeper, simply set the plant in the pocket with the roots further out than what is normally done. (See figure below)
4. If planting strawberries the axle must be raised up, allowing the transplanter unit to go deeper into the soil to cover the strawberry crowns.



V-3 Standard Plant Placement



Deeper Plant Placement

C. Pocket Chain Instructions

1. Make sure that bolts holding the upper sprocket on the pocket chain are not too tight. This will cause unnecessary friction on the unit and possible slippage on packing wheel drive transplanter. Simply loosen the wing nuts if the chain seems too tight.
2. Tighten the wing nuts equally by the top sprocket to keep the chain running level at all times.
3. If in row spacings of 20" or greater are needed, use only 6 pockets. You may remove every other pocket or leave them on. This gives the same speed or greater as a 12 pocket chain.

D. Adjusting or setting the #395R Round Point Shoe

Note: The shoe is preset at the factory for almost all situations.

Follow these instructions only if plants are leaning or in extreme wet or dry soil conditions.

1. Whenever any adjustments are made, be sure to get the shoe directly square and straight in front of the opening of the packing wheels. Make sure that the pockets will run through the middle of the shoe.
2. In loose dry soil, the shoe should be adjusted closer to the packing wheels. This can be done by adjusting the diagonal brace on the shoe.
3. In wet heavy soil, the shoe should be adjusted away from the packing wheels. Again, this can be done by adjusting the diagonal shoe brace.
4. Keep the shoe clean at all times. Do not allow dirt or trash to build up on the front or side of the shoe because this can cause too wide of a furrow that cannot be closed properly by the packing wheels. Poly covered shoes will eliminate this problem.

E. Water Valve Adjustment

1. For more water, make sure the valve is getting a full stroke by adjusting the #604 bracket on the pump rod. Make sure the valve does not over stroke. You should be able to lift the 604 rod 1/4-1/2" at the top of its stroke.
2. A broad range of adjustment can be achieved with the #603 water cam.
3. For wider spacings, the water cam may have to be raised so the water is on the plant. If the #603 is raised, be sure to raise the #604 water adjustment bracket accordingly and do not over stroke.

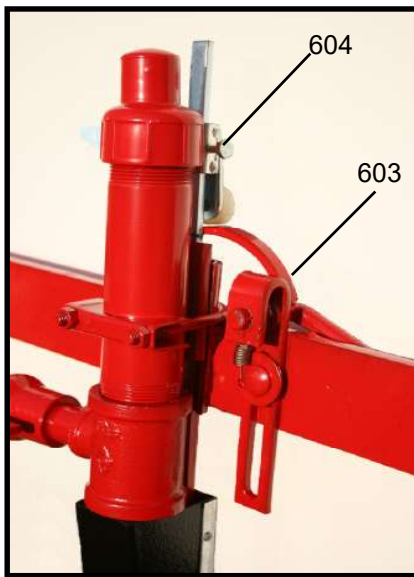

Example: At 20" row spacing, the #603 water cam should be adjusted nearly all the way up the slot. The #604 water adjustment must also be adjusted accordingly so a 1/2" remains on the 604 stroke.

4. Tilting the #603 water cam back towards the water trips on the pockets will create a longer stroke of water or more water before and after the plant.
5. Always empty the water out of the valve after quitting for the day. **Water freezing inside the valve will destroy the #610 and #612 balls inside the valve.**

F. Direct Drive Float Wheel Operation

1. Use only 4 to 5 pounds of air pressure in the Direct Drive Wheel during operation.



Wrong
Toolbar too high



Correct



Wrong
Toolbar too low

2. It is very important when starting to transplant, that the lift chains on the side of the Direct Drive Wheel are loose. See above "Correct" picture.
3. When lowering the transplanting unit into the ground, be sure that the frame members on the Direct Drive Wheel run parallel as is shown in the center picture. This is adjusted by the height of the hitch or toolbar (a pair of gauge wheels will eliminate adjustment of toolbar height).
4. Running the frame parallel will keep the lift chains loose allowing for proper floatation in the Direct Drive Wheel.
5. Running the frame members parallel and level will allow the packing wheels to run in the proper packing position.
6. Running the toolbar too low will tighten the back chains and cause the packing wheels to run too light and not pack the soil properly.
7. Running the toolbar too high will tighten the front lift chains and cause the Direct Drive Wheel to not run on the ground, especially through low spots.

Trouble Shooting

Important - Before attempting any of the following, make sure that the unit is running level or parallel to the ground. Do not run the front hitch or toolbar too far down or up. On all Model 1000 series units, make sure that the chains are loose on both sides of the arch bracket over the drive wheel. For all transplanter, make sure the soil is worked deep enough.

Problem

Solution

Packing wheels not packing properly

- A. Lengthen third arm on tractor to get float in hitch
- B. Hitch is too far down and needs to be lifted (lift chains are not loose)
- C. Clean off sides of shoe
- D. Work soil deeper
- E. Add weight to back of unit
- F. Poly shoes will eliminate soil building up on the outsides

Water leaks from top of water valve

- A. Check to see if the rubber nipple inside the top of the valve is in place and rounded.
- B. #610 ball inside the valve has collapsed and needs to be replaced.

Water leaks from bottom of water valve

- A. Rubber ball #612 on pin is broke and needs to be replaced
- B. The nylon nut on the bottom is broken and needs to be replaced

Water not uniform

- A. Make sure all the water trips on the pockets are in good shape and at even distances from the attachment link.
- B. Check to see that all springs on the water valve are in good working order.
- C. Water valve has dirt or residue build up that needs to be cleaned out

Water misses plants

•See water valve instructions on Page13.

Plants falling out of pocket

- A. Inspect the rubber grippers to make sure that they are not all stretched out.
- B. Tighten the L-bolts on the side of the guides.
- C. #482 pocket extensions may be needed if planting cell-type plants.
- D. Check bottom of guides to insure that the pocket is not releasing the plant too soon.

Plants on top of soil

- A. Cut back on water because the plants are floating up out of the shoe.
- B. Plants need to be pulled further out of the pocket to put them deeper.
- C. Too much loose soil is getting inside the shoe before the packing wheels can pack. Move shoe closer to packing wheels.
- D. A gap might be occurring by having the hitch too low causing the packing wheels to be up in the air or not being able to put enough pressure on the soil.
- E. Ground not worked deep enough causing the shoe to not go deep enough into the soil.

Plants leaning

- A. Need to put plant further in the pocket to keep it from hitting the bottom of the furrow.
- B. Possibility of needing a deeper shoe.
- C. May need #482 extensions to help support the cell of a plant coming from a tray.
- D. See Operating Instructions on Page 13 about adjusting the shoe.

Safety Precautions

1. Make sure tractor is stopped and in neutral with the transplanter lowered to the ground before getting on and off the unit.
2. No operator is allowed to be on the unit as it is raised and lowered.
3. No operator is allowed on the transplanter as it is transported to or from the field.
4. All operators must be seated before movement begins and remain seated until the transplanter is completely stopped.
5. Never leave the transplanter in the raised position.
6. Keep all shields and guards in place when operating the transplanter.
7. Never attempt repairs or maintenance while the transplanter is in motion.
8. Never put the tractor in reverse while the transplanter is on the ground.
9. Follow all safety instructions supplied by the tractor manufacturer to which the transplanter is mounted.

MACHINE IMPROVEMENTS

MECHANICAL TRANSPLANTER CO. IS ALWAYS STRIVING TO MAKE IMPROVEMENTS ON THEIR LINE OF EQUIPMENT. MECHANICAL TRANSPLANTER CO. RESERVES THE RIGHT TO MAKE IMPROVEMENTS AND CHANGES AT ANY TIME WITHOUT INCURRING OBLIGATIONS TO MAKE SUCH CHANGES OR ADDITIONS TO EQUIPMENT PREVIOUSLY SOLD.

Limited Warranty

Mechanical Transplanter Company warrants each item of new equipment manufactured by Mechanical to be free from defects in material and workmanship under normal use and service.

The obligation of Mechanical Transplanter Company under this LIMITED WARRANTY is limited to repairing or replacing as Mechanical may elect, and any parts that prove, in Mechanical's judgment, to be defective in material and workmanship within the first season's use or 45 consecutive days after initially placing equipment in operation, whichever occurs first. Any outside work or alterations without Mechanical's written approval will render the LIMITED WARRANTY void.

Mechanical's obligation specifically excludes any liability for consequential damages, such as loss of profits, delays, expenses, damage to goods or property used in connection with or processed in or by the product sold, or damage to the product sold from whatsoever cause, whether or not such loss is due to negligence of selling dealer of Mechanical Transplanter Company.

This limited warranty shall not apply to any item or machine which shall have been operated in a manner not recommended by the Company nor which shall have been repaired, altered, misused, damaged in an accident, neglected, tampered with or used in any way which in the Company's opinion adversely affects its performance and results.

No person is authorized to give any other warranties or to assume any other liability on behalf of Mechanical Transplanter Company, unless made in writing by Mechanical.

This limited warranty covers repair or replacement of Mechanical Transplanter Co. equipment only and does not cover crop loss, downtime, labor, damage to other equipment, etc.

This limited warranty does not apply to exterior finishes, tires, chain links, bearings, or any other items sold by Mechanical Transplanter Co., but warranted by the original manufacturer except to the extent of their individual manufacturer's warranty.

THIS LIMITED WARRANTY IS IN LIEU OF ALL OTHER WARRANTIES, EXPRESSED OR IMPLIED. WARRANTIES OF MERCHANTABILITY AND FITNESS FOR PARTICULAR PURPOSE ARE EXCLUDED, AS ARE ALL OTHER REPRESENTATIONS TO THE USER-PURCHASER, AND ALL OTHER OBLIGATIONS OR LIABILITIES, INCLUDING LIABILITY FOR INCIDENTAL AND CONSEQUENTIAL DAMAGES, ON THE PART OF MECHANICAL OR THE SELLER.

Mechanical Transplanter Co.

Model 1000 and 1000B-3

Operators Manual



Mechanical Transplanter Co., LLC
1150 Central Avenue • Holland, MI 49423-5230
Phone: 616-396-8738 • Fax: 616-396-3619
website: www.mechanicaltransplanter.com
e-mail: mtc@mechanicaltransplanter.com

Spacing Charts and Information

| SPACING CHART FOR DIRECT DRIVE UNIT W/ 12 POCKET CHAIN | | | | | | |
|---|---------------------------------|-------------------------------------|-----------------------|-----------------------|-------------------|-----------------|
| Sprocket on OUT-SIDE of Jackshaft | Sprocket on INSIDE of Jackshaft | Number of Teeth on Sprocket on Unit | | | | |
| | | 7 | 8 | 9 | 10 | 11 |
| 7 | 11 | 6" 15.2cm | 6-1/2" - 7" 17.8cm | 7-1/2" - 8" 20.3cm | 8-1/2" 21.6cm | 9" 22.8cm |
| 7 | 7 | 9" 22.8cm | 10-1/2" 26.7cm | 13" 33cm | 15" 38.1cm | 16" 40.6cm |
| 8 | 7 | 10-1/2" 26.7cm | 12-1/2" 31.7cm | 14" 35.5cm | 15" 38.1cm | 16" 40.6cm |
| 9 | 7 | 12" 30.5cm | 13-1/2" 34.3cm | 15" 38.1cm | 17" 43.2cm | 18-1/2" 47cm |
| 10 | 7 | 13" 33cm | 14" 35.5cm | 15-1/2" 39.4cm | 17-1/2" 44.5cm | 20-1/2" 52cm |
| 11 | 7 | 15" 38.1cm | 18" 45.7cm | | | |

Double any of the above spacings by using every other pocket (6 pocket).
Make sure HITCH and UNIT are level or parallel to the ground when planting.

Use for Model 1000

| DISC SPACING CHART FOR MODELS W/ DIRECT DRIVE | | | | | | | |
|--|---------------------------------|-------------------------------|-------------------------------------|--------|--------|--------|--------|
| Sprocket on OUTSIDE of Jackshaft | Sprocket on INSIDE of Jackshaft | Number of Pockets on the Disc | Number of Teeth on Sprocket by Disc | | | | |
| | | | 7 | 8 | 9 | 10 | 11 |
| 7 | 7 | 24 | | 2" | 2-1/4" | 2-1/2" | 2-3/4" |
| | | 16 | 3" | 3-1/4" | 3-1/2" | 4" | 4-1/2" |
| | | 12 | | 4-3/4" | 5-1/4" | 5-3/4" | 6-1/4" |
| 8 | 7 | 24 | | 2-1/2" | 3" | 3-1/4" | 3-1/2" |
| | | 16 | 3-1/2" | 3-3/4" | 4-1/4" | 4-1/2" | 5-1/4" |
| | | 12 | | 6" | 6-1/4" | 6-3/4" | 7" |
| 9 | 7 | 24 | 2-1/2" | 2-3/4" | 3-1/4" | 3-1/2" | 4" |
| | | 16 | 3-3/4" | 4-1/4" | 4-1/2" | 5" | 5-1/2" |
| | | 12 | 4-1/2" | 6-1/4" | 6-1/2" | 7-1/4" | 8" |
| 10 | 7 | 24 | 2-1/2" | 3" | 3-1/2" | 3-3/4" | 4-1/2" |
| | | 16 | 3-3/4" | 4-1/2" | 5-1/4" | | |
| | | 12 | 5-1/4" | 6" | 7" | 7-1/2" | 8-1/2" |
| 11 | 7 | 24 | 2-1/2" | 3" | 3-1/2" | 4-1/4" | 4-3/4" |
| | | 16 | 4" | 5" | 6" | | |
| | | 12 | 5-1/2" | 6-1/2" | 7-1/2" | 9" | 10" |

Use for Model 1000 with disc mounted pockets

Assembly Instructions

For Model 1000 Series Transplanters

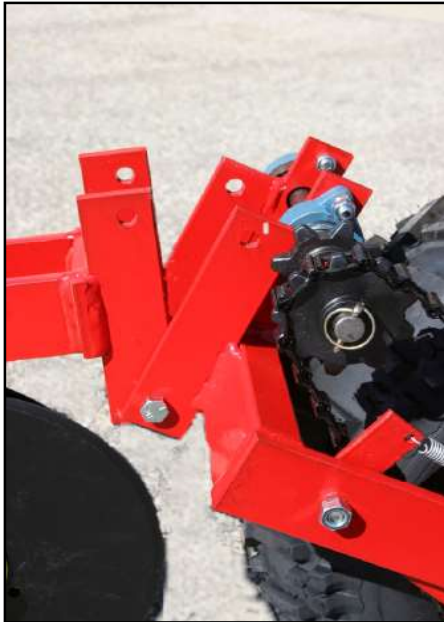

1. Bolt on the Direct Drive Float Wheel using the four 1/2 x 1-1/2 " bolts. Secure using the 1/2" hex nuts.



2. Remove the following parts from the direct drive wheel jackshaft: Clip pin, drive chain coming from the wheel, outside sprocket on jackshaft, and pipe spacer. Then remove the extra top hex nut located on the flange bearing.



3. Install the inside chain guard of the unit. Fasten front short tab to the top bolt on flange bearing from #2 photo with hex nut. The long tab attaches to the empty hole on the transplanter frame by the packing wheels. The guard must fit between the shoe brace and the guide adjustment bolt. Use the 3/8 x 1" bolt and a 3/8" hex nut to secure.

4. Select the proper sprocket arrangement for the spacing needed between plants. Look on page 2 or the chart on the side of your transplanter for the correct arrangement. For spacings using 11 tooth sprockets, extra chain links may be needed to lengthen the drive chain. These links are wired to the lift chain by the drive wheel. After finding the correct sprockets, run the long drive chain from the sprocket on the pocket chain shaft to the inside sprocket on the jackshaft of the direct drive wheel. The chain must go over the idler sprocket on the shoe brace and under the chain tightener sprocket as shown in the photo below.



5. Slide the red pipe spacer back onto the jackshaft. Insert the roll pin back into the second hole from the outside of the jackshaft. Slide the outside sprocket over the roll pin. Slide the drive chain coming from the drive wheel over the outside jackshaft sprocket. You may have to use your hand to push the chain tightener up to create enough slack in the chain. Insert the clip pin into the outside hole of the jackshaft.



6. Slide the outside chain guard onto the two pins and secure with clip pins.

Installation of Plant Stands

It is very important to know what row width will be used before installing the plant stands on multi-row transplanter. Follow the chart below.

- 42" Row Spacing - All Wide Plant Boxes
- 41" to 36" Row Spacing - Narrow Plant Boxes Inside
- 35" to 24" Row Spacing - One Wide Inside & Two Wide Outside
- 23" to 21" Row Spacing - One Narrow Inside & Two Wide Outside
- Less than 21" Row Spacing - Wide Outside Plant Boxes Only



1. Remove the long bolt between the uprights by the pocket chain. Do not lose the spacer between the uprights. Remove the outside cotter key in each axle.



2. Install the slotted mounting plates on both sides of the planter using the long bolt just removed. Do not tighten until the plant stand is fully assembled.



3. Slide plant stand onto the packing wheel axle and insert cotter key. Bend cotter key ends to keep in place.

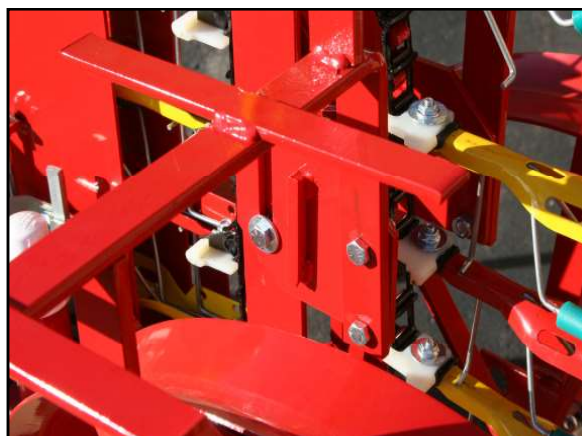

4. Use two 3/8 x 1" hex head bolts and two 3/8" nuts to attach plant stand frame to the slotted mounting bracket.



5. Attach the width adjustment plate with either the inside or outside hole depending on if you are using the wide (standard) plant boxes or the narrow with 3/8 x 1" hex head bolt and nut.

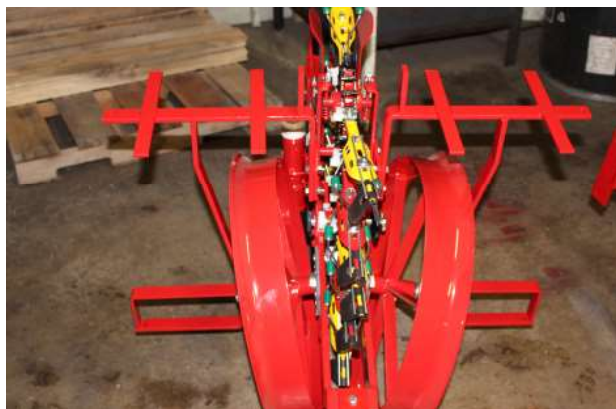

6. Install the plant boxes. These can be adjusted forward or backward for operator comfort.



Assembling the L-Shaped Seat Braces



1. Assemble the L-shaped seat brace by the chain guard. The sea brace mounts on the inside of the frame. The U-bolt mounts from the outside of the transplanter frame under the chain guard. Secure with 1/2" washers and 1/2" hex nuts over each threaded end.



2. The second L-shaped seat brace gets attached on the outside of the transplanter opposite the chain guard. The seat brace mounts on the outside of the frame with the U-bolt coming from the inside of the frame going outside through the seat brace. Secure with 1/2" washers and 1/2" hex nuts over each threaded end.



Mounting your Fiberglass or Cushion Seat

•Fiberglass Seats•



Fiberglass Seat - Turn your fiberglass seat over and remove any covers over the threaded studs. Take your green fiberglass seat bracket and mount it to the bottom of the seat with the side with the bend towards the front of the seat. Secure with four 1/4" hex nuts. Insert the 1/2 x 1-1/2 carriage bolt through the brace and then through the L-shaped seat bracket. Secure with a 1/2" washer and hex nut.

•Cushion Seats•

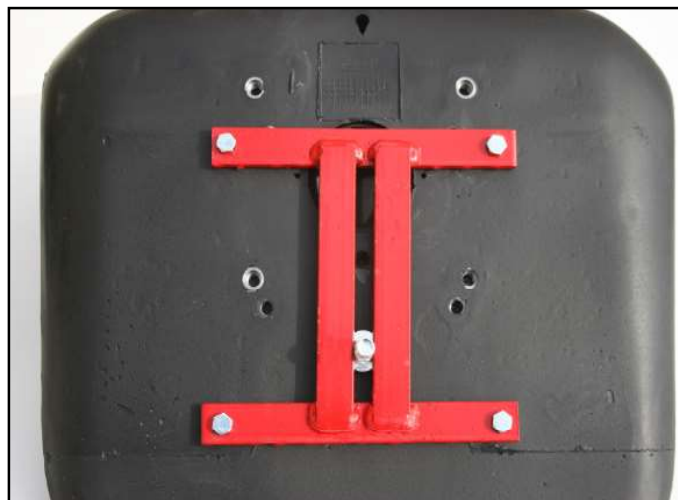

Cushion Seat - Slide the 1/2" x 1-1/2" carriage bolt through the bottom of the red seat bracket before mounting the seat bracket to the seat. After placing the carriage bolt through the seat bracket, place the seat bracket on the cushion seat. Secure with four 5/16" x 1" hex head bolts. Place the seat on the L-shaped seat bracket and secure with a 1/2" washer and hex nut.

Loose Pocket Assembly

If your Model 1000 was shipped in a crate, a pocket must be put on the empty attachment link.

The empty attachment link should be right at the top of the chain when the unit is shipped. If it is not, turn the drive wheel until the empty attachment link comes to the top.



Do NOT put #445 rubber gripper onto spring wires(#440) until pocket is assembled to attachment link.

Take the extra V-3 pocket that is wired onto unit and loosen the pocket bolt. Put pocket bolt through the attachment link. Make sure spacing bar stays under the head of the bolt. Place #375 water trip on the back of attachment link, then the 1/4" fender washer. Secure with 1/4" flange nut. After the bolt has been tightened, slide the top part of the #445 rubber gripper to the #440 wire.

Instructions for Direct Drive Clamps

The following instructions are for mounting the direct drive clamps to your Model 1000 unit. Although the pictures show the 2-1/2" clamps, use these instructions for any clamp style. They all mount the same way.



1. Insert a metal bushing from the inside of the frame. Put one of the 1/2 x 1-1/2" bolts through the bushing also from the inside.



2. Attach the clamp to the bolt in the **top** hole of the bottom set of large holes. Secure with a 1/2" hex nut.
3. If you have a Model 1000B-3 or 1000-2 follow directions below for one clamp side only. To mount safety bar on other clamp side, see page 11. In the **top** set of holes, place a 7/16 x 1-1/4" bolt through the top hole.

4. Slide the end link of the chain onto the bolt.
5. Secure the chain with a 3/8" washer and then a 7/16" hex nut. Make sure the nut is very tight.





6. Use the same instructions for the other side of the Direct Drive Wheel.

Note: The clamps may be reversed or fastened on the inside of the frame for narrow row spacings. Also, if other clamps are in the way, two lefts or two rights may be used. The lower holes on the clamps are for higher toolbars on older models or on tractors where 3-point hitch will not go low enough. Correct height of toolbar is 14" to center.

The Model 1000 unit can now be mounted to your 3-point hitch or toolbar. Following is a list of fasteners that you must use for various toolbars.

Toolbar Hardware List

- 2-1/2" or 2-1/4" Diamond toolbar - 7/8" V-bend U-bolt (2)
- 3" x 3" Flat Toolbar - 3/4" x 5" Hex bolts (4)
- 4" x 4" Flat Toolbar - 3/4" x 6" Hex bolts (4)
- 4" x 7" Toolbar - 3/4" x 9-1/2" Hex bolts (4)
- 5" x 7" Toolbar - 3/4" x 7" Hex bolts (4)
- 7" x 7" Toolbar - 3/4" x 9-1/2" (4)



Shown with clamps reversed

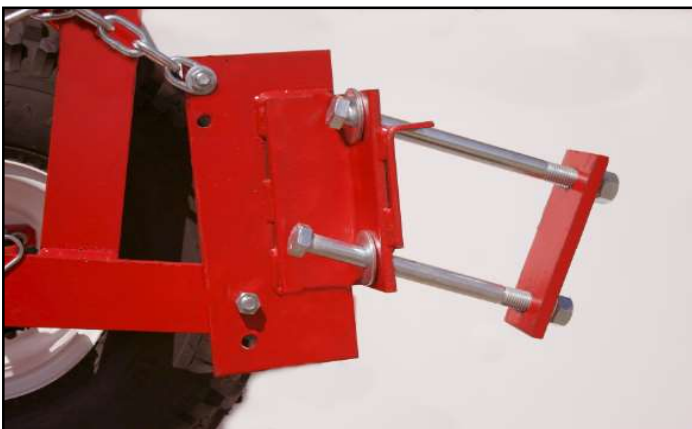

4 x 7 Toolbar Clamp. Use 2-3/4 x 9-1/2" hex bolts, 2-3/4" hex nuts and 2-3/4" washers.

Note: bent bracket on front of clamp

Model 1000B-3 Barrel Mounting & 3-Point Hitch Instructions



For B-3 Model, make sure the safety bar is properly installed!

To mount this safety bar, you must remove the 7/16 x 1-1/4" bolt from on side of the direct drive wheel.

1. Locate the special 2-1/2" stud in your bag of bolts and nuts.
2. Turn a 7/16" hex nut all the way onto the stud.
3. Put the 7/16" washer on the stud next to the nut.
4. Place the lift chain up against the washer.
5. Slide the stud through the hole on the Direct Drive frame and secure with a 7/16" hex nut.
6. Assemble another stud the same way and fasten it to the top hole of the front Direct Drive clamp.
7. Attach the red seat safety bar to the stud on your drive wheel. **The end with the hole must go on the clamp. The slotted end must go on the frame.** After the safety bar is attached, place the small clip pins through the small holes.

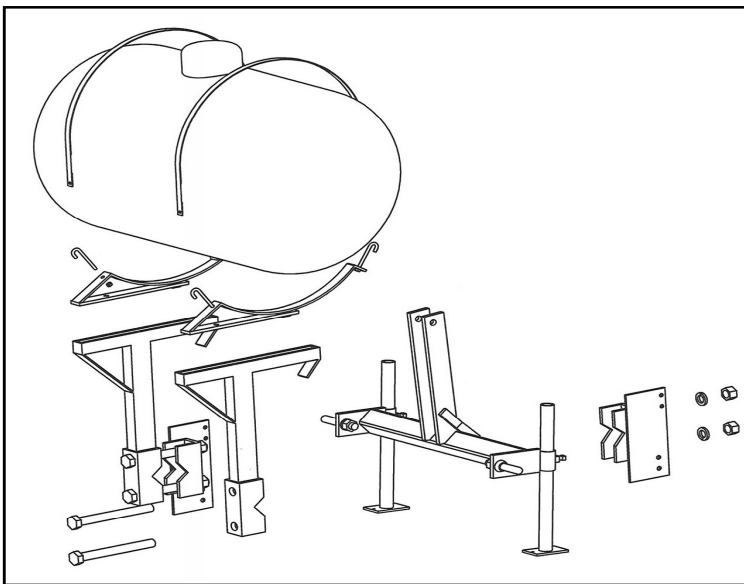

3-Point Hitch & Barrel Mounting

1. On the 3-point hitch, connect the Category I hitch pins through the holes on the outside of the hitch. Put the pins in through the outside and secure with the lock washer and hex nut included with the pin.
2. Slide the green pipe stands up through the pipes on the hitch, then tighten by turning the set screw.

Note: The following instructions will be easier with two people



3. Center the 3-point hitch toolbar with the clamps on your transplanter. Next, line up one of the barrel mounting brackets with the direct drive clamps. Secure using two 1 x 8-1/2 bolts and hex nuts. Do the same with the other barrel mounting bracket.



Side view of B-3 mountings



4. Bolt barrel hoops onto B-3 supports using 1/2 x 3" hex bolt with 1/2" lock nut. Note below: the hoops can be mounted in a forward or back position, depending on clearance that you need for the tractor fenders etc.



5. Screw in the nipple into the bottom of the tank.



6. Insert J-bolts into the four holes on the barrel hoops. It works best to thread 5/16" nut onto J-bolt before hooking up barrel hoops.



7. The 55 gallon poly tank can now be mounted on top of the barrel mountings. Use the four J-bolts and the galvanized straps to secure the barrel to the mountings.

A. Grease all fittings before the start of each day. Grease fittings are found:

1. On each packing wheel axle.
2. Upper pocket chain sprocket (Model 1000 only)
3. Direct drive tire hub (Direct Drive Units only)
4. On each nylon bushing on the pocket chain jackshaft.

B. Regulating Plant Depth

1. All operators should take care to see that the plants are placed well down in the pocket so the plant is held firmly.
2. The plant depth is regulated by the distance the root is extended out of the pocket.
3. To set the plants deeper, simply set the plant in the pocket with the roots further out than what is normally done. (See figure below)
4. If planting strawberries the axle must be raised up, allowing the transplanter unit to go deeper into the soil to cover the strawberry crowns.



V-3 Standard Plant Placement



Deeper Plant Placement

C. Pocket Chain Instructions

1. Make sure that bolts holding the upper sprocket on the pocket chain are not too tight. This will cause unnecessary friction on the unit and possible slippage on packing wheel drive transplanter. Simply loosen the wing nuts if the chain seems too tight.
2. Tighten the wing nuts equally by the top sprocket to keep the chain running level at all times.
3. If in row spacings of 20" or greater are needed, use only 6 pockets. You may remove every other pocket or leave them on. This gives the same speed or greater as a 12 pocket chain.

D. Adjusting or setting the #395R Round Point Shoe

Note: The shoe is preset at the factory for almost all situations.

Follow these instructions only if plants are leaning or in extreme wet or dry soil conditions.

1. Whenever any adjustments are made, be sure to get the shoe directly square and straight in front of the opening of the packing wheels. Make sure that the pockets will run through the middle of the shoe.
2. In loose dry soil, the shoe should be adjusted closer to the packing wheels. This can be done by adjusting the diagonal brace on the shoe.
3. In wet heavy soil, the shoe should be adjusted away from the packing wheels. Again, this can be done by adjusting the diagonal shoe brace.
4. Keep the shoe clean at all times. Do not allow dirt or trash to build up on the front or side of the shoe because this can cause too wide of a furrow that cannot be closed properly by the packing wheels. Poly covered shoes will eliminate this problem.

E. Water Valve Adjustment

1. For more water, make sure the valve is getting a full stroke by adjusting the #604 bracket on the pump rod. Make sure the valve does not over stroke. You should be able to lift the 604 rod 1/4-1/2" at the top of its stroke.
2. A broad range of adjustment can be achieved with the #603 water cam.
3. For wider spacings, the water cam may have to be raised so the water is on the plant. If the #603 is raised, be sure to raise the #604 water adjustment bracket accordingly and do not over stroke.

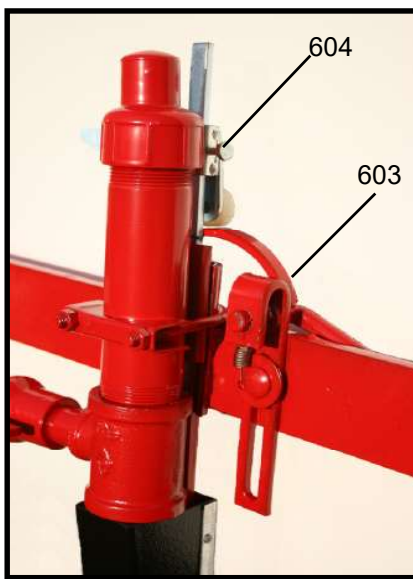

Example: At 20" row spacing, the #603 water cam should be adjusted nearly all the way up the slot. The #604 water adjustment must also be adjusted accordingly so a 1/2" remains on the 604 stroke.

4. Tilting the #603 water cam back towards the water trips on the pockets will create a longer stroke of water or more water before and after the plant.
5. Always empty the water out of the valve after quitting for the day. **Water freezing inside the valve will destroy the #610 and #612 balls inside the valve.**

F. Direct Drive Float Wheel Operation

1. Use only 4 to 5 pounds of air pressure in the Direct Drive Wheel during operation.



Wrong
Toolbar too high



Correct



Wrong
Toolbar too low

2. It is very important when starting to transplant, that the lift chains on the side of the Direct Drive Wheel are loose. See above "Correct" picture.
3. When lowering the transplanting unit into the ground, be sure that the frame members on the Direct Drive Wheel run parallel as is shown in the center picture. This is adjusted by the height of the hitch or toolbar (a pair of gauge wheels will eliminate adjustment of toolbar height).
4. Running the frame parallel will keep the lift chains loose allowing for proper floatation in the Direct Drive Wheel.
5. Running the frame members parallel and level will allow the packing wheels to run in the proper packing position.
6. Running the toolbar too low will tighten the back chains and cause the packing wheels to run too light and not pack the soil properly.
7. Running the toolbar too high will tighten the front lift chains and cause the Direct Drive Wheel to not run on the ground, especially through low spots.

Trouble Shooting

Important - Before attempting any of the following, make sure that the unit is running level or parallel to the ground. Do not run the front hitch or toolbar too far down or up. On all Model 1000 series units, make sure that the chains are loose on both sides of the arch bracket over the drive wheel. For all transplanter, make sure the soil is worked deep enough.

Problem

Solution

Packing wheels not packing properly

- A. Lengthen third arm on tractor to get float in hitch
- B. Hitch is too far down and needs to be lifted (lift chains are not loose)
- C. Clean off sides of shoe
- D. Work soil deeper
- E. Add weight to back of unit
- F. Poly shoes will eliminate soil building up on the outsides

Water leaks from top of water valve

- A. Check to see if the rubber nipple inside the top of the valve is in place and rounded.
- B. #610 ball inside the valve has collapsed and needs to be replaced.

Water leaks from bottom of water valve

- A. Rubber ball #612 on pin is broke and needs to be replaced
- B. The nylon nut on the bottom is broken and needs to be replaced

Water not uniform

- A. Make sure all the water trips on the pockets are in good shape and at even distances from the attachment link.
- B. Check to see that all springs on the water valve are in good working order.
- C. Water valve has dirt or residue build up that needs to be cleaned out

Water misses plants

•See water valve instructions on Page13.

Plants falling out of pocket

- A. Inspect the rubber grippers to make sure that they are not all stretched out.
- B. Tighten the L-bolts on the side of the guides.
- C. #482 pocket extensions may be needed if planting cell-type plants.
- D. Check bottom of guides to insure that the pocket is not releasing the plant too soon.

Plants on top of soil

- A. Cut back on water because the plants are floating up out of the shoe.
- B. Plants need to be pulled further out of the pocket to put them deeper.
- C. Too much loose soil is getting inside the shoe before the packing wheels can pack. Move shoe closer to packing wheels.
- D. A gap might be occurring by having the hitch too low causing the packing wheels to be up in the air or not being able to put enough pressure on the soil.
- E. Ground not worked deep enough causing the shoe to not go deep enough into the soil.

Plants leaning

- A. Need to put plant further in the pocket to keep it from hitting the bottom of the furrow.
- B. Possibility of needing a deeper shoe.
- C. May need #482 extensions to help support the cell of a plant coming from a tray.
- D. See Operating Instructions on Page 13 about adjusting the shoe.

Safety Precautions

1. Make sure tractor is stopped and in neutral with the transplanter lowered to the ground before getting on and off the unit.
2. No operator is allowed to be on the unit as it is raised and lowered.
3. No operator is allowed on the transplanter as it is transported to or from the field.
4. All operators must be seated before movement begins and remain seated until the transplanter is completely stopped.
5. Never leave the transplanter in the raised position.
6. Keep all shields and guards in place when operating the transplanter.
7. Never attempt repairs or maintenance while the transplanter is in motion.
8. Never put the tractor in reverse while the transplanter is on the ground.
9. Follow all safety instructions supplied by the tractor manufacturer to which the transplanter is mounted.

MACHINE IMPROVEMENTS

MECHANICAL TRANSPLANTER CO. IS ALWAYS STRIVING TO MAKE IMPROVEMENTS ON THEIR LINE OF EQUIPMENT. MECHANICAL TRANSPLANTER CO. RESERVES THE RIGHT TO MAKE IMPROVEMENTS AND CHANGES AT ANY TIME WITHOUT INCURRING OBLIGATIONS TO MAKE SUCH CHANGES OR ADDITIONS TO EQUIPMENT PREVIOUSLY SOLD.

Limited Warranty

Mechanical Transplanter Company warrants each item of new equipment manufactured by Mechanical to be free from defects in material and workmanship under normal use and service.

The obligation of Mechanical Transplanter Company under this LIMITED WARRANTY is limited to repairing or replacing as Mechanical may elect, and any parts that prove, in Mechanical's judgment, to be defective in material and workmanship within the first season's use or 45 consecutive days after initially placing equipment in operation, whichever occurs first. Any outside work or alterations without Mechanical's written approval will render the LIMITED WARRANTY void.

Mechanical's obligation specifically excludes any liability for consequential damages, such as loss of profits, delays, expenses, damage to goods or property used in connection with or processed in or by the product sold, or damage to the product sold from whatsoever cause, whether or not such loss is due to negligence of selling dealer of Mechanical Transplanter Company.

This limited warranty shall not apply to any item or machine which shall have been operated in a manner not recommended by the Company nor which shall have been repaired, altered, misused, damaged in an accident, neglected, tampered with or used in any way which in the Company's opinion adversely affects its performance and results.

No person is authorized to give any other warranties or to assume any other liability on behalf of Mechanical Transplanter Company, unless made in writing by Mechanical.

This limited warranty covers repair or replacement of Mechanical Transplanter Co. equipment only and does not cover crop loss, downtime, labor, damage to other equipment, etc.

This limited warranty does not apply to exterior finishes, tires, chain links, bearings, or any other items sold by Mechanical Transplanter Co., but warranted by the original manufacturer except to the extent of their individual manufacturer's warranty.

THIS LIMITED WARRANTY IS IN LIEU OF ALL OTHER WARRANTIES, EXPRESSED OR IMPLIED. WARRANTIES OF MERCHANTABILITY AND FITNESS FOR PARTICULAR PURPOSE ARE EXCLUDED, AS ARE ALL OTHER REPRESENTATIONS TO THE USER-PURCHASER, AND ALL OTHER OBLIGATIONS OR LIABILITIES, INCLUDING LIABILITY FOR INCIDENTAL AND CONSEQUENTIAL DAMAGES, ON THE PART OF MECHANICAL OR THE SELLER.

Mechanical Transplanter Co.

Model 1000 and 1000B-3

Operators Manual



Mechanical Transplanter Co., LLC
1150 Central Avenue • Holland, MI 49423-5230
Phone: 616-396-8738 • Fax: 616-396-3619
website: www.mechanicaltransplanter.com
e-mail: mtc@mechanicaltransplanter.com

Spacing Charts and Information

| SPACING CHART FOR DIRECT DRIVE UNIT W/ 12 POCKET CHAIN | | | | | | |
|---|---------------------------------|-------------------------------------|-----------------------|-----------------------|-------------------|-----------------|
| Sprocket on OUT-SIDE of Jackshaft | Sprocket on INSIDE of Jackshaft | Number of Teeth on Sprocket on Unit | | | | |
| | | 7 | 8 | 9 | 10 | 11 |
| 7 | 11 | 6" 15.2cm | 6-1/2" - 7" 17.8cm | 7-1/2" - 8" 20.3cm | 8-1/2" 21.6cm | 9" 22.8cm |
| 7 | 7 | 9" 22.8cm | 10-1/2" 26.7cm | 13" 33cm | 15" 38.1cm | 16" 40.6cm |
| 8 | 7 | 10-1/2" 26.7cm | 12-1/2" 31.7cm | 14" 35.5cm | 15" 38.1cm | 16" 40.6cm |
| 9 | 7 | 12" 30.5cm | 13-1/2" 34.3cm | 15" 38.1cm | 17" 43.2cm | 18-1/2" 47cm |
| 10 | 7 | 13" 33cm | 14" 35.5cm | 15-1/2" 39.4cm | 17-1/2" 44.5cm | 20-1/2" 52cm |
| 11 | 7 | 15" 38.1cm | 18" 45.7cm | | | |

Double any of the above spacings by using every other pocket (6 pocket).
Make sure HITCH and UNIT are level or parallel to the ground when planting.

Use for Model 1000

| DISC SPACING CHART FOR MODELS W/ DIRECT DRIVE | | | | | | | |
|--|---------------------------------|-------------------------------|-------------------------------------|--------|--------|--------|--------|
| Sprocket on OUTSIDE of Jackshaft | Sprocket on INSIDE of Jackshaft | Number of Pockets on the Disc | Number of Teeth on Sprocket by Disc | | | | |
| | | | 7 | 8 | 9 | 10 | 11 |
| 7 | 7 | 24 | | 2" | 2-1/4" | 2-1/2" | 2-3/4" |
| | | 16 | 3" | 3-1/4" | 3-1/2" | 4" | 4-1/2" |
| | | 12 | | 4-3/4" | 5-1/4" | 5-3/4" | 6-1/4" |
| 8 | 7 | 24 | | 2-1/2" | 3" | 3-1/4" | 3-1/2" |
| | | 16 | 3-1/2" | 3-3/4" | 4-1/4" | 4-1/2" | 5-1/4" |
| | | 12 | | 6" | 6-1/4" | 6-3/4" | 7" |
| 9 | 7 | 24 | 2-1/2" | 2-3/4" | 3-1/4" | 3-1/2" | 4" |
| | | 16 | 3-3/4" | 4-1/4" | 4-1/2" | 5" | 5-1/2" |
| | | 12 | 4-1/2" | 6-1/4" | 6-1/2" | 7-1/4" | 8" |
| 10 | 7 | 24 | 2-1/2" | 3" | 3-1/2" | 3-3/4" | 4-1/2" |
| | | 16 | 3-3/4" | 4-1/2" | 5-1/4" | | |
| | | 12 | 5-1/4" | 6" | 7" | 7-1/2" | 8-1/2" |
| 11 | 7 | 24 | 2-1/2" | 3" | 3-1/2" | 4-1/4" | 4-3/4" |
| | | 16 | 4" | 5" | 6" | | |
| | | 12 | 5-1/2" | 6-1/2" | 7-1/2" | 9" | 10" |

Use for Model 1000 with disc mounted pockets

Assembly Instructions

For Model 1000 Series Transplanters

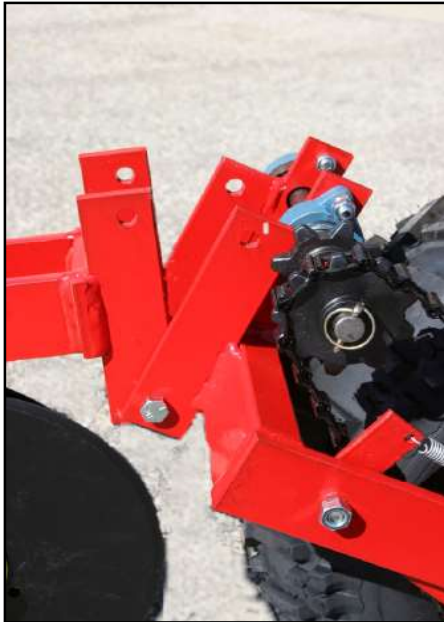

1. Bolt on the Direct Drive Float Wheel using the four 1/2 x 1-1/2 " bolts. Secure using the 1/2" hex nuts.



2. Remove the following parts from the direct drive wheel jackshaft: Clip pin, drive chain coming from the wheel, outside sprocket on jackshaft, and pipe spacer. Then remove the extra top hex nut located on the flange bearing.



3. Install the inside chain guard of the unit. Fasten front short tab to the top bolt on flange bearing from #2 photo with hex nut. The long tab attaches to the empty hole on the transplanter frame by the packing wheels. The guard must fit between the shoe brace and the guide adjustment bolt. Use the 3/8 x 1" bolt and a 3/8" hex nut to secure.

4. Select the proper sprocket arrangement for the spacing needed between plants. Look on page 2 or the chart on the side of your transplanter for the correct arrangement. For spacings using 11 tooth sprockets, extra chain links may be needed to lengthen the drive chain. These links are wired to the lift chain by the drive wheel. After finding the correct sprockets, run the long drive chain from the sprocket on the pocket chain shaft to the inside sprocket on the jackshaft of the direct drive wheel. The chain must go over the idler sprocket on the shoe brace and under the chain tightener sprocket as shown in the photo below.



5. Slide the red pipe spacer back onto the jackshaft. Insert the roll pin back into the second hole from the outside of the jackshaft. Slide the outside sprocket over the roll pin. Slide the drive chain coming from the drive wheel over the outside jackshaft sprocket. You may have to use your hand to push the chain tightener up to create enough slack in the chain. Insert the clip pin into the outside hole of the jackshaft.



6. Slide the outside chain guard onto the two pins and secure with clip pins.

Installation of Plant Stands

It is very important to know what row width will be used before installing the plant stands on multi-row transplanter. Follow the chart below.

- 42" Row Spacing - All Wide Plant Boxes
- 41" to 36" Row Spacing - Narrow Plant Boxes Inside
- 35" to 24" Row Spacing - One Wide Inside & Two Wide Outside
- 23" to 21" Row Spacing - One Narrow Inside & Two Wide Outside
- Less than 21" Row Spacing - Wide Outside Plant Boxes Only



1. Remove the long bolt between the uprights by the pocket chain. Do not lose the spacer between the uprights. Remove the outside cotter key in each axle.



2. Install the slotted mounting plates on both sides of the planter using the long bolt just removed. Do not tighten until the plant stand is fully assembled.



3. Slide plant stand onto the packing wheel axle and insert cotter key. Bend cotter key ends to keep in place.

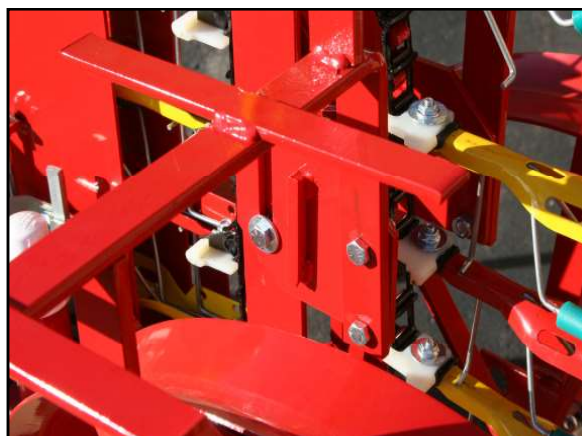

4. Use two 3/8 x 1" hex head bolts and two 3/8" nuts to attach plant stand frame to the slotted mounting bracket.



5. Attach the width adjustment plate with either the inside or outside hole depending on if you are using the wide (standard) plant boxes or the narrow with 3/8 x 1" hex head bolt and nut.

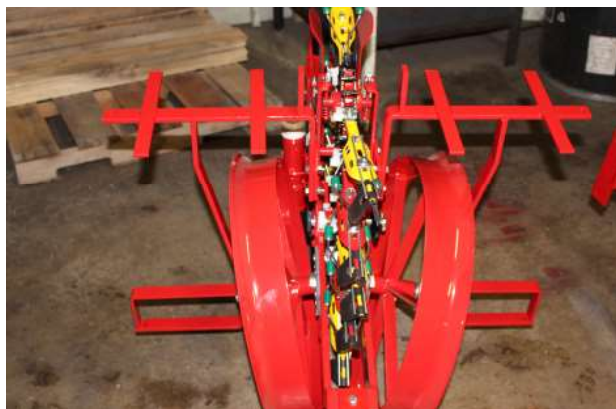

6. Install the plant boxes. These can be adjusted forward or backward for operator comfort.



Assembling the L-Shaped Seat Braces



1. Assemble the L-shaped seat brace by the chain guard. The sea brace mounts on the inside of the frame. The U-bolt mounts from the outside of the transplanter frame under the chain guard. Secure with 1/2" washers and 1/2" hex nuts over each threaded end.



2. The second L-shaped seat brace gets attached on the outside of the transplanter opposite the chain guard. The seat brace mounts on the outside of the frame with the U-bolt coming from the inside of the frame going outside through the seat brace. Secure with 1/2" washers and 1/2" hex nuts over each threaded end.

Mounting your Fiberglass or Cushion Seat

•Fiberglass Seats•



Fiberglass Seat - Turn your fiberglass seat over and remove any covers over the threaded studs. Take your green fiberglass seat bracket and mount it to the bottom of the seat with the side with the bend towards the front of the seat. Secure with four 1/4" hex nuts. Insert the 1/2 x 1-1/2 carriage bolt through the brace and then through the L-shaped seat bracket. Secure with a 1/2" washer and hex nut.

•Cushion Seats•

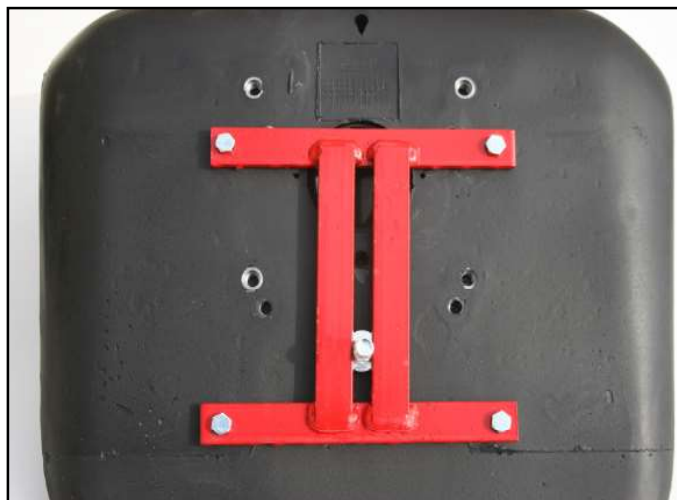

Cushion Seat - Slide the 1/2" x 1-1/2" carriage bolt through the bottom of the red seat bracket before mounting the seat bracket to the seat. After placing the carriage bolt through the seat bracket, place the seat bracket on the cushion seat. Secure with four 5/16" x 1" hex head bolts. Place the seat on the L-shaped seat bracket and secure with a 1/2" washer and hex nut.

Loose Pocket Assembly

If your Model 1000 was shipped in a crate, a pocket must be put on the empty attachment link.

The empty attachment link should be right at the top of the chain when the unit is shipped. If it is not, turn the drive wheel until the empty attachment link comes to the top.



Do NOT put #445 rubber gripper onto spring wires(#440) until pocket is assembled to attachment link.

Take the extra V-3 pocket that is wired onto unit and loosen the pocket bolt. Put pocket bolt through the attachment link. Make sure spacing bar stays under the head of the bolt. Place #375 water trip on the back of attachment link, then the 1/4" fender washer. Secure with 1/4" flange nut. After the bolt has been tightened, slide the top part of the #445 rubber gripper to the #440 wire.

Instructions for Direct Drive Clamps

The following instructions are for mounting the direct drive clamps to your Model 1000 unit. Although the pictures show the 2-1/2" clamps, use these instructions for any clamp style. They all mount the same way.



1. Insert a metal bushing from the inside of the frame. Put one of the 1/2 x 1-1/2" bolts through the bushing also from the inside.



2. Attach the clamp to the bolt in the **top** hole of the bottom set of large holes. Secure with a 1/2" hex nut.
3. If you have a Model 1000B-3 or 1000-2 follow directions below for one clamp side only. To mount safety bar on other clamp side, see page 11. In the **top** set of holes, place a 7/16 x 1-1/4" bolt through the top hole.

4. Slide the end link of the chain onto the bolt.
5. Secure the chain with a 3/8" washer and then a 7/16" hex nut. Make sure the nut is very tight.





6. Use the same instructions for the other side of the Direct Drive Wheel.

Note: The clamps may be reversed or fastened on the inside of the frame for narrow row spacings. Also, if other clamps are in the way, two lefts or two rights may be used. The lower holes on the clamps are for higher toolbars on older models or on tractors where 3-point hitch will not go low enough. Correct height of toolbar is 14" to center.

The Model 1000 unit can now be mounted to your 3-point hitch or toolbar. Following is a list of fasteners that you must use for various toolbars.

Toolbar Hardware List

- 2-1/2" or 2-1/4" Diamond toolbar - 7/8" V-bend U-bolt (2)
- 3" x 3" Flat Toolbar - 3/4" x 5" Hex bolts (4)
- 4" x 4" Flat Toolbar - 3/4" x 6" Hex bolts (4)
- 4" x 7" Toolbar - 3/4" x 9-1/2" Hex bolts (4)
- 5" x 7" Toolbar - 3/4" x 7" Hex bolts (4)
- 7" x 7" Toolbar - 3/4" x 9-1/2" (4)



Shown with clamps reversed

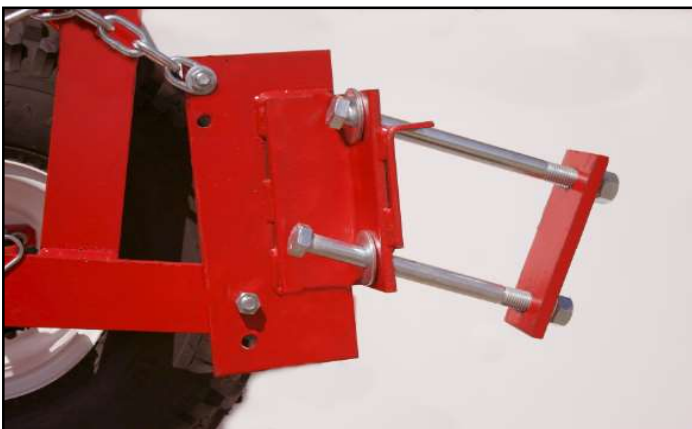

4 x 7 Toolbar Clamp. Use 2-3/4 x 9-1/2" hex bolts, 2-3/4" hex nuts and 2-3/4" washers.

Note: bent bracket on front of clamp

Model 1000B-3 Barrel Mounting & 3-Point Hitch Instructions



For B-3 Model, make sure the safety bar is properly installed!

To mount this safety bar, you must remove the 7/16 x 1-1/4" bolt from on side of the direct drive wheel.

1. Locate the special 2-1/2" stud in your bag of bolts and nuts.
2. Turn a 7/16" hex nut all the way onto the stud.
3. Put the 7/16" washer on the stud next to the nut.
4. Place the lift chain up against the washer.
5. Slide the stud through the hole on the Direct Drive frame and secure with a 7/16" hex nut.
6. Assemble another stud the same way and fasten it to the top hole of the front Direct Drive clamp.
7. Attach the red seat safety bar to the stud on your drive wheel. **The end with the hole must go on the clamp. The slotted end must go on the frame.** After the safety bar is attached, place the small clip pins through the small holes.

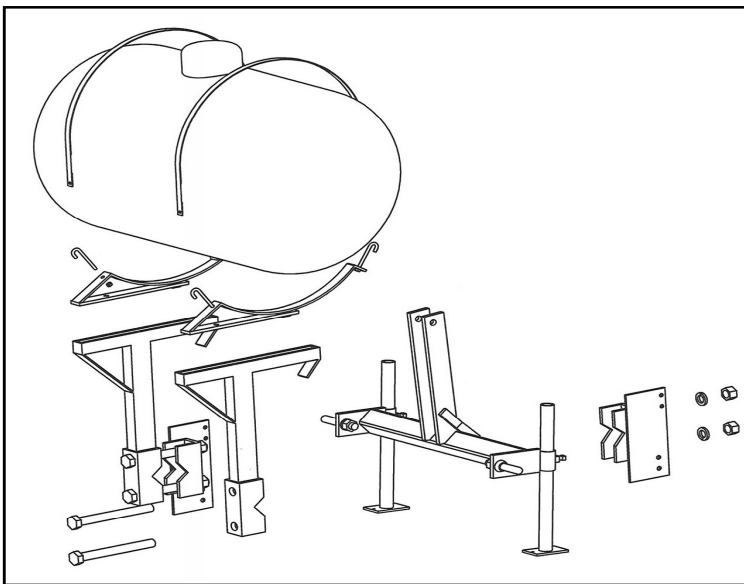

3-Point Hitch & Barrel Mounting

1. On the 3-point hitch, connect the Category I hitch pins through the holes on the outside of the hitch. Put the pins in through the outside and secure with the lock washer and hex nut included with the pin.
2. Slide the green pipe stands up through the pipes on the hitch, then tighten by turning the set screw.

Note: The following instructions will be easier with two people



3. Center the 3-point hitch toolbar with the clamps on your transplanter. Next, line up one of the barrel mounting brackets with the direct drive clamps. Secure using two 1 x 8-1/2 bolts and hex nuts. Do the same with the other barrel mounting bracket.



Side view of B-3 mountings



4. Bolt barrel hoops onto B-3 supports using 1/2 x 3" hex bolt with 1/2" lock nut. Note below: the hoops can be mounted in a forward or back position, depending on clearance that you need for the tractor fenders etc.



5. Screw in the nipple into the bottom of the tank.



6. Insert J-bolts into the four holes on the barrel hoops. It works best to thread 5/16" nut onto J-bolt before hooking up barrel hoops.



7. The 55 gallon poly tank can now be mounted on top of the barrel mountings. Use the four J-bolts and the galvanized straps to secure the barrel to the mountings.

A. Grease all fittings before the start of each day. Grease fittings are found:

1. On each packing wheel axle.
2. Upper pocket chain sprocket (Model 1000 only)
3. Direct drive tire hub (Direct Drive Units only)
4. On each nylon bushing on the pocket chain jackshaft.

B. Regulating Plant Depth

1. All operators should take care to see that the plants are placed well down in the pocket so the plant is held firmly.
2. The plant depth is regulated by the distance the root is extended out of the pocket.
3. To set the plants deeper, simply set the plant in the pocket with the roots further out than what is normally done. (See figure below)
4. If planting strawberries the axle must be raised up, allowing the transplanter unit to go deeper into the soil to cover the strawberry crowns.



V-3 Standard Plant Placement



Deeper Plant Placement

C. Pocket Chain Instructions

1. Make sure that bolts holding the upper sprocket on the pocket chain are not too tight. This will cause unnecessary friction on the unit and possible slippage on packing wheel drive transplanter. Simply loosen the wing nuts if the chain seems too tight.
2. Tighten the wing nuts equally by the top sprocket to keep the chain running level at all times.
3. If in row spacings of 20" or greater are needed, use only 6 pockets. You may remove every other pocket or leave them on. This gives the same speed or greater as a 12 pocket chain.

D. Adjusting or setting the #395R Round Point Shoe

Note: The shoe is preset at the factory for almost all situations.

Follow these instructions only if plants are leaning or in extreme wet or dry soil conditions.

1. Whenever any adjustments are made, be sure to get the shoe directly square and straight in front of the opening of the packing wheels. Make sure that the pockets will run through the middle of the shoe.
2. In loose dry soil, the shoe should be adjusted closer to the packing wheels. This can be done by adjusting the diagonal brace on the shoe.
3. In wet heavy soil, the shoe should be adjusted away from the packing wheels. Again, this can be done by adjusting the diagonal shoe brace.
4. Keep the shoe clean at all times. Do not allow dirt or trash to build up on the front or side of the shoe because this can cause too wide of a furrow that cannot be closed properly by the packing wheels. Poly covered shoes will eliminate this problem.

E. Water Valve Adjustment

1. For more water, make sure the valve is getting a full stroke by adjusting the #604 bracket on the pump rod. Make sure the valve does not over stroke. You should be able to lift the 604 rod 1/4-1/2" at the top of its stroke.
2. A broad range of adjustment can be achieved with the #603 water cam.
3. For wider spacings, the water cam may have to be raised so the water is on the plant. If the #603 is raised, be sure to raise the #604 water adjustment bracket accordingly and do not over stroke.

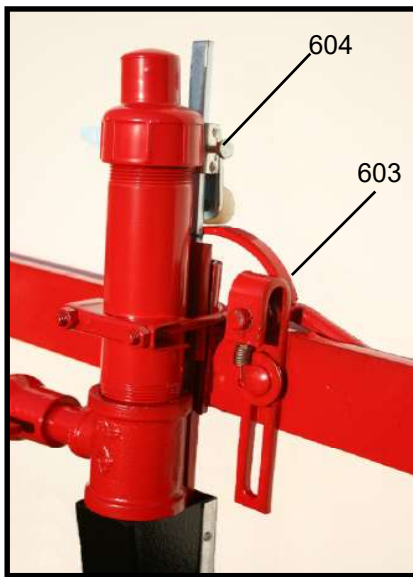

Example: At 20" row spacing, the #603 water cam should be adjusted nearly all the way up the slot. The #604 water adjustment must also be adjusted accordingly so a 1/2" remains on the 604 stroke.

4. Tilting the #603 water cam back towards the water trips on the pockets will create a longer stroke of water or more water before and after the plant.
5. Always empty the water out of the valve after quitting for the day. **Water freezing inside the valve will destroy the #610 and #612 balls inside the valve.**

F. Direct Drive Float Wheel Operation

1. Use only 4 to 5 pounds of air pressure in the Direct Drive Wheel during operation.



Wrong
Toolbar too high



Correct



Wrong
Toolbar too low

2. It is very important when starting to transplant, that the lift chains on the side of the Direct Drive Wheel are loose. See above "Correct" picture.
3. When lowering the transplanting unit into the ground, be sure that the frame members on the Direct Drive Wheel run parallel as is shown in the center picture. This is adjusted by the height of the hitch or toolbar (a pair of gauge wheels will eliminate adjustment of toolbar height).
4. Running the frame parallel will keep the lift chains loose allowing for proper floatation in the Direct Drive Wheel.
5. Running the frame members parallel and level will allow the packing wheels to run in the proper packing position.
6. Running the toolbar too low will tighten the back chains and cause the packing wheels to run too light and not pack the soil properly.
7. Running the toolbar too high will tighten the front lift chains and cause the Direct Drive Wheel to not run on the ground, especially through low spots.

Trouble Shooting

Important - Before attempting any of the following, make sure that the unit is running level or parallel to the ground. Do not run the front hitch or toolbar too far down or up. On all Model 1000 series units, make sure that the chains are loose on both sides of the arch bracket over the drive wheel. For all transplanter, make sure the soil is worked deep enough.

Problem

Solution

Packing wheels not packing properly

- A. Lengthen third arm on tractor to get float in hitch
- B. Hitch is too far down and needs to be lifted (lift chains are not loose)
- C. Clean off sides of shoe
- D. Work soil deeper
- E. Add weight to back of unit
- F. Poly shoes will eliminate soil building up on the outsides

Water leaks from top of water valve

- A. Check to see if the rubber nipple inside the top of the valve is in place and rounded.
- B. #610 ball inside the valve has collapsed and needs to be replaced.

Water leaks from bottom of water valve

- A. Rubber ball #612 on pin is broke and needs to be replaced
- B. The nylon nut on the bottom is broken and needs to be replaced

Water not uniform

- A. Make sure all the water trips on the pockets are in good shape and at even distances from the attachment link.
- B. Check to see that all springs on the water valve are in good working order.
- C. Water valve has dirt or residue build up that needs to be cleaned out

Water misses plants

•See water valve instructions on Page13.

Plants falling out of pocket

- A. Inspect the rubber grippers to make sure that they are not all stretched out.
- B. Tighten the L-bolts on the side of the guides.
- C. #482 pocket extensions may be needed if planting cell-type plants.
- D. Check bottom of guides to insure that the pocket is not releasing the plant too soon.

Plants on top of soil

- A. Cut back on water because the plants are floating up out of the shoe.
- B. Plants need to be pulled further out of the pocket to put them deeper.
- C. Too much loose soil is getting inside the shoe before the packing wheels can pack. Move shoe closer to packing wheels.
- D. A gap might be occurring by having the hitch too low causing the packing wheels to be up in the air or not being able to put enough pressure on the soil.
- E. Ground not worked deep enough causing the shoe to not go deep enough into the soil.

Plants leaning

- A. Need to put plant further in the pocket to keep it from hitting the bottom of the furrow.
- B. Possibility of needing a deeper shoe.
- C. May need #482 extensions to help support the cell of a plant coming from a tray.
- D. See Operating Instructions on Page 13 about adjusting the shoe.

Safety Precautions

1. Make sure tractor is stopped and in neutral with the transplanter lowered to the ground before getting on and off the unit.
2. No operator is allowed to be on the unit as it is raised and lowered.
3. No operator is allowed on the transplanter as it is transported to or from the field.
4. All operators must be seated before movement begins and remain seated until the transplanter is completely stopped.
5. Never leave the transplanter in the raised position.
6. Keep all shields and guards in place when operating the transplanter.
7. Never attempt repairs or maintenance while the transplanter is in motion.
8. Never put the tractor in reverse while the transplanter is on the ground.
9. Follow all safety instructions supplied by the tractor manufacturer to which the transplanter is mounted.

MACHINE IMPROVEMENTS

MECHANICAL TRANSPLANTER CO. IS ALWAYS STRIVING TO MAKE IMPROVEMENTS ON THEIR LINE OF EQUIPMENT. MECHANICAL TRANSPLANTER CO. RESERVES THE RIGHT TO MAKE IMPROVEMENTS AND CHANGES AT ANY TIME WITHOUT INCURRING OBLIGATIONS TO MAKE SUCH CHANGES OR ADDITIONS TO EQUIPMENT PREVIOUSLY SOLD.

Limited Warranty

Mechanical Transplanter Company warrants each item of new equipment manufactured by Mechanical to be free from defects in material and workmanship under normal use and service.

The obligation of Mechanical Transplanter Company under this LIMITED WARRANTY is limited to repairing or replacing as Mechanical may elect, and any parts that prove, in Mechanical's judgment, to be defective in material and workmanship within the first season's use or 45 consecutive days after initially placing equipment in operation, whichever occurs first. Any outside work or alterations without Mechanical's written approval will render the LIMITED WARRANTY void.

Mechanical's obligation specifically excludes any liability for consequential damages, such as loss of profits, delays, expenses, damage to goods or property used in connection with or processed in or by the product sold, or damage to the product sold from whatsoever cause, whether or not such loss is due to negligence of selling dealer of Mechanical Transplanter Company.

This limited warranty shall not apply to any item or machine which shall have been operated in a manner not recommended by the Company nor which shall have been repaired, altered, misused, damaged in an accident, neglected, tampered with or used in any way which in the Company's opinion adversely affects its performance and results.

No person is authorized to give any other warranties or to assume any other liability on behalf of Mechanical Transplanter Company, unless made in writing by Mechanical.

This limited warranty covers repair or replacement of Mechanical Transplanter Co. equipment only and does not cover crop loss, downtime, labor, damage to other equipment, etc.

This limited warranty does not apply to exterior finishes, tires, chain links, bearings, or any other items sold by Mechanical Transplanter Co., but warranted by the original manufacturer except to the extent of their individual manufacturer's warranty.

THIS LIMITED WARRANTY IS IN LIEU OF ALL OTHER WARRANTIES, EXPRESSED OR IMPLIED. WARRANTIES OF MERCHANTABILITY AND FITNESS FOR PARTICULAR PURPOSE ARE EXCLUDED, AS ARE ALL OTHER REPRESENTATIONS TO THE USER-PURCHASER, AND ALL OTHER OBLIGATIONS OR LIABILITIES, INCLUDING LIABILITY FOR INCIDENTAL AND CONSEQUENTIAL DAMAGES, ON THE PART OF MECHANICAL OR THE SELLER.

Mechanical Transplanter Co.

Model 1000 and 1000B-3

Operators Manual



Mechanical Transplanter Co., LLC
1150 Central Avenue • Holland, MI 49423-5230
Phone: 616-396-8738 • Fax: 616-396-3619
website: www.mechanicaltransplanter.com
e-mail: mtc@mechanicaltransplanter.com

Spacing Charts and Information

| SPACING CHART FOR DIRECT DRIVE UNIT W/ 12 POCKET CHAIN | | | | | | |
|---|---------------------------------|-------------------------------------|-----------------------|-----------------------|-------------------|-----------------|
| Sprocket on OUT-SIDE of Jackshaft | Sprocket on INSIDE of Jackshaft | Number of Teeth on Sprocket on Unit | | | | |
| | | 7 | 8 | 9 | 10 | 11 |
| 7 | 11 | 6" 15.2cm | 6-1/2" - 7" 17.8cm | 7-1/2" - 8" 20.3cm | 8-1/2" 21.6cm | 9" 22.8cm |
| 7 | 7 | 9" 22.8cm | 10-1/2" 26.7cm | 13" 33cm | 15" 38.1cm | 16" 40.6cm |
| 8 | 7 | 10-1/2" 26.7cm | 12-1/2" 31.7cm | 14" 35.5cm | 15" 38.1cm | 16" 40.6cm |
| 9 | 7 | 12" 30.5cm | 13-1/2" 34.3cm | 15" 38.1cm | 17" 43.2cm | 18-1/2" 47cm |
| 10 | 7 | 13" 33cm | 14" 35.5cm | 15-1/2" 39.4cm | 17-1/2" 44.5cm | 20-1/2" 52cm |
| 11 | 7 | 15" 38.1cm | 18" 45.7cm | | | |

Double any of the above spacings by using every other pocket (6 pocket).
Make sure HITCH and UNIT are level or parallel to the ground when planting.

Use for Model 1000

| DISC SPACING CHART FOR MODELS W/ DIRECT DRIVE | | | | | | | |
|--|---------------------------------|-------------------------------|-------------------------------------|--------|--------|--------|--------|
| Sprocket on OUTSIDE of Jackshaft | Sprocket on INSIDE of Jackshaft | Number of Pockets on the Disc | Number of Teeth on Sprocket by Disc | | | | |
| | | | 7 | 8 | 9 | 10 | 11 |
| 7 | 7 | 24 | | 2" | 2-1/4" | 2-1/2" | 2-3/4" |
| | | 16 | 3" | 3-1/4" | 3-1/2" | 4" | 4-1/2" |
| | | 12 | | 4-3/4" | 5-1/4" | 5-3/4" | 6-1/4" |
| 8 | 7 | 24 | | 2-1/2" | 3" | 3-1/4" | 3-1/2" |
| | | 16 | 3-1/2" | 3-3/4" | 4-1/4" | 4-1/2" | 5-1/4" |
| | | 12 | | 6" | 6-1/4" | 6-3/4" | 7" |
| 9 | 7 | 24 | 2-1/2" | 2-3/4" | 3-1/4" | 3-1/2" | 4" |
| | | 16 | 3-3/4" | 4-1/4" | 4-1/2" | 5" | 5-1/2" |
| | | 12 | 4-1/2" | 6-1/4" | 6-1/2" | 7-1/4" | 8" |
| 10 | 7 | 24 | 2-1/2" | 3" | 3-1/2" | 3-3/4" | 4-1/2" |
| | | 16 | 3-3/4" | 4-1/2" | 5-1/4" | | |
| | | 12 | 5-1/4" | 6" | 7" | 7-1/2" | 8-1/2" |
| 11 | 7 | 24 | 2-1/2" | 3" | 3-1/2" | 4-1/4" | 4-3/4" |
| | | 16 | 4" | 5" | 6" | | |
| | | 12 | 5-1/2" | 6-1/2" | 7-1/2" | 9" | 10" |

Use for Model 1000 with disc mounted pockets

Assembly Instructions

For Model 1000 Series Transplanters

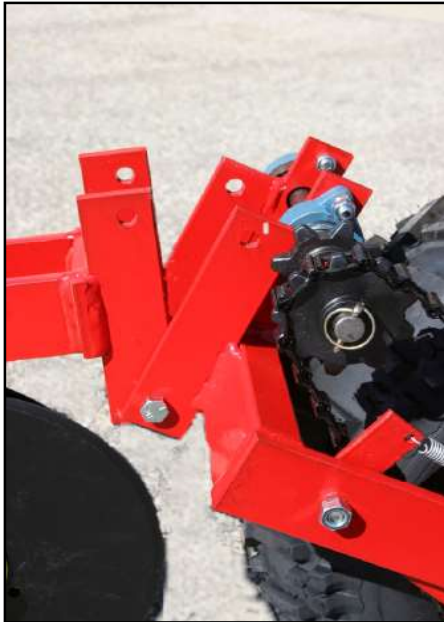

1. Bolt on the Direct Drive Float Wheel using the four 1/2 x 1-1/2 " bolts. Secure using the 1/2" hex nuts.



2. Remove the following parts from the direct drive wheel jackshaft: Clip pin, drive chain coming from the wheel, outside sprocket on jackshaft, and pipe spacer. Then remove the extra top hex nut located on the flange bearing.



3. Install the inside chain guard of the unit. Fasten front short tab to the top bolt on flange bearing from #2 photo with hex nut. The long tab attaches to the empty hole on the transplanter frame by the packing wheels. The guard must fit between the shoe brace and the guide adjustment bolt. Use the 3/8 x 1" bolt and a 3/8" hex nut to secure.

4. Select the proper sprocket arrangement for the spacing needed between plants. Look on page 2 or the chart on the side of your transplanter for the correct arrangement. For spacings using 11 tooth sprockets, extra chain links may be needed to lengthen the drive chain. These links are wired to the lift chain by the drive wheel. After finding the correct sprockets, run the long drive chain from the sprocket on the pocket chain shaft to the inside sprocket on the jackshaft of the direct drive wheel. The chain must go over the idler sprocket on the shoe brace and under the chain tightener sprocket as shown in the photo below.



5. Slide the red pipe spacer back onto the jackshaft. Insert the roll pin back into the second hole from the outside of the jackshaft. Slide the outside sprocket over the roll pin. Slide the drive chain coming from the drive wheel over the outside jackshaft sprocket. You may have to use your hand to push the chain tightener up to create enough slack in the chain. Insert the clip pin into the outside hole of the jackshaft.



6. Slide the outside chain guard onto the two pins and secure with clip pins.

Installation of Plant Stands

It is very important to know what row width will be used before installing the plant stands on multi-row transplanter. Follow the chart below.

- 42" Row Spacing - All Wide Plant Boxes
- 41" to 36" Row Spacing - Narrow Plant Boxes Inside
- 35" to 24" Row Spacing - One Wide Inside & Two Wide Outside
- 23" to 21" Row Spacing - One Narrow Inside & Two Wide Outside
- Less than 21" Row Spacing - Wide Outside Plant Boxes Only



1. Remove the long bolt between the uprights by the pocket chain. Do not lose the spacer between the uprights. Remove the outside cotter key in each axle.



2. Install the slotted mounting plates on both sides of the planter using the long bolt just removed. Do not tighten until the plant stand is fully assembled.



3. Slide plant stand onto the packing wheel axle and insert cotter key. Bend cotter key ends to keep in place.

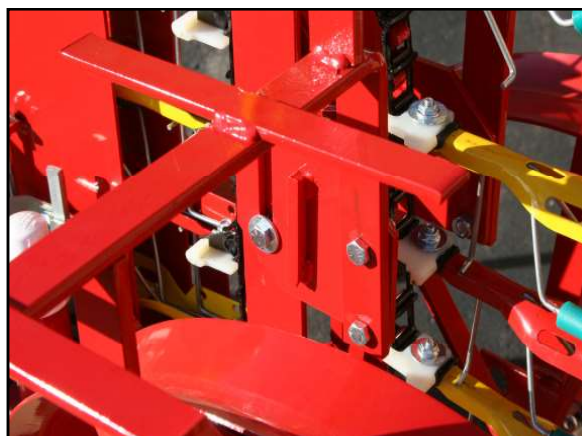

4. Use two 3/8 x 1" hex head bolts and two 3/8" nuts to attach plant stand frame to the slotted mounting bracket.



5. Attach the width adjustment plate with either the inside or outside hole depending on if you are using the wide (standard) plant boxes or the narrow with 3/8 x 1" hex head bolt and nut.

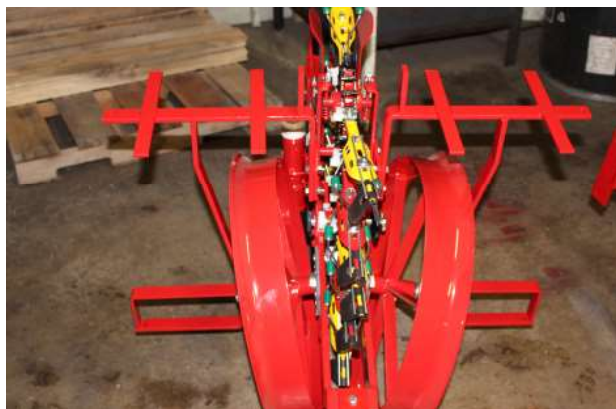

6. Install the plant boxes. These can be adjusted forward or backward for operator comfort.



Assembling the L-Shaped Seat Braces



1. Assemble the L-shaped seat brace by the chain guard. The sea brace mounts on the inside of the frame. The U-bolt mounts from the outside of the transplanter frame under the chain guard. Secure with 1/2" washers and 1/2" hex nuts over each threaded end.



2. The second L-shaped seat brace gets attached on the outside of the transplanter opposite the chain guard. The seat brace mounts on the outside of the frame with the U-bolt coming from the inside of the frame going outside through the seat brace. Secure with 1/2" washers and 1/2" hex nuts over each threaded end.

Mounting your Fiberglass or Cushion Seat

•Fiberglass Seats•



Fiberglass Seat - Turn your fiberglass seat over and remove any covers over the threaded studs. Take your green fiberglass seat bracket and mount it to the bottom of the seat with the side with the bend towards the front of the seat. Secure with four 1/4" hex nuts. Insert the 1/2 x 1-1/2 carriage bolt through the brace and then through the L-shaped seat bracket. Secure with a 1/2" washer and hex nut.

•Cushion Seats•

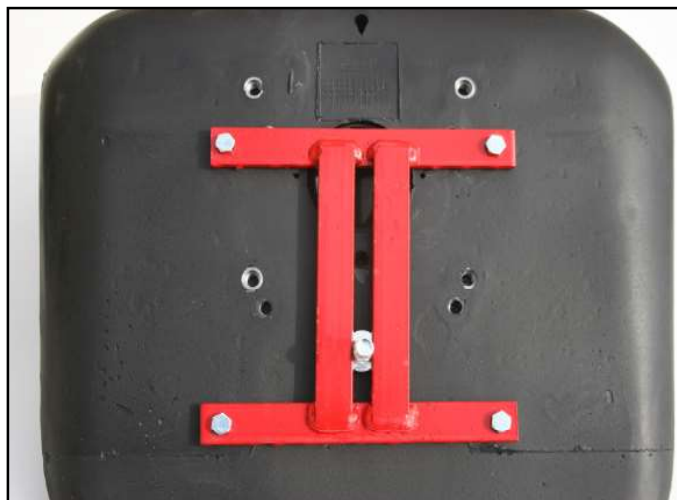

Cushion Seat - Slide the 1/2" x 1-1/2" carriage bolt through the bottom of the red seat bracket before mounting the seat bracket to the seat. After placing the carriage bolt through the seat bracket, place the seat bracket on the cushion seat. Secure with four 5/16" x 1" hex head bolts. Place the seat on the L-shaped seat bracket and secure with a 1/2" washer and hex nut.

Loose Pocket Assembly

If your Model 1000 was shipped in a crate, a pocket must be put on the empty attachment link.

The empty attachment link should be right at the top of the chain when the unit is shipped. If it is not, turn the drive wheel until the empty attachment link comes to the top.



Do NOT put #445 rubber gripper onto spring wires(#440) until pocket is assembled to attachment link.

Take the extra V-3 pocket that is wired onto unit and loosen the pocket bolt. Put pocket bolt through the attachment link. Make sure spacing bar stays under the head of the bolt. Place #375 water trip on the back of attachment link, then the 1/4" fender washer. Secure with 1/4" flange nut. After the bolt has been tightened, slide the top part of the #445 rubber gripper to the #440 wire.

Instructions for Direct Drive Clamps

The following instructions are for mounting the direct drive clamps to your Model 1000 unit. Although the pictures show the 2-1/2" clamps, use these instructions for any clamp style. They all mount the same way.



1. Insert a metal bushing from the inside of the frame. Put one of the 1/2 x 1-1/2" bolts through the bushing also from the inside.



2. Attach the clamp to the bolt in the **top** hole of the bottom set of large holes. Secure with a 1/2" hex nut.
3. If you have a Model 1000B-3 or 1000-2 follow directions below for one clamp side only. To mount safety bar on other clamp side, see page 11. In the **top** set of holes, place a 7/16 x 1-1/4" bolt through the top hole.

4. Slide the end link of the chain onto the bolt.
5. Secure the chain with a 3/8" washer and then a 7/16" hex nut. Make sure the nut is very tight.





6. Use the same instructions for the other side of the Direct Drive Wheel.

Note: The clamps may be reversed or fastened on the inside of the frame for narrow row spacings. Also, if other clamps are in the way, two lefts or two rights may be used. The lower holes on the clamps are for higher toolbars on older models or on tractors where 3-point hitch will not go low enough. Correct height of toolbar is 14" to center.

The Model 1000 unit can now be mounted to your 3-point hitch or toolbar. Following is a list of fasteners that you must use for various toolbars.

Toolbar Hardware List

- 2-1/2" or 2-1/4" Diamond toolbar - 7/8" V-bend U-bolt (2)
- 3" x 3" Flat Toolbar - 3/4" x 5" Hex bolts (4)
- 4" x 4" Flat Toolbar - 3/4" x 6" Hex bolts (4)
- 4" x 7" Toolbar - 3/4" x 9-1/2" Hex bolts (4)
- 5" x 7" Toolbar - 3/4" x 7" Hex bolts (4)
- 7" x 7" Toolbar - 3/4" x 9-1/2" (4)



Shown with clamps reversed

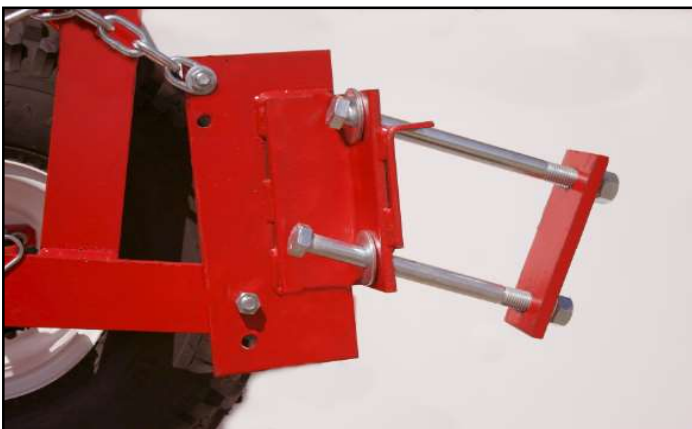

4 x 7 Toolbar Clamp. Use 2-3/4 x 9-1/2" hex bolts, 2-3/4" hex nuts and 2-3/4" washers.

Note: bent bracket on front of clamp

Model 1000B-3 Barrel Mounting & 3-Point Hitch Instructions



For B-3 Model, make sure the safety bar is properly installed!

To mount this safety bar, you must remove the 7/16 x 1-1/4" bolt from on side of the direct drive wheel.

1. Locate the special 2-1/2" stud in your bag of bolts and nuts.
2. Turn a 7/16" hex nut all the way onto the stud.
3. Put the 7/16" washer on the stud next to the nut.
4. Place the lift chain up against the washer.
5. Slide the stud through the hole on the Direct Drive frame and secure with a 7/16" hex nut.
6. Assemble another stud the same way and fasten it to the top hole of the front Direct Drive clamp.
7. Attach the red seat safety bar to the stud on your drive wheel. **The end with the hole must go on the clamp. The slotted end must go on the frame.** After the safety bar is attached, place the small clip pins through the small holes.

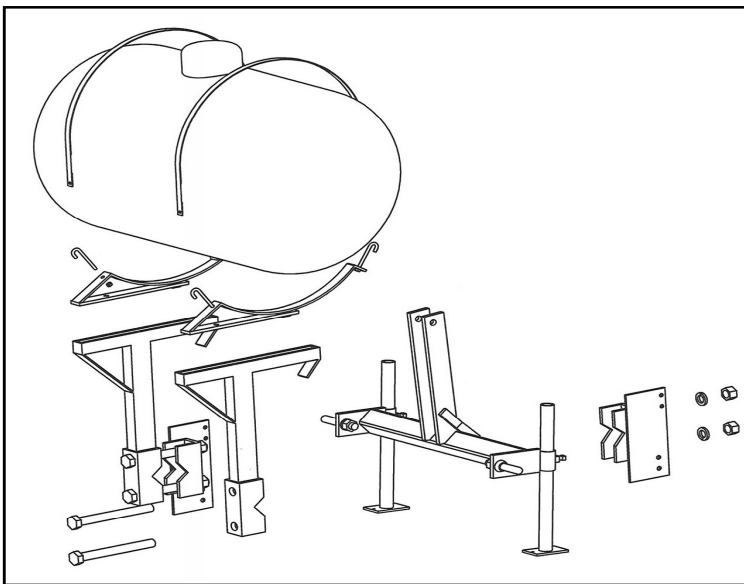

3-Point Hitch & Barrel Mounting

1. On the 3-point hitch, connect the Category I hitch pins through the holes on the outside of the hitch. Put the pins in through the outside and secure with the lock washer and hex nut included with the pin.
2. Slide the green pipe stands up through the pipes on the hitch, then tighten by turning the set screw.

Note: The following instructions will be easier with two people



3. Center the 3-point hitch toolbar with the clamps on your transplanter. Next, line up one of the barrel mounting brackets with the direct drive clamps. Secure using two 1 x 8-1/2 bolts and hex nuts. Do the same with the other barrel mounting bracket.



Side view of B-3 mountings



4. Bolt barrel hoops onto B-3 supports using 1/2 x 3" hex bolt with 1/2" lock nut. Note below: the hoops can be mounted in a forward or back position, depending on clearance that you need for the tractor fenders etc.



5. Screw in the nipple into the bottom of the tank.



6. Insert J-bolts into the four holes on the barrel hoops. It works best to thread 5/16" nut onto J-bolt before hooking up barrel hoops.



7. The 55 gallon poly tank can now be mounted on top of the barrel mountings. Use the four J-bolts and the galvanized straps to secure the barrel to the mountings.

A. Grease all fittings before the start of each day. Grease fittings are found:

1. On each packing wheel axle.
2. Upper pocket chain sprocket (Model 1000 only)
3. Direct drive tire hub (Direct Drive Units only)
4. On each nylon bushing on the pocket chain jackshaft.

B. Regulating Plant Depth

1. All operators should take care to see that the plants are placed well down in the pocket so the plant is held firmly.
2. The plant depth is regulated by the distance the root is extended out of the pocket.
3. To set the plants deeper, simply set the plant in the pocket with the roots further out than what is normally done. (See figure below)
4. If planting strawberries the axle must be raised up, allowing the transplanter unit to go deeper into the soil to cover the strawberry crowns.



V-3 Standard Plant Placement



Deeper Plant Placement

C. Pocket Chain Instructions

1. Make sure that bolts holding the upper sprocket on the pocket chain are not too tight. This will cause unnecessary friction on the unit and possible slippage on packing wheel drive transplanter. Simply loosen the wing nuts if the chain seems too tight.
2. Tighten the wing nuts equally by the top sprocket to keep the chain running level at all times.
3. If in row spacings of 20" or greater are needed, use only 6 pockets. You may remove every other pocket or leave them on. This gives the same speed or greater as a 12 pocket chain.

D. Adjusting or setting the #395R Round Point Shoe

Note: The shoe is preset at the factory for almost all situations.

Follow these instructions only if plants are leaning or in extreme wet or dry soil conditions.

1. Whenever any adjustments are made, be sure to get the shoe directly square and straight in front of the opening of the packing wheels. Make sure that the pockets will run through the middle of the shoe.
2. In loose dry soil, the shoe should be adjusted closer to the packing wheels. This can be done by adjusting the diagonal brace on the shoe.
3. In wet heavy soil, the shoe should be adjusted away from the packing wheels. Again, this can be done by adjusting the diagonal shoe brace.
4. Keep the shoe clean at all times. Do not allow dirt or trash to build up on the front or side of the shoe because this can cause too wide of a furrow that cannot be closed properly by the packing wheels. Poly covered shoes will eliminate this problem.

E. Water Valve Adjustment

1. For more water, make sure the valve is getting a full stroke by adjusting the #604 bracket on the pump rod. Make sure the valve does not over stroke. You should be able to lift the 604 rod 1/4-1/2" at the top of its stroke.
2. A broad range of adjustment can be achieved with the #603 water cam.
3. For wider spacings, the water cam may have to be raised so the water is on the plant. If the #603 is raised, be sure to raise the #604 water adjustment bracket accordingly and do not over stroke.

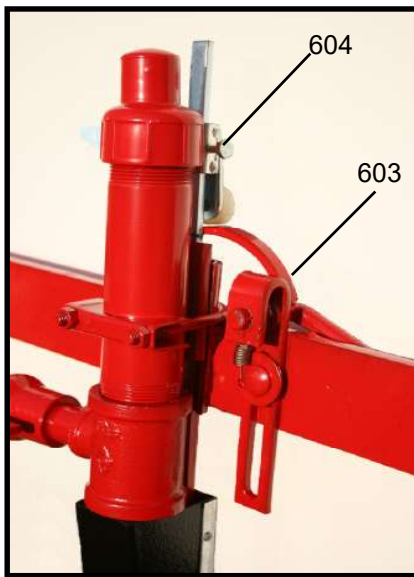

Example: At 20" row spacing, the #603 water cam should be adjusted nearly all the way up the slot. The #604 water adjustment must also be adjusted accordingly so a 1/2" remains on the 604 stroke.

4. Tilting the #603 water cam back towards the water trips on the pockets will create a longer stroke of water or more water before and after the plant.
5. Always empty the water out of the valve after quitting for the day. **Water freezing inside the valve will destroy the #610 and #612 balls inside the valve.**

F. Direct Drive Float Wheel Operation

1. Use only 4 to 5 pounds of air pressure in the Direct Drive Wheel during operation.



Wrong
Toolbar too high



Correct



Wrong
Toolbar too low

2. It is very important when starting to transplant, that the lift chains on the side of the Direct Drive Wheel are loose. See above "Correct" picture.
3. When lowering the transplanting unit into the ground, be sure that the frame members on the Direct Drive Wheel run parallel as is shown in the center picture. This is adjusted by the height of the hitch or toolbar (a pair of gauge wheels will eliminate adjustment of toolbar height).
4. Running the frame parallel will keep the lift chains loose allowing for proper floatation in the Direct Drive Wheel.
5. Running the frame members parallel and level will allow the packing wheels to run in the proper packing position.
6. Running the toolbar too low will tighten the back chains and cause the packing wheels to run too light and not pack the soil properly.
7. Running the toolbar too high will tighten the front lift chains and cause the Direct Drive Wheel to not run on the ground, especially through low spots.

Trouble Shooting

Important - Before attempting any of the following, make sure that the unit is running level or parallel to the ground. Do not run the front hitch or toolbar too far down or up. On all Model 1000 series units, make sure that the chains are loose on both sides of the arch bracket over the drive wheel. For all transplanter, make sure the soil is worked deep enough.

Problem

Solution

Packing wheels not packing properly

- A. Lengthen third arm on tractor to get float in hitch
- B. Hitch is too far down and needs to be lifted (lift chains are not loose)
- C. Clean off sides of shoe
- D. Work soil deeper
- E. Add weight to back of unit
- F. Poly shoes will eliminate soil building up on the outsides

Water leaks from top of water valve

- A. Check to see if the rubber nipple inside the top of the valve is in place and rounded.
- B. #610 ball inside the valve has collapsed and needs to be replaced.

Water leaks from bottom of water valve

- A. Rubber ball #612 on pin is broke and needs to be replaced
- B. The nylon nut on the bottom is broken and needs to be replaced

Water not uniform

- A. Make sure all the water trips on the pockets are in good shape and at even distances from the attachment link.
- B. Check to see that all springs on the water valve are in good working order.
- C. Water valve has dirt or residue build up that needs to be cleaned out

Water misses plants

•See water valve instructions on Page13.

Plants falling out of pocket

- A. Inspect the rubber grippers to make sure that they are not all stretched out.
- B. Tighten the L-bolts on the side of the guides.
- C. #482 pocket extensions may be needed if planting cell-type plants.
- D. Check bottom of guides to insure that the pocket is not releasing the plant too soon.

Plants on top of soil

- A. Cut back on water because the plants are floating up out of the shoe.
- B. Plants need to be pulled further out of the pocket to put them deeper.
- C. Too much loose soil is getting inside the shoe before the packing wheels can pack. Move shoe closer to packing wheels.
- D. A gap might be occurring by having the hitch too low causing the packing wheels to be up in the air or not being able to put enough pressure on the soil.
- E. Ground not worked deep enough causing the shoe to not go deep enough into the soil.

Plants leaning

- A. Need to put plant further in the pocket to keep it from hitting the bottom of the furrow.
- B. Possibility of needing a deeper shoe.
- C. May need #482 extensions to help support the cell of a plant coming from a tray.
- D. See Operating Instructions on Page 13 about adjusting the shoe.

Safety Precautions

1. Make sure tractor is stopped and in neutral with the transplanter lowered to the ground before getting on and off the unit.
2. No operator is allowed to be on the unit as it is raised and lowered.
3. No operator is allowed on the transplanter as it is transported to or from the field.
4. All operators must be seated before movement begins and remain seated until the transplanter is completely stopped.
5. Never leave the transplanter in the raised position.
6. Keep all shields and guards in place when operating the transplanter.
7. Never attempt repairs or maintenance while the transplanter is in motion.
8. Never put the tractor in reverse while the transplanter is on the ground.
9. Follow all safety instructions supplied by the tractor manufacturer to which the transplanter is mounted.

MACHINE IMPROVEMENTS

MECHANICAL TRANSPLANTER CO. IS ALWAYS STRIVING TO MAKE IMPROVEMENTS ON THEIR LINE OF EQUIPMENT. MECHANICAL TRANSPLANTER CO. RESERVES THE RIGHT TO MAKE IMPROVEMENTS AND CHANGES AT ANY TIME WITHOUT INCURRING OBLIGATIONS TO MAKE SUCH CHANGES OR ADDITIONS TO EQUIPMENT PREVIOUSLY SOLD.

Limited Warranty

Mechanical Transplanter Company warrants each item of new equipment manufactured by Mechanical to be free from defects in material and workmanship under normal use and service.

The obligation of Mechanical Transplanter Company under this LIMITED WARRANTY is limited to repairing or replacing as Mechanical may elect, and any parts that prove, in Mechanical's judgment, to be defective in material and workmanship within the first season's use or 45 consecutive days after initially placing equipment in operation, whichever occurs first. Any outside work or alterations without Mechanical's written approval will render the LIMITED WARRANTY void.

Mechanical's obligation specifically excludes any liability for consequential damages, such as loss of profits, delays, expenses, damage to goods or property used in connection with or processed in or by the product sold, or damage to the product sold from whatsoever cause, whether or not such loss is due to negligence of selling dealer of Mechanical Transplanter Company.

This limited warranty shall not apply to any item or machine which shall have been operated in a manner not recommended by the Company nor which shall have been repaired, altered, misused, damaged in an accident, neglected, tampered with or used in any way which in the Company's opinion adversely affects its performance and results.

No person is authorized to give any other warranties or to assume any other liability on behalf of Mechanical Transplanter Company, unless made in writing by Mechanical.

This limited warranty covers repair or replacement of Mechanical Transplanter Co. equipment only and does not cover crop loss, downtime, labor, damage to other equipment, etc.

This limited warranty does not apply to exterior finishes, tires, chain links, bearings, or any other items sold by Mechanical Transplanter Co., but warranted by the original manufacturer except to the extent of their individual manufacturer's warranty.

THIS LIMITED WARRANTY IS IN LIEU OF ALL OTHER WARRANTIES, EXPRESSED OR IMPLIED. WARRANTIES OF MERCHANTABILITY AND FITNESS FOR PARTICULAR PURPOSE ARE EXCLUDED, AS ARE ALL OTHER REPRESENTATIONS TO THE USER-PURCHASER, AND ALL OTHER OBLIGATIONS OR LIABILITIES, INCLUDING LIABILITY FOR INCIDENTAL AND CONSEQUENTIAL DAMAGES, ON THE PART OF MECHANICAL OR THE SELLER.

Mechanical Transplanter Co.

Model 1000 and 1000B-3

Operators Manual



Mechanical Transplanter Co., LLC
1150 Central Avenue • Holland, MI 49423-5230
Phone: 616-396-8738 • Fax: 616-396-3619
website: www.mechanicaltransplanter.com
e-mail: mtc@mechanicaltransplanter.com

Spacing Charts and Information

| SPACING CHART FOR DIRECT DRIVE UNIT W/ 12 POCKET CHAIN | | | | | | |
|---|---------------------------------|-------------------------------------|-----------------------|-----------------------|-------------------|-----------------|
| Sprocket on OUT-SIDE of Jackshaft | Sprocket on INSIDE of Jackshaft | Number of Teeth on Sprocket on Unit | | | | |
| | | 7 | 8 | 9 | 10 | 11 |
| 7 | 11 | 6" 15.2cm | 6-1/2" - 7" 17.8cm | 7-1/2" - 8" 20.3cm | 8-1/2" 21.6cm | 9" 22.8cm |
| 7 | 7 | 9" 22.8cm | 10-1/2" 26.7cm | 13" 33cm | 15" 38.1cm | 16" 40.6cm |
| 8 | 7 | 10-1/2" 26.7cm | 12-1/2" 31.7cm | 14" 35.5cm | 15" 38.1cm | 16" 40.6cm |
| 9 | 7 | 12" 30.5cm | 13-1/2" 34.3cm | 15" 38.1cm | 17" 43.2cm | 18-1/2" 47cm |
| 10 | 7 | 13" 33cm | 14" 35.5cm | 15-1/2" 39.4cm | 17-1/2" 44.5cm | 20-1/2" 52cm |
| 11 | 7 | 15" 38.1cm | 18" 45.7cm | | | |

Double any of the above spacings by using every other pocket (6 pocket).
Make sure HITCH and UNIT are level or parallel to the ground when planting.

Use for Model 1000

| DISC SPACING CHART FOR MODELS W/ DIRECT DRIVE | | | | | | | |
|--|---------------------------------|-------------------------------|-------------------------------------|--------|--------|--------|--------|
| Sprocket on OUTSIDE of Jackshaft | Sprocket on INSIDE of Jackshaft | Number of Pockets on the Disc | Number of Teeth on Sprocket by Disc | | | | |
| | | | 7 | 8 | 9 | 10 | 11 |
| 7 | 7 | 24 | | 2" | 2-1/4" | 2-1/2" | 2-3/4" |
| | | 16 | 3" | 3-1/4" | 3-1/2" | 4" | 4-1/2" |
| | | 12 | | 4-3/4" | 5-1/4" | 5-3/4" | 6-1/4" |
| 8 | 7 | 24 | | 2-1/2" | 3" | 3-1/4" | 3-1/2" |
| | | 16 | 3-1/2" | 3-3/4" | 4-1/4" | 4-1/2" | 5-1/4" |
| | | 12 | | 6" | 6-1/4" | 6-3/4" | 7" |
| 9 | 7 | 24 | 2-1/2" | 2-3/4" | 3-1/4" | 3-1/2" | 4" |
| | | 16 | 3-3/4" | 4-1/4" | 4-1/2" | 5" | 5-1/2" |
| | | 12 | 4-1/2" | 6-1/4" | 6-1/2" | 7-1/4" | 8" |
| 10 | 7 | 24 | 2-1/2" | 3" | 3-1/2" | 3-3/4" | 4-1/2" |
| | | 16 | 3-3/4" | 4-1/2" | 5-1/4" | | |
| | | 12 | 5-1/4" | 6" | 7" | 7-1/2" | 8-1/2" |
| 11 | 7 | 24 | 2-1/2" | 3" | 3-1/2" | 4-1/4" | 4-3/4" |
| | | 16 | 4" | 5" | 6" | | |
| | | 12 | 5-1/2" | 6-1/2" | 7-1/2" | 9" | 10" |

Use for Model 1000 with disc mounted pockets

Assembly Instructions

For Model 1000 Series Transplanters

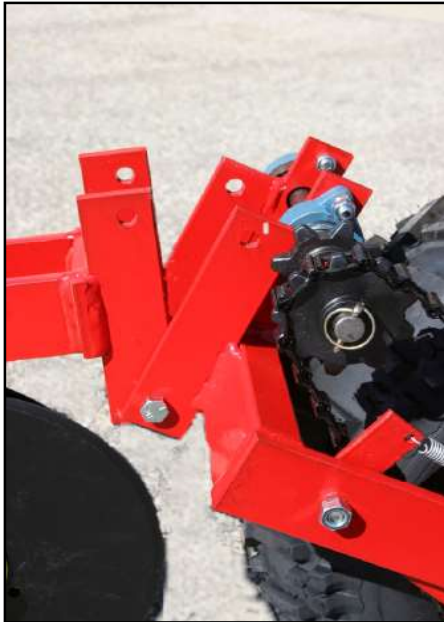

1. Bolt on the Direct Drive Float Wheel using the four 1/2 x 1-1/2 " bolts. Secure using the 1/2" hex nuts.



2. Remove the following parts from the direct drive wheel jackshaft: Clip pin, drive chain coming from the wheel, outside sprocket on jackshaft, and pipe spacer. Then remove the extra top hex nut located on the flange bearing.



3. Install the inside chain guard of the unit. Fasten front short tab to the top bolt on flange bearing from #2 photo with hex nut. The long tab attaches to the empty hole on the transplanter frame by the packing wheels. The guard must fit between the shoe brace and the guide adjustment bolt. Use the 3/8 x 1" bolt and a 3/8" hex nut to secure.

4. Select the proper sprocket arrangement for the spacing needed between plants. Look on page 2 or the chart on the side of your transplanter for the correct arrangement. For spacings using 11 tooth sprockets, extra chain links may be needed to lengthen the drive chain. These links are wired to the lift chain by the drive wheel. After finding the correct sprockets, run the long drive chain from the sprocket on the pocket chain shaft to the inside sprocket on the jackshaft of the direct drive wheel. The chain must go over the idler sprocket on the shoe brace and under the chain tightener sprocket as shown in the photo below.



5. Slide the red pipe spacer back onto the jackshaft. Insert the roll pin back into the second hole from the outside of the jackshaft. Slide the outside sprocket over the roll pin. Slide the drive chain coming from the drive wheel over the outside jackshaft sprocket. You may have to use your hand to push the chain tightener up to create enough slack in the chain. Insert the clip pin into the outside hole of the jackshaft.



6. Slide the outside chain guard onto the two pins and secure with clip pins.

Installation of Plant Stands

It is very important to know what row width will be used before installing the plant stands on multi-row transplanter. Follow the chart below.

- 42" Row Spacing - All Wide Plant Boxes
- 41" to 36" Row Spacing - Narrow Plant Boxes Inside
- 35" to 24" Row Spacing - One Wide Inside & Two Wide Outside
- 23" to 21" Row Spacing - One Narrow Inside & Two Wide Outside
- Less than 21" Row Spacing - Wide Outside Plant Boxes Only



1. Remove the long bolt between the uprights by the pocket chain. Do not lose the spacer between the uprights. Remove the outside cotter key in each axle.



2. Install the slotted mounting plates on both sides of the planter using the long bolt just removed. Do not tighten until the plant stand is fully assembled.



3. Slide plant stand onto the packing wheel axle and insert cotter key. Bend cotter key ends to keep in place.

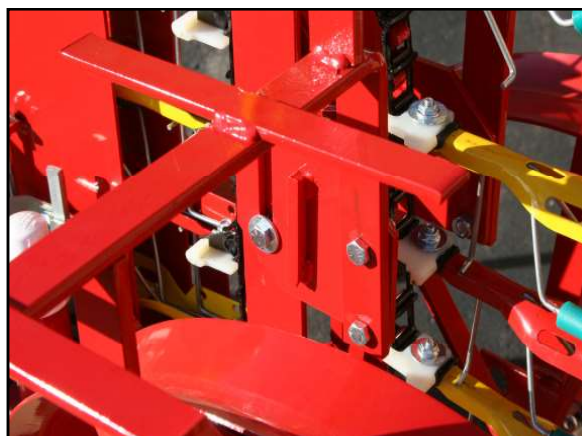

4. Use two 3/8 x 1" hex head bolts and two 3/8" nuts to attach plant stand frame to the slotted mounting bracket.



5. Attach the width adjustment plate with either the inside or outside hole depending on if you are using the wide (standard) plant boxes or the narrow with 3/8 x 1" hex head bolt and nut.



6. Install the plant boxes. These can be adjusted forward or backward for operator comfort.



Assembling the L-Shaped Seat Braces



1. Assemble the L-shaped seat brace by the chain guard. The sea brace mounts on the inside of the frame. The U-bolt mounts from the outside of the transplanter frame under the chain guard. Secure with 1/2" washers and 1/2" hex nuts over each threaded end.



2. The second L-shaped seat brace gets attached on the outside of the transplanter opposite the chain guard. The seat brace mounts on the outside of the frame with the U-bolt coming from the inside of the frame going outside through the seat brace. Secure with 1/2" washers and 1/2" hex nuts over each threaded end.

Mounting your Fiberglass or Cushion Seat

•Fiberglass Seats•



Fiberglass Seat - Turn your fiberglass seat over and remove any covers over the threaded studs. Take your green fiberglass seat bracket and mount it to the bottom of the seat with the side with the bend towards the front of the seat. Secure with four 1/4" hex nuts. Insert the 1/2 x 1-1/2 carriage bolt through the brace and then through the L-shaped seat bracket. Secure with a 1/2" washer and hex nut.

•Cushion Seats•

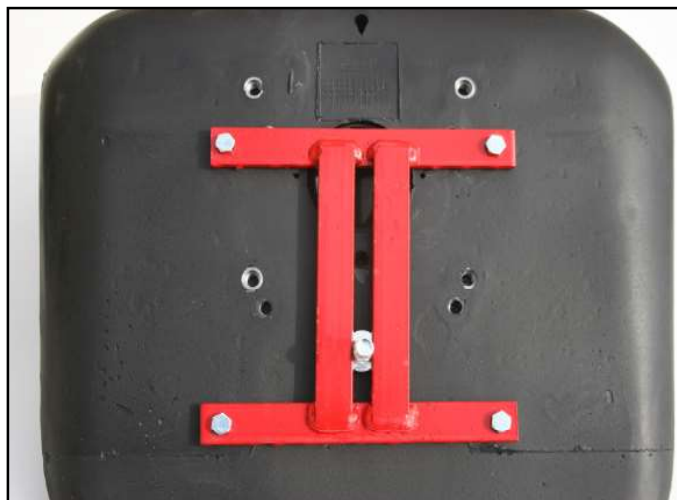

Cushion Seat - Slide the 1/2" x 1-1/2" carriage bolt through the bottom of the red seat bracket before mounting the seat bracket to the seat. After placing the carriage bolt through the seat bracket, place the seat on the L-shaped seat bracket and secure with a 1/2" washer and hex nut.

Loose Pocket Assembly

If your Model 1000 was shipped in a crate, a pocket must be put on the empty attachment link.

The empty attachment link should be right at the top of the chain when the unit is shipped. If it is not, turn the drive wheel until the empty attachment link comes to the top.



Do NOT put #445 rubber gripper onto spring wires(#440) until pocket is assembled to attachment link.

Take the extra V-3 pocket that is wired onto unit and loosen the pocket bolt. Put pocket bolt through the attachment link. Make sure spacing bar stays under the head of the bolt. Place #375 water trip on the back of attachment link, then the 1/4" fender washer. Secure with 1/4" flange nut. After the bolt has been tightened, slide the top part of the #445 rubber gripper to the #440 wire.

Instructions for Direct Drive Clamps

The following instructions are for mounting the direct drive clamps to your Model 1000 unit. Although the pictures show the 2-1/2" clamps, use these instructions for any clamp style. They all mount the same way.



1. Insert a metal bushing from the inside of the frame. Put one of the 1/2 x 1-1/2" bolts through the bushing also from the inside.



2. Attach the clamp to the bolt in the **top** hole of the bottom set of large holes. Secure with a 1/2" hex nut.
3. If you have a Model 1000B-3 or 1000-2 follow directions below for one clamp side only. To mount safety bar on other clamp side, see page 11. In the **top** set of holes, place a 7/16 x 1-1/4" bolt through the top hole.

4. Slide the end link of the chain onto the bolt.
5. Secure the chain with a 3/8" washer and then a 7/16" hex nut. Make sure the nut is very tight.





6. Use the same instructions for the other side of the Direct Drive Wheel.

Note: The clamps may be reversed or fastened on the inside of the frame for narrow row spacings. Also, if other clamps are in the way, two lefts or two rights may be used. The lower holes on the clamps are for higher toolbars on older models or on tractors where 3-point hitch will not go low enough. Correct height of toolbar is 14" to center.

The Model 1000 unit can now be mounted to your 3-point hitch or toolbar. Following is a list of fasteners that you must use for various toolbars.

Toolbar Hardware List

- 2-1/2" or 2-1/4" Diamond toolbar - 7/8" V-bend U-bolt (2)
- 3" x 3" Flat Toolbar - 3/4" x 5" Hex bolts (4)
- 4" x 4" Flat Toolbar - 3/4" x 6" Hex bolts (4)
- 4" x 7" Toolbar - 3/4" x 9-1/2" Hex bolts (4)
- 5" x 7" Toolbar - 3/4" x 7" Hex bolts (4)
- 7" x 7" Toolbar - 3/4" x 9-1/2" (4)



Shown with clamps reversed

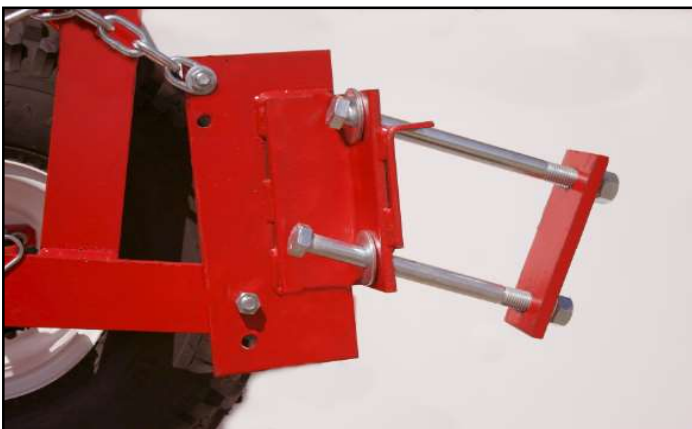

4 x 7 Toolbar Clamp. Use 2-3/4 x 9-1/2" hex bolts, 2-3/4" hex nuts and 2-3/4" washers.

Note: bent bracket on front of clamp

Model 1000B-3 Barrel Mounting & 3-Point Hitch Instructions



For B-3 Model, make sure the safety bar is properly installed!

To mount this safety bar, you must remove the 7/16 x 1-1/4" bolt from on side of the direct drive wheel.

1. Locate the special 2-1/2" stud in your bag of bolts and nuts.
2. Turn a 7/16" hex nut all the way onto the stud.
3. Put the 7/16" washer on the stud next to the nut.
4. Place the lift chain up against the washer.
5. Slide the stud through the hole on the Direct Drive frame and secure with a 7/16" hex nut.
6. Assemble another stud the same way and fasten it to the top hole of the front Direct Drive clamp.
7. Attach the red seat safety bar to the stud on your drive wheel. **The end with the hole must go on the clamp. The slotted end must go on the frame.** After the safety bar is attached, place the small clip pins through the small holes.

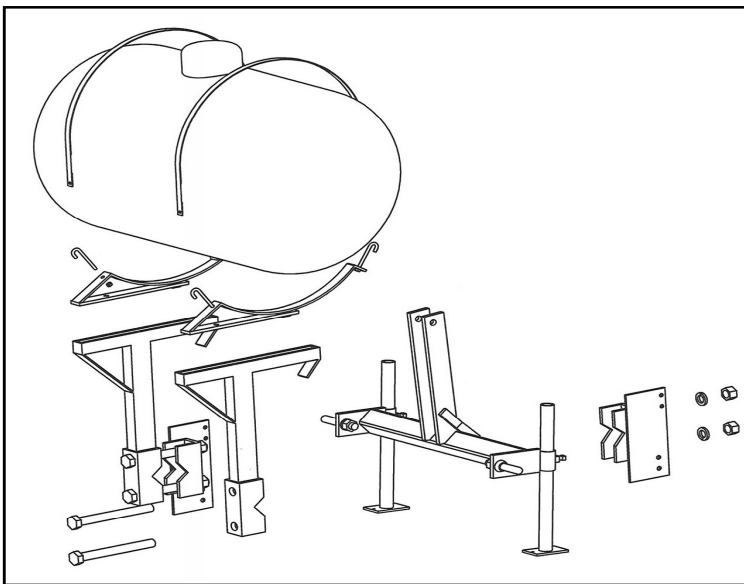

3-Point Hitch & Barrel Mounting

1. On the 3-point hitch, connect the Category I hitch pins through the holes on the outside of the hitch. Put the pins in through the outside and secure with the lock washer and hex nut included with the pin.
2. Slide the green pipe stands up through the pipes on the hitch, then tighten by turning the set screw.

Note: The following instructions will be easier with two people



3. Center the 3-point hitch toolbar with the clamps on your transplanter. Next, line up one of the barrel mounting brackets with the direct drive clamps. Secure using two 1 x 8-1/2 bolts and hex nuts. Do the same with the other barrel mounting bracket.



Side view of B-3 mountings



4. Bolt barrel hoops onto B-3 supports using 1/2 x 3" hex bolt with 1/2" lock nut. Note below: the hoops can be mounted in a forward or back position, depending on clearance that you need for the tractor fenders etc.



5. Screw in the nipple into the bottom of the tank.



6. Insert J-bolts into the four holes on the barrel hoops. It works best to thread 5/16" nut onto J-bolt before hooking up barrel hoops.



7. The 55 gallon poly tank can now be mounted on top of the barrel mountings. Use the four J-bolts and the galvanized straps to secure the barrel to the mountings.

A. Grease all fittings before the start of each day. Grease fittings are found:

1. On each packing wheel axle.
2. Upper pocket chain sprocket (Model 1000 only)
3. Direct drive tire hub (Direct Drive Units only)
4. On each nylon bushing on the pocket chain jackshaft.

B. Regulating Plant Depth

1. All operators should take care to see that the plants are placed well down in the pocket so the plant is held firmly.
2. The plant depth is regulated by the distance the root is extended out of the pocket.
3. To set the plants deeper, simply set the plant in the pocket with the roots further out than what is normally done. (See figure below)
4. If planting strawberries the axle must be raised up, allowing the transplanter unit to go deeper into the soil to cover the strawberry crowns.



V-3 Standard Plant Placement



Deeper Plant Placement

C. Pocket Chain Instructions

1. Make sure that bolts holding the upper sprocket on the pocket chain are not too tight. This will cause unnecessary friction on the unit and possible slippage on packing wheel drive transplanter. Simply loosen the wing nuts if the chain seems too tight.
2. Tighten the wing nuts equally by the top sprocket to keep the chain running level at all times.
3. If in row spacings of 20" or greater are needed, use only 6 pockets. You may remove every other pocket or leave them on. This gives the same speed or greater as a 12 pocket chain.

D. Adjusting or setting the #395R Round Point Shoe

Note: The shoe is preset at the factory for almost all situations.

Follow these instructions only if plants are leaning or in extreme wet or dry soil conditions.

1. Whenever any adjustments are made, be sure to get the shoe directly square and straight in front of the opening of the packing wheels. Make sure that the pockets will run through the middle of the shoe.
2. In loose dry soil, the shoe should be adjusted closer to the packing wheels. This can be done by adjusting the diagonal brace on the shoe.
3. In wet heavy soil, the shoe should be adjusted away from the packing wheels. Again, this can be done by adjusting the diagonal shoe brace.
4. Keep the shoe clean at all times. Do not allow dirt or trash to build up on the front or side of the shoe because this can cause too wide of a furrow that cannot be closed properly by the packing wheels. Poly covered shoes will eliminate this problem.

E. Water Valve Adjustment

1. For more water, make sure the valve is getting a full stroke by adjusting the #604 bracket on the pump rod. Make sure the valve does not over stroke. You should be able to lift the 604 rod 1/4-1/2" at the top of its stroke.
2. A broad range of adjustment can be achieved with the #603 water cam.
3. For wider spacings, the water cam may have to be raised so the water is on the plant. If the #603 is raised, be sure to raise the #604 water adjustment bracket accordingly and do not over stroke.

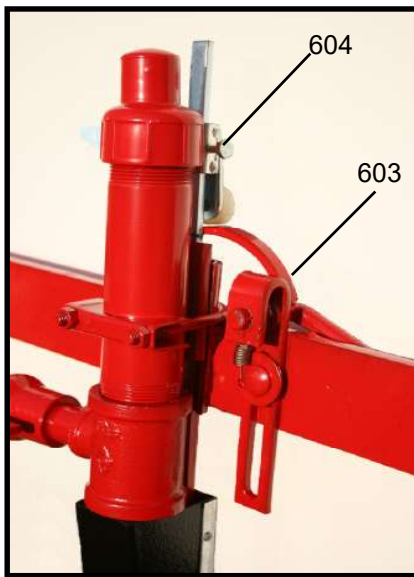

Example: At 20" row spacing, the #603 water cam should be adjusted nearly all the way up the slot. The #604 water adjustment must also be adjusted accordingly so a 1/2" remains on the 604 stroke.

4. Tilting the #603 water cam back towards the water trips on the pockets will create a longer stroke of water or more water before and after the plant.
5. Always empty the water out of the valve after quitting for the day. **Water freezing inside the valve will destroy the #610 and #612 balls inside the valve.**

F. Direct Drive Float Wheel Operation

1. Use only 4 to 5 pounds of air pressure in the Direct Drive Wheel during operation.



Wrong
Toolbar too high



Correct



Wrong
Toolbar too low

2. It is very important when starting to transplant, that the lift chains on the side of the Direct Drive Wheel are loose. See above "Correct" picture.
3. When lowering the transplanting unit into the ground, be sure that the frame members on the Direct Drive Wheel run parallel as is shown in the center picture. This is adjusted by the height of the hitch or toolbar (a pair of gauge wheels will eliminate adjustment of toolbar height).
4. Running the frame parallel will keep the lift chains loose allowing for proper floatation in the Direct Drive Wheel.
5. Running the frame members parallel and level will allow the packing wheels to run in the proper packing position.
6. Running the toolbar too low will tighten the back chains and cause the packing wheels to run too light and not pack the soil properly.
7. Running the toolbar too high will tighten the front lift chains and cause the Direct Drive Wheel to not run on the ground, especially through low spots.

Trouble Shooting

Important - Before attempting any of the following, make sure that the unit is running level or parallel to the ground. Do not run the front hitch or toolbar too far down or up. On all Model 1000 series units, make sure that the chains are loose on both sides of the arch bracket over the drive wheel. For all transplanter, make sure the soil is worked deep enough.

Problem

Solution

Packing wheels not packing properly

- A. Lengthen third arm on tractor to get float in hitch
- B. Hitch is too far down and needs to be lifted (lift chains are not loose)
- C. Clean off sides of shoe
- D. Work soil deeper
- E. Add weight to back of unit
- F. Poly shoes will eliminate soil building up on the outsides

Water leaks from top of water valve

- A. Check to see if the rubber nipple inside the top of the valve is in place and rounded.
- B. #610 ball inside the valve has collapsed and needs to be replaced.

Water leaks from bottom of water valve

- A. Rubber ball #612 on pin is broke and needs to be replaced
- B. The nylon nut on the bottom is broken and needs to be replaced

Water not uniform

- A. Make sure all the water trips on the pockets are in good shape and at even distances from the attachment link.
- B. Check to see that all springs on the water valve are in good working order.
- C. Water valve has dirt or residue build up that needs to be cleaned out

Water misses plants

•See water valve instructions on Page13.

Plants falling out of pocket

- A. Inspect the rubber grippers to make sure that they are not all stretched out.
- B. Tighten the L-bolts on the side of the guides.
- C. #482 pocket extensions may be needed if planting cell-type plants.
- D. Check bottom of guides to insure that the pocket is not releasing the plant too soon.

Plants on top of soil

- A. Cut back on water because the plants are floating up out of the shoe.
- B. Plants need to be pulled further out of the pocket to put them deeper.
- C. Too much loose soil is getting inside the shoe before the packing wheels can pack. Move shoe closer to packing wheels.
- D. A gap might be occurring by having the hitch too low causing the packing wheels to be up in the air or not being able to put enough pressure on the soil.
- E. Ground not worked deep enough causing the shoe to not go deep enough into the soil.

Plants leaning

- A. Need to put plant further in the pocket to keep it from hitting the bottom of the furrow.
- B. Possibility of needing a deeper shoe.
- C. May need #482 extensions to help support the cell of a plant coming from a tray.
- D. See Operating Instructions on Page 13 about adjusting the shoe.

Safety Precautions

1. Make sure tractor is stopped and in neutral with the transplanter lowered to the ground before getting on and off the unit.
2. No operator is allowed to be on the unit as it is raised and lowered.
3. No operator is allowed on the transplanter as it is transported to or from the field.
4. All operators must be seated before movement begins and remain seated until the transplanter is completely stopped.
5. Never leave the transplanter in the raised position.
6. Keep all shields and guards in place when operating the transplanter.
7. Never attempt repairs or maintenance while the transplanter is in motion.
8. Never put the tractor in reverse while the transplanter is on the ground.
9. Follow all safety instructions supplied by the tractor manufacturer to which the transplanter is mounted.

MACHINE IMPROVEMENTS

MECHANICAL TRANSPLANTER CO. IS ALWAYS STRIVING TO MAKE IMPROVEMENTS ON THEIR LINE OF EQUIPMENT. MECHANICAL TRANSPLANTER CO. RESERVES THE RIGHT TO MAKE IMPROVEMENTS AND CHANGES AT ANY TIME WITHOUT INCURRING OBLIGATIONS TO MAKE SUCH CHANGES OR ADDITIONS TO EQUIPMENT PREVIOUSLY SOLD.

Limited Warranty

Mechanical Transplanter Company warrants each item of new equipment manufactured by Mechanical to be free from defects in material and workmanship under normal use and service.

The obligation of Mechanical Transplanter Company under this LIMITED WARRANTY is limited to repairing or replacing as Mechanical may elect, and any parts that prove, in Mechanical's judgment, to be defective in material and workmanship within the first season's use or 45 consecutive days after initially placing equipment in operation, whichever occurs first. Any outside work or alterations without Mechanical's written approval will render the LIMITED WARRANTY void.

Mechanical's obligation specifically excludes any liability for consequential damages, such as loss of profits, delays, expenses, damage to goods or property used in connection with or processed in or by the product sold, or damage to the product sold from whatsoever cause, whether or not such loss is due to negligence of selling dealer of Mechanical Transplanter Company.

This limited warranty shall not apply to any item or machine which shall have been operated in a manner not recommended by the Company nor which shall have been repaired, altered, misused, damaged in an accident, neglected, tampered with or used in any way which in the Company's opinion adversely affects its performance and results.

No person is authorized to give any other warranties or to assume any other liability on behalf of Mechanical Transplanter Company, unless made in writing by Mechanical.

This limited warranty covers repair or replacement of Mechanical Transplanter Co. equipment only and does not cover crop loss, downtime, labor, damage to other equipment, etc.

This limited warranty does not apply to exterior finishes, tires, chain links, bearings, or any other items sold by Mechanical Transplanter Co., but warranted by the original manufacturer except to the extent of their individual manufacturer's warranty.

THIS LIMITED WARRANTY IS IN LIEU OF ALL OTHER WARRANTIES, EXPRESSED OR IMPLIED. WARRANTIES OF MERCHANTABILITY AND FITNESS FOR PARTICULAR PURPOSE ARE EXCLUDED, AS ARE ALL OTHER REPRESENTATIONS TO THE USER-PURCHASER, AND ALL OTHER OBLIGATIONS OR LIABILITIES, INCLUDING LIABILITY FOR INCIDENTAL AND CONSEQUENTIAL DAMAGES, ON THE PART OF MECHANICAL OR THE SELLER.

Mechanical Transplanter Co.

Model 1000 and 1000B-3

Operators Manual



Mechanical Transplanter Co., LLC
1150 Central Avenue • Holland, MI 49423-5230
Phone: 616-396-8738 • Fax: 616-396-3619
website: www.mechanicaltransplanter.com
e-mail: mtc@mechanicaltransplanter.com

Spacing Charts and Information

| SPACING CHART FOR DIRECT DRIVE UNIT W/ 12 POCKET CHAIN | | | | | | |
|---|---------------------------------|-------------------------------------|-----------------------|-----------------------|-------------------|-----------------|
| Sprocket on OUT-SIDE of Jackshaft | Sprocket on INSIDE of Jackshaft | Number of Teeth on Sprocket on Unit | | | | |
| | | 7 | 8 | 9 | 10 | 11 |
| 7 | 11 | 6" 15.2cm | 6-1/2" - 7" 17.8cm | 7-1/2" - 8" 20.3cm | 8-1/2" 21.6cm | 9" 22.8cm |
| 7 | 7 | 9" 22.8cm | 10-1/2" 26.7cm | 13" 33cm | 15" 38.1cm | 16" 40.6cm |
| 8 | 7 | 10-1/2" 26.7cm | 12-1/2" 31.7cm | 14" 35.5cm | 15" 38.1cm | 16" 40.6cm |
| 9 | 7 | 12" 30.5cm | 13-1/2" 34.3cm | 15" 38.1cm | 17" 43.2cm | 18-1/2" 47cm |
| 10 | 7 | 13" 33cm | 14" 35.5cm | 15-1/2" 39.4cm | 17-1/2" 44.5cm | 20-1/2" 52cm |
| 11 | 7 | 15" 38.1cm | 18" 45.7cm | | | |

Double any of the above spacings by using every other pocket (6 pocket).
Make sure HITCH and UNIT are level or parallel to the ground when planting.

Use for Model 1000

| DISC SPACING CHART FOR MODELS W/ DIRECT DRIVE | | | | | | | |
|--|---------------------------------|-------------------------------|-------------------------------------|--------|--------|--------|--------|
| Sprocket on OUTSIDE of Jackshaft | Sprocket on INSIDE of Jackshaft | Number of Pockets on the Disc | Number of Teeth on Sprocket by Disc | | | | |
| | | | 7 | 8 | 9 | 10 | 11 |
| 7 | 7 | 24 | | 2" | 2-1/4" | 2-1/2" | 2-3/4" |
| | | 16 | 3" | 3-1/4" | 3-1/2" | 4" | 4-1/2" |
| | | 12 | | 4-3/4" | 5-1/4" | 5-3/4" | 6-1/4" |
| 8 | 7 | 24 | | 2-1/2" | 3" | 3-1/4" | 3-1/2" |
| | | 16 | 3-1/2" | 3-3/4" | 4-1/4" | 4-1/2" | 5-1/4" |
| | | 12 | | 6" | 6-1/4" | 6-3/4" | 7" |
| 9 | 7 | 24 | 2-1/2" | 2-3/4" | 3-1/4" | 3-1/2" | 4" |
| | | 16 | 3-3/4" | 4-1/4" | 4-1/2" | 5" | 5-1/2" |
| | | 12 | 4-1/2" | 6-1/4" | 6-1/2" | 7-1/4" | 8" |
| 10 | 7 | 24 | 2-1/2" | 3" | 3-1/2" | 3-3/4" | 4-1/2" |
| | | 16 | 3-3/4" | 4-1/2" | 5-1/4" | | |
| | | 12 | 5-1/4" | 6" | 7" | 7-1/2" | 8-1/2" |
| 11 | 7 | 24 | 2-1/2" | 3" | 3-1/2" | 4-1/4" | 4-3/4" |
| | | 16 | 4" | 5" | 6" | | |
| | | 12 | 5-1/2" | 6-1/2" | 7-1/2" | 9" | 10" |

Use for Model 1000 with disc mounted pockets

Assembly Instructions

For Model 1000 Series Transplanters

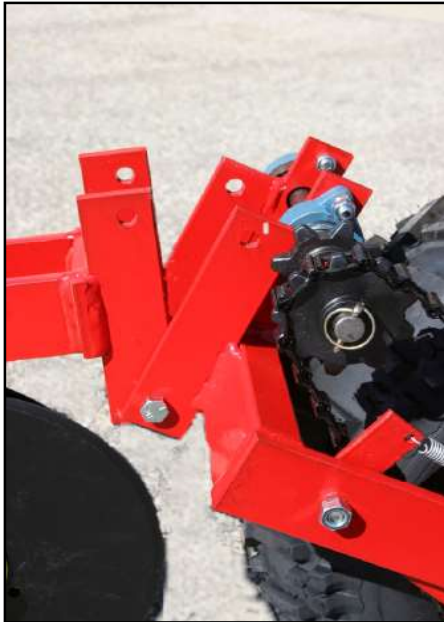

1. Bolt on the Direct Drive Float Wheel using the four 1/2 x 1-1/2 " bolts. Secure using the 1/2" hex nuts.



2. Remove the following parts from the direct drive wheel jackshaft: Clip pin, drive chain coming from the wheel, outside sprocket on jackshaft, and pipe spacer. Then remove the extra top hex nut located on the flange bearing.



3. Install the inside chain guard of the unit. Fasten front short tab to the top bolt on flange bearing from #2 photo with hex nut. The long tab attaches to the empty hole on the transplanter frame by the packing wheels. The guard must fit between the shoe brace and the guide adjustment bolt. Use the 3/8 x 1" bolt and a 3/8" hex nut to secure.

4. Select the proper sprocket arrangement for the spacing needed between plants. Look on page 2 or the chart on the side of your transplanter for the correct arrangement. For spacings using 11 tooth sprockets, extra chain links may be needed to lengthen the drive chain. These links are wired to the lift chain by the drive wheel. After finding the correct sprockets, run the long drive chain from the sprocket on the pocket chain shaft to the inside sprocket on the jackshaft of the direct drive wheel. The chain must go over the idler sprocket on the shoe brace and under the chain tightener sprocket as shown in the photo below.



5. Slide the red pipe spacer back onto the jackshaft. Insert the roll pin back into the second hole from the outside of the jackshaft. Slide the outside sprocket over the roll pin. Slide the drive chain coming from the drive wheel over the outside jackshaft sprocket. You may have to use your hand to push the chain tightener up to create enough slack in the chain. Insert the clip pin into the outside hole of the jackshaft.



6. Slide the outside chain guard onto the two pins and secure with clip pins.

Installation of Plant Stands

It is very important to know what row width will be used before installing the plant stands on multi-row transplanter. Follow the chart below.

- 42" Row Spacing - All Wide Plant Boxes
- 41" to 36" Row Spacing - Narrow Plant Boxes Inside
- 35" to 24" Row Spacing - One Wide Inside & Two Wide Outside
- 23" to 21" Row Spacing - One Narrow Inside & Two Wide Outside
- Less than 21" Row Spacing - Wide Outside Plant Boxes Only



1. Remove the long bolt between the uprights by the pocket chain. Do not lose the spacer between the uprights. Remove the outside cotter key in each axle.



2. Install the slotted mounting plates on both sides of the planter using the long bolt just removed. Do not tighten until the plant stand is fully assembled.



3. Slide plant stand onto the packing wheel axle and insert cotter key. Bend cotter key ends to keep in place.

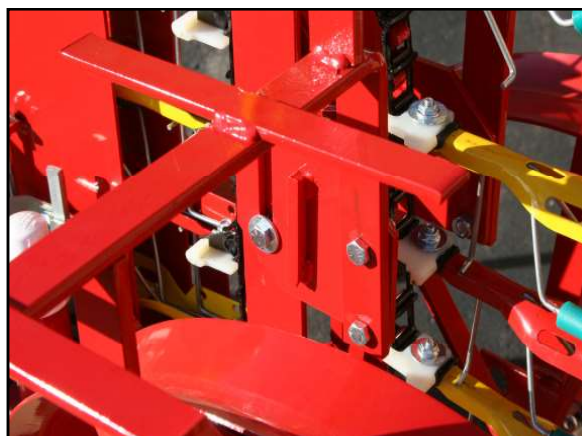

4. Use two 3/8 x 1" hex head bolts and two 3/8" nuts to attach plant stand frame to the slotted mounting bracket.



5. Attach the width adjustment plate with either the inside or outside hole depending on if you are using the wide (standard) plant boxes or the narrow with 3/8 x 1" hex head bolt and nut.

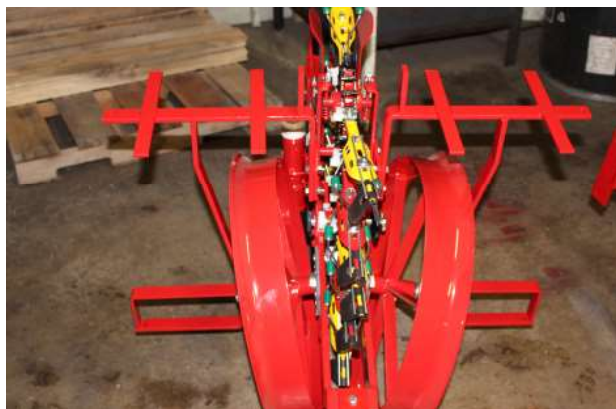

6. Install the plant boxes. These can be adjusted forward or backward for operator comfort.



Assembling the L-Shaped Seat Braces



1. Assemble the L-shaped seat brace by the chain guard. The sea brace mounts on the inside of the frame. The U-bolt mounts from the outside of the transplanter frame under the chain guard. Secure with 1/2" washers and 1/2" hex nuts over each threaded end.



2. The second L-shaped seat brace gets attached on the outside of the transplanter opposite the chain guard. The seat brace mounts on the outside of the frame with the U-bolt coming from the inside of the frame going outside through the seat brace. Secure with 1/2" washers and 1/2" hex nuts over each threaded end.

Mounting your Fiberglass or Cushion Seat

•Fiberglass Seats•



Fiberglass Seat - Turn your fiberglass seat over and remove any covers over the threaded studs. Take your green fiberglass seat bracket and mount it to the bottom of the seat with the side with the bend towards the front of the seat. Secure with four 1/4" hex nuts. Insert the 1/2 x 1-1/2 carriage bolt through the brace and then through the L-shaped seat bracket. Secure with a 1/2" washer and hex nut.

•Cushion Seats•

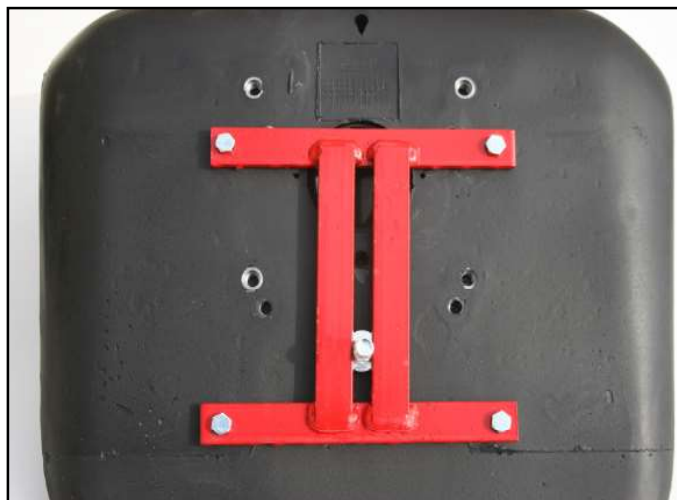

Cushion Seat - Slide the 1/2" x 1-1/2" carriage bolt through the bottom of the red seat bracket before mounting the seat bracket to the seat. After placing the carriage bolt through the seat bracket, place the seat on the L-shaped seat bracket and secure with a 1/2" washer and hex nut.

Loose Pocket Assembly

If your Model 1000 was shipped in a crate, a pocket must be put on the empty attachment link.

The empty attachment link should be right at the top of the chain when the unit is shipped. If it is not, turn the drive wheel until the empty attachment link comes to the top.



Do NOT put #445 rubber gripper onto spring wires(#440) until pocket is assembled to attachment link.

Take the extra V-3 pocket that is wired onto unit and loosen the pocket bolt. Put pocket bolt through the attachment link. Make sure spacing bar stays under the head of the bolt. Place #375 water trip on the back of attachment link, then the 1/4" fender washer. Secure with 1/4" flange nut. After the bolt has been tightened, slide the top part of the #445 rubber gripper to the #440 wire.

Instructions for Direct Drive Clamps

The following instructions are for mounting the direct drive clamps to your Model 1000 unit. Although the pictures show the 2-1/2" clamps, use these instructions for any clamp style. They all mount the same way.



1. Insert a metal bushing from the inside of the frame. Put one of the 1/2 x 1-1/2" bolts through the bushing also from the inside.

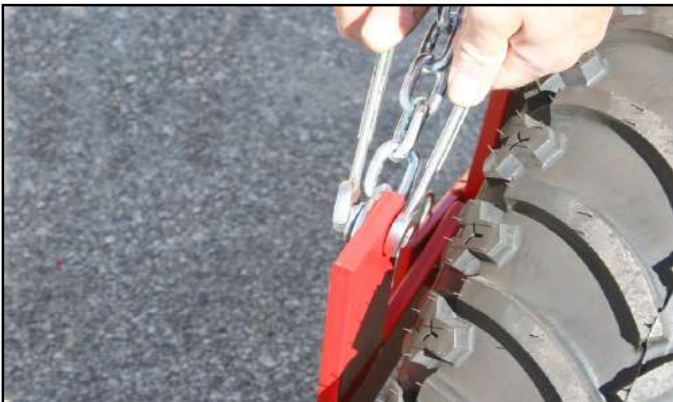

2. Attach the clamp to the bolt in the **top** hole of the bottom set of large holes. Secure with a 1/2" hex nut.
3. If you have a Model 1000B-3 or 1000-2 follow directions below for one clamp side only. To mount safety bar on other clamp side, see page 11. In the **top** set of holes, place a 7/16 x 1-1/4" bolt through the top hole.

4. Slide the end link of the chain onto the bolt.
5. Secure the chain with a 3/8" washer and then a 7/16" hex nut. Make sure the nut is very tight.





6. Use the same instructions for the other side of the Direct Drive Wheel.

Note: The clamps may be reversed or fastened on the inside of the frame for narrow row spacings. Also, if other clamps are in the way, two lefts or two rights may be used. The lower holes on the clamps are for higher toolbars on older models or on tractors where 3-point hitch will not go low enough. Correct height of toolbar is 14" to center.

The Model 1000 unit can now be mounted to your 3-point hitch or toolbar. Following is a list of fasteners that you must use for various toolbars.

Toolbar Hardware List

- 2-1/2" or 2-1/4" Diamond toolbar - 7/8" V-bend U-bolt (2)
- 3" x 3" Flat Toolbar - 3/4" x 5" Hex bolts (4)
- 4" x 4" Flat Toolbar - 3/4" x 6" Hex bolts (4)
- 4" x 7" Toolbar - 3/4" x 9-1/2" Hex bolts (4)
- 5" x 7" Toolbar - 3/4" x 7" Hex bolts (4)
- 7" x 7" Toolbar - 3/4" x 9-1/2" (4)



Shown with clamps reversed

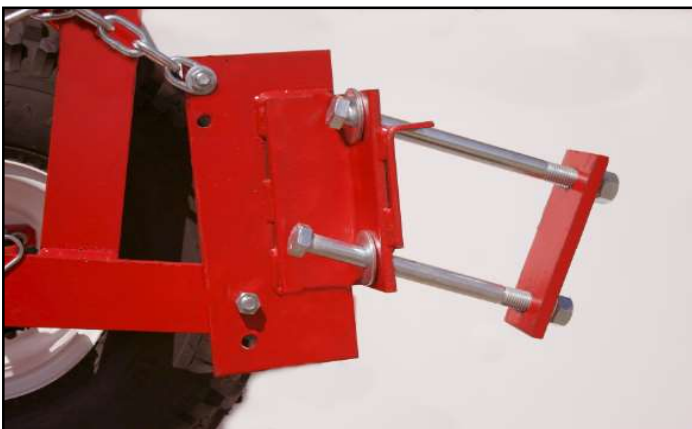

4 x 7 Toolbar Clamp. Use 2-3/4 x 9-1/2" hex bolts, 2-3/4" hex nuts and 2-3/4" washers.

Note: bent bracket on front of clamp

Model 1000B-3 Barrel Mounting & 3-Point Hitch Instructions



For B-3 Model, make sure the safety bar is properly installed!

To mount this safety bar, you must remove the 7/16 x 1-1/4" bolt from on side of the direct drive wheel.

1. Locate the special 2-1/2" stud in your bag of bolts and nuts.
2. Turn a 7/16" hex nut all the way onto the stud.
3. Put the 7/16" washer on the stud next to the nut.
4. Place the lift chain up against the washer.
5. Slide the stud through the hole on the Direct Drive frame and secure with a 7/16" hex nut.
6. Assemble another stud the same way and fasten it to the top hole of the front Direct Drive clamp.
7. Attach the red seat safety bar to the stud on your drive wheel. **The end with the hole must go on the clamp. The slotted end must go on the frame.** After the safety bar is attached, place the small clip pins through the small holes.

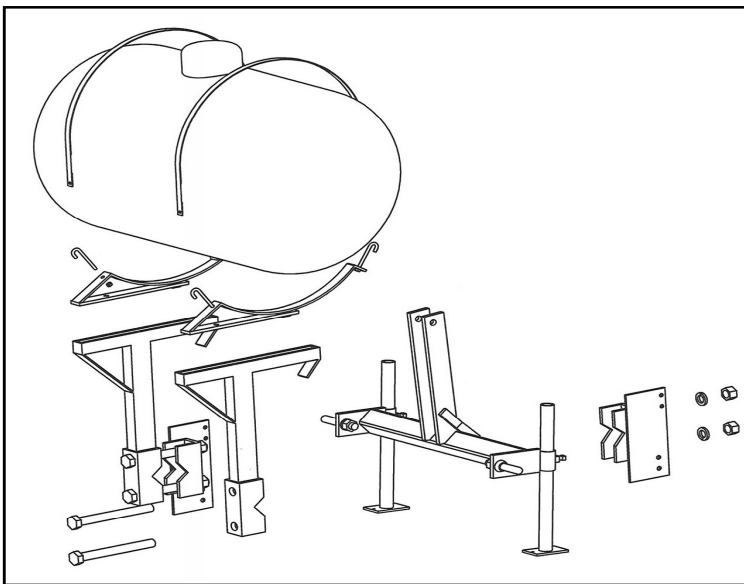

3-Point Hitch & Barrel Mounting

1. On the 3-point hitch, connect the Category I hitch pins through the holes on the outside of the hitch. Put the pins in through the outside and secure with the lock washer and hex nut included with the pin.
2. Slide the green pipe stands up through the pipes on the hitch, then tighten by turning the set screw.

Note: The following instructions will be easier with two people



3. Center the 3-point hitch toolbar with the clamps on your transplanter. Next, line up one of the barrel mounting brackets with the direct drive clamps. Secure using two 1 x 8-1/2 bolts and hex nuts. Do the same with the other barrel mounting bracket.



Side view of B-3 mountings



4. Bolt barrel hoops onto B-3 supports using 1/2 x 3" hex bolt with 1/2" lock nut. Note below: the hoops can be mounted in a forward or back position, depending on clearance that you need for the tractor fenders etc.



5. Screw in the nipple into the bottom of the tank.



6. Insert J-bolts into the four holes on the barrel hoops. It works best to thread 5/16" nut onto J-bolt before hooking up barrel hoops.



7. The 55 gallon poly tank can now be mounted on top of the barrel mountings. Use the four J-bolts and the galvanized straps to secure the barrel to the mountings.

A. Grease all fittings before the start of each day. Grease fittings are found:

1. On each packing wheel axle.
2. Upper pocket chain sprocket (Model 1000 only)
3. Direct drive tire hub (Direct Drive Units only)
4. On each nylon bushing on the pocket chain jackshaft.

B. Regulating Plant Depth

1. All operators should take care to see that the plants are placed well down in the pocket so the plant is held firmly.
2. The plant depth is regulated by the distance the root is extended out of the pocket.
3. To set the plants deeper, simply set the plant in the pocket with the roots further out than what is normally done. (See figure below)
4. If planting strawberries the axle must be raised up, allowing the transplanter unit to go deeper into the soil to cover the strawberry crowns.



V-3 Standard Plant Placement



Deeper Plant Placement

C. Pocket Chain Instructions

1. Make sure that bolts holding the upper sprocket on the pocket chain are not too tight. This will cause unnecessary friction on the unit and possible slippage on packing wheel drive transplanter. Simply loosen the wing nuts if the chain seems too tight.
2. Tighten the wing nuts equally by the top sprocket to keep the chain running level at all times.
3. If in row spacings of 20" or greater are needed, use only 6 pockets. You may remove every other pocket or leave them on. This gives the same speed or greater as a 12 pocket chain.

D. Adjusting or setting the #395R Round Point Shoe

Note: The shoe is preset at the factory for almost all situations.

Follow these instructions only if plants are leaning or in extreme wet or dry soil conditions.

1. Whenever any adjustments are made, be sure to get the shoe directly square and straight in front of the opening of the packing wheels. Make sure that the pockets will run through the middle of the shoe.
2. In loose dry soil, the shoe should be adjusted closer to the packing wheels. This can be done by adjusting the diagonal brace on the shoe.
3. In wet heavy soil, the shoe should be adjusted away from the packing wheels. Again, this can be done by adjusting the diagonal shoe brace.
4. Keep the shoe clean at all times. Do not allow dirt or trash to build up on the front or side of the shoe because this can cause too wide of a furrow that cannot be closed properly by the packing wheels. Poly covered shoes will eliminate this problem.

E. Water Valve Adjustment

1. For more water, make sure the valve is getting a full stroke by adjusting the #604 bracket on the pump rod. Make sure the valve does not over stroke. You should be able to lift the 604 rod 1/4-1/2" at the top of its stroke.
2. A broad range of adjustment can be achieved with the #603 water cam.
3. For wider spacings, the water cam may have to be raised so the water is on the plant. If the #603 is raised, be sure to raise the #604 water adjustment bracket accordingly and do not over stroke.

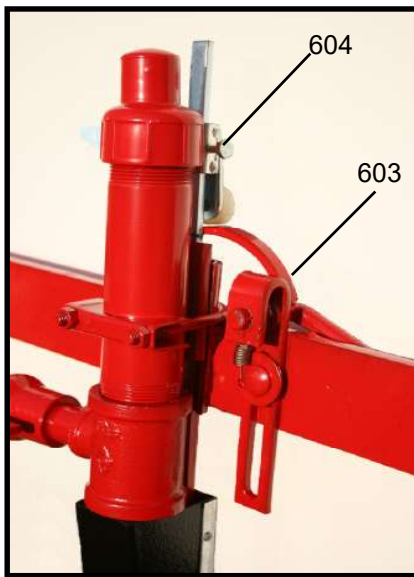

Example: At 20" row spacing, the #603 water cam should be adjusted nearly all the way up the slot. The #604 water adjustment must also be adjusted accordingly so a 1/2" remains on the 604 stroke.

4. Tilting the #603 water cam back towards the water trips on the pockets will create a longer stroke of water or more water before and after the plant.
5. Always empty the water out of the valve after quitting for the day. **Water freezing inside the valve will destroy the #610 and #612 balls inside the valve.**

F. Direct Drive Float Wheel Operation

1. Use only 4 to 5 pounds of air pressure in the Direct Drive Wheel during operation.



Wrong
Toolbar too high



Correct



Wrong
Toolbar too low

2. It is very important when starting to transplant, that the lift chains on the side of the Direct Drive Wheel are loose. See above "Correct" picture.
3. When lowering the transplanting unit into the ground, be sure that the frame members on the Direct Drive Wheel run parallel as is shown in the center picture. This is adjusted by the height of the hitch or toolbar (a pair of gauge wheels will eliminate adjustment of toolbar height).
4. Running the frame parallel will keep the lift chains loose allowing for proper floatation in the Direct Drive Wheel.
5. Running the frame members parallel and level will allow the packing wheels to run in the proper packing position.
6. Running the toolbar too low will tighten the back chains and cause the packing wheels to run too light and not pack the soil properly.
7. Running the toolbar too high will tighten the front lift chains and cause the Direct Drive Wheel to not run on the ground, especially through low spots.

Trouble Shooting

Important - Before attempting any of the following, make sure that the unit is running level or parallel to the ground. Do not run the front hitch or toolbar too far down or up. On all Model 1000 series units, make sure that the chains are loose on both sides of the arch bracket over the drive wheel. For all transplanter, make sure the soil is worked deep enough.

Problem

Solution

Packing wheels not packing properly

- A. Lengthen third arm on tractor to get float in hitch
- B. Hitch is too far down and needs to be lifted (lift chains are not loose)
- C. Clean off sides of shoe
- D. Work soil deeper
- E. Add weight to back of unit
- F. Poly shoes will eliminate soil building up on the outsides

Water leaks from top of water valve

- A. Check to see if the rubber nipple inside the top of the valve is in place and rounded.
- B. #610 ball inside the valve has collapsed and needs to be replaced.

Water leaks from bottom of water valve

- A. Rubber ball #612 on pin is broke and needs to be replaced
- B. The nylon nut on the bottom is broken and needs to be replaced

Water not uniform

- A. Make sure all the water trips on the pockets are in good shape and at even distances from the attachment link.
- B. Check to see that all springs on the water valve are in good working order.
- C. Water valve has dirt or residue build up that needs to be cleaned out

Water misses plants

•See water valve instructions on Page13.

Plants falling out of pocket

- A. Inspect the rubber grippers to make sure that they are not all stretched out.
- B. Tighten the L-bolts on the side of the guides.
- C. #482 pocket extensions may be needed if planting cell-type plants.
- D. Check bottom of guides to insure that the pocket is not releasing the plant too soon.

Plants on top of soil

- A. Cut back on water because the plants are floating up out of the shoe.
- B. Plants need to be pulled further out of the pocket to put them deeper.
- C. Too much loose soil is getting inside the shoe before the packing wheels can pack. Move shoe closer to packing wheels.
- D. A gap might be occurring by having the hitch too low causing the packing wheels to be up in the air or not being able to put enough pressure on the soil.
- E. Ground not worked deep enough causing the shoe to not go deep enough into the soil.

Plants leaning

- A. Need to put plant further in the pocket to keep it from hitting the bottom of the furrow.
- B. Possibility of needing a deeper shoe.
- C. May need #482 extensions to help support the cell of a plant coming from a tray.
- D. See Operating Instructions on Page 13 about adjusting the shoe.

Safety Precautions

1. Make sure tractor is stopped and in neutral with the transplanter lowered to the ground before getting on and off the unit.
2. No operator is allowed to be on the unit as it is raised and lowered.
3. No operator is allowed on the transplanter as it is transported to or from the field.
4. All operators must be seated before movement begins and remain seated until the transplanter is completely stopped.
5. Never leave the transplanter in the raised position.
6. Keep all shields and guards in place when operating the transplanter.
7. Never attempt repairs or maintenance while the transplanter is in motion.
8. Never put the tractor in reverse while the transplanter is on the ground.
9. Follow all safety instructions supplied by the tractor manufacturer to which the transplanter is mounted.

MACHINE IMPROVEMENTS

MECHANICAL TRANSPLANTER CO. IS ALWAYS STRIVING TO MAKE IMPROVEMENTS ON THEIR LINE OF EQUIPMENT. MECHANICAL TRANSPLANTER CO. RESERVES THE RIGHT TO MAKE IMPROVEMENTS AND CHANGES AT ANY TIME WITHOUT INCURRING OBLIGATIONS TO MAKE SUCH CHANGES OR ADDITIONS TO EQUIPMENT PREVIOUSLY SOLD.

Limited Warranty

Mechanical Transplanter Company warrants each item of new equipment manufactured by Mechanical to be free from defects in material and workmanship under normal use and service.

The obligation of Mechanical Transplanter Company under this LIMITED WARRANTY is limited to repairing or replacing as Mechanical may elect, and any parts that prove, in Mechanical's judgment, to be defective in material and workmanship within the first season's use or 45 consecutive days after initially placing equipment in operation, whichever occurs first. Any outside work or alterations without Mechanical's written approval will render the LIMITED WARRANTY void.

Mechanical's obligation specifically excludes any liability for consequential damages, such as loss of profits, delays, expenses, damage to goods or property used in connection with or processed in or by the product sold, or damage to the product sold from whatsoever cause, whether or not such loss is due to negligence of selling dealer of Mechanical Transplanter Company.

This limited warranty shall not apply to any item or machine which shall have been operated in a manner not recommended by the Company nor which shall have been repaired, altered, misused, damaged in an accident, neglected, tampered with or used in any way which in the Company's opinion adversely affects its performance and results.

No person is authorized to give any other warranties or to assume any other liability on behalf of Mechanical Transplanter Company, unless made in writing by Mechanical.

This limited warranty covers repair or replacement of Mechanical Transplanter Co. equipment only and does not cover crop loss, downtime, labor, damage to other equipment, etc.

This limited warranty does not apply to exterior finishes, tires, chain links, bearings, or any other items sold by Mechanical Transplanter Co., but warranted by the original manufacturer except to the extent of their individual manufacturer's warranty.

THIS LIMITED WARRANTY IS IN LIEU OF ALL OTHER WARRANTIES, EXPRESSED OR IMPLIED. WARRANTIES OF MERCHANTABILITY AND FITNESS FOR PARTICULAR PURPOSE ARE EXCLUDED, AS ARE ALL OTHER REPRESENTATIONS TO THE USER-PURCHASER, AND ALL OTHER OBLIGATIONS OR LIABILITIES, INCLUDING LIABILITY FOR INCIDENTAL AND CONSEQUENTIAL DAMAGES, ON THE PART OF MECHANICAL OR THE SELLER.

Mechanical Transplanter Co.

Model 1000 and 1000B-3

Operators Manual



Mechanical Transplanter Co., LLC
1150 Central Avenue • Holland, MI 49423-5230
Phone: 616-396-8738 • Fax: 616-396-3619
website: www.mechanicaltransplanter.com
e-mail: mtc@mechanicaltransplanter.com

Spacing Charts and Information

| SPACING CHART FOR DIRECT DRIVE UNIT W/ 12 POCKET CHAIN | | | | | | |
|---|---------------------------------|-------------------------------------|-----------------------|-----------------------|-------------------|-----------------|
| Sprocket on OUT-SIDE of Jackshaft | Sprocket on INSIDE of Jackshaft | Number of Teeth on Sprocket on Unit | | | | |
| | | 7 | 8 | 9 | 10 | 11 |
| 7 | 11 | 6" 15.2cm | 6-1/2" - 7" 17.8cm | 7-1/2" - 8" 20.3cm | 8-1/2" 21.6cm | 9" 22.8cm |
| 7 | 7 | 9" 22.8cm | 10-1/2" 26.7cm | 13" 33cm | 15" 38.1cm | 16" 40.6cm |
| 8 | 7 | 10-1/2" 26.7cm | 12-1/2" 31.7cm | 14" 35.5cm | 15" 38.1cm | 16" 40.6cm |
| 9 | 7 | 12" 30.5cm | 13-1/2" 34.3cm | 15" 38.1cm | 17" 43.2cm | 18-1/2" 47cm |
| 10 | 7 | 13" 33cm | 14" 35.5cm | 15-1/2" 39.4cm | 17-1/2" 44.5cm | 20-1/2" 52cm |
| 11 | 7 | 15" 38.1cm | 18" 45.7cm | | | |

Double any of the above spacings by using every other pocket (6 pocket).
Make sure HITCH and UNIT are level or parallel to the ground when planting.

Use for Model 1000

| DISC SPACING CHART FOR MODELS W/ DIRECT DRIVE | | | | | | | |
|--|---------------------------------|-------------------------------|-------------------------------------|--------|--------|--------|--------|
| Sprocket on OUTSIDE of Jackshaft | Sprocket on INSIDE of Jackshaft | Number of Pockets on the Disc | Number of Teeth on Sprocket by Disc | | | | |
| | | | 7 | 8 | 9 | 10 | 11 |
| 7 | 7 | 24 | | 2" | 2-1/4" | 2-1/2" | 2-3/4" |
| | | 16 | 3" | 3-1/4" | 3-1/2" | 4" | 4-1/2" |
| | | 12 | | 4-3/4" | 5-1/4" | 5-3/4" | 6-1/4" |
| 8 | 7 | 24 | | 2-1/2" | 3" | 3-1/4" | 3-1/2" |
| | | 16 | 3-1/2" | 3-3/4" | 4-1/4" | 4-1/2" | 5-1/4" |
| | | 12 | | 6" | 6-1/4" | 6-3/4" | 7" |
| 9 | 7 | 24 | 2-1/2" | 2-3/4" | 3-1/4" | 3-1/2" | 4" |
| | | 16 | 3-3/4" | 4-1/4" | 4-1/2" | 5" | 5-1/2" |
| | | 12 | 4-1/2" | 6-1/4" | 6-1/2" | 7-1/4" | 8" |
| 10 | 7 | 24 | 2-1/2" | 3" | 3-1/2" | 3-3/4" | 4-1/2" |
| | | 16 | 3-3/4" | 4-1/2" | 5-1/4" | | |
| | | 12 | 5-1/4" | 6" | 7" | 7-1/2" | 8-1/2" |
| 11 | 7 | 24 | 2-1/2" | 3" | 3-1/2" | 4-1/4" | 4-3/4" |
| | | 16 | 4" | 5" | 6" | | |
| | | 12 | 5-1/2" | 6-1/2" | 7-1/2" | 9" | 10" |

Use for Model 1000 with disc mounted pockets

Assembly Instructions

For Model 1000 Series Transplanters

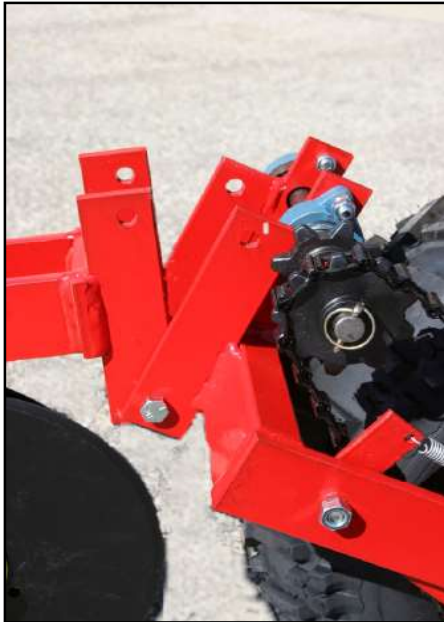

1. Bolt on the Direct Drive Float Wheel using the four 1/2 x 1-1/2 " bolts. Secure using the 1/2" hex nuts.



2. Remove the following parts from the direct drive wheel jackshaft: Clip pin, drive chain coming from the wheel, outside sprocket on jackshaft, and pipe spacer. Then remove the extra top hex nut located on the flange bearing.



3. Install the inside chain guard of the unit. Fasten front short tab to the top bolt on flange bearing from #2 photo with hex nut. The long tab attaches to the empty hole on the transplanter frame by the packing wheels. The guard must fit between the shoe brace and the guide adjustment bolt. Use the 3/8 x 1" bolt and a 3/8" hex nut to secure.

4. Select the proper sprocket arrangement for the spacing needed between plants. Look on page 2 or the chart on the side of your transplanter for the correct arrangement. For spacings using 11 tooth sprockets, extra chain links may be needed to lengthen the drive chain. These links are wired to the lift chain by the drive wheel. After finding the correct sprockets, run the long drive chain from the sprocket on the pocket chain shaft to the inside sprocket on the jackshaft of the direct drive wheel. The chain must go over the idler sprocket on the shoe brace and under the chain tightener sprocket as shown in the photo below.



5. Slide the red pipe spacer back onto the jackshaft. Insert the roll pin back into the second hole from the outside of the jackshaft. Slide the outside sprocket over the roll pin. Slide the drive chain coming from the drive wheel over the outside jackshaft sprocket. You may have to use your hand to push the chain tightener up to create enough slack in the chain. Insert the clip pin into the outside hole of the jackshaft.



6. Slide the outside chain guard onto the two pins and secure with clip pins.

Installation of Plant Stands

It is very important to know what row width will be used before installing the plant stands on multi-row transplanter. Follow the chart below.

- 42" Row Spacing - All Wide Plant Boxes
- 41" to 36" Row Spacing - Narrow Plant Boxes Inside
- 35" to 24" Row Spacing - One Wide Inside & Two Wide Outside
- 23" to 21" Row Spacing - One Narrow Inside & Two Wide Outside
- Less than 21" Row Spacing - Wide Outside Plant Boxes Only



1. Remove the long bolt between the uprights by the pocket chain. Do not lose the spacer between the uprights. Remove the outside cotter key in each axle.



2. Install the slotted mounting plates on both sides of the planter using the long bolt just removed. Do not tighten until the plant stand is fully assembled.



3. Slide plant stand onto the packing wheel axle and insert cotter key. Bend cotter key ends to keep in place.

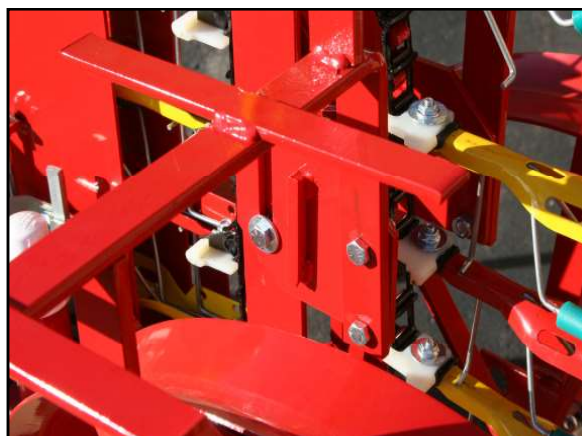

4. Use two 3/8 x 1" hex head bolts and two 3/8" nuts to attach plant stand frame to the slotted mounting bracket.



5. Attach the width adjustment plate with either the inside or outside hole depending on if you are using the wide (standard) plant boxes or the narrow with 3/8 x 1" hex head bolt and nut.

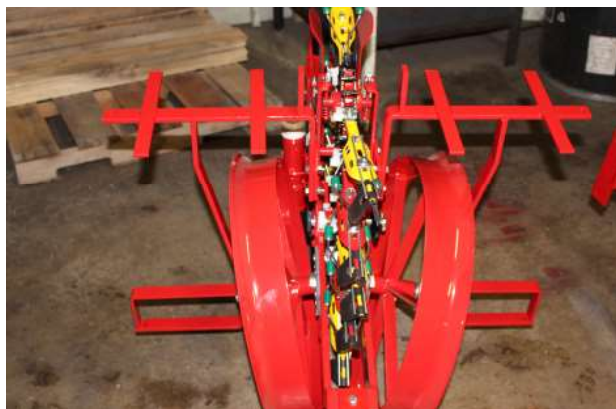

6. Install the plant boxes. These can be adjusted forward or backward for operator comfort.



Assembling the L-Shaped Seat Braces



1. Assemble the L-shaped seat brace by the chain guard. The sea brace mounts on the inside of the frame. The U-bolt mounts from the outside of the transplanter frame under the chain guard. Secure with 1/2" washers and 1/2" hex nuts over each threaded end.



2. The second L-shaped seat brace gets attached on the outside of the transplanter opposite the chain guard. The seat brace mounts on the outside of the frame with the U-bolt coming from the inside of the frame going outside through the seat brace. Secure with 1/2" washers and 1/2" hex nuts over each threaded end.

Mounting your Fiberglass or Cushion Seat

•Fiberglass Seats•



Fiberglass Seat - Turn your fiberglass seat over and remove any covers over the threaded studs. Take your green fiberglass seat bracket and mount it to the bottom of the seat with the side with the bend towards the front of the seat. Secure with four 1/4" hex nuts. Insert the 1/2 x 1-1/2 carriage bolt through the brace and then through the L-shaped seat bracket. Secure with a 1/2" washer and hex nut.

•Cushion Seats•

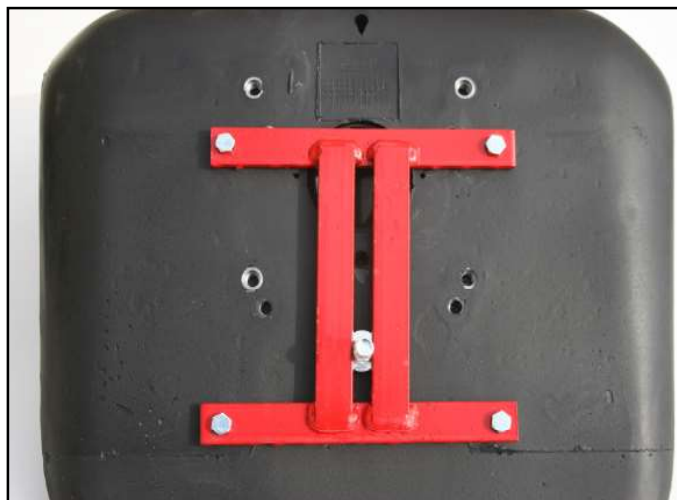

Cushion Seat - Slide the 1/2" x 1-1/2" carriage bolt through the bottom of the red seat bracket before mounting the seat bracket to the seat. After placing the carriage bolt through the seat bracket, place the seat bracket on the cushion seat. Secure with four 5/16" x 1" hex head bolts. Place the seat on the L-shaped seat bracket and secure with a 1/2" washer and hex nut.

Loose Pocket Assembly

If your Model 1000 was shipped in a crate, a pocket must be put on the empty attachment link.

The empty attachment link should be right at the top of the chain when the unit is shipped. If it is not, turn the drive wheel until the empty attachment link comes to the top.



Do NOT put #445 rubber gripper onto spring wires(#440) until pocket is assembled to attachment link.

Take the extra V-3 pocket that is wired onto unit and loosen the pocket bolt. Put pocket bolt through the attachment link. Make sure spacing bar stays under the head of the bolt. Place #375 water trip on the back of attachment link, then the 1/4" fender washer. Secure with 1/4" flange nut. After the bolt has been tightened, slide the top part of the #445 rubber gripper to the #440 wire.

Instructions for Direct Drive Clamps

The following instructions are for mounting the direct drive clamps to your Model 1000 unit. Although the pictures show the 2-1/2" clamps, use these instructions for any clamp style. They all mount the same way.



1. Insert a metal bushing from the inside of the frame. Put one of the 1/2 x 1-1/2" bolts through the bushing also from the inside.

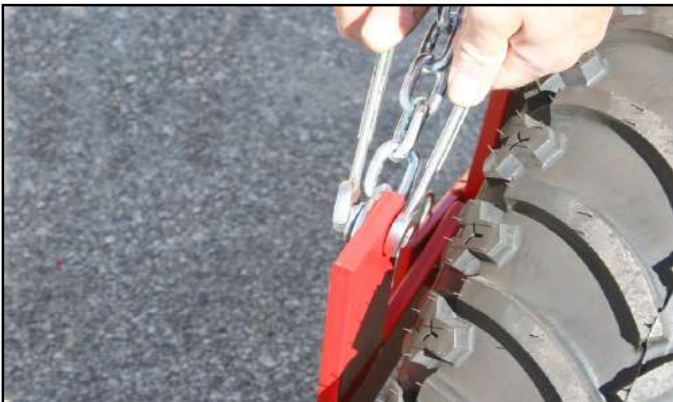

2. Attach the clamp to the bolt in the **top** hole of the bottom set of large holes. Secure with a 1/2" hex nut.
3. If you have a Model 1000B-3 or 1000-2 follow directions below for one clamp side only. To mount safety bar on other clamp side, see page 11. In the **top** set of holes, place a 7/16 x 1-1/4" bolt through the top hole.

4. Slide the end link of the chain onto the bolt.
5. Secure the chain with a 3/8" washer and then a 7/16" hex nut. Make sure the nut is very tight.





6. Use the same instructions for the other side of the Direct Drive Wheel.

Note: The clamps may be reversed or fastened on the inside of the frame for narrow row spacings. Also, if other clamps are in the way, two lefts or two rights may be used. The lower holes on the clamps are for higher toolbars on older models or on tractors where 3-point hitch will not go low enough. Correct height of toolbar is 14" to center.

The Model 1000 unit can now be mounted to your 3-point hitch or toolbar. Following is a list of fasteners that you must use for various toolbars.

Toolbar Hardware List

- 2-1/2" or 2-1/4" Diamond toolbar - 7/8" V-bend U-bolt (2)
- 3" x 3" Flat Toolbar - 3/4" x 5" Hex bolts (4)
- 4" x 4" Flat Toolbar - 3/4" x 6" Hex bolts (4)
- 4" x 7" Toolbar - 3/4" x 9-1/2" Hex bolts (4)
- 5" x 7" Toolbar - 3/4" x 7" Hex bolts (4)
- 7" x 7" Toolbar - 3/4" x 9-1/2" (4)



Shown with clamps reversed

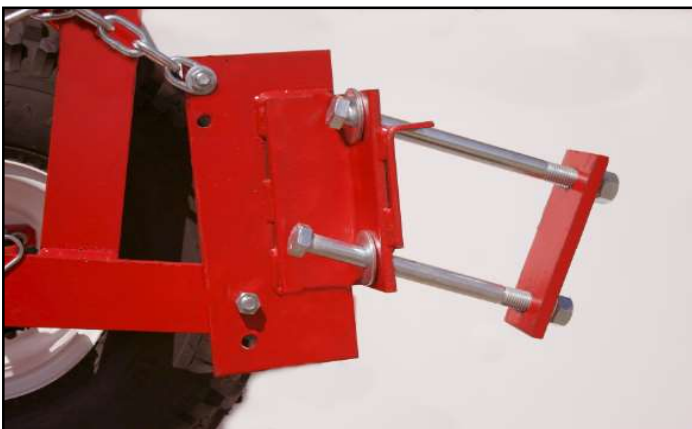

4 x 7 Toolbar Clamp. Use 2-3/4 x 9-1/2" hex bolts, 2-3/4" hex nuts and 2-3/4" washers.

Note: bent bracket on front of clamp

Model 1000B-3 Barrel Mounting & 3-Point Hitch Instructions



For B-3 Model, make sure the safety bar is properly installed!

To mount this safety bar, you must remove the 7/16 x 1-1/4" bolt from on side of the direct drive wheel.

1. Locate the special 2-1/2" stud in your bag of bolts and nuts.
2. Turn a 7/16" hex nut all the way onto the stud.
3. Put the 7/16" washer on the stud next to the nut.
4. Place the lift chain up against the washer.
5. Slide the stud through the hole on the Direct Drive frame and secure with a 7/16" hex nut.
6. Assemble another stud the same way and fasten it to the top hole of the front Direct Drive clamp.
7. Attach the red seat safety bar to the stud on your drive wheel. **The end with the hole must go on the clamp. The slotted end must go on the frame.** After the safety bar is attached, place the small clip pins through the small holes.

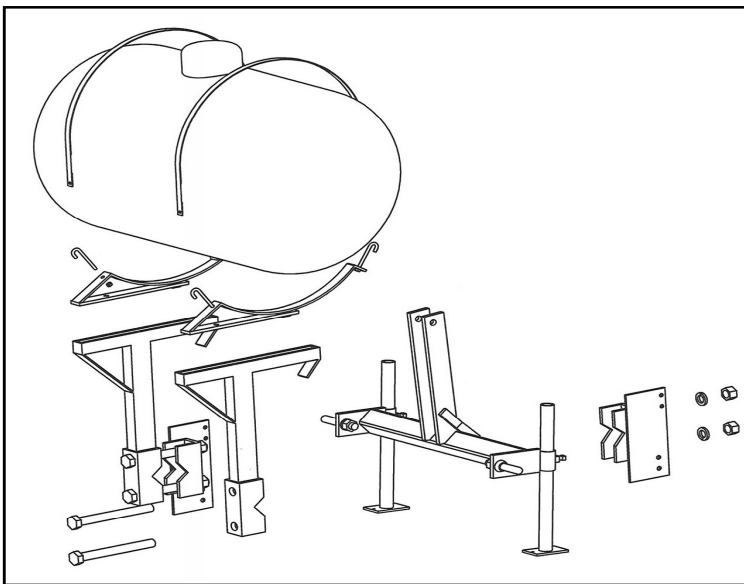

3-Point Hitch & Barrel Mounting

1. On the 3-point hitch, connect the Category I hitch pins through the holes on the outside of the hitch. Put the pins in through the outside and secure with the lock washer and hex nut included with the pin.
2. Slide the green pipe stands up through the pipes on the hitch, then tighten by turning the set screw.

Note: The following instructions will be easier with two people



3. Center the 3-point hitch toolbar with the clamps on your transplanter. Next, line up one of the barrel mounting brackets with the direct drive clamps. Secure using two 1 x 8-1/2 bolts and hex nuts. Do the same with the other barrel mounting bracket.



Side view of B-3 mountings



4. Bolt barrel hoops onto B-3 supports using 1/2 x 3" hex bolt with 1/2" lock nut. Note below: the hoops can be mounted in a forward or back position, depending on clearance that you need for the tractor fenders etc.



5. Screw in the nipple into the bottom of the tank.



6. Insert J-bolts into the four holes on the barrel hoops. It works best to thread 5/16" nut onto J-bolt before hooking up barrel hoops.



7. The 55 gallon poly tank can now be mounted on top of the barrel mountings. Use the four J-bolts and the galvanized straps to secure the barrel to the mountings.

A. Grease all fittings before the start of each day. Grease fittings are found:

1. On each packing wheel axle.
2. Upper pocket chain sprocket (Model 1000 only)
3. Direct drive tire hub (Direct Drive Units only)
4. On each nylon bushing on the pocket chain jackshaft.

B. Regulating Plant Depth

1. All operators should take care to see that the plants are placed well down in the pocket so the plant is held firmly.
2. The plant depth is regulated by the distance the root is extended out of the pocket.
3. To set the plants deeper, simply set the plant in the pocket with the roots further out than what is normally done. (See figure below)
4. If planting strawberries the axle must be raised up, allowing the transplanter unit to go deeper into the soil to cover the strawberry crowns.



V-3 Standard Plant Placement



Deeper Plant Placement

C. Pocket Chain Instructions

1. Make sure that bolts holding the upper sprocket on the pocket chain are not too tight. This will cause unnecessary friction on the unit and possible slippage on packing wheel drive transplanter. Simply loosen the wing nuts if the chain seems too tight.
2. Tighten the wing nuts equally by the top sprocket to keep the chain running level at all times.
3. If in row spacings of 20" or greater are needed, use only 6 pockets. You may remove every other pocket or leave them on. This gives the same speed or greater as a 12 pocket chain.

D. Adjusting or setting the #395R Round Point Shoe

Note: The shoe is preset at the factory for almost all situations.

Follow these instructions only if plants are leaning or in extreme wet or dry soil conditions.

1. Whenever any adjustments are made, be sure to get the shoe directly square and straight in front of the opening of the packing wheels. Make sure that the pockets will run through the middle of the shoe.
2. In loose dry soil, the shoe should be adjusted closer to the packing wheels. This can be done by adjusting the diagonal brace on the shoe.
3. In wet heavy soil, the shoe should be adjusted away from the packing wheels. Again, this can be done by adjusting the diagonal shoe brace.
4. Keep the shoe clean at all times. Do not allow dirt or trash to build up on the front or side of the shoe because this can cause too wide of a furrow that cannot be closed properly by the packing wheels. Poly covered shoes will eliminate this problem.

E. Water Valve Adjustment

1. For more water, make sure the valve is getting a full stroke by adjusting the #604 bracket on the pump rod. Make sure the valve does not over stroke. You should be able to lift the 604 rod 1/4-1/2" at the top of its stroke.
2. A broad range of adjustment can be achieved with the #603 water cam.
3. For wider spacings, the water cam may have to be raised so the water is on the plant. If the #603 is raised, be sure to raise the #604 water adjustment bracket accordingly and do not over stroke.

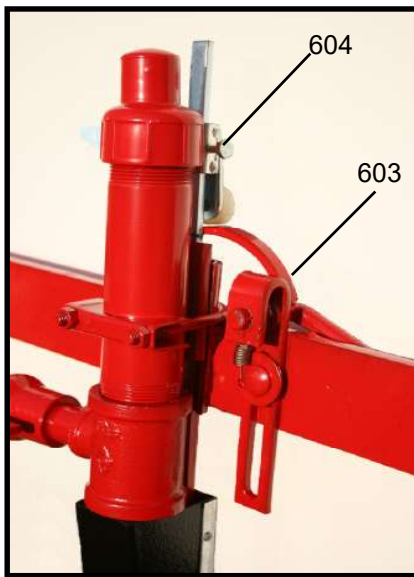

Example: At 20" row spacing, the #603 water cam should be adjusted nearly all the way up the slot. The #604 water adjustment must also be adjusted accordingly so a 1/2" remains on the 604 stroke.

4. Tilting the #603 water cam back towards the water trips on the pockets will create a longer stroke of water or more water before and after the plant.
5. Always empty the water out of the valve after quitting for the day. **Water freezing inside the valve will destroy the #610 and #612 balls inside the valve.**

F. Direct Drive Float Wheel Operation

1. Use only 4 to 5 pounds of air pressure in the Direct Drive Wheel during operation.



Wrong
Toolbar too high



Correct



Wrong
Toolbar too low

2. It is very important when starting to transplant, that the lift chains on the side of the Direct Drive Wheel are loose. See above "Correct" picture.
3. When lowering the transplanting unit into the ground, be sure that the frame members on the Direct Drive Wheel run parallel as is shown in the center picture. This is adjusted by the height of the hitch or toolbar (a pair of gauge wheels will eliminate adjustment of toolbar height).
4. Running the frame parallel will keep the lift chains loose allowing for proper floatation in the Direct Drive Wheel.
5. Running the frame members parallel and level will allow the packing wheels to run in the proper packing position.
6. Running the toolbar too low will tighten the back chains and cause the packing wheels to run too light and not pack the soil properly.
7. Running the toolbar too high will tighten the front lift chains and cause the Direct Drive Wheel to not run on the ground, especially through low spots.

Trouble Shooting

Important - Before attempting any of the following, make sure that the unit is running level or parallel to the ground. Do not run the front hitch or toolbar too far down or up. On all Model 1000 series units, make sure that the chains are loose on both sides of the arch bracket over the drive wheel. For all transplanter, make sure the soil is worked deep enough.

Problem

Solution

Packing wheels not packing properly

- A. Lengthen third arm on tractor to get float in hitch
- B. Hitch is too far down and needs to be lifted (lift chains are not loose)
- C. Clean off sides of shoe
- D. Work soil deeper
- E. Add weight to back of unit
- F. Poly shoes will eliminate soil building up on the outsides

Water leaks from top of water valve

- A. Check to see if the rubber nipple inside the top of the valve is in place and rounded.
- B. #610 ball inside the valve has collapsed and needs to be replaced.

Water leaks from bottom of water valve

- A. Rubber ball #612 on pin is broke and needs to be replaced
- B. The nylon nut on the bottom is broken and needs to be replaced

Water not uniform

- A. Make sure all the water trips on the pockets are in good shape and at even distances from the attachment link.
- B. Check to see that all springs on the water valve are in good working order.
- C. Water valve has dirt or residue build up that needs to be cleaned out

Water misses plants

•See water valve instructions on Page13.

Plants falling out of pocket

- A. Inspect the rubber grippers to make sure that they are not all stretched out.
- B. Tighten the L-bolts on the side of the guides.
- C. #482 pocket extensions may be needed if planting cell-type plants.
- D. Check bottom of guides to insure that the pocket is not releasing the plant too soon.

Plants on top of soil

- A. Cut back on water because the plants are floating up out of the shoe.
- B. Plants need to be pulled further out of the pocket to put them deeper.
- C. Too much loose soil is getting inside the shoe before the packing wheels can pack. Move shoe closer to packing wheels.
- D. A gap might be occurring by having the hitch too low causing the packing wheels to be up in the air or not being able to put enough pressure on the soil.
- E. Ground not worked deep enough causing the shoe to not go deep enough into the soil.

Plants leaning

- A. Need to put plant further in the pocket to keep it from hitting the bottom of the furrow.
- B. Possibility of needing a deeper shoe.
- C. May need #482 extensions to help support the cell of a plant coming from a tray.
- D. See Operating Instructions on Page 13 about adjusting the shoe.

Safety Precautions

1. Make sure tractor is stopped and in neutral with the transplanter lowered to the ground before getting on and off the unit.
2. No operator is allowed to be on the unit as it is raised and lowered.
3. No operator is allowed on the transplanter as it is transported to or from the field.
4. All operators must be seated before movement begins and remain seated until the transplanter is completely stopped.
5. Never leave the transplanter in the raised position.
6. Keep all shields and guards in place when operating the transplanter.
7. Never attempt repairs or maintenance while the transplanter is in motion.
8. Never put the tractor in reverse while the transplanter is on the ground.
9. Follow all safety instructions supplied by the tractor manufacturer to which the transplanter is mounted.

MACHINE IMPROVEMENTS

MECHANICAL TRANSPLANTER CO. IS ALWAYS STRIVING TO MAKE IMPROVEMENTS ON THEIR LINE OF EQUIPMENT. MECHANICAL TRANSPLANTER CO. RESERVES THE RIGHT TO MAKE IMPROVEMENTS AND CHANGES AT ANY TIME WITHOUT INCURRING OBLIGATIONS TO MAKE SUCH CHANGES OR ADDITIONS TO EQUIPMENT PREVIOUSLY SOLD.

Limited Warranty

Mechanical Transplanter Company warrants each item of new equipment manufactured by Mechanical to be free from defects in material and workmanship under normal use and service.

The obligation of Mechanical Transplanter Company under this LIMITED WARRANTY is limited to repairing or replacing as Mechanical may elect, and any parts that prove, in Mechanical's judgment, to be defective in material and workmanship within the first season's use or 45 consecutive days after initially placing equipment in operation, whichever occurs first. Any outside work or alterations without Mechanical's written approval will render the LIMITED WARRANTY void.

Mechanical's obligation specifically excludes any liability for consequential damages, such as loss of profits, delays, expenses, damage to goods or property used in connection with or processed in or by the product sold, or damage to the product sold from whatsoever cause, whether or not such loss is due to negligence of selling dealer of Mechanical Transplanter Company.

This limited warranty shall not apply to any item or machine which shall have been operated in a manner not recommended by the Company nor which shall have been repaired, altered, misused, damaged in an accident, neglected, tampered with or used in any way which in the Company's opinion adversely affects its performance and results.

No person is authorized to give any other warranties or to assume any other liability on behalf of Mechanical Transplanter Company, unless made in writing by Mechanical.

This limited warranty covers repair or replacement of Mechanical Transplanter Co. equipment only and does not cover crop loss, downtime, labor, damage to other equipment, etc.

This limited warranty does not apply to exterior finishes, tires, chain links, bearings, or any other items sold by Mechanical Transplanter Co., but warranted by the original manufacturer except to the extent of their individual manufacturer's warranty.

THIS LIMITED WARRANTY IS IN LIEU OF ALL OTHER WARRANTIES, EXPRESSED OR IMPLIED. WARRANTIES OF MERCHANTABILITY AND FITNESS FOR PARTICULAR PURPOSE ARE EXCLUDED, AS ARE ALL OTHER REPRESENTATIONS TO THE USER-PURCHASER, AND ALL OTHER OBLIGATIONS OR LIABILITIES, INCLUDING LIABILITY FOR INCIDENTAL AND CONSEQUENTIAL DAMAGES, ON THE PART OF MECHANICAL OR THE SELLER.

Mechanical Transplanter Co.

Model 1000 and 1000B-3

Operators Manual



Mechanical Transplanter Co., LLC
1150 Central Avenue • Holland, MI 49423-5230
Phone: 616-396-8738 • Fax: 616-396-3619
website: www.mechanicaltransplanter.com
e-mail: mtc@mechanicaltransplanter.com

Spacing Charts and Information

| SPACING CHART FOR DIRECT DRIVE UNIT W/ 12 POCKET CHAIN | | | | | | |
|---|---------------------------------|-------------------------------------|-----------------------|-----------------------|-------------------|-----------------|
| Sprocket on OUT-SIDE of Jackshaft | Sprocket on INSIDE of Jackshaft | Number of Teeth on Sprocket on Unit | | | | |
| | | 7 | 8 | 9 | 10 | 11 |
| 7 | 11 | 6" 15.2cm | 6-1/2" - 7" 17.8cm | 7-1/2" - 8" 20.3cm | 8-1/2" 21.6cm | 9" 22.8cm |
| 7 | 7 | 9" 22.8cm | 10-1/2" 26.7cm | 13" 33cm | 15" 38.1cm | 16" 40.6cm |
| 8 | 7 | 10-1/2" 26.7cm | 12-1/2" 31.7cm | 14" 35.5cm | 15" 38.1cm | 16" 40.6cm |
| 9 | 7 | 12" 30.5cm | 13-1/2" 34.3cm | 15" 38.1cm | 17" 43.2cm | 18-1/2" 47cm |
| 10 | 7 | 13" 33cm | 14" 35.5cm | 15-1/2" 39.4cm | 17-1/2" 44.5cm | 20-1/2" 52cm |
| 11 | 7 | 15" 38.1cm | 18" 45.7cm | | | |

Double any of the above spacings by using every other pocket (6 pocket).
Make sure HITCH and UNIT are level or parallel to the ground when planting.

Use for Model 1000

| DISC SPACING CHART FOR MODELS W/ DIRECT DRIVE | | | | | | | |
|--|---------------------------------|-------------------------------|-------------------------------------|--------|--------|--------|--------|
| Sprocket on OUTSIDE of Jackshaft | Sprocket on INSIDE of Jackshaft | Number of Pockets on the Disc | Number of Teeth on Sprocket by Disc | | | | |
| | | | 7 | 8 | 9 | 10 | 11 |
| 7 | 7 | 24 | | 2" | 2-1/4" | 2-1/2" | 2-3/4" |
| | | 16 | 3" | 3-1/4" | 3-1/2" | 4" | 4-1/2" |
| | | 12 | | 4-3/4" | 5-1/4" | 5-3/4" | 6-1/4" |
| 8 | 7 | 24 | | 2-1/2" | 3" | 3-1/4" | 3-1/2" |
| | | 16 | 3-1/2" | 3-3/4" | 4-1/4" | 4-1/2" | 5-1/4" |
| | | 12 | | 6" | 6-1/4" | 6-3/4" | 7" |
| 9 | 7 | 24 | 2-1/2" | 2-3/4" | 3-1/4" | 3-1/2" | 4" |
| | | 16 | 3-3/4" | 4-1/4" | 4-1/2" | 5" | 5-1/2" |
| | | 12 | 4-1/2" | 6-1/4" | 6-1/2" | 7-1/4" | 8" |
| 10 | 7 | 24 | 2-1/2" | 3" | 3-1/2" | 3-3/4" | 4-1/2" |
| | | 16 | 3-3/4" | 4-1/2" | 5-1/4" | | |
| | | 12 | 5-1/4" | 6" | 7" | 7-1/2" | 8-1/2" |
| 11 | 7 | 24 | 2-1/2" | 3" | 3-1/2" | 4-1/4" | 4-3/4" |
| | | 16 | 4" | 5" | 6" | | |
| | | 12 | 5-1/2" | 6-1/2" | 7-1/2" | 9" | 10" |

Use for Model 1000 with disc mounted pockets

Assembly Instructions

For Model 1000 Series Transplanters

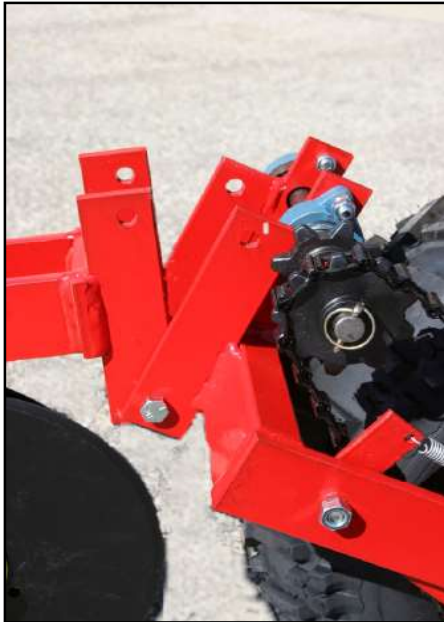

1. Bolt on the Direct Drive Float Wheel using the four 1/2 x 1-1/2 " bolts. Secure using the 1/2" hex nuts.



2. Remove the following parts from the direct drive wheel jackshaft: Clip pin, drive chain coming from the wheel, outside sprocket on jackshaft, and pipe spacer. Then remove the extra top hex nut located on the flange bearing.



3. Install the inside chain guard of the unit. Fasten front short tab to the top bolt on flange bearing from #2 photo with hex nut. The long tab attaches to the empty hole on the transplanter frame by the packing wheels. The guard must fit between the shoe brace and the guide adjustment bolt. Use the 3/8 x 1" bolt and a 3/8" hex nut to secure.

4. Select the proper sprocket arrangement for the spacing needed between plants. Look on page 2 or the chart on the side of your transplanter for the correct arrangement. For spacings using 11 tooth sprockets, extra chain links may be needed to lengthen the drive chain. These links are wired to the lift chain by the drive wheel. After finding the correct sprockets, run the long drive chain from the sprocket on the pocket chain shaft to the inside sprocket on the jackshaft of the direct drive wheel. The chain must go over the idler sprocket on the shoe brace and under the chain tightener sprocket as shown in the photo below.



5. Slide the red pipe spacer back onto the jackshaft. Insert the roll pin back into the second hole from the outside of the jackshaft. Slide the outside sprocket over the roll pin. Slide the drive chain coming from the drive wheel over the outside jackshaft sprocket. You may have to use your hand to push the chain tightener up to create enough slack in the chain. Insert the clip pin into the outside hole of the jackshaft.



6. Slide the outside chain guard onto the two pins and secure with clip pins.

Installation of Plant Stands

It is very important to know what row width will be used before installing the plant stands on multi-row transplanter. Follow the chart below.

- 42" Row Spacing - All Wide Plant Boxes
- 41" to 36" Row Spacing - Narrow Plant Boxes Inside
- 35" to 24" Row Spacing - One Wide Inside & Two Wide Outside
- 23" to 21" Row Spacing - One Narrow Inside & Two Wide Outside
- Less than 21" Row Spacing - Wide Outside Plant Boxes Only



1. Remove the long bolt between the uprights by the pocket chain. Do not lose the spacer between the uprights. Remove the outside cotter key in each axle.



2. Install the slotted mounting plates on both sides of the planter using the long bolt just removed. Do not tighten until the plant stand is fully assembled.



3. Slide plant stand onto the packing wheel axle and insert cotter key. Bend cotter key ends to keep in place.

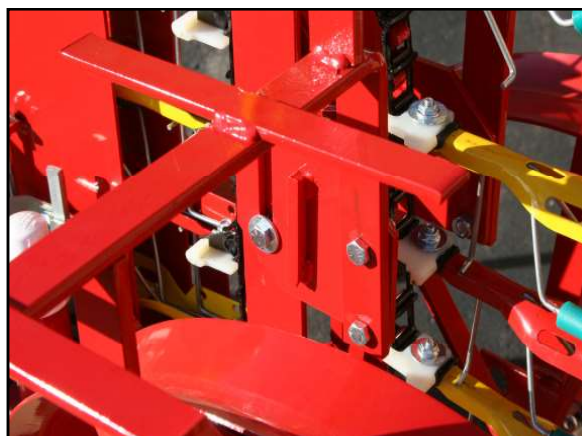

4. Use two 3/8 x 1" hex head bolts and two 3/8" nuts to attach plant stand frame to the slotted mounting bracket.



5. Attach the width adjustment plate with either the inside or outside hole depending on if you are using the wide (standard) plant boxes or the narrow with 3/8 x 1" hex head bolt and nut.

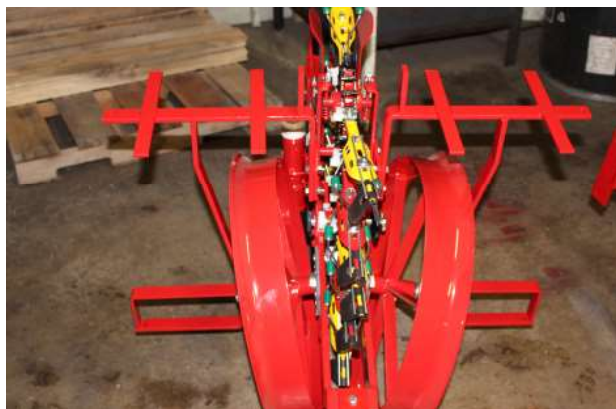

6. Install the plant boxes. These can be adjusted forward or backward for operator comfort.



Assembling the L-Shaped Seat Braces



1. Assemble the L-shaped seat brace by the chain guard. The sea brace mounts on the inside of the frame. The U-bolt mounts from the outside of the transplanter frame under the chain guard. Secure with 1/2" washers and 1/2" hex nuts over each threaded end.



2. The second L-shaped seat brace gets attached on the outside of the transplanter opposite the chain guard. The seat brace mounts on the outside of the frame with the U-bolt coming from the inside of the frame going outside through the seat brace. Secure with 1/2" washers and 1/2" hex nuts over each threaded end.

Mounting your Fiberglass or Cushion Seat

•Fiberglass Seats•



Fiberglass Seat - Turn your fiberglass seat over and remove any covers over the threaded studs. Take your green fiberglass seat bracket and mount it to the bottom of the seat with the side with the bend towards the front of the seat. Secure with four 1/4" hex nuts. Insert the 1/2 x 1-1/2 carriage bolt through the brace and then through the L-shaped seat bracket. Secure with a 1/2" washer and hex nut.

•Cushion Seats•

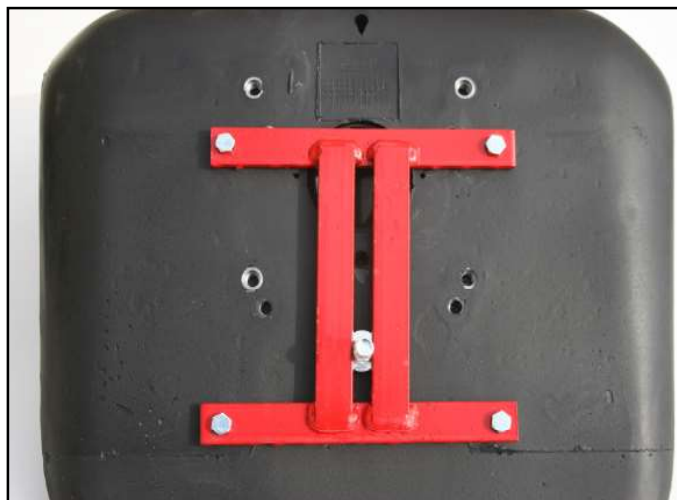

Cushion Seat - Slide the 1/2" x 1-1/2" carriage bolt through the bottom of the red seat bracket before mounting the seat bracket to the seat. After placing the carriage bolt through the seat bracket, place the seat on the L-shaped seat bracket and secure with a 1/2" washer and hex nut.

Loose Pocket Assembly

If your Model 1000 was shipped in a crate, a pocket must be put on the empty attachment link.

The empty attachment link should be right at the top of the chain when the unit is shipped. If it is not, turn the drive wheel until the empty attachment link comes to the top.



Do NOT put #445 rubber gripper onto spring wires(#440) until pocket is assembled to attachment link.

Take the extra V-3 pocket that is wired onto unit and loosen the pocket bolt. Put pocket bolt through the attachment link. Make sure spacing bar stays under the head of the bolt. Place #375 water trip on the back of attachment link, then the 1/4" fender washer. Secure with 1/4" flange nut. After the bolt has been tightened, slide the top part of the #445 rubber gripper to the #440 wire.

Instructions for Direct Drive Clamps

The following instructions are for mounting the direct drive clamps to your Model 1000 unit. Although the pictures show the 2-1/2" clamps, use these instructions for any clamp style. They all mount the same way.



1. Insert a metal bushing from the inside of the frame. Put one of the 1/2 x 1-1/2" bolts through the bushing also from the inside.



2. Attach the clamp to the bolt in the **top** hole of the bottom set of large holes. Secure with a 1/2" hex nut.
3. If you have a Model 1000B-3 or 1000-2 follow directions below for one clamp side only. To mount safety bar on other clamp side, see page 11. In the **top** set of holes, place a 7/16 x 1-1/4" bolt through the top hole.

4. Slide the end link of the chain onto the bolt.
5. Secure the chain with a 3/8" washer and then a 7/16" hex nut. Make sure the nut is very tight.





6. Use the same instructions for the other side of the Direct Drive Wheel.

Note: The clamps may be reversed or fastened on the inside of the frame for narrow row spacings. Also, if other clamps are in the way, two lefts or two rights may be used. The lower holes on the clamps are for higher toolbars on older models or on tractors where 3-point hitch will not go low enough. Correct height of toolbar is 14" to center.

The Model 1000 unit can now be mounted to your 3-point hitch or toolbar. Following is a list of fasteners that you must use for various toolbars.

Toolbar Hardware List

- 2-1/2" or 2-1/4" Diamond toolbar - 7/8" V-bend U-bolt (2)
- 3" x 3" Flat Toolbar - 3/4" x 5" Hex bolts (4)
- 4" x 4" Flat Toolbar - 3/4" x 6" Hex bolts (4)
- 4" x 7" Toolbar - 3/4" x 9-1/2" Hex bolts (4)
- 5" x 7" Toolbar - 3/4" x 7" Hex bolts (4)
- 7" x 7" Toolbar - 3/4" x 9-1/2" (4)



Shown with clamps reversed

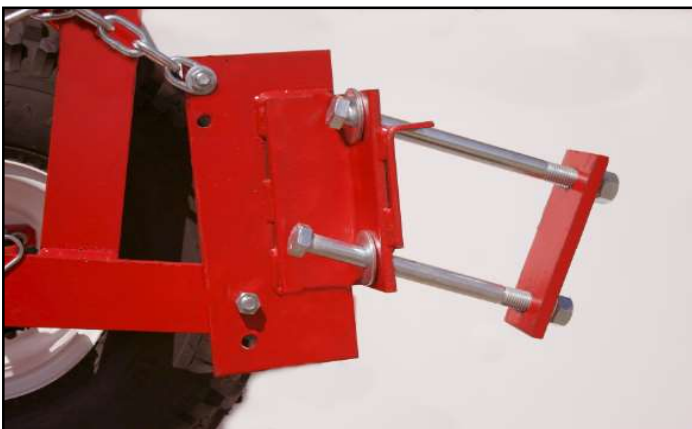

4 x 7 Toolbar Clamp. Use 2-3/4 x 9-1/2" hex bolts, 2-3/4" hex nuts and 2-3/4" washers.

Note: bent bracket on front of clamp

Model 1000B-3 Barrel Mounting & 3-Point Hitch Instructions



For B-3 Model, make sure the safety bar is properly installed!

To mount this safety bar, you must remove the 7/16 x 1-1/4" bolt from on side of the direct drive wheel.

1. Locate the special 2-1/2" stud in your bag of bolts and nuts.
2. Turn a 7/16" hex nut all the way onto the stud.
3. Put the 7/16" washer on the stud next to the nut.
4. Place the lift chain up against the washer.
5. Slide the stud through the hole on the Direct Drive frame and secure with a 7/16" hex nut.
6. Assemble another stud the same way and fasten it to the top hole of the front Direct Drive clamp.
7. Attach the red seat safety bar to the stud on your drive wheel. **The end with the hole must go on the clamp. The slotted end must go on the frame.** After the safety bar is attached, place the small clip pins through the small holes.

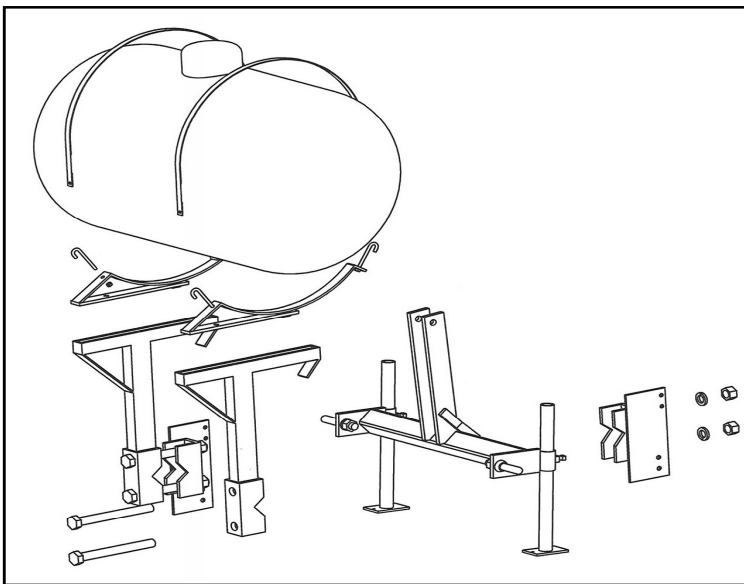

3-Point Hitch & Barrel Mounting

1. On the 3-point hitch, connect the Category I hitch pins through the holes on the outside of the hitch. Put the pins in through the outside and secure with the lock washer and hex nut included with the pin.
2. Slide the green pipe stands up through the pipes on the hitch, then tighten by turning the set screw.

Note: The following instructions will be easier with two people



3. Center the 3-point hitch toolbar with the clamps on your transplanter. Next, line up one of the barrel mounting brackets with the direct drive clamps. Secure using two 1 x 8-1/2 bolts and hex nuts. Do the same with the other barrel mounting bracket.



Side view of B-3 mountings



4. Bolt barrel hoops onto B-3 supports using 1/2 x 3" hex bolt with 1/2" lock nut. Note below: the hoops can be mounted in a forward or back position, depending on clearance that you need for the tractor fenders etc.



5. Screw in the nipple into the bottom of the tank.



6. Insert J-bolts into the four holes on the barrel hoops. It works best to thread 5/16" nut onto J-bolt before hooking up barrel hoops.



7. The 55 gallon poly tank can now be mounted on top of the barrel mountings. Use the four J-bolts and the galvanized straps to secure the barrel to the mountings.

A. Grease all fittings before the start of each day. Grease fittings are found:

1. On each packing wheel axle.
2. Upper pocket chain sprocket (Model 1000 only)
3. Direct drive tire hub (Direct Drive Units only)
4. On each nylon bushing on the pocket chain jackshaft.

B. Regulating Plant Depth

1. All operators should take care to see that the plants are placed well down in the pocket so the plant is held firmly.
2. The plant depth is regulated by the distance the root is extended out of the pocket.
3. To set the plants deeper, simply set the plant in the pocket with the roots further out than what is normally done. (See figure below)
4. If planting strawberries the axle must be raised up, allowing the transplanter unit to go deeper into the soil to cover the strawberry crowns.



V-3 Standard Plant Placement



Deeper Plant Placement

C. Pocket Chain Instructions

1. Make sure that bolts holding the upper sprocket on the pocket chain are not too tight. This will cause unnecessary friction on the unit and possible slippage on packing wheel drive transplanter. Simply loosen the wing nuts if the chain seems too tight.
2. Tighten the wing nuts equally by the top sprocket to keep the chain running level at all times.
3. If in row spacings of 20" or greater are needed, use only 6 pockets. You may remove every other pocket or leave them on. This gives the same speed or greater as a 12 pocket chain.

D. Adjusting or setting the #395R Round Point Shoe

Note: The shoe is preset at the factory for almost all situations.

Follow these instructions only if plants are leaning or in extreme wet or dry soil conditions.

1. Whenever any adjustments are made, be sure to get the shoe directly square and straight in front of the opening of the packing wheels. Make sure that the pockets will run through the middle of the shoe.
2. In loose dry soil, the shoe should be adjusted closer to the packing wheels. This can be done by adjusting the diagonal brace on the shoe.
3. In wet heavy soil, the shoe should be adjusted away from the packing wheels. Again, this can be done by adjusting the diagonal shoe brace.
4. Keep the shoe clean at all times. Do not allow dirt or trash to build up on the front or side of the shoe because this can cause too wide of a furrow that cannot be closed properly by the packing wheels. Poly covered shoes will eliminate this problem.

E. Water Valve Adjustment

1. For more water, make sure the valve is getting a full stroke by adjusting the #604 bracket on the pump rod. Make sure the valve does not over stroke. You should be able to lift the 604 rod 1/4-1/2" at the top of its stroke.
2. A broad range of adjustment can be achieved with the #603 water cam.
3. For wider spacings, the water cam may have to be raised so the water is on the plant. If the #603 is raised, be sure to raise the #604 water adjustment bracket accordingly and do not over stroke.

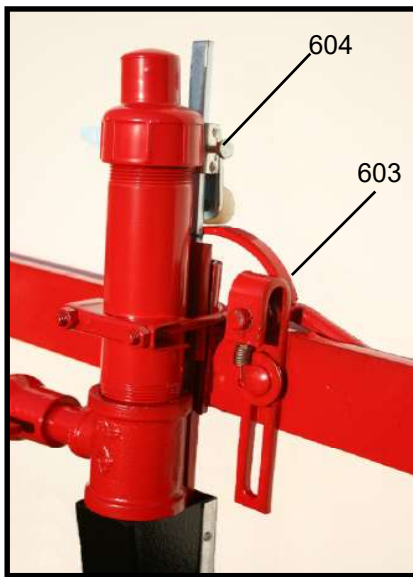

Example: At 20" row spacing, the #603 water cam should be adjusted nearly all the way up the slot. The #604 water adjustment must also be adjusted accordingly so a 1/2" remains on the 604 stroke.

4. Tilting the #603 water cam back towards the water trips on the pockets will create a longer stroke of water or more water before and after the plant.
5. Always empty the water out of the valve after quitting for the day. **Water freezing inside the valve will destroy the #610 and #612 balls inside the valve.**

F. Direct Drive Float Wheel Operation

1. Use only 4 to 5 pounds of air pressure in the Direct Drive Wheel during operation.



Wrong
Toolbar too high



Correct



Wrong
Toolbar too low

2. It is very important when starting to transplant, that the lift chains on the side of the Direct Drive Wheel are loose. See above "Correct" picture.
3. When lowering the transplanting unit into the ground, be sure that the frame members on the Direct Drive Wheel run parallel as is shown in the center picture. This is adjusted by the height of the hitch or toolbar (a pair of gauge wheels will eliminate adjustment of toolbar height).
4. Running the frame parallel will keep the lift chains loose allowing for proper floatation in the Direct Drive Wheel.
5. Running the frame members parallel and level will allow the packing wheels to run in the proper packing position.
6. Running the toolbar too low will tighten the back chains and cause the packing wheels to run too light and not pack the soil properly.
7. Running the toolbar too high will tighten the front lift chains and cause the Direct Drive Wheel to not run on the ground, especially through low spots.

Trouble Shooting

Important - Before attempting any of the following, make sure that the unit is running level or parallel to the ground. Do not run the front hitch or toolbar too far down or up. On all Model 1000 series units, make sure that the chains are loose on both sides of the arch bracket over the drive wheel. For all transplanter, make sure the soil is worked deep enough.

Problem

Solution

Packing wheels not packing properly

- A. Lengthen third arm on tractor to get float in hitch
- B. Hitch is too far down and needs to be lifted (lift chains are not loose)
- C. Clean off sides of shoe
- D. Work soil deeper
- E. Add weight to back of unit
- F. Poly shoes will eliminate soil building up on the outsides

Water leaks from top of water valve

- A. Check to see if the rubber nipple inside the top of the valve is in place and rounded.
- B. #610 ball inside the valve has collapsed and needs to be replaced.

Water leaks from bottom of water valve

- A. Rubber ball #612 on pin is broke and needs to be replaced
- B. The nylon nut on the bottom is broken and needs to be replaced

Water not uniform

- A. Make sure all the water trips on the pockets are in good shape and at even distances from the attachment link.
- B. Check to see that all springs on the water valve are in good working order.
- C. Water valve has dirt or residue build up that needs to be cleaned out

Water misses plants

•See water valve instructions on Page13.

Plants falling out of pocket

- A. Inspect the rubber grippers to make sure that they are not all stretched out.
- B. Tighten the L-bolts on the side of the guides.
- C. #482 pocket extensions may be needed if planting cell-type plants.
- D. Check bottom of guides to insure that the pocket is not releasing the plant too soon.

Plants on top of soil

- A. Cut back on water because the plants are floating up out of the shoe.
- B. Plants need to be pulled further out of the pocket to put them deeper.
- C. Too much loose soil is getting inside the shoe before the packing wheels can pack. Move shoe closer to packing wheels.
- D. A gap might be occurring by having the hitch too low causing the packing wheels to be up in the air or not being able to put enough pressure on the soil.
- E. Ground not worked deep enough causing the shoe to not go deep enough into the soil.

Plants leaning

- A. Need to put plant further in the pocket to keep it from hitting the bottom of the furrow.
- B. Possibility of needing a deeper shoe.
- C. May need #482 extensions to help support the cell of a plant coming from a tray.
- D. See Operating Instructions on Page 13 about adjusting the shoe.

Safety Precautions

1. Make sure tractor is stopped and in neutral with the transplanter lowered to the ground before getting on and off the unit.
2. No operator is allowed to be on the unit as it is raised and lowered.
3. No operator is allowed on the transplanter as it is transported to or from the field.
4. All operators must be seated before movement begins and remain seated until the transplanter is completely stopped.
5. Never leave the transplanter in the raised position.
6. Keep all shields and guards in place when operating the transplanter.
7. Never attempt repairs or maintenance while the transplanter is in motion.
8. Never put the tractor in reverse while the transplanter is on the ground.
9. Follow all safety instructions supplied by the tractor manufacturer to which the transplanter is mounted.

MACHINE IMPROVEMENTS

MECHANICAL TRANSPLANTER CO. IS ALWAYS STRIVING TO MAKE IMPROVEMENTS ON THEIR LINE OF EQUIPMENT. MECHANICAL TRANSPLANTER CO. RESERVES THE RIGHT TO MAKE IMPROVEMENTS AND CHANGES AT ANY TIME WITHOUT INCURRING OBLIGATIONS TO MAKE SUCH CHANGES OR ADDITIONS TO EQUIPMENT PREVIOUSLY SOLD.

Limited Warranty

Mechanical Transplanter Company warrants each item of new equipment manufactured by Mechanical to be free from defects in material and workmanship under normal use and service.

The obligation of Mechanical Transplanter Company under this LIMITED WARRANTY is limited to repairing or replacing as Mechanical may elect, and any parts that prove, in Mechanical's judgment, to be defective in material and workmanship within the first season's use or 45 consecutive days after initially placing equipment in operation, whichever occurs first. Any outside work or alterations without Mechanical's written approval will render the LIMITED WARRANTY void.

Mechanical's obligation specifically excludes any liability for consequential damages, such as loss of profits, delays, expenses, damage to goods or property used in connection with or processed in or by the product sold, or damage to the product sold from whatsoever cause, whether or not such loss is due to negligence of selling dealer of Mechanical Transplanter Company.

This limited warranty shall not apply to any item or machine which shall have been operated in a manner not recommended by the Company nor which shall have been repaired, altered, misused, damaged in an accident, neglected, tampered with or used in any way which in the Company's opinion adversely affects its performance and results.

No person is authorized to give any other warranties or to assume any other liability on behalf of Mechanical Transplanter Company, unless made in writing by Mechanical.

This limited warranty covers repair or replacement of Mechanical Transplanter Co. equipment only and does not cover crop loss, downtime, labor, damage to other equipment, etc.

This limited warranty does not apply to exterior finishes, tires, chain links, bearings, or any other items sold by Mechanical Transplanter Co., but warranted by the original manufacturer except to the extent of their individual manufacturer's warranty.

THIS LIMITED WARRANTY IS IN LIEU OF ALL OTHER WARRANTIES, EXPRESSED OR IMPLIED. WARRANTIES OF MERCHANTABILITY AND FITNESS FOR PARTICULAR PURPOSE ARE EXCLUDED, AS ARE ALL OTHER REPRESENTATIONS TO THE USER-PURCHASER, AND ALL OTHER OBLIGATIONS OR LIABILITIES, INCLUDING LIABILITY FOR INCIDENTAL AND CONSEQUENTIAL DAMAGES, ON THE PART OF MECHANICAL OR THE SELLER.

Mechanical Transplanter Co.

Model 1000 and 1000B-3

Operators Manual



Mechanical Transplanter Co., LLC
1150 Central Avenue • Holland, MI 49423-5230
Phone: 616-396-8738 • Fax: 616-396-3619
website: www.mechanicaltransplanter.com
e-mail: mtc@mechanicaltransplanter.com

Spacing Charts and Information

| SPACING CHART FOR DIRECT DRIVE UNIT W/ 12 POCKET CHAIN | | | | | | |
|---|---------------------------------|-------------------------------------|-----------------------|-----------------------|-------------------|-----------------|
| Sprocket on OUT-SIDE of Jackshaft | Sprocket on INSIDE of Jackshaft | Number of Teeth on Sprocket on Unit | | | | |
| | | 7 | 8 | 9 | 10 | 11 |
| 7 | 11 | 6" 15.2cm | 6-1/2" - 7" 17.8cm | 7-1/2" - 8" 20.3cm | 8-1/2" 21.6cm | 9" 22.8cm |
| 7 | 7 | 9" 22.8cm | 10-1/2" 26.7cm | 13" 33cm | 15" 38.1cm | 16" 40.6cm |
| 8 | 7 | 10-1/2" 26.7cm | 12-1/2" 31.7cm | 14" 35.5cm | 15" 38.1cm | 16" 40.6cm |
| 9 | 7 | 12" 30.5cm | 13-1/2" 34.3cm | 15" 38.1cm | 17" 43.2cm | 18-1/2" 47cm |
| 10 | 7 | 13" 33cm | 14" 35.5cm | 15-1/2" 39.4cm | 17-1/2" 44.5cm | 20-1/2" 52cm |
| 11 | 7 | 15" 38.1cm | 18" 45.7cm | | | |

Double any of the above spacings by using every other pocket (6 pocket).
Make sure HITCH and UNIT are level or parallel to the ground when planting.

Use for Model 1000

| DISC SPACING CHART FOR MODELS W/ DIRECT DRIVE | | | | | | | |
|--|---------------------------------|-------------------------------|-------------------------------------|--------|--------|--------|--------|
| Sprocket on OUTSIDE of Jackshaft | Sprocket on INSIDE of Jackshaft | Number of Pockets on the Disc | Number of Teeth on Sprocket by Disc | | | | |
| | | | 7 | 8 | 9 | 10 | 11 |
| 7 | 7 | 24 | | 2" | 2-1/4" | 2-1/2" | 2-3/4" |
| | | 16 | 3" | 3-1/4" | 3-1/2" | 4" | 4-1/2" |
| | | 12 | | 4-3/4" | 5-1/4" | 5-3/4" | 6-1/4" |
| 8 | 7 | 24 | | 2-1/2" | 3" | 3-1/4" | 3-1/2" |
| | | 16 | 3-1/2" | 3-3/4" | 4-1/4" | 4-1/2" | 5-1/4" |
| | | 12 | | 6" | 6-1/4" | 6-3/4" | 7" |
| 9 | 7 | 24 | 2-1/2" | 2-3/4" | 3-1/4" | 3-1/2" | 4" |
| | | 16 | 3-3/4" | 4-1/4" | 4-1/2" | 5" | 5-1/2" |
| | | 12 | 4-1/2" | 6-1/4" | 6-1/2" | 7-1/4" | 8" |
| 10 | 7 | 24 | 2-1/2" | 3" | 3-1/2" | 3-3/4" | 4-1/2" |
| | | 16 | 3-3/4" | 4-1/2" | 5-1/4" | | |
| | | 12 | 5-1/4" | 6" | 7" | 7-1/2" | 8-1/2" |
| 11 | 7 | 24 | 2-1/2" | 3" | 3-1/2" | 4-1/4" | 4-3/4" |
| | | 16 | 4" | 5" | 6" | | |
| | | 12 | 5-1/2" | 6-1/2" | 7-1/2" | 9" | 10" |

Use for Model 1000 with disc mounted pockets

Assembly Instructions

For Model 1000 Series Transplanters

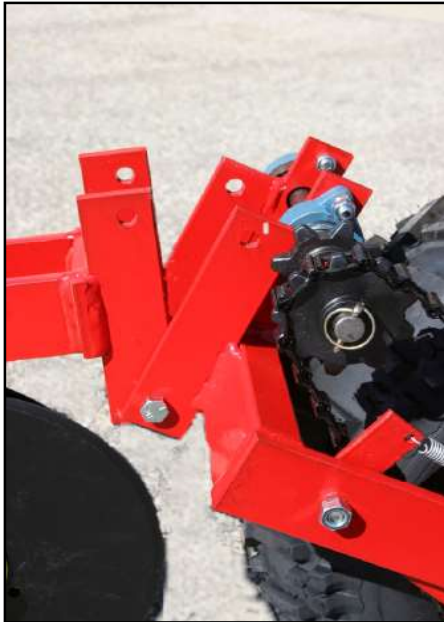

1. Bolt on the Direct Drive Float Wheel using the four 1/2 x 1-1/2 " bolts. Secure using the 1/2" hex nuts.



2. Remove the following parts from the direct drive wheel jackshaft: Clip pin, drive chain coming from the wheel, outside sprocket on jackshaft, and pipe spacer. Then remove the extra top hex nut located on the flange bearing.



3. Install the inside chain guard of the unit. Fasten front short tab to the top bolt on flange bearing from #2 photo with hex nut. The long tab attaches to the empty hole on the transplanter frame by the packing wheels. The guard must fit between the shoe brace and the guide adjustment bolt. Use the 3/8 x 1" bolt and a 3/8" hex nut to secure.

4. Select the proper sprocket arrangement for the spacing needed between plants. Look on page 2 or the chart on the side of your transplanter for the correct arrangement. For spacings using 11 tooth sprockets, extra chain links may be needed to lengthen the drive chain. These links are wired to the lift chain by the drive wheel. After finding the correct sprockets, run the long drive chain from the sprocket on the pocket chain shaft to the inside sprocket on the jackshaft of the direct drive wheel. The chain must go over the idler sprocket on the shoe brace and under the chain tightener sprocket as shown in the photo below.



5. Slide the red pipe spacer back onto the jackshaft. Insert the roll pin back into the second hole from the outside of the jackshaft. Slide the outside sprocket over the roll pin. Slide the drive chain coming from the drive wheel over the outside jackshaft sprocket. You may have to use your hand to push the chain tightener up to create enough slack in the chain. Insert the clip pin into the outside hole of the jackshaft.



6. Slide the outside chain guard onto the two pins and secure with clip pins.

Installation of Plant Stands

It is very important to know what row width will be used before installing the plant stands on multi-row transplanter. Follow the chart below.

- 42" Row Spacing - All Wide Plant Boxes
- 41" to 36" Row Spacing - Narrow Plant Boxes Inside
- 35" to 24" Row Spacing - One Wide Inside & Two Wide Outside
- 23" to 21" Row Spacing - One Narrow Inside & Two Wide Outside
- Less than 21" Row Spacing - Wide Outside Plant Boxes Only



1. Remove the long bolt between the uprights by the pocket chain. Do not lose the spacer between the uprights. Remove the outside cotter key in each axle.



2. Install the slotted mounting plates on both sides of the planter using the long bolt just removed. Do not tighten until the plant stand is fully assembled.



3. Slide plant stand onto the packing wheel axle and insert cotter key. Bend cotter key ends to keep in place.

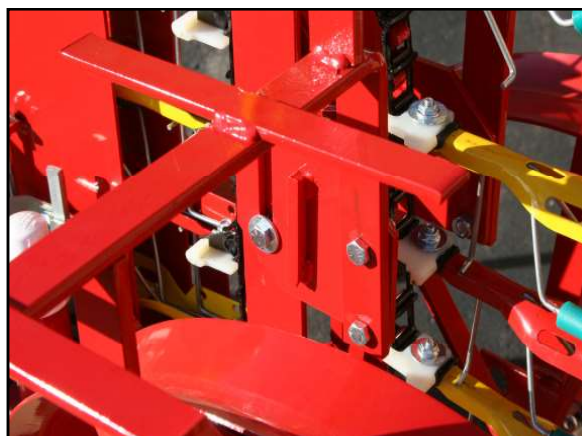

4. Use two 3/8 x 1" hex head bolts and two 3/8" nuts to attach plant stand frame to the slotted mounting bracket.



5. Attach the width adjustment plate with either the inside or outside hole depending on if you are using the wide (standard) plant boxes or the narrow with 3/8 x 1" hex head bolt and nut.

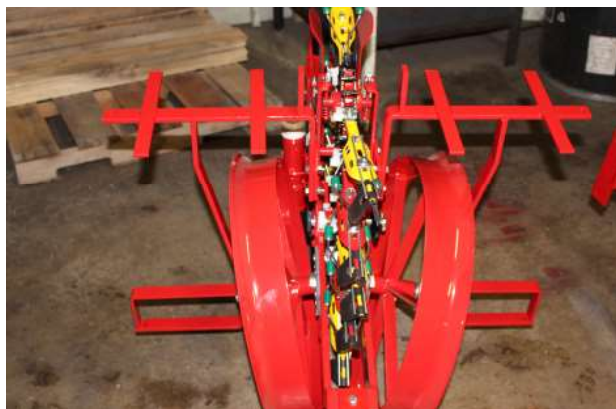

6. Install the plant boxes. These can be adjusted forward or backward for operator comfort.



Assembling the L-Shaped Seat Braces



1. Assemble the L-shaped seat brace by the chain guard. The sea brace mounts on the inside of the frame. The U-bolt mounts from the outside of the transplanter frame under the chain guard. Secure with 1/2" washers and 1/2" hex nuts over each threaded end.



2. The second L-shaped seat brace gets attached on the outside of the transplanter opposite the chain guard. The seat brace mounts on the outside of the frame with the U-bolt coming from the inside of the frame going outside through the seat brace. Secure with 1/2" washers and 1/2" hex nuts over each threaded end.

Mounting your Fiberglass or Cushion Seat

•Fiberglass Seats•



Fiberglass Seat - Turn your fiberglass seat over and remove any covers over the threaded studs. Take your green fiberglass seat bracket and mount it to the bottom of the seat with the side with the bend towards the front of the seat. Secure with four 1/4" hex nuts. Insert the 1/2 x 1-1/2 carriage bolt through the brace and then through the L-shaped seat bracket. Secure with a 1/2" washer and hex nut.

•Cushion Seats•

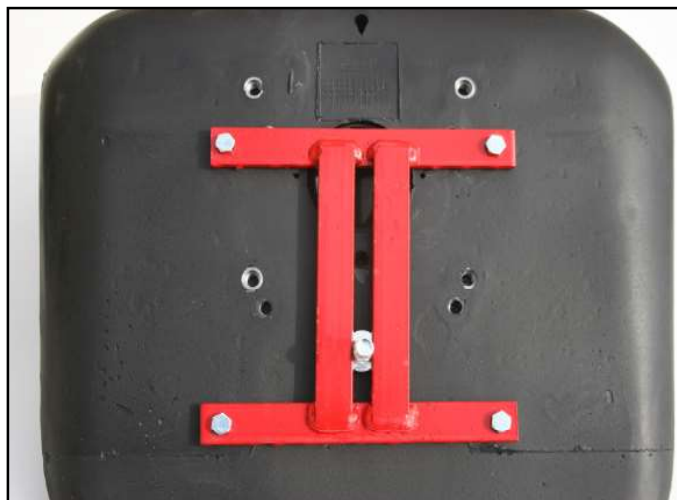

Cushion Seat - Slide the 1/2" x 1-1/2" carriage bolt through the bottom of the red seat bracket before mounting the seat bracket to the seat. After placing the carriage bolt through the seat bracket, place the seat bracket on the cushion seat. Secure with four 5/16" x 1" hex head bolts. Place the seat on the L-shaped seat bracket and secure with a 1/2" washer and hex nut.

Loose Pocket Assembly

If your Model 1000 was shipped in a crate, a pocket must be put on the empty attachment link.

The empty attachment link should be right at the top of the chain when the unit is shipped. If it is not, turn the drive wheel until the empty attachment link comes to the top.



Do **NOT** put #445 rubber gripper onto spring wires(#440) until pocket is assembled to attachment link.

Take the extra V-3 pocket that is wired onto unit and loosen the pocket bolt. Put pocket bolt through the attachment link. Make sure spacing bar stays under the head of the bolt. Place #375 water trip on the back of attachment link, then the 1/4" fender washer. Secure with 1/4" flange nut. After the bolt has been tightened, slide the top part of the #445 rubber gripper to the #440 wire.

Instructions for Direct Drive Clamps

The following instructions are for mounting the direct drive clamps to your Model 1000 unit. Although the pictures show the 2-1/2" clamps, use these instructions for any clamp style. They all mount the same way.



1. Insert a metal bushing from the inside of the frame. Put one of the 1/2 x 1-1/2" bolts through the bushing also from the inside.



2. Attach the clamp to the bolt in the **top** hole of the bottom set of large holes. Secure with a 1/2" hex nut.
3. If you have a Model 1000B-3 or 1000-2 follow directions below for one clamp side only. To mount safety bar on other clamp side, see page 11. In the **top** set of holes, place a 7/16 x 1-1/4" bolt through the top hole.

4. Slide the end link of the chain onto the bolt.
5. Secure the chain with a 3/8" washer and then a 7/16" hex nut. Make sure the nut is very tight.





6. Use the same instructions for the other side of the Direct Drive Wheel.

Note: The clamps may be reversed or fastened on the inside of the frame for narrow row spacings. Also, if other clamps are in the way, two lefts or two rights may be used. The lower holes on the clamps are for higher toolbars on older models or on tractors where 3-point hitch will not go low enough. Correct height of toolbar is 14" to center.

The Model 1000 unit can now be mounted to your 3-point hitch or toolbar. Following is a list of fasteners that you must use for various toolbars.

Toolbar Hardware List

- 2-1/2" or 2-1/4" Diamond toolbar - 7/8" V-bend U-bolt (2)
- 3" x 3" Flat Toolbar - 3/4" x 5" Hex bolts (4)
- 4" x 4" Flat Toolbar - 3/4" x 6" Hex bolts (4)
- 4" x 7" Toolbar - 3/4" x 9-1/2" Hex bolts (4)
- 5" x 7" Toolbar - 3/4" x 7" Hex bolts (4)
- 7" x 7" Toolbar - 3/4" x 9-1/2" (4)



Shown with clamps reversed

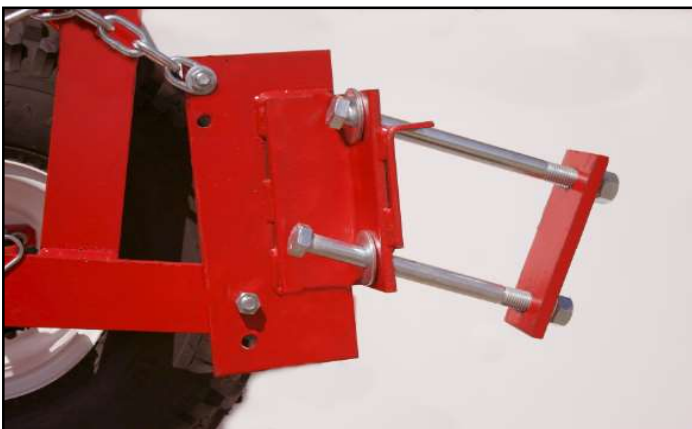

4 x 7 Toolbar Clamp. Use 2-3/4 x 9-1/2" hex bolts, 2-3/4" hex nuts and 2-3/4" washers.

Note: bent bracket on front of clamp

Model 1000B-3 Barrel Mounting & 3-Point Hitch Instructions



For B-3 Model, make sure the safety bar is properly installed!

To mount this safety bar, you must remove the 7/16 x 1-1/4" bolt from on side of the direct drive wheel.

1. Locate the special 2-1/2" stud in your bag of bolts and nuts.
2. Turn a 7/16" hex nut all the way onto the stud.
3. Put the 7/16" washer on the stud next to the nut.
4. Place the lift chain up against the washer.
5. Slide the stud through the hole on the Direct Drive frame and secure with a 7/16" hex nut.
6. Assemble another stud the same way and fasten it to the top hole of the front Direct Drive clamp.
7. Attach the red seat safety bar to the stud on your drive wheel. **The end with the hole must go on the clamp. The slotted end must go on the frame.** After the safety bar is attached, place the small clip pins through the small holes.

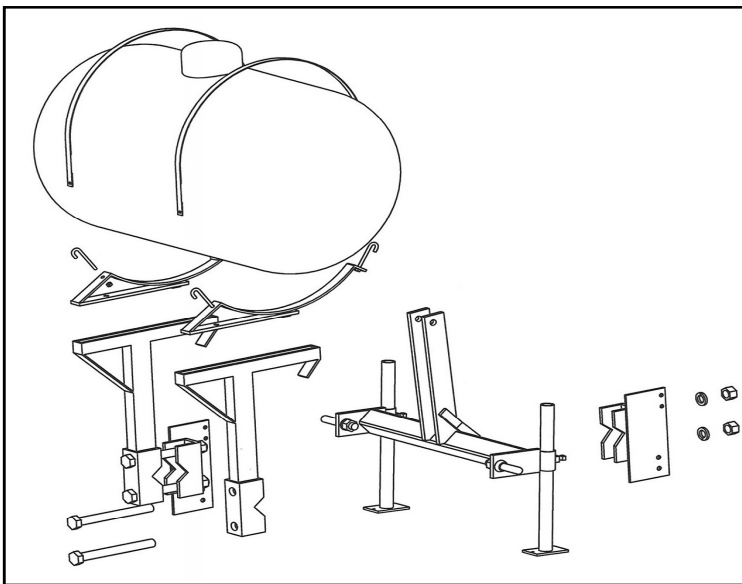

3-Point Hitch & Barrel Mounting

1. On the 3-point hitch, connect the Category I hitch pins through the holes on the outside of the hitch. Put the pins in through the outside and secure with the lock washer and hex nut included with the pin.
2. Slide the green pipe stands up through the pipes on the hitch, then tighten by turning the set screw.

Note: The following instructions will be easier with two people



3. Center the 3-point hitch toolbar with the clamps on your transplanter. Next, line up one of the barrel mounting brackets with the direct drive clamps. Secure using two 1 x 8-1/2 bolts and hex nuts. Do the same with the other barrel mounting bracket.



Side view of B-3 mountings



4. Bolt barrel hoops onto B-3 supports using 1/2 x 3" hex bolt with 1/2" lock nut. Note below: the hoops can be mounted in a forward or back position, depending on clearance that you need for the tractor fenders etc.



5. Screw in the nipple into the bottom of the tank.



6. Insert J-bolts into the four holes on the barrel hoops. It works best to thread 5/16" nut onto J-bolt before hooking up barrel hoops.



7. The 55 gallon poly tank can now be mounted on top of the barrel mountings. Use the four J-bolts and the galvanized straps to secure the barrel to the mountings.

A. Grease all fittings before the start of each day. Grease fittings are found:

1. On each packing wheel axle.
2. Upper pocket chain sprocket (Model 1000 only)
3. Direct drive tire hub (Direct Drive Units only)
4. On each nylon bushing on the pocket chain jackshaft.

B. Regulating Plant Depth

1. All operators should take care to see that the plants are placed well down in the pocket so the plant is held firmly.
2. The plant depth is regulated by the distance the root is extended out of the pocket.
3. To set the plants deeper, simply set the plant in the pocket with the roots further out than what is normally done. (See figure below)
4. If planting strawberries the axle must be raised up, allowing the transplanter unit to go deeper into the soil to cover the strawberry crowns.



V-3 Standard Plant Placement



Deeper Plant Placement

C. Pocket Chain Instructions

1. Make sure that bolts holding the upper sprocket on the pocket chain are not too tight. This will cause unnecessary friction on the unit and possible slippage on packing wheel drive transplanter. Simply loosen the wing nuts if the chain seems too tight.
2. Tighten the wing nuts equally by the top sprocket to keep the chain running level at all times.
3. If in row spacings of 20" or greater are needed, use only 6 pockets. You may remove every other pocket or leave them on. This gives the same speed or greater as a 12 pocket chain.

D. Adjusting or setting the #395R Round Point Shoe

Note: The shoe is preset at the factory for almost all situations.

Follow these instructions only if plants are leaning or in extreme wet or dry soil conditions.

1. Whenever any adjustments are made, be sure to get the shoe directly square and straight in front of the opening of the packing wheels. Make sure that the pockets will run through the middle of the shoe.
2. In loose dry soil, the shoe should be adjusted closer to the packing wheels. This can be done by adjusting the diagonal brace on the shoe.
3. In wet heavy soil, the shoe should be adjusted away from the packing wheels. Again, this can be done by adjusting the diagonal shoe brace.
4. Keep the shoe clean at all times. Do not allow dirt or trash to build up on the front or side of the shoe because this can cause too wide of a furrow that cannot be closed properly by the packing wheels. Poly covered shoes will eliminate this problem.

E. Water Valve Adjustment

1. For more water, make sure the valve is getting a full stroke by adjusting the #604 bracket on the pump rod. Make sure the valve does not over stroke. You should be able to lift the 604 rod 1/4-1/2" at the top of its stroke.
2. A broad range of adjustment can be achieved with the #603 water cam.
3. For wider spacings, the water cam may have to be raised so the water is on the plant. If the #603 is raised, be sure to raise the #604 water adjustment bracket accordingly and do not over stroke.

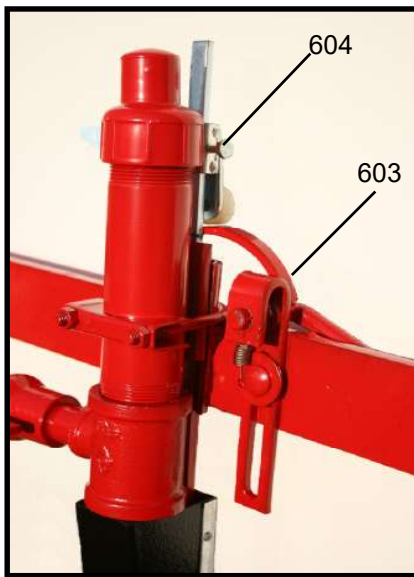

Example: At 20" row spacing, the #603 water cam should be adjusted nearly all the way up the slot. The #604 water adjustment must also be adjusted accordingly so a 1/2" remains on the 604 stroke.

4. Tilting the #603 water cam back towards the water trips on the pockets will create a longer stroke of water or more water before and after the plant.
5. Always empty the water out of the valve after quitting for the day. **Water freezing inside the valve will destroy the #610 and #612 balls inside the valve.**

F. Direct Drive Float Wheel Operation

1. Use only 4 to 5 pounds of air pressure in the Direct Drive Wheel during operation.



Wrong
Toolbar too high



Correct



Wrong
Toolbar too low

2. It is very important when starting to transplant, that the lift chains on the side of the Direct Drive Wheel are loose. See above "Correct" picture.
3. When lowering the transplanting unit into the ground, be sure that the frame members on the Direct Drive Wheel run parallel as is shown in the center picture. This is adjusted by the height of the hitch or toolbar (a pair of gauge wheels will eliminate adjustment of toolbar height).
4. Running the frame parallel will keep the lift chains loose allowing for proper floatation in the Direct Drive Wheel.
5. Running the frame members parallel and level will allow the packing wheels to run in the proper packing position.
6. Running the toolbar too low will tighten the back chains and cause the packing wheels to run too light and not pack the soil properly.
7. Running the toolbar too high will tighten the front lift chains and cause the Direct Drive Wheel to not run on the ground, especially through low spots.

Trouble Shooting

Important - Before attempting any of the following, make sure that the unit is running level or parallel to the ground. Do not run the front hitch or toolbar too far down or up. On all Model 1000 series units, make sure that the chains are loose on both sides of the arch bracket over the drive wheel. For all transplanter, make sure the soil is worked deep enough.

Problem

Solution

Packing wheels not packing properly

- A. Lengthen third arm on tractor to get float in hitch
- B. Hitch is too far down and needs to be lifted (lift chains are not loose)
- C. Clean off sides of shoe
- D. Work soil deeper
- E. Add weight to back of unit
- F. Poly shoes will eliminate soil building up on the outsides

Water leaks from top of water valve

- A. Check to see if the rubber nipple inside the top of the valve is in place and rounded.
- B. #610 ball inside the valve has collapsed and needs to be replaced.

Water leaks from bottom of water valve

- A. Rubber ball #612 on pin is broke and needs to be replaced
- B. The nylon nut on the bottom is broken and needs to be replaced

Water not uniform

- A. Make sure all the water trips on the pockets are in good shape and at even distances from the attachment link.
- B. Check to see that all springs on the water valve are in good working order.
- C. Water valve has dirt or residue build up that needs to be cleaned out

Water misses plants

•See water valve instructions on Page13.

Plants falling out of pocket

- A. Inspect the rubber grippers to make sure that they are not all stretched out.
- B. Tighten the L-bolts on the side of the guides.
- C. #482 pocket extensions may be needed if planting cell-type plants.
- D. Check bottom of guides to insure that the pocket is not releasing the plant too soon.

Plants on top of soil

- A. Cut back on water because the plants are floating up out of the shoe.
- B. Plants need to be pulled further out of the pocket to put them deeper.
- C. Too much loose soil is getting inside the shoe before the packing wheels can pack. Move shoe closer to packing wheels.
- D. A gap might be occurring by having the hitch too low causing the packing wheels to be up in the air or not being able to put enough pressure on the soil.
- E. Ground not worked deep enough causing the shoe to not go deep enough into the soil.

Plants leaning

- A. Need to put plant further in the pocket to keep it from hitting the bottom of the furrow.
- B. Possibility of needing a deeper shoe.
- C. May need #482 extensions to help support the cell of a plant coming from a tray.
- D. See Operating Instructions on Page 13 about adjusting the shoe.

Safety Precautions

1. Make sure tractor is stopped and in neutral with the transplanter lowered to the ground before getting on and off the unit.
2. No operator is allowed to be on the unit as it is raised and lowered.
3. No operator is allowed on the transplanter as it is transported to or from the field.
4. All operators must be seated before movement begins and remain seated until the transplanter is completely stopped.
5. Never leave the transplanter in the raised position.
6. Keep all shields and guards in place when operating the transplanter.
7. Never attempt repairs or maintenance while the transplanter is in motion.
8. Never put the tractor in reverse while the transplanter is on the ground.
9. Follow all safety instructions supplied by the tractor manufacturer to which the transplanter is mounted.

MACHINE IMPROVEMENTS

MECHANICAL TRANSPLANTER CO. IS ALWAYS STRIVING TO MAKE IMPROVEMENTS ON THEIR LINE OF EQUIPMENT. MECHANICAL TRANSPLANTER CO. RESERVES THE RIGHT TO MAKE IMPROVEMENTS AND CHANGES AT ANY TIME WITHOUT INCURRING OBLIGATIONS TO MAKE SUCH CHANGES OR ADDITIONS TO EQUIPMENT PREVIOUSLY SOLD.

Limited Warranty

Mechanical Transplanter Company warrants each item of new equipment manufactured by Mechanical to be free from defects in material and workmanship under normal use and service.

The obligation of Mechanical Transplanter Company under this LIMITED WARRANTY is limited to repairing or replacing as Mechanical may elect, and any parts that prove, in Mechanical's judgment, to be defective in material and workmanship within the first season's use or 45 consecutive days after initially placing equipment in operation, whichever occurs first. Any outside work or alterations without Mechanical's written approval will render the LIMITED WARRANTY void.

Mechanical's obligation specifically excludes any liability for consequential damages, such as loss of profits, delays, expenses, damage to goods or property used in connection with or processed in or by the product sold, or damage to the product sold from whatsoever cause, whether or not such loss is due to negligence of selling dealer of Mechanical Transplanter Company.

This limited warranty shall not apply to any item or machine which shall have been operated in a manner not recommended by the Company nor which shall have been repaired, altered, misused, damaged in an accident, neglected, tampered with or used in any way which in the Company's opinion adversely affects its performance and results.

No person is authorized to give any other warranties or to assume any other liability on behalf of Mechanical Transplanter Company, unless made in writing by Mechanical.

This limited warranty covers repair or replacement of Mechanical Transplanter Co. equipment only and does not cover crop loss, downtime, labor, damage to other equipment, etc.

This limited warranty does not apply to exterior finishes, tires, chain links, bearings, or any other items sold by Mechanical Transplanter Co., but warranted by the original manufacturer except to the extent of their individual manufacturer's warranty.

THIS LIMITED WARRANTY IS IN LIEU OF ALL OTHER WARRANTIES, EXPRESSED OR IMPLIED. WARRANTIES OF MERCHANTABILITY AND FITNESS FOR PARTICULAR PURPOSE ARE EXCLUDED, AS ARE ALL OTHER REPRESENTATIONS TO THE USER-PURCHASER, AND ALL OTHER OBLIGATIONS OR LIABILITIES, INCLUDING LIABILITY FOR INCIDENTAL AND CONSEQUENTIAL DAMAGES, ON THE PART OF MECHANICAL OR THE SELLER.

Mechanical Transplanter Co.

Model 1000 and 1000B-3

Operators Manual



Mechanical Transplanter Co., LLC
1150 Central Avenue • Holland, MI 49423-5230
Phone: 616-396-8738 • Fax: 616-396-3619
website: www.mechanicaltransplanter.com
e-mail: mtc@mechanicaltransplanter.com

Spacing Charts and Information

| SPACING CHART FOR DIRECT DRIVE UNIT W/ 12 POCKET CHAIN | | | | | | |
|---|---------------------------------|-------------------------------------|-----------------------|-----------------------|-------------------|-----------------|
| Sprocket on OUT-SIDE of Jackshaft | Sprocket on INSIDE of Jackshaft | Number of Teeth on Sprocket on Unit | | | | |
| | | 7 | 8 | 9 | 10 | 11 |
| 7 | 11 | 6" 15.2cm | 6-1/2" - 7" 17.8cm | 7-1/2" - 8" 20.3cm | 8-1/2" 21.6cm | 9" 22.8cm |
| 7 | 7 | 9" 22.8cm | 10-1/2" 26.7cm | 13" 33cm | 15" 38.1cm | 16" 40.6cm |
| 8 | 7 | 10-1/2" 26.7cm | 12-1/2" 31.7cm | 14" 35.5cm | 15" 38.1cm | 16" 40.6cm |
| 9 | 7 | 12" 30.5cm | 13-1/2" 34.3cm | 15" 38.1cm | 17" 43.2cm | 18-1/2" 47cm |
| 10 | 7 | 13" 33cm | 14" 35.5cm | 15-1/2" 39.4cm | 17-1/2" 44.5cm | 20-1/2" 52cm |
| 11 | 7 | 15" 38.1cm | 18" 45.7cm | | | |

Double any of the above spacings by using every other pocket (6 pocket).
Make sure HITCH and UNIT are level or parallel to the ground when planting.

Use for Model 1000

| DISC SPACING CHART FOR MODELS W/ DIRECT DRIVE | | | | | | | |
|--|---------------------------------|-------------------------------|-------------------------------------|--------|--------|--------|--------|
| Sprocket on OUTSIDE of Jackshaft | Sprocket on INSIDE of Jackshaft | Number of Pockets on the Disc | Number of Teeth on Sprocket by Disc | | | | |
| | | | 7 | 8 | 9 | 10 | 11 |
| 7 | 7 | 24 | | 2" | 2-1/4" | 2-1/2" | 2-3/4" |
| | | 16 | 3" | 3-1/4" | 3-1/2" | 4" | 4-1/2" |
| | | 12 | | 4-3/4" | 5-1/4" | 5-3/4" | 6-1/4" |
| 8 | 7 | 24 | | 2-1/2" | 3" | 3-1/4" | 3-1/2" |
| | | 16 | 3-1/2" | 3-3/4" | 4-1/4" | 4-1/2" | 5-1/4" |
| | | 12 | | 6" | 6-1/4" | 6-3/4" | 7" |
| 9 | 7 | 24 | 2-1/2" | 2-3/4" | 3-1/4" | 3-1/2" | 4" |
| | | 16 | 3-3/4" | 4-1/4" | 4-1/2" | 5" | 5-1/2" |
| | | 12 | 4-1/2" | 6-1/4" | 6-1/2" | 7-1/4" | 8" |
| 10 | 7 | 24 | 2-1/2" | 3" | 3-1/2" | 3-3/4" | 4-1/2" |
| | | 16 | 3-3/4" | 4-1/2" | 5-1/4" | | |
| | | 12 | 5-1/4" | 6" | 7" | 7-1/2" | 8-1/2" |
| 11 | 7 | 24 | 2-1/2" | 3" | 3-1/2" | 4-1/4" | 4-3/4" |
| | | 16 | 4" | 5" | 6" | | |
| | | 12 | 5-1/2" | 6-1/2" | 7-1/2" | 9" | 10" |

Use for Model 1000 with disc mounted pockets

Assembly Instructions

For Model 1000 Series Transplanters

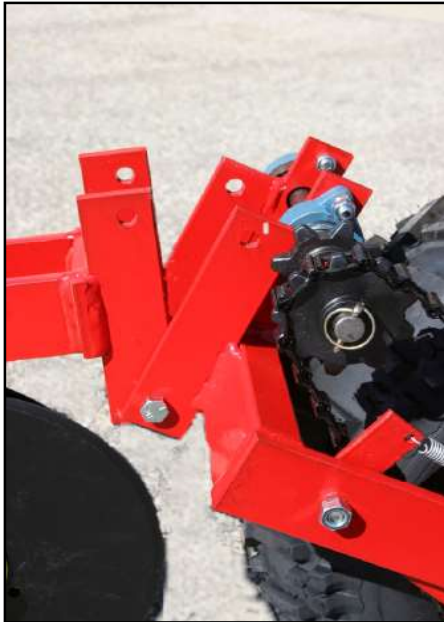

1. Bolt on the Direct Drive Float Wheel using the four 1/2 x 1-1/2 " bolts. Secure using the 1/2" hex nuts.



2. Remove the following parts from the direct drive wheel jackshaft: Clip pin, drive chain coming from the wheel, outside sprocket on jackshaft, and pipe spacer. Then remove the extra top hex nut located on the flange bearing.



3. Install the inside chain guard of the unit. Fasten front short tab to the top bolt on flange bearing from #2 photo with hex nut. The long tab attaches to the empty hole on the transplanter frame by the packing wheels. The guard must fit between the shoe brace and the guide adjustment bolt. Use the 3/8 x 1" bolt and a 3/8" hex nut to secure.

4. Select the proper sprocket arrangement for the spacing needed between plants. Look on page 2 or the chart on the side of your transplanter for the correct arrangement. For spacings using 11 tooth sprockets, extra chain links may be needed to lengthen the drive chain. These links are wired to the lift chain by the drive wheel. After finding the correct sprockets, run the long drive chain from the sprocket on the pocket chain shaft to the inside sprocket on the jackshaft of the direct drive wheel. The chain must go over the idler sprocket on the shoe brace and under the chain tightener sprocket as shown in the photo below.



5. Slide the red pipe spacer back onto the jackshaft. Insert the roll pin back into the second hole from the outside of the jackshaft. Slide the outside sprocket over the roll pin. Slide the drive chain coming from the drive wheel over the outside jackshaft sprocket. You may have to use your hand to push the chain tightener up to create enough slack in the chain. Insert the clip pin into the outside hole of the jackshaft.



6. Slide the outside chain guard onto the two pins and secure with clip pins.

Installation of Plant Stands

It is very important to know what row width will be used before installing the plant stands on multi-row transplanter. Follow the chart below.

- 42" Row Spacing - All Wide Plant Boxes
- 41" to 36" Row Spacing - Narrow Plant Boxes Inside
- 35" to 24" Row Spacing - One Wide Inside & Two Wide Outside
- 23" to 21" Row Spacing - One Narrow Inside & Two Wide Outside
- Less than 21" Row Spacing - Wide Outside Plant Boxes Only



1. Remove the long bolt between the uprights by the pocket chain. Do not lose the spacer between the uprights. Remove the outside cotter key in each axle.



2. Install the slotted mounting plates on both sides of the planter using the long bolt just removed. Do not tighten until the plant stand is fully assembled.



3. Slide plant stand onto the packing wheel axle and insert cotter key. Bend cotter key ends to keep in place.

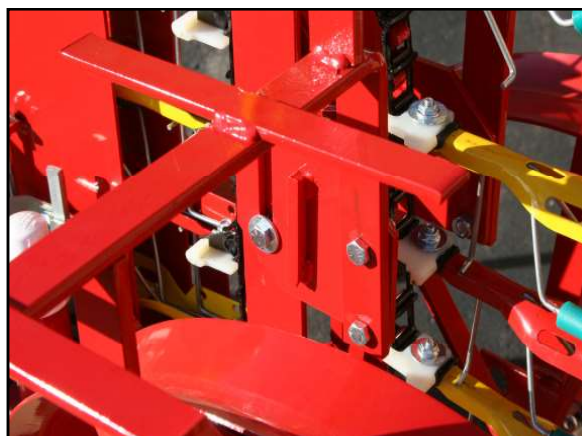

4. Use two 3/8 x 1" hex head bolts and two 3/8" nuts to attach plant stand frame to the slotted mounting bracket.



5. Attach the width adjustment plate with either the inside or outside hole depending on if you are using the wide (standard) plant boxes or the narrow with 3/8 x 1" hex head bolt and nut.

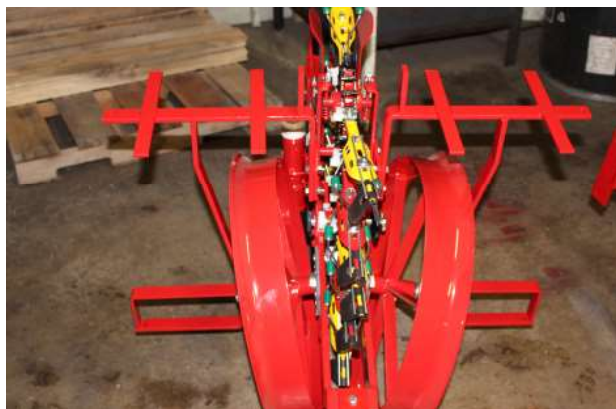

6. Install the plant boxes. These can be adjusted forward or backward for operator comfort.



Assembling the L-Shaped Seat Braces



1. Assemble the L-shaped seat brace by the chain guard. The sea brace mounts on the inside of the frame. The U-bolt mounts from the outside of the transplanter frame under the chain guard. Secure with 1/2" washers and 1/2" hex nuts over each threaded end.



2. The second L-shaped seat brace gets attached on the outside of the transplanter opposite the chain guard. The seat brace mounts on the outside of the frame with the U-bolt coming from the inside of the frame going outside through the seat brace. Secure with 1/2" washers and 1/2" hex nuts over each threaded end.

Mounting your Fiberglass or Cushion Seat

•Fiberglass Seats•



Fiberglass Seat - Turn your fiberglass seat over and remove any covers over the threaded studs. Take your green fiberglass seat bracket and mount it to the bottom of the seat with the side with the bend towards the front of the seat. Secure with four 1/4" hex nuts. Insert the 1/2 x 1-1/2 carriage bolt through the brace and then through the L-shaped seat bracket. Secure with a 1/2" washer and hex nut.

•Cushion Seats•

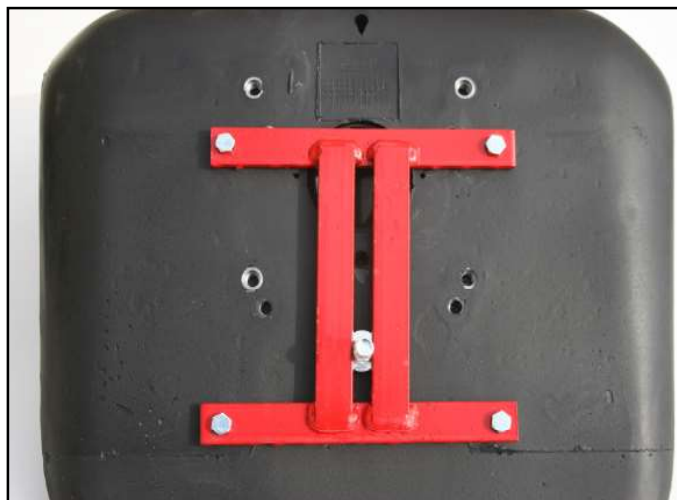

Cushion Seat - Slide the 1/2" x 1-1/2" carriage bolt through the bottom of the red seat bracket before mounting the seat bracket to the seat. After placing the carriage bolt through the seat bracket, place the seat bracket on the cushion seat. Secure with four 5/16" x 1" hex head bolts. Place the seat on the L-shaped seat bracket and secure with a 1/2" washer and hex nut.

Loose Pocket Assembly

If your Model 1000 was shipped in a crate, a pocket must be put on the empty attachment link.

The empty attachment link should be right at the top of the chain when the unit is shipped. If it is not, turn the drive wheel until the empty attachment link comes to the top.



Do NOT put #445 rubber gripper onto spring wires(#440) until pocket is assembled to attachment link.

Take the extra V-3 pocket that is wired onto unit and loosen the pocket bolt. Put pocket bolt through the attachment link. Make sure spacing bar stays under the head of the bolt. Place #375 water trip on the back of attachment link, then the 1/4" fender washer. Secure with 1/4" flange nut. After the bolt has been tightened, slide the top part of the #445 rubber gripper to the #440 wire.

Instructions for Direct Drive Clamps

The following instructions are for mounting the direct drive clamps to your Model 1000 unit. Although the pictures show the 2-1/2" clamps, use these instructions for any clamp style. They all mount the same way.



1. Insert a metal bushing from the inside of the frame. Put one of the 1/2 x 1-1/2" bolts through the bushing also from the inside.



2. Attach the clamp to the bolt in the **top** hole of the bottom set of large holes. Secure with a 1/2" hex nut.
3. If you have a Model 1000B-3 or 1000-2 follow directions below for one clamp side only. To mount safety bar on other clamp side, see page 11. In the **top** set of holes, place a 7/16 x 1-1/4" bolt through the top hole.

4. Slide the end link of the chain onto the bolt.
5. Secure the chain with a 3/8" washer and then a 7/16" hex nut. Make sure the nut is very tight.





6. Use the same instructions for the other side of the Direct Drive Wheel.

Note: The clamps may be reversed or fastened on the inside of the frame for narrow row spacings. Also, if other clamps are in the way, two lefts or two rights may be used. The lower holes on the clamps are for higher toolbars on older models or on tractors where 3-point hitch will not go low enough. Correct height of toolbar is 14" to center.

The Model 1000 unit can now be mounted to your 3-point hitch or toolbar. Following is a list of fasteners that you must use for various toolbars.

Toolbar Hardware List

- 2-1/2" or 2-1/4" Diamond toolbar - 7/8" V-bend U-bolt (2)
- 3" x 3" Flat Toolbar - 3/4" x 5" Hex bolts (4)
- 4" x 4" Flat Toolbar - 3/4" x 6" Hex bolts (4)
- 4" x 7" Toolbar - 3/4" x 9-1/2" Hex bolts (4)
- 5" x 7" Toolbar - 3/4" x 7" Hex bolts (4)
- 7" x 7" Toolbar - 3/4" x 9-1/2" (4)



Shown with clamps reversed

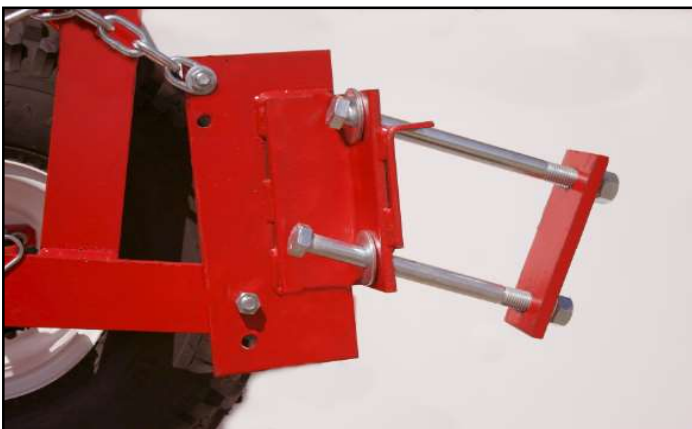

4 x 7 Toolbar Clamp. Use 2-3/4 x 9-1/2" hex bolts, 2-3/4" hex nuts and 2-3/4" washers.

Note: bent bracket on front of clamp

Model 1000B-3 Barrel Mounting & 3-Point Hitch Instructions



For B-3 Model, make sure the safety bar is properly installed!

To mount this safety bar, you must remove the 7/16 x 1-1/4" bolt from on side of the direct drive wheel.

1. Locate the special 2-1/2" stud in your bag of bolts and nuts.
2. Turn a 7/16" hex nut all the way onto the stud.
3. Put the 7/16" washer on the stud next to the nut.
4. Place the lift chain up against the washer.
5. Slide the stud through the hole on the Direct Drive frame and secure with a 7/16" hex nut.
6. Assemble another stud the same way and fasten it to the top hole of the front Direct Drive clamp.
7. Attach the red seat safety bar to the stud on your drive wheel. **The end with the hole must go on the clamp. The slotted end must go on the frame.** After the safety bar is attached, place the small clip pins through the small holes.

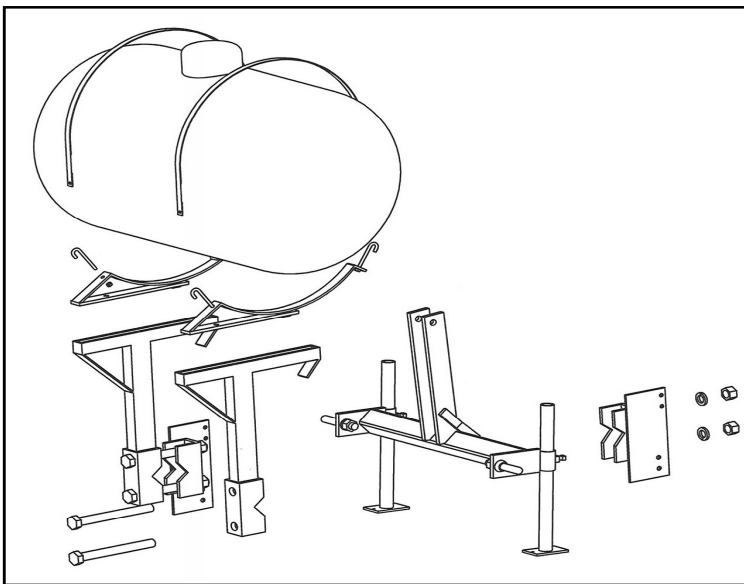

3-Point Hitch & Barrel Mounting

1. On the 3-point hitch, connect the Category I hitch pins through the holes on the outside of the hitch. Put the pins in through the outside and secure with the lock washer and hex nut included with the pin.
2. Slide the green pipe stands up through the pipes on the hitch, then tighten by turning the set screw.

Note: The following instructions will be easier with two people



3. Center the 3-point hitch toolbar with the clamps on your transplanter. Next, line up one of the barrel mounting brackets with the direct drive clamps. Secure using two 1 x 8-1/2 bolts and hex nuts. Do the same with the other barrel mounting bracket.



Side view of B-3 mountings



4. Bolt barrel hoops onto B-3 supports using 1/2 x 3" hex bolt with 1/2" lock nut. Note below: the hoops can be mounted in a forward or back position, depending on clearance that you need for the tractor fenders etc.



5. Screw in the nipple into the bottom of the tank.



6. Insert J-bolts into the four holes on the barrel hoops. It works best to thread 5/16" nut onto J-bolt before hooking up barrel hoops.



7. The 55 gallon poly tank can now be mounted on top of the barrel mountings. Use the four J-bolts and the galvanized straps to secure the barrel to the mountings.

A. Grease all fittings before the start of each day. Grease fittings are found:

1. On each packing wheel axle.
2. Upper pocket chain sprocket (Model 1000 only)
3. Direct drive tire hub (Direct Drive Units only)
4. On each nylon bushing on the pocket chain jackshaft.

B. Regulating Plant Depth

1. All operators should take care to see that the plants are placed well down in the pocket so the plant is held firmly.
2. The plant depth is regulated by the distance the root is extended out of the pocket.
3. To set the plants deeper, simply set the plant in the pocket with the roots further out than what is normally done. (See figure below)
4. If planting strawberries the axle must be raised up, allowing the transplanter unit to go deeper into the soil to cover the strawberry crowns.



V-3 Standard Plant Placement



Deeper Plant Placement

C. Pocket Chain Instructions

1. Make sure that bolts holding the upper sprocket on the pocket chain are not too tight. This will cause unnecessary friction on the unit and possible slippage on packing wheel drive transplanter. Simply loosen the wing nuts if the chain seems too tight.
2. Tighten the wing nuts equally by the top sprocket to keep the chain running level at all times.
3. If in row spacings of 20" or greater are needed, use only 6 pockets. You may remove every other pocket or leave them on. This gives the same speed or greater as a 12 pocket chain.

D. Adjusting or setting the #395R Round Point Shoe

Note: The shoe is preset at the factory for almost all situations.

Follow these instructions only if plants are leaning or in extreme wet or dry soil conditions.

1. Whenever any adjustments are made, be sure to get the shoe directly square and straight in front of the opening of the packing wheels. Make sure that the pockets will run through the middle of the shoe.
2. In loose dry soil, the shoe should be adjusted closer to the packing wheels. This can be done by adjusting the diagonal brace on the shoe.
3. In wet heavy soil, the shoe should be adjusted away from the packing wheels. Again, this can be done by adjusting the diagonal shoe brace.
4. Keep the shoe clean at all times. Do not allow dirt or trash to build up on the front or side of the shoe because this can cause too wide of a furrow that cannot be closed properly by the packing wheels. Poly covered shoes will eliminate this problem.

E. Water Valve Adjustment

1. For more water, make sure the valve is getting a full stroke by adjusting the #604 bracket on the pump rod. Make sure the valve does not over stroke. You should be able to lift the 604 rod 1/4-1/2" at the top of its stroke.
2. A broad range of adjustment can be achieved with the #603 water cam.
3. For wider spacings, the water cam may have to be raised so the water is on the plant. If the #603 is raised, be sure to raise the #604 water adjustment bracket accordingly and do not over stroke.

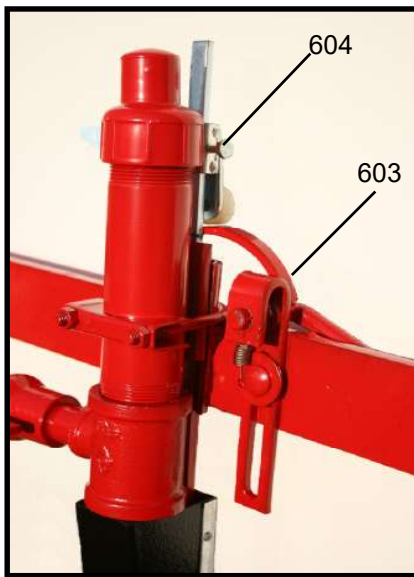

Example: At 20" row spacing, the #603 water cam should be adjusted nearly all the way up the slot. The #604 water adjustment must also be adjusted accordingly so a 1/2" remains on the 604 stroke.

4. Tilting the #603 water cam back towards the water trips on the pockets will create a longer stroke of water or more water before and after the plant.
5. Always empty the water out of the valve after quitting for the day. **Water freezing inside the valve will destroy the #610 and #612 balls inside the valve.**

F. Direct Drive Float Wheel Operation

1. Use only 4 to 5 pounds of air pressure in the Direct Drive Wheel during operation.



Wrong
Toolbar too high



Correct



Wrong
Toolbar too low

2. It is very important when starting to transplant, that the lift chains on the side of the Direct Drive Wheel are loose. See above "Correct" picture.
3. When lowering the transplanting unit into the ground, be sure that the frame members on the Direct Drive Wheel run parallel as is shown in the center picture. This is adjusted by the height of the hitch or toolbar (a pair of gauge wheels will eliminate adjustment of toolbar height).
4. Running the frame parallel will keep the lift chains loose allowing for proper floatation in the Direct Drive Wheel.
5. Running the frame members parallel and level will allow the packing wheels to run in the proper packing position.
6. Running the toolbar too low will tighten the back chains and cause the packing wheels to run too light and not pack the soil properly.
7. Running the toolbar too high will tighten the front lift chains and cause the Direct Drive Wheel to not run on the ground, especially through low spots.

Trouble Shooting

Important - Before attempting any of the following, make sure that the unit is running level or parallel to the ground. Do not run the front hitch or toolbar too far down or up. On all Model 1000 series units, make sure that the chains are loose on both sides of the arch bracket over the drive wheel. For all transplanter, make sure the soil is worked deep enough.

Problem

Solution

Packing wheels not packing properly

- A. Lengthen third arm on tractor to get float in hitch
- B. Hitch is too far down and needs to be lifted (lift chains are not loose)
- C. Clean off sides of shoe
- D. Work soil deeper
- E. Add weight to back of unit
- F. Poly shoes will eliminate soil building up on the outsides

Water leaks from top of water valve

- A. Check to see if the rubber nipple inside the top of the valve is in place and rounded.
- B. #610 ball inside the valve has collapsed and needs to be replaced.

Water leaks from bottom of water valve

- A. Rubber ball #612 on pin is broke and needs to be replaced
- B. The nylon nut on the bottom is broken and needs to be replaced

Water not uniform

- A. Make sure all the water trips on the pockets are in good shape and at even distances from the attachment link.
- B. Check to see that all springs on the water valve are in good working order.
- C. Water valve has dirt or residue build up that needs to be cleaned out

Water misses plants

•See water valve instructions on Page13.

Plants falling out of pocket

- A. Inspect the rubber grippers to make sure that they are not all stretched out.
- B. Tighten the L-bolts on the side of the guides.
- C. #482 pocket extensions may be needed if planting cell-type plants.
- D. Check bottom of guides to insure that the pocket is not releasing the plant too soon.

Plants on top of soil

- A. Cut back on water because the plants are floating up out of the shoe.
- B. Plants need to be pulled further out of the pocket to put them deeper.
- C. Too much loose soil is getting inside the shoe before the packing wheels can pack. Move shoe closer to packing wheels.
- D. A gap might be occurring by having the hitch too low causing the packing wheels to be up in the air or not being able to put enough pressure on the soil.
- E. Ground not worked deep enough causing the shoe to not go deep enough into the soil.

Plants leaning

- A. Need to put plant further in the pocket to keep it from hitting the bottom of the furrow.
- B. Possibility of needing a deeper shoe.
- C. May need #482 extensions to help support the cell of a plant coming from a tray.
- D. See Operating Instructions on Page 13 about adjusting the shoe.

Safety Precautions

1. Make sure tractor is stopped and in neutral with the transplanter lowered to the ground before getting on and off the unit.
2. No operator is allowed to be on the unit as it is raised and lowered.
3. No operator is allowed on the transplanter as it is transported to or from the field.
4. All operators must be seated before movement begins and remain seated until the transplanter is completely stopped.
5. Never leave the transplanter in the raised position.
6. Keep all shields and guards in place when operating the transplanter.
7. Never attempt repairs or maintenance while the transplanter is in motion.
8. Never put the tractor in reverse while the transplanter is on the ground.
9. Follow all safety instructions supplied by the tractor manufacturer to which the transplanter is mounted.

MACHINE IMPROVEMENTS

MECHANICAL TRANSPLANTER CO. IS ALWAYS STRIVING TO MAKE IMPROVEMENTS ON THEIR LINE OF EQUIPMENT. MECHANICAL TRANSPLANTER CO. RESERVES THE RIGHT TO MAKE IMPROVEMENTS AND CHANGES AT ANY TIME WITHOUT INCURRING OBLIGATIONS TO MAKE SUCH CHANGES OR ADDITIONS TO EQUIPMENT PREVIOUSLY SOLD.

Limited Warranty

Mechanical Transplanter Company warrants each item of new equipment manufactured by Mechanical to be free from defects in material and workmanship under normal use and service.

The obligation of Mechanical Transplanter Company under this LIMITED WARRANTY is limited to repairing or replacing as Mechanical may elect, and any parts that prove, in Mechanical's judgment, to be defective in material and workmanship within the first season's use or 45 consecutive days after initially placing equipment in operation, whichever occurs first. Any outside work or alterations without Mechanical's written approval will render the LIMITED WARRANTY void.

Mechanical's obligation specifically excludes any liability for consequential damages, such as loss of profits, delays, expenses, damage to goods or property used in connection with or processed in or by the product sold, or damage to the product sold from whatsoever cause, whether or not such loss is due to negligence of selling dealer of Mechanical Transplanter Company.

This limited warranty shall not apply to any item or machine which shall have been operated in a manner not recommended by the Company nor which shall have been repaired, altered, misused, damaged in an accident, neglected, tampered with or used in any way which in the Company's opinion adversely affects its performance and results.

No person is authorized to give any other warranties or to assume any other liability on behalf of Mechanical Transplanter Company, unless made in writing by Mechanical.

This limited warranty covers repair or replacement of Mechanical Transplanter Co. equipment only and does not cover crop loss, downtime, labor, damage to other equipment, etc.

This limited warranty does not apply to exterior finishes, tires, chain links, bearings, or any other items sold by Mechanical Transplanter Co., but warranted by the original manufacturer except to the extent of their individual manufacturer's warranty.

THIS LIMITED WARRANTY IS IN LIEU OF ALL OTHER WARRANTIES, EXPRESSED OR IMPLIED. WARRANTIES OF MERCHANTABILITY AND FITNESS FOR PARTICULAR PURPOSE ARE EXCLUDED, AS ARE ALL OTHER REPRESENTATIONS TO THE USER-PURCHASER, AND ALL OTHER OBLIGATIONS OR LIABILITIES, INCLUDING LIABILITY FOR INCIDENTAL AND CONSEQUENTIAL DAMAGES, ON THE PART OF MECHANICAL OR THE SELLER.

Mechanical Transplanter Co.

Model 1000 and 1000B-3

Operators Manual



Mechanical Transplanter Co., LLC
1150 Central Avenue • Holland, MI 49423-5230
Phone: 616-396-8738 • Fax: 616-396-3619
website: www.mechanicaltransplanter.com
e-mail: mtc@mechanicaltransplanter.com

Spacing Charts and Information

| SPACING CHART FOR DIRECT DRIVE UNIT W/ 12 POCKET CHAIN | | | | | | |
|---|---------------------------------|-------------------------------------|-----------------------|-----------------------|-------------------|-----------------|
| Sprocket on OUT-SIDE of Jackshaft | Sprocket on INSIDE of Jackshaft | Number of Teeth on Sprocket on Unit | | | | |
| | | 7 | 8 | 9 | 10 | 11 |
| 7 | 11 | 6" 15.2cm | 6-1/2" - 7" 17.8cm | 7-1/2" - 8" 20.3cm | 8-1/2" 21.6cm | 9" 22.8cm |
| 7 | 7 | 9" 22.8cm | 10-1/2" 26.7cm | 13" 33cm | 15" 38.1cm | 16" 40.6cm |
| 8 | 7 | 10-1/2" 26.7cm | 12-1/2" 31.7cm | 14" 35.5cm | 15" 38.1cm | 16" 40.6cm |
| 9 | 7 | 12" 30.5cm | 13-1/2" 34.3cm | 15" 38.1cm | 17" 43.2cm | 18-1/2" 47cm |
| 10 | 7 | 13" 33cm | 14" 35.5cm | 15-1/2" 39.4cm | 17-1/2" 44.5cm | 20-1/2" 52cm |
| 11 | 7 | 15" 38.1cm | 18" 45.7cm | | | |

Double any of the above spacings by using every other pocket (6 pocket).
Make sure HITCH and UNIT are level or parallel to the ground when planting.

Use for Model 1000

| DISC SPACING CHART FOR MODELS W/ DIRECT DRIVE | | | | | | | |
|--|---------------------------------|-------------------------------|-------------------------------------|--------|--------|--------|--------|
| Sprocket on OUTSIDE of Jackshaft | Sprocket on INSIDE of Jackshaft | Number of Pockets on the Disc | Number of Teeth on Sprocket by Disc | | | | |
| | | | 7 | 8 | 9 | 10 | 11 |
| 7 | 7 | 24 | | 2" | 2-1/4" | 2-1/2" | 2-3/4" |
| | | 16 | 3" | 3-1/4" | 3-1/2" | 4" | 4-1/2" |
| | | 12 | | 4-3/4" | 5-1/4" | 5-3/4" | 6-1/4" |
| 8 | 7 | 24 | | 2-1/2" | 3" | 3-1/4" | 3-1/2" |
| | | 16 | 3-1/2" | 3-3/4" | 4-1/4" | 4-1/2" | 5-1/4" |
| | | 12 | | 6" | 6-1/4" | 6-3/4" | 7" |
| 9 | 7 | 24 | 2-1/2" | 2-3/4" | 3-1/4" | 3-1/2" | 4" |
| | | 16 | 3-3/4" | 4-1/4" | 4-1/2" | 5" | 5-1/2" |
| | | 12 | 4-1/2" | 6-1/4" | 6-1/2" | 7-1/4" | 8" |
| 10 | 7 | 24 | 2-1/2" | 3" | 3-1/2" | 3-3/4" | 4-1/2" |
| | | 16 | 3-3/4" | 4-1/2" | 5-1/4" | | |
| | | 12 | 5-1/4" | 6" | 7" | 7-1/2" | 8-1/2" |
| 11 | 7 | 24 | 2-1/2" | 3" | 3-1/2" | 4-1/4" | 4-3/4" |
| | | 16 | 4" | 5" | 6" | | |
| | | 12 | 5-1/2" | 6-1/2" | 7-1/2" | 9" | 10" |

Use for Model 1000 with disc mounted pockets

Assembly Instructions

For Model 1000 Series Transplanters

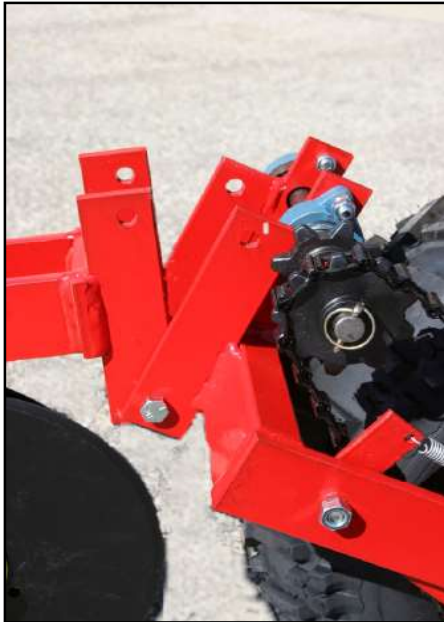

1. Bolt on the Direct Drive Float Wheel using the four 1/2 x 1-1/2 " bolts. Secure using the 1/2" hex nuts.



2. Remove the following parts from the direct drive wheel jackshaft: Clip pin, drive chain coming from the wheel, outside sprocket on jackshaft, and pipe spacer. Then remove the extra top hex nut located on the flange bearing.



3. Install the inside chain guard of the unit. Fasten front short tab to the top bolt on flange bearing from #2 photo with hex nut. The long tab attaches to the empty hole on the transplanter frame by the packing wheels. The guard must fit between the shoe brace and the guide adjustment bolt. Use the 3/8 x 1" bolt and a 3/8" hex nut to secure.

4. Select the proper sprocket arrangement for the spacing needed between plants. Look on page 2 or the chart on the side of your transplanter for the correct arrangement. For spacings using 11 tooth sprockets, extra chain links may be needed to lengthen the drive chain. These links are wired to the lift chain by the drive wheel. After finding the correct sprockets, run the long drive chain from the sprocket on the pocket chain shaft to the inside sprocket on the jackshaft of the direct drive wheel. The chain must go over the idler sprocket on the shoe brace and under the chain tightener sprocket as shown in the photo below.



5. Slide the red pipe spacer back onto the jackshaft. Insert the roll pin back into the second hole from the outside of the jackshaft. Slide the outside sprocket over the roll pin. Slide the drive chain coming from the drive wheel over the outside jackshaft sprocket. You may have to use your hand to push the chain tightener up to create enough slack in the chain. Insert the clip pin into the outside hole of the jackshaft.



6. Slide the outside chain guard onto the two pins and secure with clip pins.

Installation of Plant Stands

It is very important to know what row width will be used before installing the plant stands on multi-row transplanter. Follow the chart below.

- 42" Row Spacing - All Wide Plant Boxes
- 41" to 36" Row Spacing - Narrow Plant Boxes Inside
- 35" to 24" Row Spacing - One Wide Inside & Two Wide Outside
- 23" to 21" Row Spacing - One Narrow Inside & Two Wide Outside
- Less than 21" Row Spacing - Wide Outside Plant Boxes Only



1. Remove the long bolt between the uprights by the pocket chain. Do not lose the spacer between the uprights. Remove the outside cotter key in each axle.



2. Install the slotted mounting plates on both sides of the planter using the long bolt just removed. Do not tighten until the plant stand is fully assembled.



3. Slide plant stand onto the packing wheel axle and insert cotter key. Bend cotter key ends to keep in place.

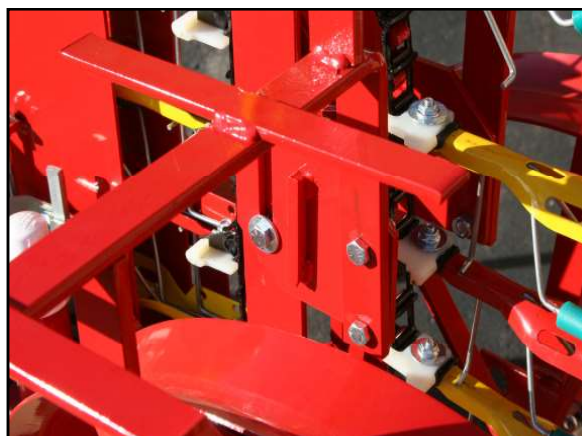

4. Use two 3/8 x 1" hex head bolts and two 3/8" nuts to attach plant stand frame to the slotted mounting bracket.



5. Attach the width adjustment plate with either the inside or outside hole depending on if you are using the wide (standard) plant boxes or the narrow with 3/8 x 1" hex head bolt and nut.

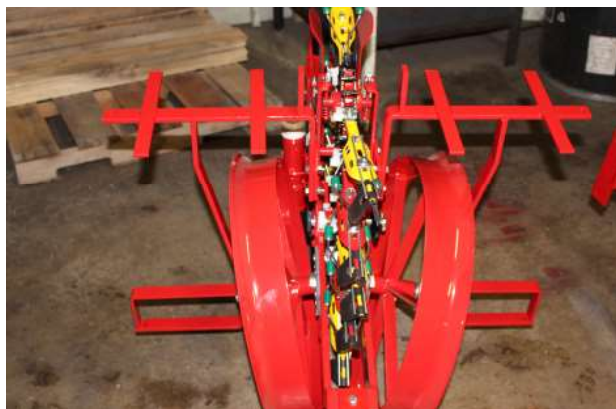

6. Install the plant boxes. These can be adjusted forward or backward for operator comfort.



Assembling the L-Shaped Seat Braces



1. Assemble the L-shaped seat brace by the chain guard. The sea brace mounts on the inside of the frame. The U-bolt mounts from the outside of the transplanter frame under the chain guard. Secure with 1/2" washers and 1/2" hex nuts over each threaded end.



2. The second L-shaped seat brace gets attached on the outside of the transplanter opposite the chain guard. The seat brace mounts on the outside of the frame with the U-bolt coming from the inside of the frame going outside through the seat brace. Secure with 1/2" washers and 1/2" hex nuts over each threaded end.

Mounting your Fiberglass or Cushion Seat

•Fiberglass Seats•



Fiberglass Seat - Turn your fiberglass seat over and remove any covers over the threaded studs. Take your green fiberglass seat bracket and mount it to the bottom of the seat with the side with the bend towards the front of the seat. Secure with four 1/4" hex nuts. Insert the 1/2 x 1-1/2 carriage bolt through the brace and then through the L-shaped seat bracket. Secure with a 1/2" washer and hex nut.

•Cushion Seats•

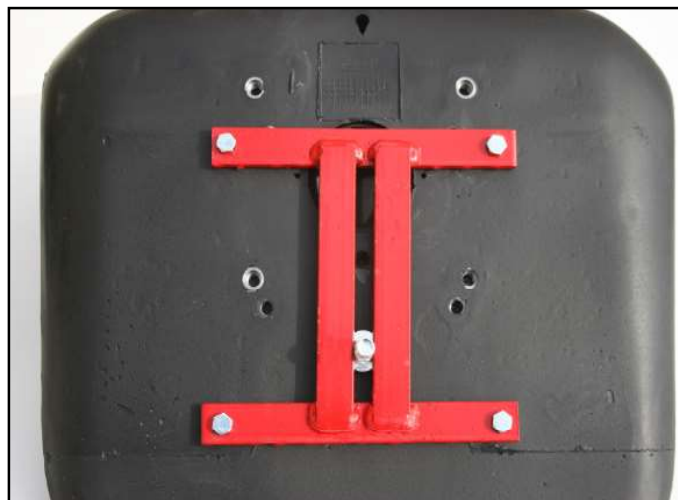

Cushion Seat - Slide the 1/2" x 1-1/2" carriage bolt through the bottom of the red seat bracket before mounting the seat bracket to the seat. After placing the carriage bolt through the seat bracket, place the seat on the L-shaped seat bracket and secure with a 1/2" washer and hex nut.

Loose Pocket Assembly

If your Model 1000 was shipped in a crate, a pocket must be put on the empty attachment link.

The empty attachment link should be right at the top of the chain when the unit is shipped. If it is not, turn the drive wheel until the empty attachment link comes to the top.



Do NOT put #445 rubber gripper onto spring wires(#440) until pocket is assembled to attachment link.

Take the extra V-3 pocket that is wired onto unit and loosen the pocket bolt. Put pocket bolt through the attachment link. Make sure spacing bar stays under the head of the bolt. Place #375 water trip on the back of attachment link, then the 1/4" fender washer. Secure with 1/4" flange nut. After the bolt has been tightened, slide the top part of the #445 rubber gripper to the #440 wire.

Instructions for Direct Drive Clamps

The following instructions are for mounting the direct drive clamps to your Model 1000 unit. Although the pictures show the 2-1/2" clamps, use these instructions for any clamp style. They all mount the same way.



1. Insert a metal bushing from the inside of the frame. Put one of the 1/2 x 1-1/2" bolts through the bushing also from the inside.

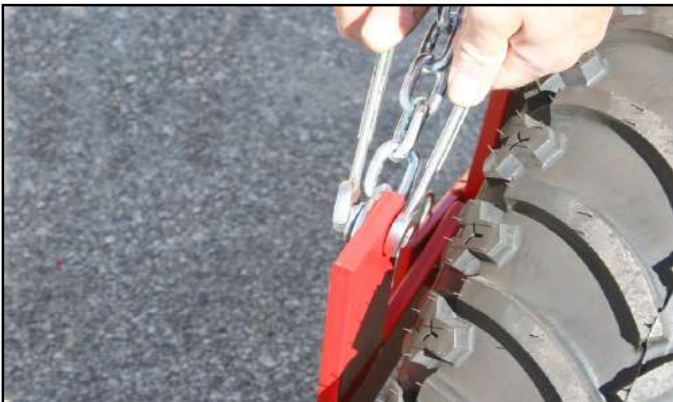

2. Attach the clamp to the bolt in the **top** hole of the bottom set of large holes. Secure with a 1/2" hex nut.
3. If you have a Model 1000B-3 or 1000-2 follow directions below for one clamp side only. To mount safety bar on other clamp side, see page 11. In the **top** set of holes, place a 7/16 x 1-1/4" bolt through the top hole.

4. Slide the end link of the chain onto the bolt.
5. Secure the chain with a 3/8" washer and then a 7/16" hex nut. Make sure the nut is very tight.





6. Use the same instructions for the other side of the Direct Drive Wheel.

Note: The clamps may be reversed or fastened on the inside of the frame for narrow row spacings. Also, if other clamps are in the way, two lefts or two rights may be used. The lower holes on the clamps are for higher toolbars on older models or on tractors where 3-point hitch will not go low enough. Correct height of toolbar is 14" to center.

The Model 1000 unit can now be mounted to your 3-point hitch or toolbar. Following is a list of fasteners that you must use for various toolbars.

Toolbar Hardware List

- 2-1/2" or 2-1/4" Diamond toolbar - 7/8" V-bend U-bolt (2)
- 3" x 3" Flat Toolbar - 3/4" x 5" Hex bolts (4)
- 4" x 4" Flat Toolbar - 3/4" x 6" Hex bolts (4)
- 4" x 7" Toolbar - 3/4" x 9-1/2" Hex bolts (4)
- 5" x 7" Toolbar - 3/4" x 7" Hex bolts (4)
- 7" x 7" Toolbar - 3/4" x 9-1/2" (4)



Shown with clamps reversed

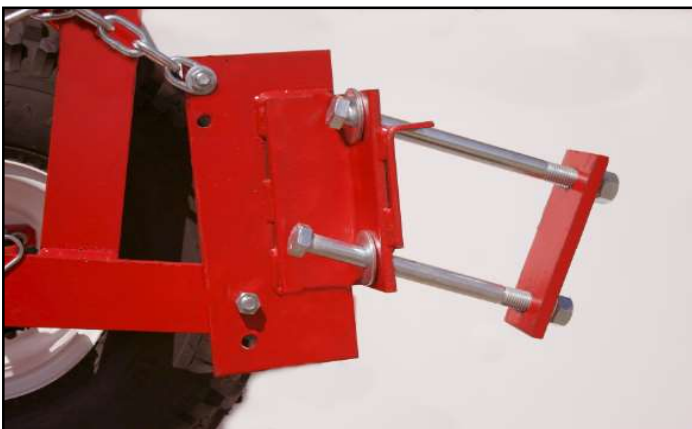

4 x 7 Toolbar Clamp. Use 2-3/4 x 9-1/2" hex bolts, 2-3/4" hex nuts and 2-3/4" washers.

Note: bent bracket on front of clamp

Model 1000B-3 Barrel Mounting & 3-Point Hitch Instructions



For B-3 Model, make sure the safety bar is properly installed!

To mount this safety bar, you must remove the 7/16 x 1-1/4" bolt from on side of the direct drive wheel.

1. Locate the special 2-1/2" stud in your bag of bolts and nuts.
2. Turn a 7/16" hex nut all the way onto the stud.
3. Put the 7/16" washer on the stud next to the nut.
4. Place the lift chain up against the washer.
5. Slide the stud through the hole on the Direct Drive frame and secure with a 7/16" hex nut.
6. Assemble another stud the same way and fasten it to the top hole of the front Direct Drive clamp.
7. Attach the red seat safety bar to the stud on your drive wheel. **The end with the hole must go on the clamp. The slotted end must go on the frame.** After the safety bar is attached, place the small clip pins through the small holes.

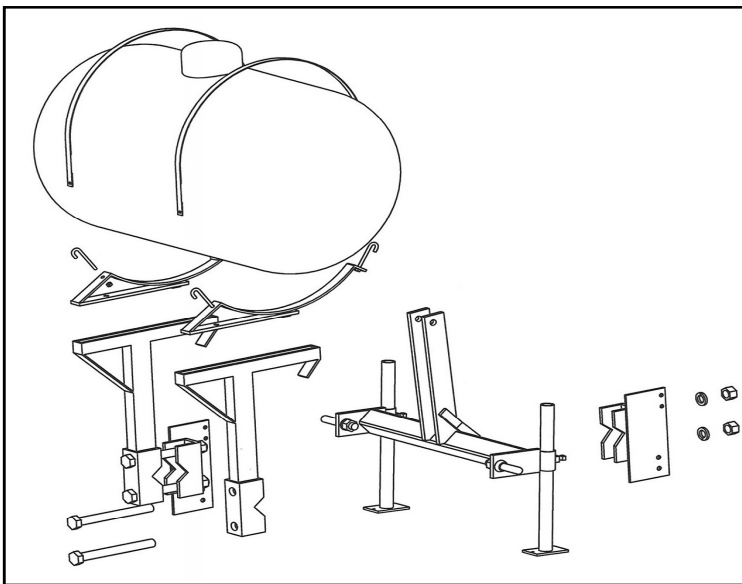

3-Point Hitch & Barrel Mounting

1. On the 3-point hitch, connect the Category I hitch pins through the holes on the outside of the hitch. Put the pins in through the outside and secure with the lock washer and hex nut included with the pin.
2. Slide the green pipe stands up through the pipes on the hitch, then tighten by turning the set screw.

Note: The following instructions will be easier with two people



3. Center the 3-point hitch toolbar with the clamps on your transplanter. Next, line up one of the barrel mounting brackets with the direct drive clamps. Secure using two 1 x 8-1/2 bolts and hex nuts. Do the same with the other barrel mounting bracket.



Side view of B-3 mountings



4. Bolt barrel hoops onto B-3 supports using 1/2 x 3" hex bolt with 1/2" lock nut. Note below: the hoops can be mounted in a forward or back position, depending on clearance that you need for the tractor fenders etc.



5. Screw in the nipple into the bottom of the tank.



6. Insert J-bolts into the four holes on the barrel hoops. It works best to thread 5/16" nut onto J-bolt before hooking up barrel hoops.



7. The 55 gallon poly tank can now be mounted on top of the barrel mountings. Use the four J-bolts and the galvanized straps to secure the barrel to the mountings.

A. Grease all fittings before the start of each day. Grease fittings are found:

1. On each packing wheel axle.
2. Upper pocket chain sprocket (Model 1000 only)
3. Direct drive tire hub (Direct Drive Units only)
4. On each nylon bushing on the pocket chain jackshaft.

B. Regulating Plant Depth

1. All operators should take care to see that the plants are placed well down in the pocket so the plant is held firmly.
2. The plant depth is regulated by the distance the root is extended out of the pocket.
3. To set the plants deeper, simply set the plant in the pocket with the roots further out than what is normally done. (See figure below)
4. If planting strawberries the axle must be raised up, allowing the transplanter unit to go deeper into the soil to cover the strawberry crowns.



V-3 Standard Plant Placement



Deeper Plant Placement

C. Pocket Chain Instructions

1. Make sure that bolts holding the upper sprocket on the pocket chain are not too tight. This will cause unnecessary friction on the unit and possible slippage on packing wheel drive transplanter. Simply loosen the wing nuts if the chain seems too tight.
2. Tighten the wing nuts equally by the top sprocket to keep the chain running level at all times.
3. If in row spacings of 20" or greater are needed, use only 6 pockets. You may remove every other pocket or leave them on. This gives the same speed or greater as a 12 pocket chain.

D. Adjusting or setting the #395R Round Point Shoe

Note: The shoe is preset at the factory for almost all situations.

Follow these instructions only if plants are leaning or in extreme wet or dry soil conditions.

1. Whenever any adjustments are made, be sure to get the shoe directly square and straight in front of the opening of the packing wheels. Make sure that the pockets will run through the middle of the shoe.
2. In loose dry soil, the shoe should be adjusted closer to the packing wheels. This can be done by adjusting the diagonal brace on the shoe.
3. In wet heavy soil, the shoe should be adjusted away from the packing wheels. Again, this can be done by adjusting the diagonal shoe brace.
4. Keep the shoe clean at all times. Do not allow dirt or trash to build up on the front or side of the shoe because this can cause too wide of a furrow that cannot be closed properly by the packing wheels. Poly covered shoes will eliminate this problem.

E. Water Valve Adjustment

1. For more water, make sure the valve is getting a full stroke by adjusting the #604 bracket on the pump rod. Make sure the valve does not over stroke. You should be able to lift the 604 rod 1/4-1/2" at the top of its stroke.
2. A broad range of adjustment can be achieved with the #603 water cam.
3. For wider spacings, the water cam may have to be raised so the water is on the plant. If the #603 is raised, be sure to raise the #604 water adjustment bracket accordingly and do not over stroke.

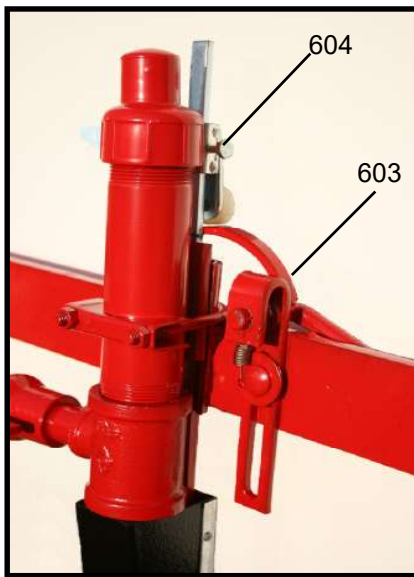

Example: At 20" row spacing, the #603 water cam should be adjusted nearly all the way up the slot. The #604 water adjustment must also be adjusted accordingly so a 1/2" remains on the 604 stroke.

4. Tilting the #603 water cam back towards the water trips on the pockets will create a longer stroke of water or more water before and after the plant.
5. Always empty the water out of the valve after quitting for the day. **Water freezing inside the valve will destroy the #610 and #612 balls inside the valve.**

F. Direct Drive Float Wheel Operation

1. Use only 4 to 5 pounds of air pressure in the Direct Drive Wheel during operation.



Wrong
Toolbar too high



Correct



Wrong
Toolbar too low

2. It is very important when starting to transplant, that the lift chains on the side of the Direct Drive Wheel are loose. See above "Correct" picture.
3. When lowering the transplanting unit into the ground, be sure that the frame members on the Direct Drive Wheel run parallel as is shown in the center picture. This is adjusted by the height of the hitch or toolbar (a pair of gauge wheels will eliminate adjustment of toolbar height).
4. Running the frame parallel will keep the lift chains loose allowing for proper floatation in the Direct Drive Wheel.
5. Running the frame members parallel and level will allow the packing wheels to run in the proper packing position.
6. Running the toolbar too low will tighten the back chains and cause the packing wheels to run too light and not pack the soil properly.
7. Running the toolbar too high will tighten the front lift chains and cause the Direct Drive Wheel to not run on the ground, especially through low spots.

Trouble Shooting

Important - Before attempting any of the following, make sure that the unit is running level or parallel to the ground. Do not run the front hitch or toolbar too far down or up. On all Model 1000 series units, make sure that the chains are loose on both sides of the arch bracket over the drive wheel. For all transplanter, make sure the soil is worked deep enough.

Problem

Solution

Packing wheels not packing properly

- A. Lengthen third arm on tractor to get float in hitch
- B. Hitch is too far down and needs to be lifted (lift chains are not loose)
- C. Clean off sides of shoe
- D. Work soil deeper
- E. Add weight to back of unit
- F. Poly shoes will eliminate soil building up on the outsides

Water leaks from top of water valve

- A. Check to see if the rubber nipple inside the top of the valve is in place and rounded.
- B. #610 ball inside the valve has collapsed and needs to be replaced.

Water leaks from bottom of water valve

- A. Rubber ball #612 on pin is broke and needs to be replaced
- B. The nylon nut on the bottom is broken and needs to be replaced

Water not uniform

- A. Make sure all the water trips on the pockets are in good shape and at even distances from the attachment link.
- B. Check to see that all springs on the water valve are in good working order.
- C. Water valve has dirt or residue build up that needs to be cleaned out

Water misses plants

•See water valve instructions on Page13.

Plants falling out of pocket

- A. Inspect the rubber grippers to make sure that they are not all stretched out.
- B. Tighten the L-bolts on the side of the guides.
- C. #482 pocket extensions may be needed if planting cell-type plants.
- D. Check bottom of guides to insure that the pocket is not releasing the plant too soon.

Plants on top of soil

- A. Cut back on water because the plants are floating up out of the shoe.
- B. Plants need to be pulled further out of the pocket to put them deeper.
- C. Too much loose soil is getting inside the shoe before the packing wheels can pack. Move shoe closer to packing wheels.
- D. A gap might be occurring by having the hitch too low causing the packing wheels to be up in the air or not being able to put enough pressure on the soil.
- E. Ground not worked deep enough causing the shoe to not go deep enough into the soil.

Plants leaning

- A. Need to put plant further in the pocket to keep it from hitting the bottom of the furrow.
- B. Possibility of needing a deeper shoe.
- C. May need #482 extensions to help support the cell of a plant coming from a tray.
- D. See Operating Instructions on Page 13 about adjusting the shoe.

Safety Precautions

1. Make sure tractor is stopped and in neutral with the transplanter lowered to the ground before getting on and off the unit.
2. No operator is allowed to be on the unit as it is raised and lowered.
3. No operator is allowed on the transplanter as it is transported to or from the field.
4. All operators must be seated before movement begins and remain seated until the transplanter is completely stopped.
5. Never leave the transplanter in the raised position.
6. Keep all shields and guards in place when operating the transplanter.
7. Never attempt repairs or maintenance while the transplanter is in motion.
8. Never put the tractor in reverse while the transplanter is on the ground.
9. Follow all safety instructions supplied by the tractor manufacturer to which the transplanter is mounted.

MACHINE IMPROVEMENTS

MECHANICAL TRANSPLANTER CO. IS ALWAYS STRIVING TO MAKE IMPROVEMENTS ON THEIR LINE OF EQUIPMENT. MECHANICAL TRANSPLANTER CO. RESERVES THE RIGHT TO MAKE IMPROVEMENTS AND CHANGES AT ANY TIME WITHOUT INCURRING OBLIGATIONS TO MAKE SUCH CHANGES OR ADDITIONS TO EQUIPMENT PREVIOUSLY SOLD.

Limited Warranty

Mechanical Transplanter Company warrants each item of new equipment manufactured by Mechanical to be free from defects in material and workmanship under normal use and service.

The obligation of Mechanical Transplanter Company under this LIMITED WARRANTY is limited to repairing or replacing as Mechanical may elect, and any parts that prove, in Mechanical's judgment, to be defective in material and workmanship within the first season's use or 45 consecutive days after initially placing equipment in operation, whichever occurs first. Any outside work or alterations without Mechanical's written approval will render the LIMITED WARRANTY void.

Mechanical's obligation specifically excludes any liability for consequential damages, such as loss of profits, delays, expenses, damage to goods or property used in connection with or processed in or by the product sold, or damage to the product sold from whatsoever cause, whether or not such loss is due to negligence of selling dealer of Mechanical Transplanter Company.

This limited warranty shall not apply to any item or machine which shall have been operated in a manner not recommended by the Company nor which shall have been repaired, altered, misused, damaged in an accident, neglected, tampered with or used in any way which in the Company's opinion adversely affects its performance and results.

No person is authorized to give any other warranties or to assume any other liability on behalf of Mechanical Transplanter Company, unless made in writing by Mechanical.

This limited warranty covers repair or replacement of Mechanical Transplanter Co. equipment only and does not cover crop loss, downtime, labor, damage to other equipment, etc.

This limited warranty does not apply to exterior finishes, tires, chain links, bearings, or any other items sold by Mechanical Transplanter Co., but warranted by the original manufacturer except to the extent of their individual manufacturer's warranty.

THIS LIMITED WARRANTY IS IN LIEU OF ALL OTHER WARRANTIES, EXPRESSED OR IMPLIED. WARRANTIES OF MERCHANTABILITY AND FITNESS FOR PARTICULAR PURPOSE ARE EXCLUDED, AS ARE ALL OTHER REPRESENTATIONS TO THE USER-PURCHASER, AND ALL OTHER OBLIGATIONS OR LIABILITIES, INCLUDING LIABILITY FOR INCIDENTAL AND CONSEQUENTIAL DAMAGES, ON THE PART OF MECHANICAL OR THE SELLER.

Mechanical Transplanter Co.

Model 1000 and 1000B-3

Operators Manual



Mechanical Transplanter Co., LLC
1150 Central Avenue • Holland, MI 49423-5230
Phone: 616-396-8738 • Fax: 616-396-3619
website: www.mechanicaltransplanter.com
e-mail: mtc@mechanicaltransplanter.com

Spacing Charts and Information

| SPACING CHART FOR DIRECT DRIVE UNIT W/ 12 POCKET CHAIN | | | | | | |
|---|---------------------------------|-------------------------------------|-----------------------|-----------------------|-------------------|-----------------|
| Sprocket on OUT-SIDE of Jackshaft | Sprocket on INSIDE of Jackshaft | Number of Teeth on Sprocket on Unit | | | | |
| | | 7 | 8 | 9 | 10 | 11 |
| 7 | 11 | 6" 15.2cm | 6-1/2" - 7" 17.8cm | 7-1/2" - 8" 20.3cm | 8-1/2" 21.6cm | 9" 22.8cm |
| 7 | 7 | 9" 22.8cm | 10-1/2" 26.7cm | 13" 33cm | 15" 38.1cm | 16" 40.6cm |
| 8 | 7 | 10-1/2" 26.7cm | 12-1/2" 31.7cm | 14" 35.5cm | 15" 38.1cm | 16" 40.6cm |
| 9 | 7 | 12" 30.5cm | 13-1/2" 34.3cm | 15" 38.1cm | 17" 43.2cm | 18-1/2" 47cm |
| 10 | 7 | 13" 33cm | 14" 35.5cm | 15-1/2" 39.4cm | 17-1/2" 44.5cm | 20-1/2" 52cm |
| 11 | 7 | 15" 38.1cm | 18" 45.7cm | | | |

Double any of the above spacings by using every other pocket (6 pocket).
Make sure HITCH and UNIT are level or parallel to the ground when planting.

Use for Model 1000

| DISC SPACING CHART FOR MODELS W/ DIRECT DRIVE | | | | | | | |
|--|---------------------------------|-------------------------------|-------------------------------------|--------|--------|--------|--------|
| Sprocket on OUTSIDE of Jackshaft | Sprocket on INSIDE of Jackshaft | Number of Pockets on the Disc | Number of Teeth on Sprocket by Disc | | | | |
| | | | 7 | 8 | 9 | 10 | 11 |
| 7 | 7 | 24 | | 2" | 2-1/4" | 2-1/2" | 2-3/4" |
| | | 16 | 3" | 3-1/4" | 3-1/2" | 4" | 4-1/2" |
| | | 12 | | 4-3/4" | 5-1/4" | 5-3/4" | 6-1/4" |
| 8 | 7 | 24 | | 2-1/2" | 3" | 3-1/4" | 3-1/2" |
| | | 16 | 3-1/2" | 3-3/4" | 4-1/4" | 4-1/2" | 5-1/4" |
| | | 12 | | 6" | 6-1/4" | 6-3/4" | 7" |
| 9 | 7 | 24 | 2-1/2" | 2-3/4" | 3-1/4" | 3-1/2" | 4" |
| | | 16 | 3-3/4" | 4-1/4" | 4-1/2" | 5" | 5-1/2" |
| | | 12 | 4-1/2" | 6-1/4" | 6-1/2" | 7-1/4" | 8" |
| 10 | 7 | 24 | 2-1/2" | 3" | 3-1/2" | 3-3/4" | 4-1/2" |
| | | 16 | 3-3/4" | 4-1/2" | 5-1/4" | | |
| | | 12 | 5-1/4" | 6" | 7" | 7-1/2" | 8-1/2" |
| 11 | 7 | 24 | 2-1/2" | 3" | 3-1/2" | 4-1/4" | 4-3/4" |
| | | 16 | 4" | 5" | 6" | | |
| | | 12 | 5-1/2" | 6-1/2" | 7-1/2" | 9" | 10" |

Use for Model 1000 with disc mounted pockets

Assembly Instructions

For Model 1000 Series Transplanters

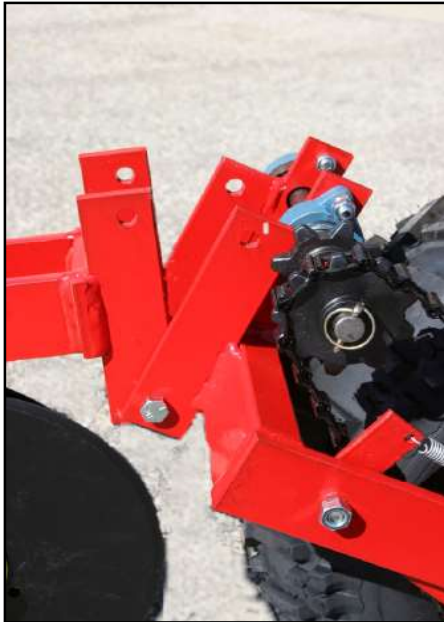

1. Bolt on the Direct Drive Float Wheel using the four 1/2 x 1-1/2 " bolts. Secure using the 1/2" hex nuts.



2. Remove the following parts from the direct drive wheel jackshaft: Clip pin, drive chain coming from the wheel, outside sprocket on jackshaft, and pipe spacer. Then remove the extra top hex nut located on the flange bearing.



3. Install the inside chain guard of the unit. Fasten front short tab to the top bolt on flange bearing from #2 photo with hex nut. The long tab attaches to the empty hole on the transplanter frame by the packing wheels. The guard must fit between the shoe brace and the guide adjustment bolt. Use the 3/8 x 1" bolt and a 3/8" hex nut to secure.

4. Select the proper sprocket arrangement for the spacing needed between plants. Look on page 2 or the chart on the side of your transplanter for the correct arrangement. For spacings using 11 tooth sprockets, extra chain links may be needed to lengthen the drive chain. These links are wired to the lift chain by the drive wheel. After finding the correct sprockets, run the long drive chain from the sprocket on the pocket chain shaft to the inside sprocket on the jackshaft of the direct drive wheel. The chain must go over the idler sprocket on the shoe brace and under the chain tightener sprocket as shown in the photo below.



5. Slide the red pipe spacer back onto the jackshaft. Insert the roll pin back into the second hole from the outside of the jackshaft. Slide the outside sprocket over the roll pin. Slide the drive chain coming from the drive wheel over the outside jackshaft sprocket. You may have to use your hand to push the chain tightener up to create enough slack in the chain. Insert the clip pin into the outside hole of the jackshaft.



6. Slide the outside chain guard onto the two pins and secure with clip pins.

Installation of Plant Stands

It is very important to know what row width will be used before installing the plant stands on multi-row transplanter. Follow the chart below.

- 42" Row Spacing - All Wide Plant Boxes
- 41" to 36" Row Spacing - Narrow Plant Boxes Inside
- 35" to 24" Row Spacing - One Wide Inside & Two Wide Outside
- 23" to 21" Row Spacing - One Narrow Inside & Two Wide Outside
- Less than 21" Row Spacing - Wide Outside Plant Boxes Only



1. Remove the long bolt between the uprights by the pocket chain. Do not lose the spacer between the uprights. Remove the outside cotter key in each axle.



2. Install the slotted mounting plates on both sides of the planter using the long bolt just removed. Do not tighten until the plant stand is fully assembled.



3. Slide plant stand onto the packing wheel axle and insert cotter key. Bend cotter key ends to keep in place.

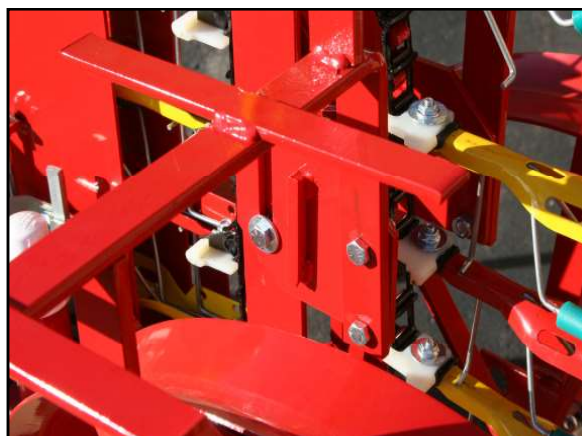

4. Use two 3/8 x 1" hex head bolts and two 3/8" nuts to attach plant stand frame to the slotted mounting bracket.



5. Attach the width adjustment plate with either the inside or outside hole depending on if you are using the wide (standard) plant boxes or the narrow with 3/8 x 1" hex head bolt and nut.

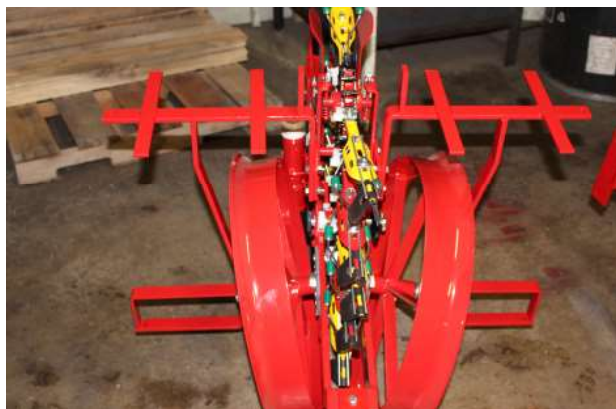

6. Install the plant boxes. These can be adjusted forward or backward for operator comfort.



Assembling the L-Shaped Seat Braces



1. Assemble the L-shaped seat brace by the chain guard. The sea brace mounts on the inside of the frame. The U-bolt mounts from the outside of the transplanter frame under the chain guard. Secure with 1/2" washers and 1/2" hex nuts over each threaded end.



2. The second L-shaped seat brace gets attached on the outside of the transplanter opposite the chain guard. The seat brace mounts on the outside of the frame with the U-bolt coming from the inside of the frame going outside through the seat brace. Secure with 1/2" washers and 1/2" hex nuts over each threaded end.

Mounting your Fiberglass or Cushion Seat

•Fiberglass Seats•



Fiberglass Seat - Turn your fiberglass seat over and remove any covers over the threaded studs. Take your green fiberglass seat bracket and mount it to the bottom of the seat with the side with the bend towards the front of the seat. Secure with four 1/4" hex nuts. Insert the 1/2 x 1-1/2 carriage bolt through the brace and then through the L-shaped seat bracket. Secure with a 1/2" washer and hex nut.

•Cushion Seats•

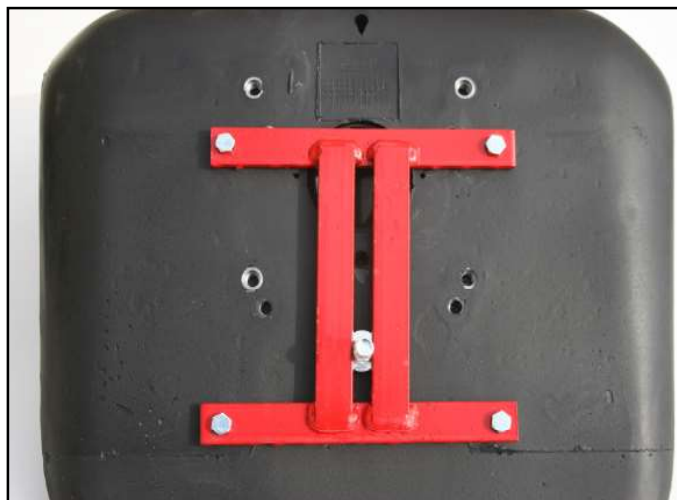

Cushion Seat - Slide the 1/2" x 1-1/2" carriage bolt through the bottom of the red seat bracket before mounting the seat bracket to the seat. After placing the carriage bolt through the seat bracket, place the seat bracket on the cushion seat. Secure with four 5/16" x 1" hex head bolts. Place the seat on the L-shaped seat bracket and secure with a 1/2" washer and hex nut.

Loose Pocket Assembly

If your Model 1000 was shipped in a crate, a pocket must be put on the empty attachment link.

The empty attachment link should be right at the top of the chain when the unit is shipped. If it is not, turn the drive wheel until the empty attachment link comes to the top.



Do NOT put #445 rubber gripper onto spring wires(#440) until pocket is assembled to attachment link.

Take the extra V-3 pocket that is wired onto unit and loosen the pocket bolt. Put pocket bolt through the attachment link. Make sure spacing bar stays under the head of the bolt. Place #375 water trip on the back of attachment link, then the 1/4" fender washer. Secure with 1/4" flange nut. After the bolt has been tightened, slide the top part of the #445 rubber gripper to the #440 wire.

Instructions for Direct Drive Clamps

The following instructions are for mounting the direct drive clamps to your Model 1000 unit. Although the pictures show the 2-1/2" clamps, use these instructions for any clamp style. They all mount the same way.



1. Insert a metal bushing from the inside of the frame. Put one of the 1/2 x 1-1/2" bolts through the bushing also from the inside.



2. Attach the clamp to the bolt in the **top** hole of the bottom set of large holes. Secure with a 1/2" hex nut.
3. If you have a Model 1000B-3 or 1000-2 follow directions below for one clamp side only. To mount safety bar on other clamp side, see page 11. In the **top** set of holes, place a 7/16 x 1-1/4" bolt through the top hole.

4. Slide the end link of the chain onto the bolt.
5. Secure the chain with a 3/8" washer and then a 7/16" hex nut. Make sure the nut is very tight.





6. Use the same instructions for the other side of the Direct Drive Wheel.

Note: The clamps may be reversed or fastened on the inside of the frame for narrow row spacings. Also, if other clamps are in the way, two lefts or two rights may be used. The lower holes on the clamps are for higher toolbars on older models or on tractors where 3-point hitch will not go low enough. Correct height of toolbar is 14" to center.

The Model 1000 unit can now be mounted to your 3-point hitch or toolbar. Following is a list of fasteners that you must use for various toolbars.

Toolbar Hardware List

- 2-1/2" or 2-1/4" Diamond toolbar - 7/8" V-bend U-bolt (2)
- 3" x 3" Flat Toolbar - 3/4" x 5" Hex bolts (4)
- 4" x 4" Flat Toolbar - 3/4" x 6" Hex bolts (4)
- 4" x 7" Toolbar - 3/4" x 9-1/2" Hex bolts (4)
- 5" x 7" Toolbar - 3/4" x 7" Hex bolts (4)
- 7" x 7" Toolbar - 3/4" x 9-1/2" (4)



Shown with clamps reversed

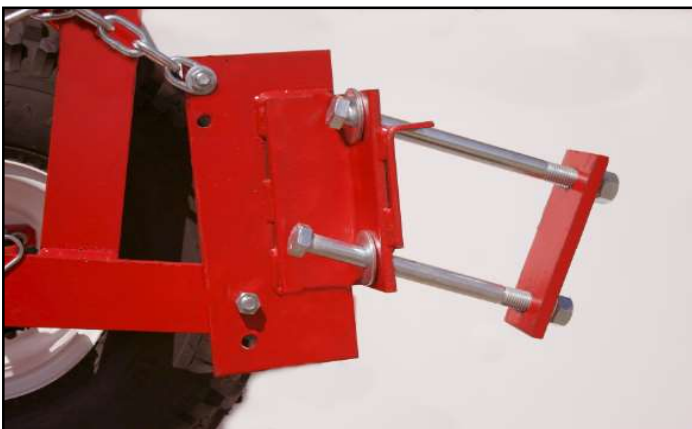

4 x 7 Toolbar Clamp. Use 2-3/4 x 9-1/2" hex bolts, 2-3/4" hex nuts and 2-3/4" washers.

Note: bent bracket on front of clamp

Model 1000B-3 Barrel Mounting & 3-Point Hitch Instructions



For B-3 Model, make sure the safety bar is properly installed!

To mount this safety bar, you must remove the 7/16 x 1-1/4" bolt from on side of the direct drive wheel.

1. Locate the special 2-1/2" stud in your bag of bolts and nuts.
2. Turn a 7/16" hex nut all the way onto the stud.
3. Put the 7/16" washer on the stud next to the nut.
4. Place the lift chain up against the washer.
5. Slide the stud through the hole on the Direct Drive frame and secure with a 7/16" hex nut.
6. Assemble another stud the same way and fasten it to the top hole of the front Direct Drive clamp.
7. Attach the red seat safety bar to the stud on your drive wheel. **The end with the hole must go on the clamp. The slotted end must go on the frame.** After the safety bar is attached, place the small clip pins through the small holes.

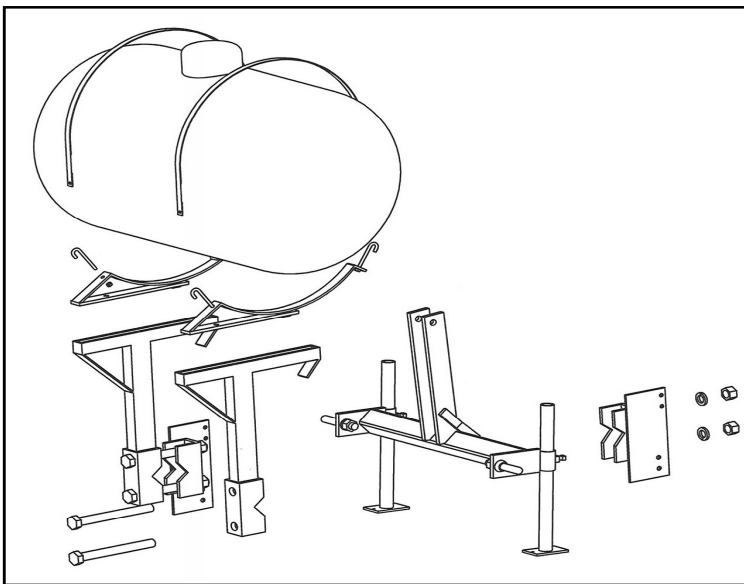

3-Point Hitch & Barrel Mounting

1. On the 3-point hitch, connect the Category I hitch pins through the holes on the outside of the hitch. Put the pins in through the outside and secure with the lock washer and hex nut included with the pin.
2. Slide the green pipe stands up through the pipes on the hitch, then tighten by turning the set screw.

Note: The following instructions will be easier with two people



3. Center the 3-point hitch toolbar with the clamps on your transplanter. Next, line up one of the barrel mounting brackets with the direct drive clamps. Secure using two 1 x 8-1/2 bolts and hex nuts. Do the same with the other barrel mounting bracket.



Side view of B-3 mountings



4. Bolt barrel hoops onto B-3 supports using 1/2 x 3" hex bolt with 1/2" lock nut. Note below: the hoops can be mounted in a forward or back position, depending on clearance that you need for the tractor fenders etc.



5. Screw in the nipple into the bottom of the tank.



6. Insert J-bolts into the four holes on the barrel hoops. It works best to thread 5/16" nut onto J-bolt before hooking up barrel hoops.



7. The 55 gallon poly tank can now be mounted on top of the barrel mountings. Use the four J-bolts and the galvanized straps to secure the barrel to the mountings.

A. Grease all fittings before the start of each day. Grease fittings are found:

1. On each packing wheel axle.
2. Upper pocket chain sprocket (Model 1000 only)
3. Direct drive tire hub (Direct Drive Units only)
4. On each nylon bushing on the pocket chain jackshaft.

B. Regulating Plant Depth

1. All operators should take care to see that the plants are placed well down in the pocket so the plant is held firmly.
2. The plant depth is regulated by the distance the root is extended out of the pocket.
3. To set the plants deeper, simply set the plant in the pocket with the roots further out than what is normally done. (See figure below)
4. If planting strawberries the axle must be raised up, allowing the transplanter unit to go deeper into the soil to cover the strawberry crowns.



V-3 Standard Plant Placement



Deeper Plant Placement

C. Pocket Chain Instructions

1. Make sure that bolts holding the upper sprocket on the pocket chain are not too tight. This will cause unnecessary friction on the unit and possible slippage on packing wheel drive transplanter. Simply loosen the wing nuts if the chain seems too tight.
2. Tighten the wing nuts equally by the top sprocket to keep the chain running level at all times.
3. If in row spacings of 20" or greater are needed, use only 6 pockets. You may remove every other pocket or leave them on. This gives the same speed or greater as a 12 pocket chain.

D. Adjusting or setting the #395R Round Point Shoe

Note: The shoe is preset at the factory for almost all situations.

Follow these instructions only if plants are leaning or in extreme wet or dry soil conditions.

1. Whenever any adjustments are made, be sure to get the shoe directly square and straight in front of the opening of the packing wheels. Make sure that the pockets will run through the middle of the shoe.
2. In loose dry soil, the shoe should be adjusted closer to the packing wheels. This can be done by adjusting the diagonal brace on the shoe.
3. In wet heavy soil, the shoe should be adjusted away from the packing wheels. Again, this can be done by adjusting the diagonal shoe brace.
4. Keep the shoe clean at all times. Do not allow dirt or trash to build up on the front or side of the shoe because this can cause too wide of a furrow that cannot be closed properly by the packing wheels. Poly covered shoes will eliminate this problem.

E. Water Valve Adjustment

1. For more water, make sure the valve is getting a full stroke by adjusting the #604 bracket on the pump rod. Make sure the valve does not over stroke. You should be able to lift the 604 rod 1/4-1/2" at the top of its stroke.
2. A broad range of adjustment can be achieved with the #603 water cam.
3. For wider spacings, the water cam may have to be raised so the water is on the plant. If the #603 is raised, be sure to raise the #604 water adjustment bracket accordingly and do not over stroke.

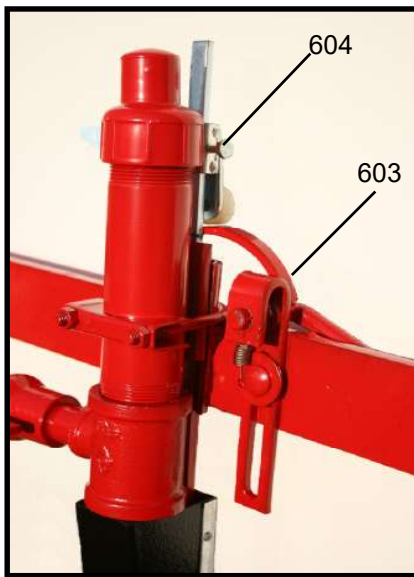

Example: At 20" row spacing, the #603 water cam should be adjusted nearly all the way up the slot. The #604 water adjustment must also be adjusted accordingly so a 1/2" remains on the 604 stroke.

4. Tilting the #603 water cam back towards the water trips on the pockets will create a longer stroke of water or more water before and after the plant.
5. Always empty the water out of the valve after quitting for the day. **Water freezing inside the valve will destroy the #610 and #612 balls inside the valve.**

F. Direct Drive Float Wheel Operation

1. Use only 4 to 5 pounds of air pressure in the Direct Drive Wheel during operation.



Wrong
Toolbar too high



Correct



Wrong
Toolbar too low

2. It is very important when starting to transplant, that the lift chains on the side of the Direct Drive Wheel are loose. See above "Correct" picture.
3. When lowering the transplanting unit into the ground, be sure that the frame members on the Direct Drive Wheel run parallel as is shown in the center picture. This is adjusted by the height of the hitch or toolbar (a pair of gauge wheels will eliminate adjustment of toolbar height).
4. Running the frame parallel will keep the lift chains loose allowing for proper floatation in the Direct Drive Wheel.
5. Running the frame members parallel and level will allow the packing wheels to run in the proper packing position.
6. Running the toolbar too low will tighten the back chains and cause the packing wheels to run too light and not pack the soil properly.
7. Running the toolbar too high will tighten the front lift chains and cause the Direct Drive Wheel to not run on the ground, especially through low spots.

Trouble Shooting

Important - Before attempting any of the following, make sure that the unit is running level or parallel to the ground. Do not run the front hitch or toolbar too far down or up. On all Model 1000 series units, make sure that the chains are loose on both sides of the arch bracket over the drive wheel. For all transplanter, make sure the soil is worked deep enough.

Problem

Solution

Packing wheels not packing properly

- A. Lengthen third arm on tractor to get float in hitch
- B. Hitch is too far down and needs to be lifted (lift chains are not loose)
- C. Clean off sides of shoe
- D. Work soil deeper
- E. Add weight to back of unit
- F. Poly shoes will eliminate soil building up on the outsides

Water leaks from top of water valve

- A. Check to see if the rubber nipple inside the top of the valve is in place and rounded.
- B. #610 ball inside the valve has collapsed and needs to be replaced.

Water leaks from bottom of water valve

- A. Rubber ball #612 on pin is broke and needs to be replaced
- B. The nylon nut on the bottom is broken and needs to be replaced

Water not uniform

- A. Make sure all the water trips on the pockets are in good shape and at even distances from the attachment link.
- B. Check to see that all springs on the water valve are in good working order.
- C. Water valve has dirt or residue build up that needs to be cleaned out

Water misses plants

•See water valve instructions on Page13.

Plants falling out of pocket

- A. Inspect the rubber grippers to make sure that they are not all stretched out.
- B. Tighten the L-bolts on the side of the guides.
- C. #482 pocket extensions may be needed if planting cell-type plants.
- D. Check bottom of guides to insure that the pocket is not releasing the plant too soon.

Plants on top of soil

- A. Cut back on water because the plants are floating up out of the shoe.
- B. Plants need to be pulled further out of the pocket to put them deeper.
- C. Too much loose soil is getting inside the shoe before the packing wheels can pack. Move shoe closer to packing wheels.
- D. A gap might be occurring by having the hitch too low causing the packing wheels to be up in the air or not being able to put enough pressure on the soil.
- E. Ground not worked deep enough causing the shoe to not go deep enough into the soil.

Plants leaning

- A. Need to put plant further in the pocket to keep it from hitting the bottom of the furrow.
- B. Possibility of needing a deeper shoe.
- C. May need #482 extensions to help support the cell of a plant coming from a tray.
- D. See Operating Instructions on Page 13 about adjusting the shoe.

Safety Precautions

1. Make sure tractor is stopped and in neutral with the transplanter lowered to the ground before getting on and off the unit.
2. No operator is allowed to be on the unit as it is raised and lowered.
3. No operator is allowed on the transplanter as it is transported to or from the field.
4. All operators must be seated before movement begins and remain seated until the transplanter is completely stopped.
5. Never leave the transplanter in the raised position.
6. Keep all shields and guards in place when operating the transplanter.
7. Never attempt repairs or maintenance while the transplanter is in motion.
8. Never put the tractor in reverse while the transplanter is on the ground.
9. Follow all safety instructions supplied by the tractor manufacturer to which the transplanter is mounted.

MACHINE IMPROVEMENTS

MECHANICAL TRANSPLANTER CO. IS ALWAYS STRIVING TO MAKE IMPROVEMENTS ON THEIR LINE OF EQUIPMENT. MECHANICAL TRANSPLANTER CO. RESERVES THE RIGHT TO MAKE IMPROVEMENTS AND CHANGES AT ANY TIME WITHOUT INCURRING OBLIGATIONS TO MAKE SUCH CHANGES OR ADDITIONS TO EQUIPMENT PREVIOUSLY SOLD.

Limited Warranty

Mechanical Transplanter Company warrants each item of new equipment manufactured by Mechanical to be free from defects in material and workmanship under normal use and service.

The obligation of Mechanical Transplanter Company under this LIMITED WARRANTY is limited to repairing or replacing as Mechanical may elect, and any parts that prove, in Mechanical's judgment, to be defective in material and workmanship within the first season's use or 45 consecutive days after initially placing equipment in operation, whichever occurs first. Any outside work or alterations without Mechanical's written approval will render the LIMITED WARRANTY void.

Mechanical's obligation specifically excludes any liability for consequential damages, such as loss of profits, delays, expenses, damage to goods or property used in connection with or processed in or by the product sold, or damage to the product sold from whatsoever cause, whether or not such loss is due to negligence of selling dealer of Mechanical Transplanter Company.

This limited warranty shall not apply to any item or machine which shall have been operated in a manner not recommended by the Company nor which shall have been repaired, altered, misused, damaged in an accident, neglected, tampered with or used in any way which in the Company's opinion adversely affects its performance and results.

No person is authorized to give any other warranties or to assume any other liability on behalf of Mechanical Transplanter Company, unless made in writing by Mechanical.

This limited warranty covers repair or replacement of Mechanical Transplanter Co. equipment only and does not cover crop loss, downtime, labor, damage to other equipment, etc.

This limited warranty does not apply to exterior finishes, tires, chain links, bearings, or any other items sold by Mechanical Transplanter Co., but warranted by the original manufacturer except to the extent of their individual manufacturer's warranty.

THIS LIMITED WARRANTY IS IN LIEU OF ALL OTHER WARRANTIES, EXPRESSED OR IMPLIED. WARRANTIES OF MERCHANTABILITY AND FITNESS FOR PARTICULAR PURPOSE ARE EXCLUDED, AS ARE ALL OTHER REPRESENTATIONS TO THE USER-PURCHASER, AND ALL OTHER OBLIGATIONS OR LIABILITIES, INCLUDING LIABILITY FOR INCIDENTAL AND CONSEQUENTIAL DAMAGES, ON THE PART OF MECHANICAL OR THE SELLER.

Mechanical Transplanter Co.

Model 1000 and 1000B-3

Operators Manual



Mechanical Transplanter Co., LLC
1150 Central Avenue • Holland, MI 49423-5230
Phone: 616-396-8738 • Fax: 616-396-3619
website: www.mechanicaltransplanter.com
e-mail: mtc@mechanicaltransplanter.com

Spacing Charts and Information

| SPACING CHART FOR DIRECT DRIVE UNIT W/ 12 POCKET CHAIN | | | | | | |
|---|---------------------------------|-------------------------------------|-----------------------|-----------------------|-------------------|-----------------|
| Sprocket on OUT-SIDE of Jackshaft | Sprocket on INSIDE of Jackshaft | Number of Teeth on Sprocket on Unit | | | | |
| | | 7 | 8 | 9 | 10 | 11 |
| 7 | 11 | 6" 15.2cm | 6-1/2" - 7" 17.8cm | 7-1/2" - 8" 20.3cm | 8-1/2" 21.6cm | 9" 22.8cm |
| 7 | 7 | 9" 22.8cm | 10-1/2" 26.7cm | 13" 33cm | 15" 38.1cm | 16" 40.6cm |
| 8 | 7 | 10-1/2" 26.7cm | 12-1/2" 31.7cm | 14" 35.5cm | 15" 38.1cm | 16" 40.6cm |
| 9 | 7 | 12" 30.5cm | 13-1/2" 34.3cm | 15" 38.1cm | 17" 43.2cm | 18-1/2" 47cm |
| 10 | 7 | 13" 33cm | 14" 35.5cm | 15-1/2" 39.4cm | 17-1/2" 44.5cm | 20-1/2" 52cm |
| 11 | 7 | 15" 38.1cm | 18" 45.7cm | | | |

Double any of the above spacings by using every other pocket (6 pocket).
Make sure HITCH and UNIT are level or parallel to the ground when planting.

Use for Model 1000

| DISC SPACING CHART FOR MODELS W/ DIRECT DRIVE | | | | | | | |
|--|---------------------------------|-------------------------------|-------------------------------------|--------|--------|--------|--------|
| Sprocket on OUTSIDE of Jackshaft | Sprocket on INSIDE of Jackshaft | Number of Pockets on the Disc | Number of Teeth on Sprocket by Disc | | | | |
| | | | 7 | 8 | 9 | 10 | 11 |
| 7 | 7 | 24 | | 2" | 2-1/4" | 2-1/2" | 2-3/4" |
| | | 16 | 3" | 3-1/4" | 3-1/2" | 4" | 4-1/2" |
| | | 12 | | 4-3/4" | 5-1/4" | 5-3/4" | 6-1/4" |
| 8 | 7 | 24 | | 2-1/2" | 3" | 3-1/4" | 3-1/2" |
| | | 16 | 3-1/2" | 3-3/4" | 4-1/4" | 4-1/2" | 5-1/4" |
| | | 12 | | 6" | 6-1/4" | 6-3/4" | 7" |
| 9 | 7 | 24 | 2-1/2" | 2-3/4" | 3-1/4" | 3-1/2" | 4" |
| | | 16 | 3-3/4" | 4-1/4" | 4-1/2" | 5" | 5-1/2" |
| | | 12 | 4-1/2" | 6-1/4" | 6-1/2" | 7-1/4" | 8" |
| 10 | 7 | 24 | 2-1/2" | 3" | 3-1/2" | 3-3/4" | 4-1/2" |
| | | 16 | 3-3/4" | 4-1/2" | 5-1/4" | | |
| | | 12 | 5-1/4" | 6" | 7" | 7-1/2" | 8-1/2" |
| 11 | 7 | 24 | 2-1/2" | 3" | 3-1/2" | 4-1/4" | 4-3/4" |
| | | 16 | 4" | 5" | 6" | | |
| | | 12 | 5-1/2" | 6-1/2" | 7-1/2" | 9" | 10" |

Use for Model 1000 with disc mounted pockets

Assembly Instructions

For Model 1000 Series Transplanters

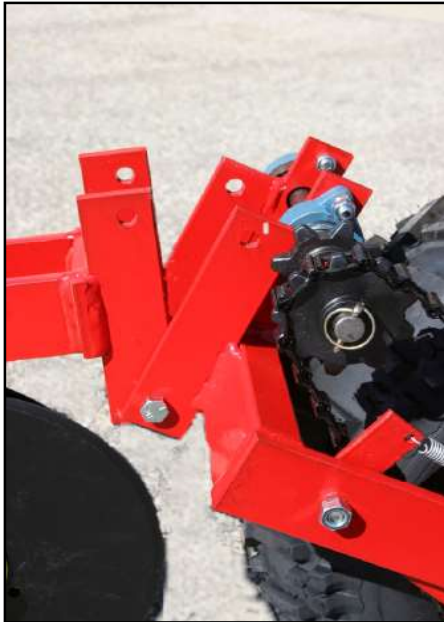

1. Bolt on the Direct Drive Float Wheel using the four 1/2 x 1-1/2 " bolts. Secure using the 1/2" hex nuts.



2. Remove the following parts from the direct drive wheel jackshaft: Clip pin, drive chain coming from the wheel, outside sprocket on jackshaft, and pipe spacer. Then remove the extra top hex nut located on the flange bearing.



3. Install the inside chain guard of the unit. Fasten front short tab to the top bolt on flange bearing from #2 photo with hex nut. The long tab attaches to the empty hole on the transplanter frame by the packing wheels. The guard must fit between the shoe brace and the guide adjustment bolt. Use the 3/8 x 1" bolt and a 3/8" hex nut to secure.

4. Select the proper sprocket arrangement for the spacing needed between plants. Look on page 2 or the chart on the side of your transplanter for the correct arrangement. For spacings using 11 tooth sprockets, extra chain links may be needed to lengthen the drive chain. These links are wired to the lift chain by the drive wheel. After finding the correct sprockets, run the long drive chain from the sprocket on the pocket chain shaft to the inside sprocket on the jackshaft of the direct drive wheel. The chain must go over the idler sprocket on the shoe brace and under the chain tightener sprocket as shown in the photo below.



5. Slide the red pipe spacer back onto the jackshaft. Insert the roll pin back into the second hole from the outside of the jackshaft. Slide the outside sprocket over the roll pin. Slide the drive chain coming from the drive wheel over the outside jackshaft sprocket. You may have to use your hand to push the chain tightener up to create enough slack in the chain. Insert the clip pin into the outside hole of the jackshaft.



6. Slide the outside chain guard onto the two pins and secure with clip pins.

Installation of Plant Stands

It is very important to know what row width will be used before installing the plant stands on multi-row transplanter. Follow the chart below.

- 42" Row Spacing - All Wide Plant Boxes
- 41" to 36" Row Spacing - Narrow Plant Boxes Inside
- 35" to 24" Row Spacing - One Wide Inside & Two Wide Outside
- 23" to 21" Row Spacing - One Narrow Inside & Two Wide Outside
- Less than 21" Row Spacing - Wide Outside Plant Boxes Only



1. Remove the long bolt between the uprights by the pocket chain. Do not lose the spacer between the uprights. Remove the outside cotter key in each axle.



2. Install the slotted mounting plates on both sides of the planter using the long bolt just removed. Do not tighten until the plant stand is fully assembled.



3. Slide plant stand onto the packing wheel axle and insert cotter key. Bend cotter key ends to keep in place.

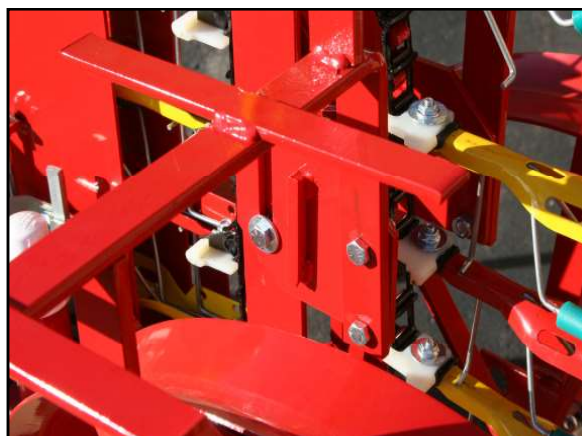

4. Use two 3/8 x 1" hex head bolts and two 3/8" nuts to attach plant stand frame to the slotted mounting bracket.



5. Attach the width adjustment plate with either the inside or outside hole depending on if you are using the wide (standard) plant boxes or the narrow with 3/8 x 1" hex head bolt and nut.

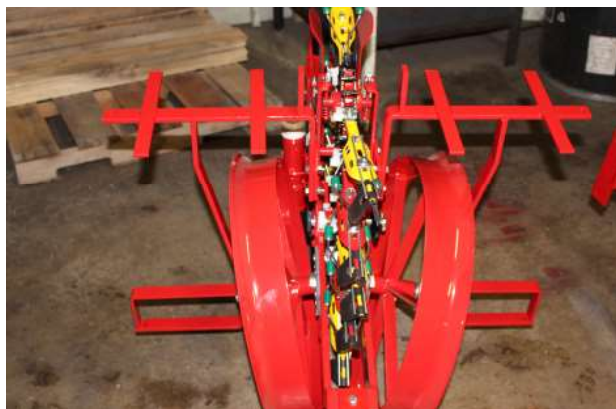

6. Install the plant boxes. These can be adjusted forward or backward for operator comfort.



Assembling the L-Shaped Seat Braces



1. Assemble the L-shaped seat brace by the chain guard. The sea brace mounts on the inside of the frame. The U-bolt mounts from the outside of the transplanter frame under the chain guard. Secure with 1/2" washers and 1/2" hex nuts over each threaded end.



2. The second L-shaped seat brace gets attached on the outside of the transplanter opposite the chain guard. The seat brace mounts on the outside of the frame with the U-bolt coming from the inside of the frame going outside through the seat brace. Secure with 1/2" washers and 1/2" hex nuts over each threaded end.

Mounting your Fiberglass or Cushion Seat

•Fiberglass Seats•



Fiberglass Seat - Turn your fiberglass seat over and remove any covers over the threaded studs. Take your green fiberglass seat bracket and mount it to the bottom of the seat with the side with the bend towards the front of the seat. Secure with four 1/4" hex nuts. Insert the 1/2 x 1-1/2 carriage bolt through the brace and then through the L-shaped seat bracket. Secure with a 1/2" washer and hex nut.

•Cushion Seats•

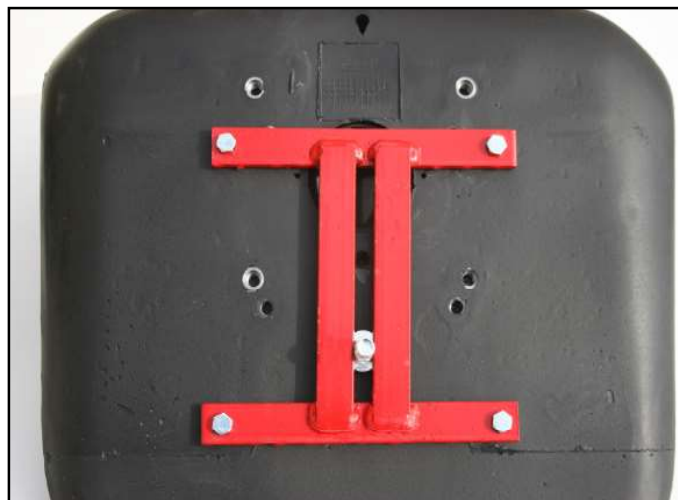

Cushion Seat - Slide the 1/2" x 1-1/2" carriage bolt through the bottom of the red seat bracket before mounting the seat bracket to the seat. After placing the carriage bolt through the seat bracket, place the seat on the L-shaped seat bracket and secure with a 1/2" washer and hex nut.

Loose Pocket Assembly

If your Model 1000 was shipped in a crate, a pocket must be put on the empty attachment link.

The empty attachment link should be right at the top of the chain when the unit is shipped. If it is not, turn the drive wheel until the empty attachment link comes to the top.



Do NOT put #445 rubber gripper onto spring wires(#440) until pocket is assembled to attachment link.

Take the extra V-3 pocket that is wired onto unit and loosen the pocket bolt. Put pocket bolt through the attachment link. Make sure spacing bar stays under the head of the bolt. Place #375 water trip on the back of attachment link, then the 1/4" fender washer. Secure with 1/4" flange nut. After the bolt has been tightened, slide the top part of the #445 rubber gripper to the #440 wire.

Instructions for Direct Drive Clamps

The following instructions are for mounting the direct drive clamps to your Model 1000 unit. Although the pictures show the 2-1/2" clamps, use these instructions for any clamp style. They all mount the same way.



1. Insert a metal bushing from the inside of the frame. Put one of the 1/2 x 1-1/2" bolts through the bushing also from the inside.



2. Attach the clamp to the bolt in the **top** hole of the bottom set of large holes. Secure with a 1/2" hex nut.
3. If you have a Model 1000B-3 or 1000-2 follow directions below for one clamp side only. To mount safety bar on other clamp side, see page 11. In the **top** set of holes, place a 7/16 x 1-1/4" bolt through the top hole.

4. Slide the end link of the chain onto the bolt.
5. Secure the chain with a 3/8" washer and then a 7/16" hex nut. Make sure the nut is very tight.





6. Use the same instructions for the other side of the Direct Drive Wheel.

Note: The clamps may be reversed or fastened on the inside of the frame for narrow row spacings. Also, if other clamps are in the way, two lefts or two rights may be used. The lower holes on the clamps are for higher toolbars on older models or on tractors where 3-point hitch will not go low enough. Correct height of toolbar is 14" to center.

The Model 1000 unit can now be mounted to your 3-point hitch or toolbar. Following is a list of fasteners that you must use for various toolbars.

Toolbar Hardware List

- 2-1/2" or 2-1/4" Diamond toolbar - 7/8" V-bend U-bolt (2)
- 3" x 3" Flat Toolbar - 3/4" x 5" Hex bolts (4)
- 4" x 4" Flat Toolbar - 3/4" x 6" Hex bolts (4)
- 4" x 7" Toolbar - 3/4" x 9-1/2" Hex bolts (4)
- 5" x 7" Toolbar - 3/4" x 7" Hex bolts (4)
- 7" x 7" Toolbar - 3/4" x 9-1/2" (4)



Shown with clamps reversed

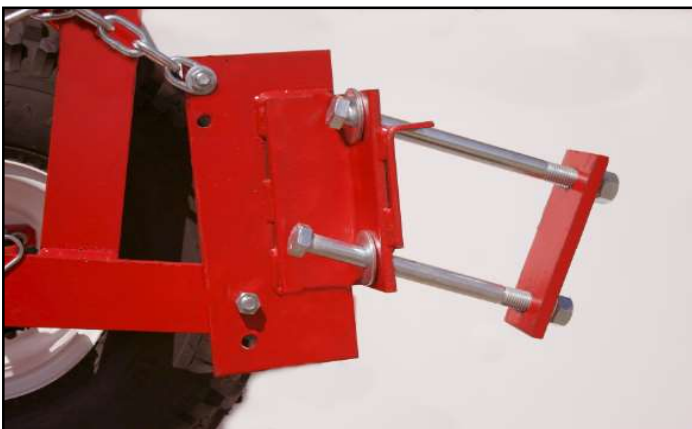

4 x 7 Toolbar Clamp. Use 2-3/4 x 9-1/2" hex bolts, 2-3/4" hex nuts and 2-3/4" washers.

Note: bent bracket on front of clamp

Model 1000B-3 Barrel Mounting & 3-Point Hitch Instructions



For B-3 Model, make sure the safety bar is properly installed!

To mount this safety bar, you must remove the 7/16 x 1-1/4" bolt from on side of the direct drive wheel.

1. Locate the special 2-1/2" stud in your bag of bolts and nuts.
2. Turn a 7/16" hex nut all the way onto the stud.
3. Put the 7/16" washer on the stud next to the nut.
4. Place the lift chain up against the washer.
5. Slide the stud through the hole on the Direct Drive frame and secure with a 7/16" hex nut.
6. Assemble another stud the same way and fasten it to the top hole of the front Direct Drive clamp.
7. Attach the red seat safety bar to the stud on your drive wheel. **The end with the hole must go on the clamp. The slotted end must go on the frame.** After the safety bar is attached, place the small clip pins through the small holes.

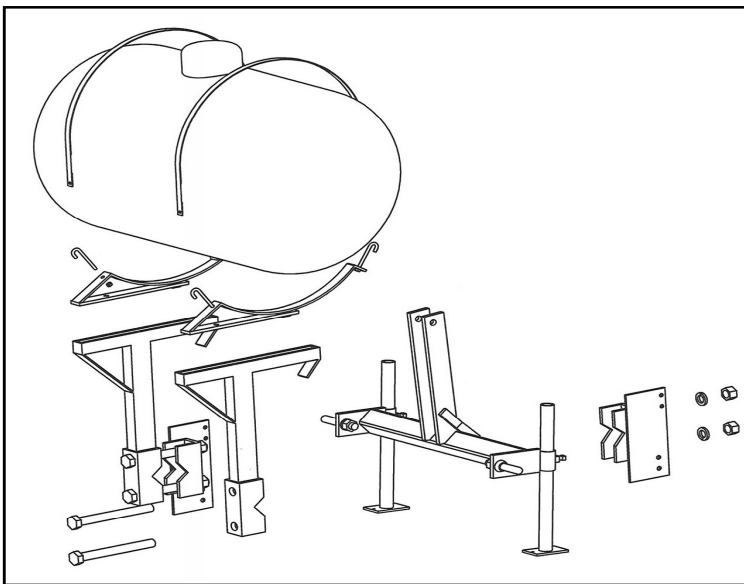

3-Point Hitch & Barrel Mounting

1. On the 3-point hitch, connect the Category I hitch pins through the holes on the outside of the hitch. Put the pins in through the outside and secure with the lock washer and hex nut included with the pin.
2. Slide the green pipe stands up through the pipes on the hitch, then tighten by turning the set screw.

Note: The following instructions will be easier with two people



3. Center the 3-point hitch toolbar with the clamps on your transplanter. Next, line up one of the barrel mounting brackets with the direct drive clamps. Secure using two 1 x 8-1/2 bolts and hex nuts. Do the same with the other barrel mounting bracket.



Side view of B-3 mountings



4. Bolt barrel hoops onto B-3 supports using 1/2 x 3" hex bolt with 1/2" lock nut. Note below: the hoops can be mounted in a forward or back position, depending on clearance that you need for the tractor fenders etc.



5. Screw in the nipple into the bottom of the tank.



6. Insert J-bolts into the four holes on the barrel hoops. It works best to thread 5/16" nut onto J-bolt before hooking up barrel hoops.



7. The 55 gallon poly tank can now be mounted on top of the barrel mountings. Use the four J-bolts and the galvanized straps to secure the barrel to the mountings.

A. Grease all fittings before the start of each day. Grease fittings are found:

1. On each packing wheel axle.
2. Upper pocket chain sprocket (Model 1000 only)
3. Direct drive tire hub (Direct Drive Units only)
4. On each nylon bushing on the pocket chain jackshaft.

B. Regulating Plant Depth

1. All operators should take care to see that the plants are placed well down in the pocket so the plant is held firmly.
2. The plant depth is regulated by the distance the root is extended out of the pocket.
3. To set the plants deeper, simply set the plant in the pocket with the roots further out than what is normally done. (See figure below)
4. If planting strawberries the axle must be raised up, allowing the transplanter unit to go deeper into the soil to cover the strawberry crowns.



V-3 Standard Plant Placement



Deeper Plant Placement

C. Pocket Chain Instructions

1. Make sure that bolts holding the upper sprocket on the pocket chain are not too tight. This will cause unnecessary friction on the unit and possible slippage on packing wheel drive transplanter. Simply loosen the wing nuts if the chain seems too tight.
2. Tighten the wing nuts equally by the top sprocket to keep the chain running level at all times.
3. If in row spacings of 20" or greater are needed, use only 6 pockets. You may remove every other pocket or leave them on. This gives the same speed or greater as a 12 pocket chain.

D. Adjusting or setting the #395R Round Point Shoe

Note: The shoe is preset at the factory for almost all situations.

Follow these instructions only if plants are leaning or in extreme wet or dry soil conditions.

1. Whenever any adjustments are made, be sure to get the shoe directly square and straight in front of the opening of the packing wheels. Make sure that the pockets will run through the middle of the shoe.
2. In loose dry soil, the shoe should be adjusted closer to the packing wheels. This can be done by adjusting the diagonal brace on the shoe.
3. In wet heavy soil, the shoe should be adjusted away from the packing wheels. Again, this can be done by adjusting the diagonal shoe brace.
4. Keep the shoe clean at all times. Do not allow dirt or trash to build up on the front or side of the shoe because this can cause too wide of a furrow that cannot be closed properly by the packing wheels. Poly covered shoes will eliminate this problem.

E. Water Valve Adjustment

1. For more water, make sure the valve is getting a full stroke by adjusting the #604 bracket on the pump rod. Make sure the valve does not over stroke. You should be able to lift the 604 rod 1/4-1/2" at the top of its stroke.
2. A broad range of adjustment can be achieved with the #603 water cam.
3. For wider spacings, the water cam may have to be raised so the water is on the plant. If the #603 is raised, be sure to raise the #604 water adjustment bracket accordingly and do not over stroke.

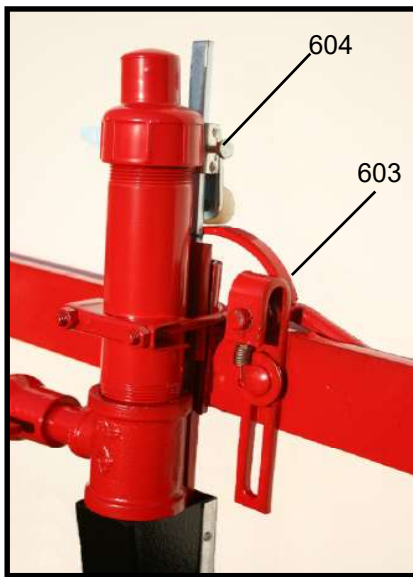

Example: At 20" row spacing, the #603 water cam should be adjusted nearly all the way up the slot. The #604 water adjustment must also be adjusted accordingly so a 1/2" remains on the 604 stroke.

4. Tilting the #603 water cam back towards the water trips on the pockets will create a longer stroke of water or more water before and after the plant.
5. Always empty the water out of the valve after quitting for the day. **Water freezing inside the valve will destroy the #610 and #612 balls inside the valve.**

F. Direct Drive Float Wheel Operation

1. Use only 4 to 5 pounds of air pressure in the Direct Drive Wheel during operation.



Wrong
Toolbar too high



Correct



Wrong
Toolbar too low

2. It is very important when starting to transplant, that the lift chains on the side of the Direct Drive Wheel are loose. See above "Correct" picture.
3. When lowering the transplanting unit into the ground, be sure that the frame members on the Direct Drive Wheel run parallel as is shown in the center picture. This is adjusted by the height of the hitch or toolbar (a pair of gauge wheels will eliminate adjustment of toolbar height).
4. Running the frame parallel will keep the lift chains loose allowing for proper floatation in the Direct Drive Wheel.
5. Running the frame members parallel and level will allow the packing wheels to run in the proper packing position.
6. Running the toolbar too low will tighten the back chains and cause the packing wheels to run too light and not pack the soil properly.
7. Running the toolbar too high will tighten the front lift chains and cause the Direct Drive Wheel to not run on the ground, especially through low spots.

Trouble Shooting

Important - Before attempting any of the following, make sure that the unit is running level or parallel to the ground. Do not run the front hitch or toolbar too far down or up. On all Model 1000 series units, make sure that the chains are loose on both sides of the arch bracket over the drive wheel. For all transplanter, make sure the soil is worked deep enough.

Problem

Solution

Packing wheels not packing properly

- A. Lengthen third arm on tractor to get float in hitch
- B. Hitch is too far down and needs to be lifted (lift chains are not loose)
- C. Clean off sides of shoe
- D. Work soil deeper
- E. Add weight to back of unit
- F. Poly shoes will eliminate soil building up on the outsides

Water leaks from top of water valve

- A. Check to see if the rubber nipple inside the top of the valve is in place and rounded.
- B. #610 ball inside the valve has collapsed and needs to be replaced.

Water leaks from bottom of water valve

- A. Rubber ball #612 on pin is broke and needs to be replaced
- B. The nylon nut on the bottom is broken and needs to be replaced

Water not uniform

- A. Make sure all the water trips on the pockets are in good shape and at even distances from the attachment link.
- B. Check to see that all springs on the water valve are in good working order.
- C. Water valve has dirt or residue build up that needs to be cleaned out

Water misses plants

•See water valve instructions on Page13.

Plants falling out of pocket

- A. Inspect the rubber grippers to make sure that they are not all stretched out.
- B. Tighten the L-bolts on the side of the guides.
- C. #482 pocket extensions may be needed if planting cell-type plants.
- D. Check bottom of guides to insure that the pocket is not releasing the plant too soon.

Plants on top of soil

- A. Cut back on water because the plants are floating up out of the shoe.
- B. Plants need to be pulled further out of the pocket to put them deeper.
- C. Too much loose soil is getting inside the shoe before the packing wheels can pack. Move shoe closer to packing wheels.
- D. A gap might be occurring by having the hitch too low causing the packing wheels to be up in the air or not being able to put enough pressure on the soil.
- E. Ground not worked deep enough causing the shoe to not go deep enough into the soil.

Plants leaning

- A. Need to put plant further in the pocket to keep it from hitting the bottom of the furrow.
- B. Possibility of needing a deeper shoe.
- C. May need #482 extensions to help support the cell of a plant coming from a tray.
- D. See Operating Instructions on Page 13 about adjusting the shoe.

Safety Precautions

1. Make sure tractor is stopped and in neutral with the transplanter lowered to the ground before getting on and off the unit.
2. No operator is allowed to be on the unit as it is raised and lowered.
3. No operator is allowed on the transplanter as it is transported to or from the field.
4. All operators must be seated before movement begins and remain seated until the transplanter is completely stopped.
5. Never leave the transplanter in the raised position.
6. Keep all shields and guards in place when operating the transplanter.
7. Never attempt repairs or maintenance while the transplanter is in motion.
8. Never put the tractor in reverse while the transplanter is on the ground.
9. Follow all safety instructions supplied by the tractor manufacturer to which the transplanter is mounted.

MACHINE IMPROVEMENTS

MECHANICAL TRANSPLANTER CO. IS ALWAYS STRIVING TO MAKE IMPROVEMENTS ON THEIR LINE OF EQUIPMENT. MECHANICAL TRANSPLANTER CO. RESERVES THE RIGHT TO MAKE IMPROVEMENTS AND CHANGES AT ANY TIME WITHOUT INCURRING OBLIGATIONS TO MAKE SUCH CHANGES OR ADDITIONS TO EQUIPMENT PREVIOUSLY SOLD.

Limited Warranty

Mechanical Transplanter Company warrants each item of new equipment manufactured by Mechanical to be free from defects in material and workmanship under normal use and service.

The obligation of Mechanical Transplanter Company under this LIMITED WARRANTY is limited to repairing or replacing as Mechanical may elect, and any parts that prove, in Mechanical's judgment, to be defective in material and workmanship within the first season's use or 45 consecutive days after initially placing equipment in operation, whichever occurs first. Any outside work or alterations without Mechanical's written approval will render the LIMITED WARRANTY void.

Mechanical's obligation specifically excludes any liability for consequential damages, such as loss of profits, delays, expenses, damage to goods or property used in connection with or processed in or by the product sold, or damage to the product sold from whatsoever cause, whether or not such loss is due to negligence of selling dealer of Mechanical Transplanter Company.

This limited warranty shall not apply to any item or machine which shall have been operated in a manner not recommended by the Company nor which shall have been repaired, altered, misused, damaged in an accident, neglected, tampered with or used in any way which in the Company's opinion adversely affects its performance and results.

No person is authorized to give any other warranties or to assume any other liability on behalf of Mechanical Transplanter Company, unless made in writing by Mechanical.

This limited warranty covers repair or replacement of Mechanical Transplanter Co. equipment only and does not cover crop loss, downtime, labor, damage to other equipment, etc.

This limited warranty does not apply to exterior finishes, tires, chain links, bearings, or any other items sold by Mechanical Transplanter Co., but warranted by the original manufacturer except to the extent of their individual manufacturer's warranty.

THIS LIMITED WARRANTY IS IN LIEU OF ALL OTHER WARRANTIES, EXPRESSED OR IMPLIED. WARRANTIES OF MERCHANTABILITY AND FITNESS FOR PARTICULAR PURPOSE ARE EXCLUDED, AS ARE ALL OTHER REPRESENTATIONS TO THE USER-PURCHASER, AND ALL OTHER OBLIGATIONS OR LIABILITIES, INCLUDING LIABILITY FOR INCIDENTAL AND CONSEQUENTIAL DAMAGES, ON THE PART OF MECHANICAL OR THE SELLER.