



TATO

DREAMED AND MADE IN ITALY



DREAMED AND MADE IN ITALY

Tato nasce con l'intenzione di fare bene le cose. È questo il suo campo di attività. Esiste un sapere profondo che si costruisce nella pratica del fare. Fare bene le cose per un'azienda che produce apparecchi d'illuminazione e tutto ciò che si configura come oggetto di arredamento significa esprimere un modo di essere e una precisa disposizione: progettare, con studiattissimo understatement, una propria idea di libertà, un'idea di nuovo che non si cerca perché è quotidianamente vissuto.

Quella di Tato è un'idea di design che traduce in un nuovo scenario economico e culturale e declina al futuro la lunga tradizione di abilità manuale, di conoscenza dei gesti e dei materiali, di perizia e destrezza del lavoro artigiano che costituisce da sempre un elemento di riconoscibilità dell'Italia nel mondo. Non c'è industria di qualità che possa fare a meno dell'artigianato.

Il continuo lavoro manuale sul materiale e sulle forme che esso può assumere, la sorpresa e l'intima e nuova familiarità che ne deriva, ci restituisce degli oggetti che sono, in qualche modo, personaggi e presenze, che conversano dentro a un'architettura, si sentono sempre a loro agio e sanno comportarsi.

Cose capaci di mantenere nel tempo il loro valore. Il buon design inizia sempre dalle persone.

Tato si circonda di quelle che un poco gli assomigliano ma soprattutto di quelle che sono molto diverse. Non solo di architetti e designer ma di un circuito intellettuale vasto e caratterizzato da un'attitudine alla ricerca e alla sperimentazione. Sono soprattutto importanti le relazioni legate ai saperi artigianali del territorio in cui l'azienda è nata e quelle internazionali che contribuiscono a diffondere il suo pensiero. Cruciale è poi ascoltare le persone, sempre più numerose e sempre più sofisticate, che cercano storia e cultura nelle cose che scelgono.

Per Tato la cultura è importante e s'impegna in diverse operazioni. Gli piace ripescare nella storia perché esistono degli oggetti che sembrano fatti oggi benché appartengano al nostro ieri o forse all'altrove.

Tato was conceived to do things well. This is what it's dealing with. There's a deep knowledge arising from the practice. Doing things well for a company producing lighting design and furnishing items, means to express a way to be and a precise attitude. It means to purposely design in an understated way a personal idea of what freedom is, a personal idea of new, of something you don't look for, because you live with it every day.

Tato's design concept results in a new economic and cultural scenario and in a future-oriented tradition of manual dexterity, knowledge of gestures and materials, handicrafts. All those elements that make Italy wellknown in the world. There is no industry that can do without handicrafts.

The constant manual working the material and the forms it can take, the surprise and the intimate familiarity deriving from it, gives us back a number of objects representing characters, talking to us within an architecture, feeling always comfortable and behaving. These objects can keep their value over time.

A good design begins with people. Tato surrounds himself with people who are similar but also with very different ones. Not only architects and designers but a large intellectual group aiming to research and experiment. Particularly significant are those relationship with the local handicrafts in the area where the company was born and the international relationship, helping to spread its ideas. Listening to people is crucial. More and more people, sophisticated people, looking for history and culture in the things they choose.

Tato takes culture into particular account and is engaged in many processes. Tato likes to dig out from history those objects that are produced today but belong to our recent past or just to our past.

NON SI TRATTA SOLO DI BUON DESIGN

C'è una qualità speciale in certe imprese di design, quella di considerare l'istanza estetica come sua base fondativa, anche dal punto di vista economico. Perché sono sempre più i contenuti culturali a indicare le scelte delle persone.

TATO propone un nuovo modello strutturato e poetico in cui la ricerca visiva si combina alla sperimentazione industriale, la filologia su materiali e tecniche, nuove e antiche, alla scoperta di nuove geografie produttive per costruire un catalogo che privilegia gli stimoli contenutistici ai vincoli di fabbricazione, i metodi dell'edizione alla ripetitività della catena di montaggio.

Non si tratta solo di buon design, ma di una concezione più complessa del mondo delle cose e dell'abitare, di un'attitudine che mette insieme una rete di saperi che comprendono il fatto a mano e il fatto a macchina e ha relazioni con gli aspetti più antropologici dell'artigianato e dell'industria. Per trasferire la fenomenologia dell'arte nell'oggetto d'uso e rendere coincidenti le informazioni estetiche e funzionali, occorre innanzitutto saper scegliere i propri autori.

Praticare con loro quell'intensità delle relazioni professionali e affettive tra committente, impresa e designer che appartiene alla cultura del progetto. L'oggetto diventa così parte di un vasto e articolatissimo programma narrativo che, nel perseguire una propria personale immagine, ridefinisce la relazione tra produzione industriale e produzione del sapere.

IT'S NOT JUST ABOUT GOOD DESIGN

There is a special quality in some design firms, which is considering the aesthetical purpose as their basic foundation, also from an economic point of view. That's because cultural contents are more and more an expression of people's choices.

TATO's proposal is a newly structured and poetic model where the visual research goes together with the industrial experimentation, the philology of materials and techniques, both new and old, the discovery of new production geographies in order to build a catalogue in which the content stimulus and the edition methods are more privileged than the manufacturing limitations and the assembly line repetitiveness.

It's not just about good design: it's about a more complex vision of the world, of things and of living, it's about an attitude that brings together a network of knowledge including the hand-made and machine-made and that is related with the more anthropological aspects of craftsmanship and industry.

Choosing good authors is necessary to transfer the art phenomenology in the object and to make aesthetic and functional information be coincident. It's important to practice an intense professional and affective relationship between client, designer and company that belongs to the culture of the project.

So the object becomes a part of a vast and very articulate narrative program that, in pursuing a personal image, redefines the relationship between industrial production and knowledge production.



Corrado Corradi dell'Acqua

Corrado Corradi Dell'Acqua (Milano 1905 - Varese 1982) conosceva il diritto e praticava la scrittura e, senza far rumore, è diventato designer. Il suo cane bassotto si chiamava Azucena come l'avventura progettuale che Corradi aveva iniziato nel 1947 con altri due giovani intellettuali milanesi, Luigi Caccia Dominioni e Ignazio Gardella. Si divertiva a realizzare chintz con Luchino Visconti e gli piaceva lavorare la ceramica. Ha progettato lampade fatte col vetro dei tram di Milano e molti altri oggetti progettati a partire dalla casa con, in filigrana, un'idea precisa dell'abitare.

Corrado Corradi Dell'Acqua (Milan 1905 - Varese 1982) was a law expert, an amateur writer, and quietly became a designer. His dachshund's name was Azucena like the company Corradi had started in 1947 with two other young Milanese intellectuals, Luigi Caccia Dominioni and Ignazio Gardella. Corrado Corradi had fun designing chintz with Luchino Visconti and he liked ceramic. He designed lamps made with glass from Milan's tramcars and many other objects for the house, with a precise idea of living in mind.

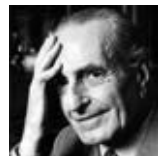

Ignazio Gardella

Ignazio Gardella (Milano, 1905 - Oleggio, 1999) è uno dei protagonisti dell'architettura italiana del Novecento. Si laurea prima in Ingegneria civile e poi in Architettura al Politecnico di Milano. Già prima della guerra svolge una serie di lavori importanti per l'alta borghesia piemontese e lombarda, una committenza che saprà interpretare in molti importanti progetti del periodo della Ricostruzione che lo vedrà in prima linea nella proposta di una nuova idea di architettura. Nel 1947, con Luigi Caccia Dominioni e Corrado Corradi Dell'Acqua, fonda Azucena. Fino agli anni Novanta, Gardella continuerà a disegnare mobili e oggetti d'arredo, oltre a portare avanti la straordinaria attività di architetto.

Ignazio Gardella (Milan, 1905 - Oleggio, 1999) was one of the leading figures in Italian twentieth-century architecture. He graduated first of all in Civil Engineering and then in Architecture at the Politecnico di Milano. Even before the war he had performed a series of jobs for the upper classes of Piedmont and Lombardia, clients whom he was able to interpret in many important projects in the period of Reconstruction when he was at the forefront in proposing a new idea of architecture. In 1947, he founded Azucena with Luigi Caccia Dominioni and Corrado Corradi Dell'Acqua. Until the 1990s, Gardella would continue designing furniture and accessories, as well as carrying on his extraordinary activity as architect.



Eugenio Gerli

Già sperimentatore di materiali nuovi come il feltro plastico e il compensato curvato prima di diventare architetto, Eugenio Gerli (Milano, 1923 - 2013) apre il suo studio nel 1949. Nel 1957 nasce la lunga e straordinaria collaborazione con Osvaldo e Fulgenzio Borsani e la Techno per cui progetta lo storico sistema operativo Graphic (1968) e altre icone come le sedute PS142 e S142. Dagli anni Settanta i figli, Enrico e Guido, affiancano l'attività paterna, occupandosi ora anche dell'Archivio.

Already experimenting with new materials such as plastic felt and curved plywood before becoming an architect, Eugenio Gerli (Milan, 1923 - 2013) opened his firm in 1949. 1957 marked the start of a long and extraordinary partnership with Osvaldo and Fulgenzio Borsani and Techno, for whom he designed the historic operating system Graphic (1968) and other icons such as the PS142 and S142 seats. In the 1970s, he was joined in the business by his sons, Enrico and Guido, who now also take care of the Archive.



Gio Ponti

Gio Ponti (Milano, 1891-1979) è una delle più importanti figure dell'architettura e delle arti del XX secolo. Si laurea a Milano nel 1921. Dal 1923 al 1930 è direttore artistico della Richard Ginori. Nel 1928 fonda la rivista "Domus", a cui seguiranno altre grandi imprese editoriali come "Stile". Sono della fine degli anni Venti le prime "case tipiche", dove al concetto di italianità si accosta l'interesse per le teorie razionaliste. Fin dalla prime edizioni partecipa alle Triennali di Milano. Con Antonio Fornaroli e Alberto Rosselli, nello studio di via Dezza che diventerà la sua casa, concepisce una straordinaria serie di progetti, espressione della teoria della "forma finita", nel campo dell'arredo con le "pareti organizzate", del design e dell'architettura.

Gio Ponti is one of the most important figures in twentieth-century architecture and arts. He graduated in Milan in 1921. From 1923 to 1930 he was artistic director of the Richard Ginori company. In 1928 he founded the magazine "Domus", which would be followed by other great publishing feats such as "Stile". Dating from the late 1920s are the "typical homes", which combined the concept of Italianness with an interest in rationalist theories. Right from the start, he took part in the Triennale design exhibitions in Milan. With Antonio Fornaroli and Alberto Rosselli, in the studio in Via Dezza which would become his home, he conceived an extraordinary series of projects, expressing his "finite form" theory in the fields of furniture with the "organized walls", design and architecture.



Alberto Rosselli

Alberto Rosselli (Palermo, 1921 - Milano, 1976) si laurea nell'immediato dopoguerra presso la Facoltà di Architettura del Politecnico di Milano. Dall'inizio della sua carriera e parallelamente alla sua attività di architetto, ha svolto studi teorici e ha progettato come designer, in campi differenti, da quello del product design a quello dell'arredamento, fino a quello dei trasporti. Nel 1953 inizia, in qualità di direttore, la pubblicazione della rivista "Stile Industria". Nel 1956 è Presidente della Associazione Italiana Disegno Industriale (ADI). La sua intensa attività di architetto si è svolta fin dall'inizio nello studio Ponti-Fornaroli-Rosselli alle cui realizzazioni ha partecipato a partire dagli anni '50.

Alberto Rosselli (Palermo, 1921 - Milan, 1976) graduated just after the end of the war from the Architecture Faculty of the Politecnico di Milano. From the start of his career and in parallel to his activity as architect, he carried out theoretical studies and worked as a designer in different fields, from product design to furniture, to transport. In 1953, as director, he brought out the magazine "Stile Industria". In 1956 he was Chairman of the Italian Association of Industrial Design (ADI). His intense work as architect was carried out in the Ponti-Fornaroli-Rosselli studio, becoming a co-creator in its projects in the 1950s.



Antonia Astori

Antonia Astori nasce a Melzo (Milano) nel 1940. Si laurea in Industrial e Visual Design all'Athenaeum di Losanna nel 1966. Dal 1968 collabora in qualità di designer con l'azienda italiana Driade. Realizza importanti progetti di sistemi e di mobili e contribuisce a definire l'immagine aziendale con allestimenti ed esposizioni. All'attività di designer affianca quella di architetto d'interni con progetti per abitazioni, uffici, showroom, negozi.

Antonia Astori was born in Melzo (Milan) in 1940. She graduated in Industrial and Visual Design at the Athenaeum of Lausanne in 1966. Since 1968 she has worked as a designer for the Italian company Driade, creating some important system and furniture designs and helping to shape the corporate image with her outfitting and exhibitions. Her activity as a designer goes alongside her work as interior designer, with projects for houses, offices, showrooms and stores.



Lorenza Bozzoli

Lorenza Bozzoli è nata a Milano e ha studiato all'Accademia di Belle Arti di Brera. Dal 1985 ha iniziato a lavorare come stilista, tra gli altri, per Fiorucci, Basile, Plein Sud, Sergio Rossi, Camper. Dal 1996 si dedica con passione al design industriale, lavorando per Antiquità, Viceversa, Alessi, Dilmos, Dedon, Moooi. Ha partecipato a importanti mostre in Italia e all'estero. Vive e lavora a Milano nel suo studio di design.

Lorenza Bozzoli was born in Milan, where she studied at the Accademia di Belle Arti di Brera. In 1985 she began working as a fashion designer for Fiorucci, Basile, Plein Sud, Sergio Rossi and Camper among others. In 1996 she became passionately involved in industrial design for Antiquità, Viceversa, Alessi, Dilmos, Dedon and Moooi. She has participated in important exhibitions in Italy and abroad. She lives and works in Milan where she has her own design studio.



Giulia e Guido Guarnieri

Giulia e Guido Guarnieri amano Milano e il design degli anni Cinquanta e Sessanta. Dopo una laurea al Politecnico di Milano, hanno intrapreso diversi percorsi professionali, anche a livello internazionale, tra design, video arte e marketing. Attualmente Giulia è Brand manager di un marchio di abbigliamento italiano e Guido è art director per un'azienda di design.

Giulia and Guido Guarnieri are fond of Milan and 1950s and 60s design. After graduating from the Politecnico di Milano, they became involved in various professional projects regarding design, video art and marketing, both in Italy and in Europe. Giulia is currently a brand manager for an Italian fashion company and Guido is an art director for a design company.



Hisham Kulhanek

Hisham Kulhanek è nato a Praga nel 1958. Nel 1970 la sua famiglia si trasferisce ad Amsterdam. Dopo gli studi alla Delft University of Technology decide di trasferirsi a Milano dove inizia una lunga collaborazione col designer giapponese Makio Hasuike. Ultimamente lavora con un team multidisciplinare a Milano prevalentemente su progetti di industrial design. Ha insegnato all'Istituto Europeo di Design (IED) di Milano. Ha tenuto workshops alla Domus Academy e al Master di Design Strategico del Politecnico di Milano.

Hisham Kulhanek was born in Prague in 1958. In 1970 he moved to Amsterdam with his family. After studying at the Delft University of Technology, he decided to move to Milan where he started a long partnership with the Japanese designer Makio Hasuike. Now he runs a multidisciplinary studio focused on product design. He has been a teacher at the Istituto Europeo di Design (IED) in Milan, and has run some workshops at the Domus Academy and at the Politecnico di Milano for the Master's degree in Strategic Design.



Gianluigi Landoni

Gianluigi Landoni è architetto e designer. Si laurea al Politecnico di Milano. Dopo diverse esperienze in studi di architettura e industrial design, dal 1994 svolge l'attività professionale in proprio, collaborando con diverse aziende di design. Ha partecipato a mostre e concorsi per opere pubbliche e private, ricevendo premi e riconoscimenti. Ha svolto attività didattica presso l'Istituto Europeo di Design (IED) di Milano.

Gianluigi Landoni is an architect and designer. He graduated from the Politecnico di Milano. After many experiences in architecture and industrial design studios, since 1994 he has worked as a freelance architect alongside numerous design companies. He has participated in various exhibitions and contests for both public and private works, receiving awards and commendations. He has been a teacher at the Istituto Europeo del Design (IED) in Milan.



Matteo Nunziati

Matteo Nunziati è considerato uno degli architetti e designer internazionali più importanti della sua generazione. I suoi progetti, esclusivi e valorizzati dalla sapiente selezione di materiali e arredi, solitamente scelti tra le eccellenze produttive del design Made in Italy, sono stati pubblicati nelle maggiori riviste di settore italiane e internazionali. Numerosi e prestigiosi i riconoscimenti ricevuti per i prodotti di design da lui disegnati; la sua solida esperienza ha poi condotto Nunziati a svolgere attività didattica presso importanti istituzioni come Domus Academy, la National Taipei University of Technology, l'IDI Interior Design Institute di Milano e la Tshinghua University Shenzhen in Cina.

Matteo Nunziati is considered one of the most influential international architects and designers of his generation. He received numerous important awards for his works in product design; his projects, exclusive and enhanced by the skillful selection of materials and furnishings, usually chosen from the production excellence of Made in Italy design, have been published in the major Italian and international magazines. His solid experience led Nunziati carry out teaching activities at important institutions such as Domus Academy, the National Taipei University of Technology, the IDI Interior Design Institute of Milan and the Tshinghua University Shenzhen in China.



ALZABILE
10



ANITA
14



ARENZANO
16



BEGHINA
32



BIBA
42



COPPA APERTA
56



DE-LUX
64



GALLERIA
74



ICONES
80



JIL
84



LADY V
86



LEA
90



LUNA
94



NETTA
106



OLLY
110



ORSOLA
118

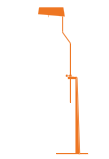

OTTAVIA
120



QUATTROLATI
122



SIDEREA
124



VOX
126



WALLIE
130



ANGOLO
148



LIDO
152



MONTECARLO
156



PIEDI REGOLABILI
158



TRECENTOESSANTA
162



PESTELLO
166



CERAMICS
168



LIGHTING



ALZABILE

DESIGNED BY **IGNAZIO GARDELLA** • 1948



DETAILS

Type: floor lamp
 Materials: marble / brass / aluminum
 Weight: 5,50 kg
 Insulation: class II / IP20
 Bulbs: 1xLED max 8W E27-220V / E26-110V

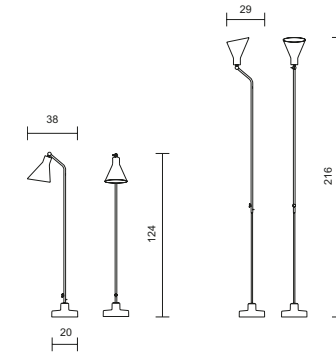

FINISHINGS

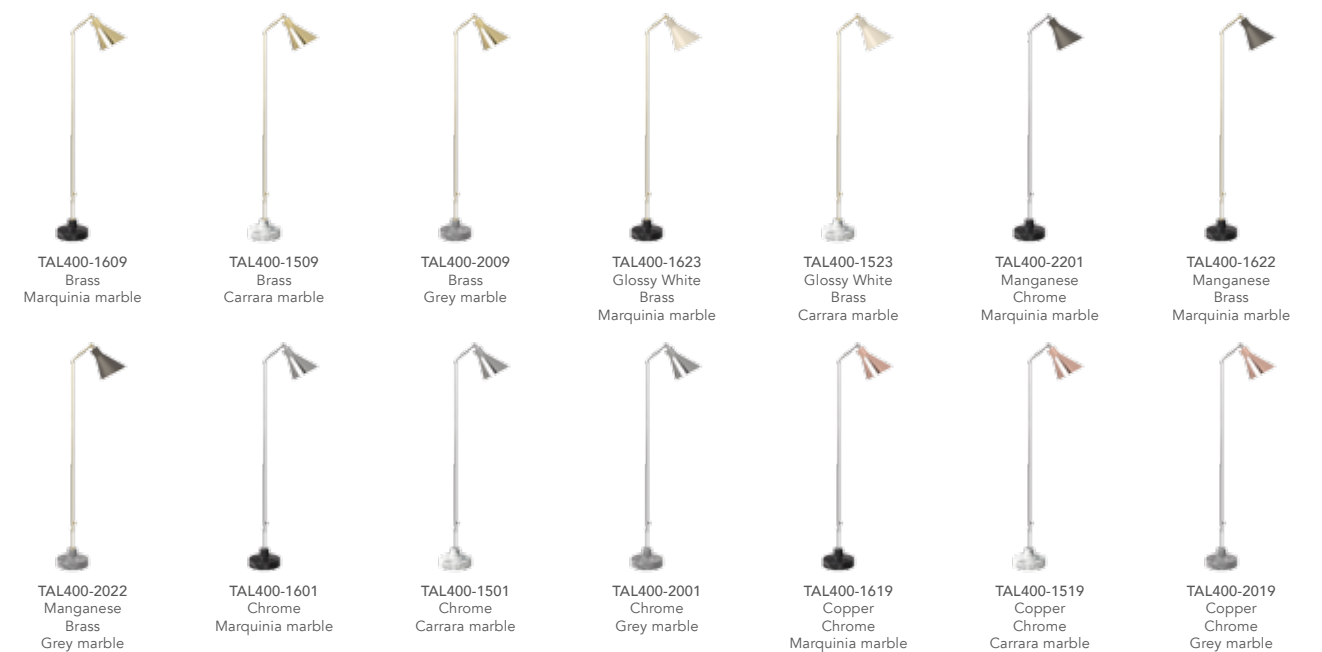



ANITA

DESIGNED BY **LORENZA BOZZOLI** • 2016



DETAILS

Type: table lamp
Materials: marble / brass / glass
Weight: 7,50 kg
Insulation: class II / IP20
Bulbs: 3xLED max 5W E14-220 / E12-110V

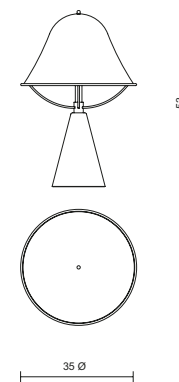

FINISHINGS



TAN300-0115
Carrara marble
Chrome



TAN300-1217
Persian Grey marble
Satin Dark Chrome



TAN300-1318
Emperador marble
Satin Brass

ARENZANO

DESIGNED BY **IGNAZIO GARDELLA** • 1956



DETAILS

Type: table lamp
Materials: brass / glass
Weight: 3,80 Kg
Insulation: class II / IP20
Bulbs: 3xLED max 5W E14-220V / E12-110V

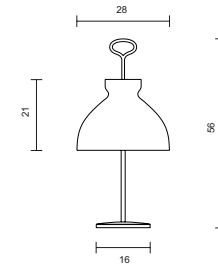

FINISHINGS



TAL310-0940
Brass



TAL310-0140
Chrome



TAL310-0540
Satin Nickel



TAL310-1440
Satin Bronze



ARENZANO BASSA

DESIGNED BY **IGNAZIO GARDELLA** • 1956



DETAILS

Type: table lamp
Materials: brass / glass
Weight: 2,40 Kg
Insulation: class II / IP20
Bulbs: 3xLED max 5W E14-220V / E12-110V

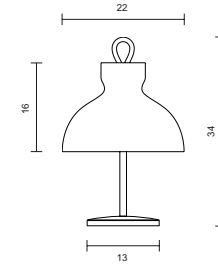

FINISHINGS



TAL310-0940
Brass



TAL310-0140
Chrome



TAL310-0540
Satin Nickel



TAL310-1440
Satin Bronze



Segreti per il successo
365

Enrica Rodolfo Ritratto di un Principe
Luis Sepúlveda PALAGONIA EXPRESS

ENRICO VAIME Gente perbene

ANIMA

ANIMA

ANIMA

ANIMA

ANIMA

ANIMA

ANIMA

ANIMA

ANIMA

ANIMA

THE LANDSCAPE OF MAN

PIRELLA GÖTTSCHE LOWE

PIRELLA GÖTTSCHE LOWE

PIRELLA GÖTTSCHE LOWE

GIARDINI DI PUGLIA

GIARDINI SEGRETI

VILLE DELLA PROVINCIA DI MILANO

VILLE DELLA PROVINCIA DI MILANO

VILLE DELLA PROVINCIA DI MILANO

VILLE DELLA PROVINCIA DI MILANO

VILLE DELLA PROVINCIA DI MILANO

VILLE DELLA PROVINCIA DI MILANO

VILLE DELLA PROVINCIA DI MILANO

ARENZANO TRE FIAMME

DESIGNED BY **IGNAZIO GARDELLA** • 1963



DETAILS

Type: table lamp
Materials: marble / brass / glass
Weight: 15,00 Kg
Insulation: class II / IP20
Bulbs: 9xLED max 5W E14-220V / E12-110V

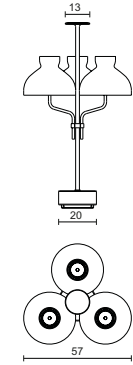

FINISHINGS



TAR320-1509
Brass
Carrara marble



TAR320-1501
Chrome
Carrara marble



TAR320-1505
Satin Nickel
Carrara marble



TAR320-1514
Satin Bronze
Carrara marble



TAR320-1609
Brass
Marquinia marble



TAR320-1601
Chrome
Marquinia marble



TAR320-1605
Satin Nickel
Marquinia marble



TAR320-1614
Satin Bronze
Marquinia marble



ARENZANO TRE FIAMME

DESIGNED BY **IGNAZIO GARDELLA** • 1963



DETAILS

Type: floor lamp
Materials: marble / brass / glass
Weight: 19,00 Kg
Insulation: class II / IP20
Bulbs: 9xLED max 5W E14-220V / E12-110V

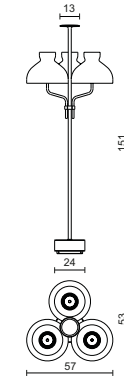

FINISHINGS



TAR400-1509
Brass
Carrara marble



TAR400-1501
Chrome
Carrara marble



TAR400-1505
Satin Nickel
Carrara marble



TAR400-1514
Satin Bronze
Carrara marble



TAR400-1609
Brass
Marquinia marble



TAR400-1601
Chrome
Marquinia marble



TAR400-1605
Satin Nickel
Marquinia marble



TAR400-1614
Satin Bronze
Marquinia marble



BEGHINA TAVOLO

DESIGNED BY **GIULIA & GUIDO GUARNIERI** • 2011



DETAILS

Type: table lamp
Materials: brass / aluminum
Weight: 2,00 Kg
Insulation: class II / IP20
Bulbs: 1xLED max 3W G9 110-220V

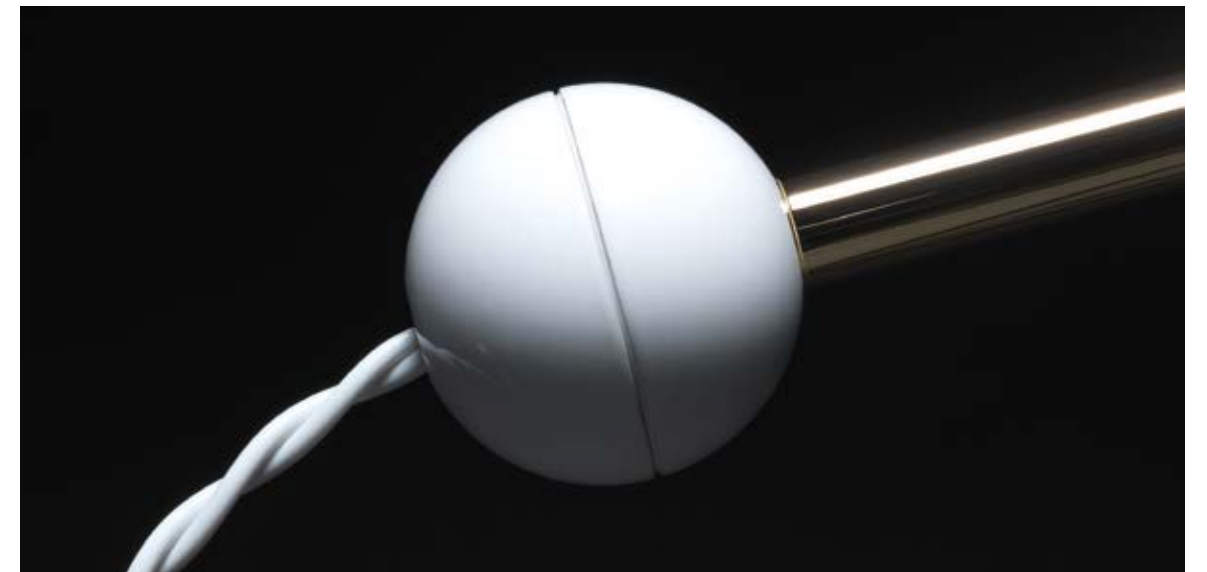
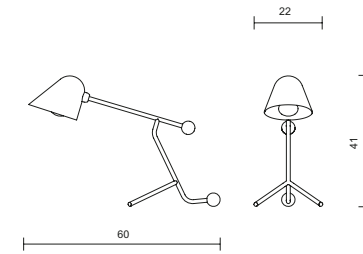

FINISHINGS



TBE300-0923
Brass
Glossy White

TBE300-0924
Brass
Glossy Black

TBE300-0125
Chrome
Textured White

TBE300-0126
Chrome
Textured Black

BEGHINA TERRA

DESIGNED BY **GIULIA & GUIDO GUARNIERI** • 2011



DETAILS

Type: floor lamp
Materials: brass / aluminum
Weight: 3,50 Kg
Insulation: class II / IP20
Bulbs: 1xLED max 3W G9 110-220V

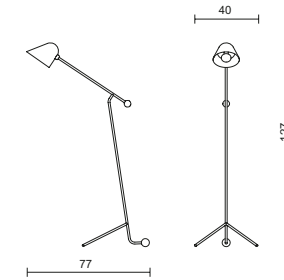

FINISHINGS



TBE400-0923
Brass
Glossy White



TBE400-0924
Brass
Glossy Black



TBE400-0125
Chrome
Textured White



TBE400-0126
Chrome
Textured Black

BEGHINA APPLIQUE

DESIGNED BY GIULIA & GUIDO GUARNIERI • 2011



DETAILS

Type: wall lamp
Materials: brass / aluminum
Weight: 1,00 Kg
Insulation: class I / IP20
Bulbs: 1xLED max 3W G9 110-220V

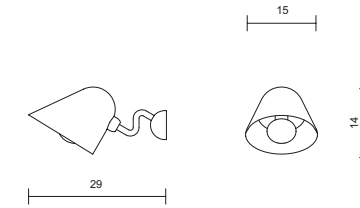

FINISHINGS



TBE200-0923
Brass
Glossy White



TBE200-0924
Brass
Glossy Black



TBE200-0125
Chrome
Textured White



TBE200-0126
Chrome
Textured Black

BEGHINA DUE BRACCI

DESIGNED BY **GIULIA & GUIDO GUARNIERI** • 2011



DETAILS

Type: wall lamp
Materials: brass / aluminum
Weight: 2,50 Kg
Insulation: class I / IP20
Bulbs: 2xLED max 3W G9 110-220V

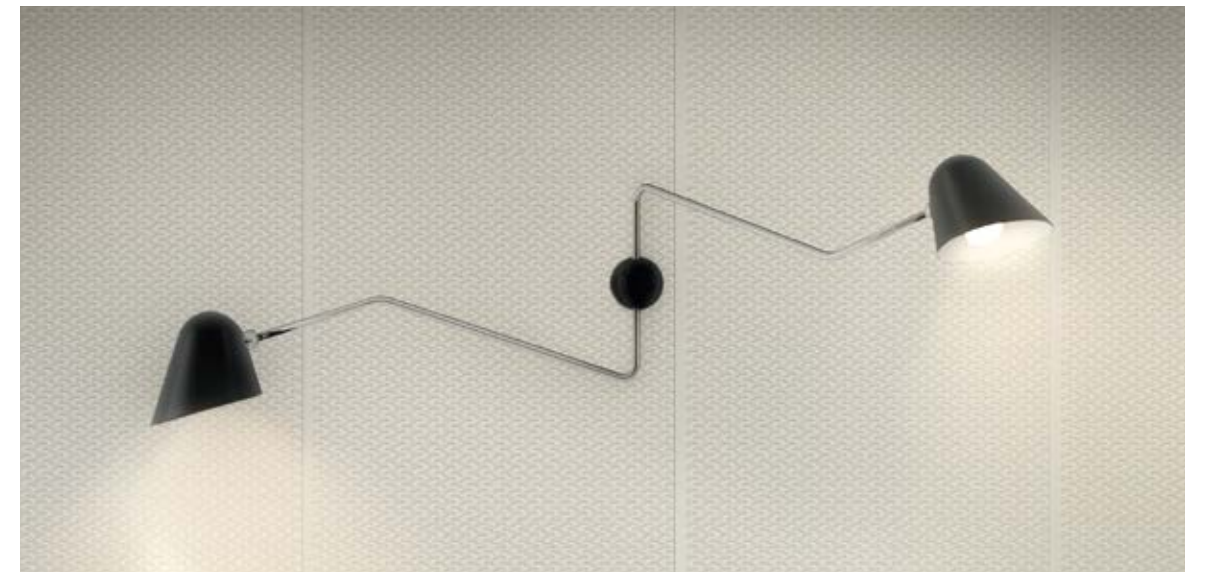
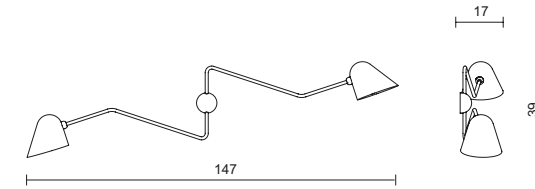

FINISHINGS



TBE210-0923
Brass
Glossy White

TBE210-0924
Brass
Glossy Black

TBE210-0125
Chrome
Textured White

TBE210-0126
Chrome
Textured Black

BEGHINA SOSPENSIONE

DESIGNED BY GIULIA & GUIDO GUARNIERI • 2011



DETAILS

Type: ceiling lamp
Materials: brass / aluminum
Weight: 1,50 Kg
Insulation: class I / IP20
Bulbs: 1xLED max 3W G9 110-220V

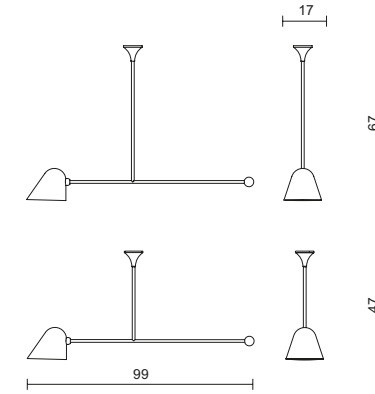

FINISHINGS



BIBA TAVOLO

DESIGNED BY **LORENZA BOZZOLI** • 2017



DETAILS

Type: table lamp
Materials: brass / aluminum / glass
Weight: 6,00 kg
Insulation: class II / IP20
Bulbs: 1xLED max 5W E14-220V / E12-110V
1xLED max 8W E27-220V / E26-110V

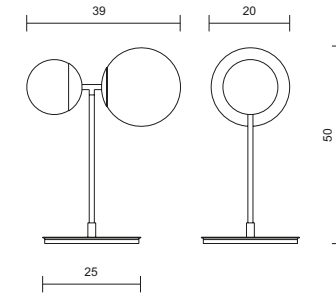

FINISHINGS



TBI300-1340
Satin Brass

TBI300-0540
Satin Nickel

TBI300-3540
Matte Black



BIBA TERRA

DESIGNED BY **LORENZA BOZZOLI** • 2017



DETAILS

Type: floor lamp
Materials: brass / aluminum / glass
Weight: 6,50 kg
Insulation: class II / IP20
Bulbs: 1xLED max 5W E14-220V / E12-110V
1xLED max 8W E27-220V / E26-110V

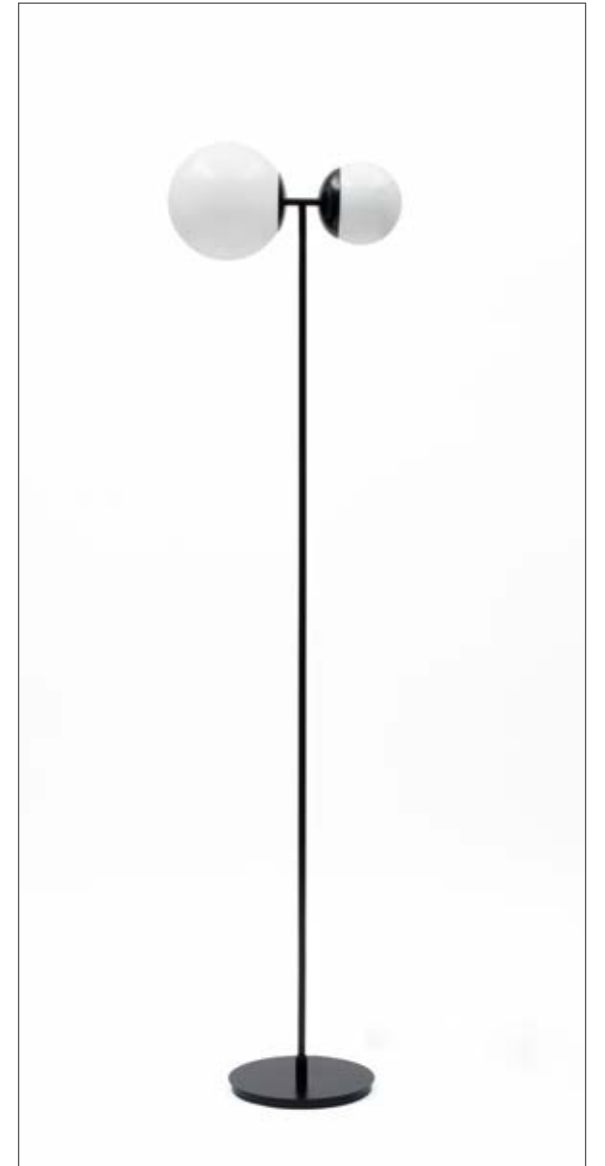
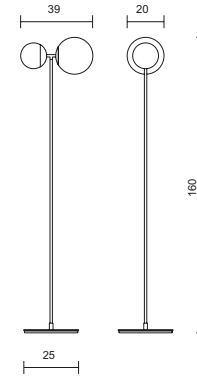

FINISHINGS



TBI400-1340
Satin Brass



TBI400-0540
Satin Nickel



TBI400-3540
Matte Black



BIBA APPLIQUE

DESIGNED BY **LORENZA BOZZOLI** • 2017



DETAILS

Type: wall lamp
Materials: brass / aluminum / glass
Weight: 1,00 kg
Insulation: class I / IP20
Bulbs: 1xLED max 5W E14-220V / E12-110V
1xLED max 8W E27-220V / E26-110V

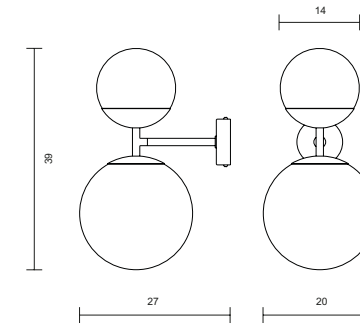

FINISHINGS

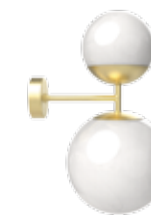

TBI200-1340
Satin Brass



TBI200-0540
Satin Nickel



TBI200-3540
Matte Black



BIBA SOSPENSIONE

DESIGNED BY **LORENZA BOZZOLI** • 2017



DETAILS

Type: ceiling lamp
 Materials: brass / aluminum / glass
 Weight: 3,00 / 3,50 / 4,00 / 4,50 Kg
 Insulation: class I / IP20
 Bulbs: 1xLED max 5W E14-220V / E12-110V
 1xLED max 8W E27-220V / E26-110V

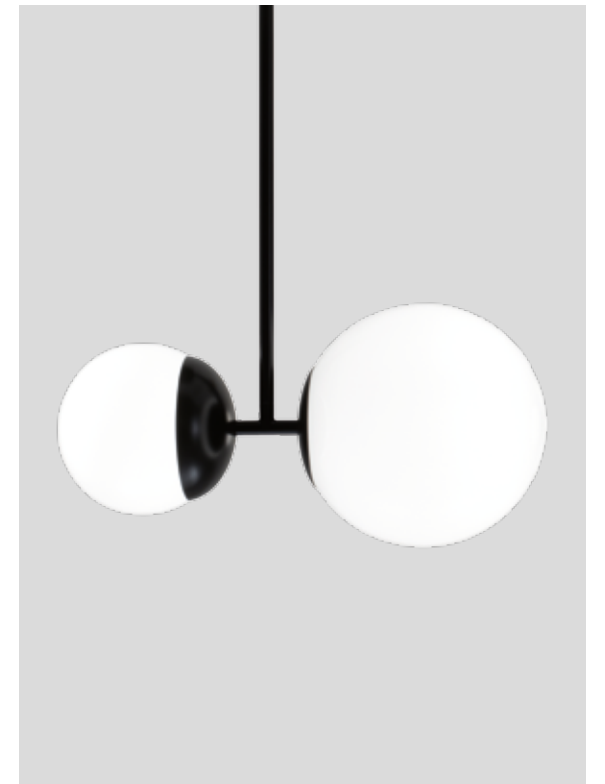
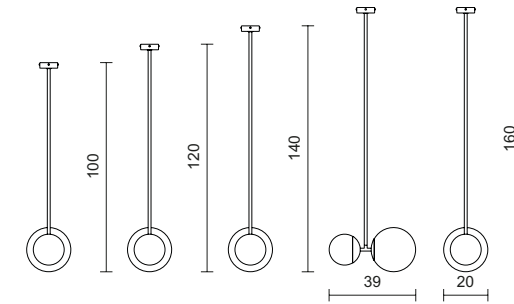

FINISHINGS



TBI100-1340
100cm
Satin Brass



TBI100-0540
100cm
Satin Nickel



TBI100-3540
100cm
Matte Black



TBI120-1340
120cm
Satin Brass



TBI120-0540
120cm
Satin Nickel



TBI120-3540
120cm
Matte Black



TBI140-1340
140cm
Satin Brass



TBI140-0540
140cm
Satin Nickel



TBI140-3540
140cm
Matte Black



TBI160-1340
160cm
Satin Brass



TBI160-0540
160cm
Satin Nickel



TBI160-3540
160cm
Matte Black

COPPA APERTA APPLIQUE

DESIGNED BY **IGNAZIO GARDELLA** & **CORRADO CORRADI DELL'ACQUA** • 1954



DETAILS

Type: wall lamp
Materials: brass / glass
Weight: 1,50 kg
Insulation: class I / IP20
Bulbs: 1xLED max 8W E27-220V / E26-110V

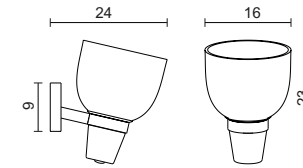

FINISHINGS



TCA200-0924
Brass
Glossy Black

TCA200-0124
Chrome
Glossy Black

TCA200-0524
Satin Nickel
Glossy Black

TCA200-0921
Brass
Silver

TCA200-0121
Chrome
Silver

TCA200-0521
Satin Nickel
Silver



COPPA APERTA PIANTANA

DESIGNED BY **IGNAZIO GARDELLA** & **CORRADO CORRADI DELL'ACQUA** • 1954

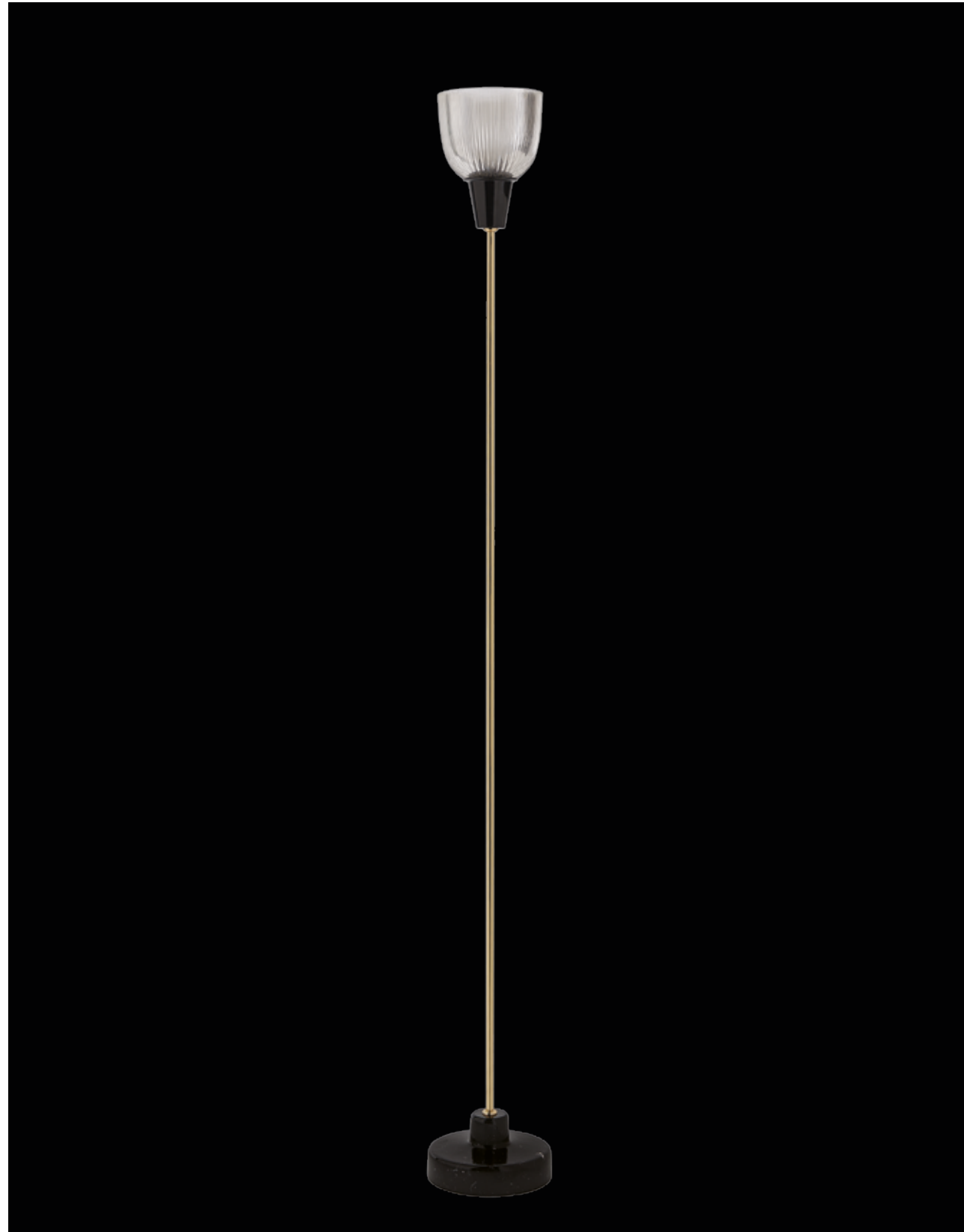

DETAILS

Type: floor lamp
Materials: brass / glass
Weight: 6,50 Kg
Insulation: class II / IP20
Bulbs: 1xLED max 8W E27-220V / E26-110V



FINISHINGS



TCA400-1609
Brass
Marquinia marble



TCA400-1601
Chrome
Marquinia marble



TCA400-1509
Brass
Carrara marble



TCA400-1501
Chrome
Carrara marble



DE-LUX "A"

DESIGNED BY **GIO PONTI** • 1955



DETAILS

Type: floor lamp
Materials: aluminum / iron / polypropylene
Weight: 5,00 / 6,00 Kg
Insulation: class II / IP20
Bulbs: 1xLED max 20W E27-220V / E26-110V

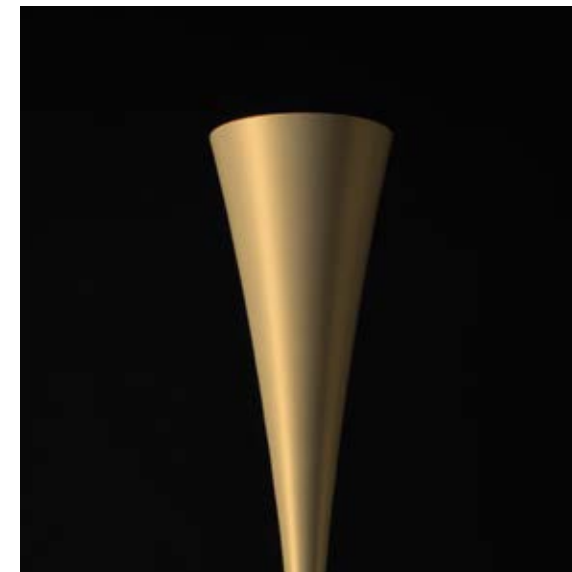
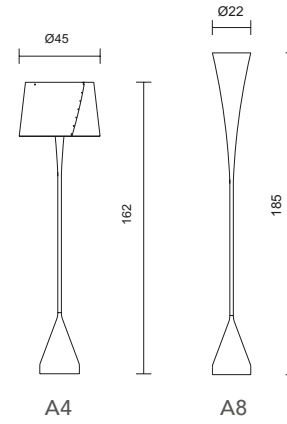

FINISHINGS



DE-LUX "B"

DESIGNED BY GIO PONTI • 1955



DETAILS

Type: floor lamp
Materials: aluminum / iron / polypropylene
Weight: 3,50 / 4,50 Kg
Insulation: class II / IP20
Bulbs: 1xLED max 20W E27-220V / E26-110V

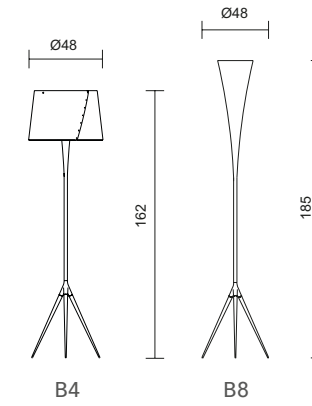

FINISHINGS





DE-LUX "D"

DESIGNED BY **GIO PONTI** • 1955



DETAILS

Type: floor lamp
Materials: aluminum / iron / polypropylene
Weight: 8,50 / 7,50 Kg
Insulation: class II / IP20
Bulbs: 1xLED max 20W E27-220V / E26-110V

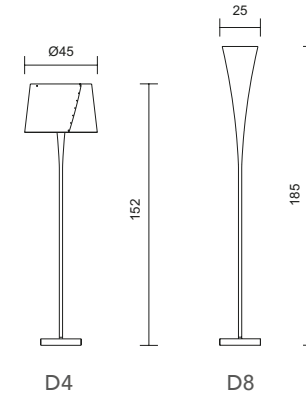

FINISHINGS



DE-LUX D4
TDD440-3365
Matte White
Orange tiles



DE-LUX D4
TDD440-3765
Matte White
Blue tiles



DE-LUX D8
TDD410-3325
Matte White
Orange tiles



DE-LUX D8
TDD410-3725
Matte White
Blue tiles



GALLERIA

DESIGNED BY **IGNAZIO GARDELLA** • 1958



DETAILS

Type: wall lamp
Materials: brass / glass
Weight: 2,00 / 3,50 / 5,50 / 7,00 / 8,50 Kg
Insulation: class I / IP20
Bulbs: 1xLED max 8W E27-220V / E26-110V
(each shade)

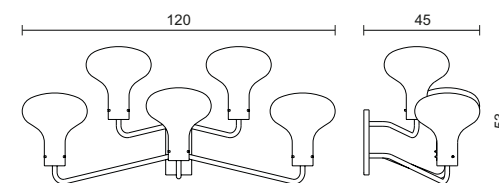
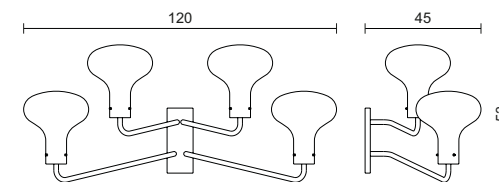
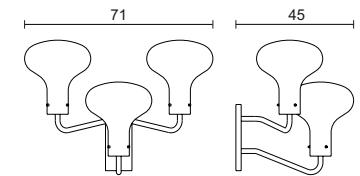
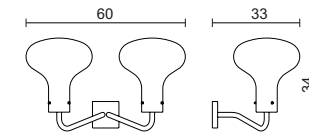
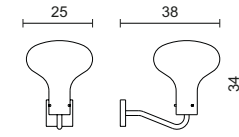



TGA210-0940
1 light
Brass



TGA210-0140
1 light
Chrome



TGA210-0540
1 light
Satin Nickel



TGA210-1440
1 light
Satin Bronze



TGA220-0940
2 lights
Brass



TGA220-0140
2 lights
Chrome



TGA220-0540
2 lights
Satin Nickel



TGA220-1440
2 lights
Satin Bronze



TGA230-0940
3 lights
Brass



TGA230-0140
3 lights
Chrome



TGA230-0540
3 lights
Satin Nickel



TGA230-1440
3 lights
Satin Bronze



TGA240-0940
4 lights
Brass



TGA240-0140
4 lights
Chrome



TGA240-0540
4 lights
Satin Nickel



TGA240-1440
4 lights
Satin Bronze



TGA250-0940
5 lights
Brass



TGA250-0140
5 lights
Chrome



TGA250-0540
5 lights
Satin Nickel



TGA250-1440
5 lights
Satin Bronze





ICONES

DESIGNED BY **LORENZA BOZZOLI** • 2019



DETAILS

Type: table lamp
Materials: aluminum / brass / plastic
Weight: 8,00 Kg
Insulation: class II / IP20
Bulbs: 3xLED max 8W E27-220V / E26-110V

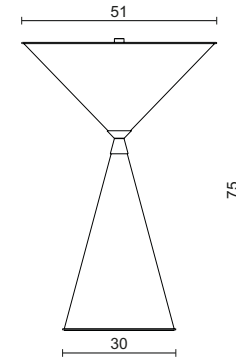

FINISHINGS



TIC300-0513
Satin Nickel
Satin Brass



TIC300-0522
Satin Nickel
Manganese





DETAILS

Type: table lamp
 Materials: marble / brass / glass
 Weight: 7,50 kg
 Insulation: class II / IP20
 Bulbs: 3xLED max 5W E14-220V / E12-110V

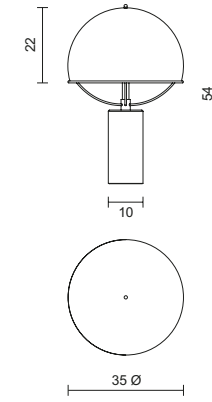

FINISHINGS



TJL300-1315
Carrara marble
Satin Brass



TJL300-0115
Carrara marble
Chrome



TJL300-1215
Carrara marble
Satin Dark Chrome

LADY V

DESIGNED BY **ATELIER TATO** • 2015



DETAILS

Type: floor lamp
Materials: brass / aluminum / iron
Weight: 6,50 Kg
Insulation: class II / IP20
Bulbs: 1xLED max 8W E27-220V / E26-110V

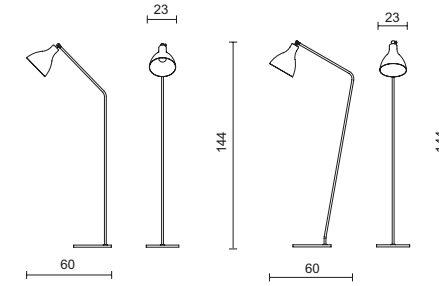

FINISHINGS



TLV400-0923
Brass
Glossy White



TLV400-0924
Brass
Glossy Black



TLV400-0125
Chrome
Textured White



TLV400-0126
Chrome
Textured Black



TLV410-0923
Brass
Glossy White



TLV410-0924
Brass
Glossy Black



TLV410-0125
Chrome
Textured White



TLV410-0126
Chrome
Textured Black

LADY V PIANTANA

DESIGNED BY **ATELIER TATO** • 2015



DETAILS

Type: floor lamp
Materials: brass / aluminum / iron
Weight: 6,50 Kg
Insulation: class II / IP20
Bulbs: 1xLED max 8W E27-220V / E26-110V

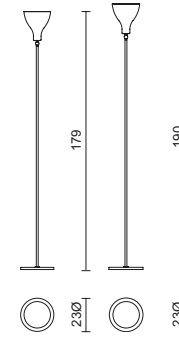

FINISHINGS





DETAILS

Type: table lamp
 Materials: marble / glass
 Weight: 11,00 Kg
 Insulation: class II / IP20
 Bulbs: 1xLED max 8W E27-220V / E26-110V

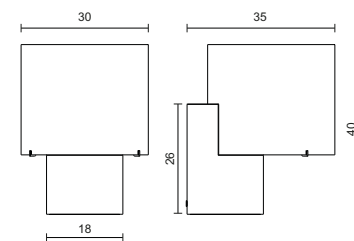

FINISHINGS



TLE300-1540
 Carrara Marble
 White Glass



TLE300-5040
 Portoro Marble
 White Glass



LUNA ORIZZONTALE

DESIGNED BY **GIO PONTI** • 1957



DETAILS

Type: floor lamp
Materials: brass / steel / plastic
Weight: 3,50 kg
Insulation: class II / IP20
Bulbs: 3xLED max 8W E27-220V / E26-110V

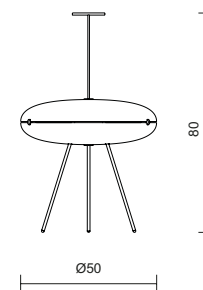

FINISHINGS



TLU400-1365
Satin Brass
Satin White plastic



TLU400-0565
Satin Nickel
Satin White plastic



TLU400-0967
Brass
Glossy White & Blue plastic



LUNA VERTICALE

DESIGNED BY **GIO PONTI** • 1957



DETAILS

Type: floor lamp
Materials: brass / steel / plastic
Weight: 4,00 kg
Insulation: class II / IP20
Bulbs: 4xLED max 5W E14-220V / E12-110V

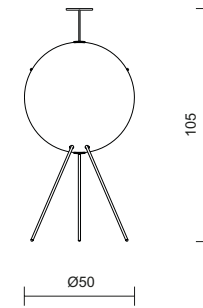

FINISHINGS



TLU410-1365
Satin Brass
Satin White plastic



TLU410-0565
Satin Nickel
Satin White plastic



TRIENNALE MILANO 1957
© GIO PONTI ARCHIVES

LUNA SOSPENSIONE

DESIGNED BY GIO PONTI • 2017



DETAILS

Type: ceiling lamp
Materials: brass / steel / plastic
Weight: 3,00 kg
Insulation: class II / IP20
Bulbs: 3xLED max 12W E27-220V / E26-110V

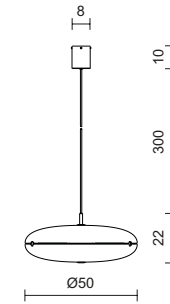

FINISHINGS



TLU100-1365
Satin Brass
Satin White plastic

TLU100-0565
Satin Nickel
Satin White plastic



NETTA PIANTANA

DESIGNED BY **ANTONIA ASTORI** • 2016



DETAILS

Type: floor lamp
Materials: iron / brass / glass
Weight: 8,00 kg
Insulation: class II / IP20
Bulbs: 1xLED max 8W E27-220V / E26-110V

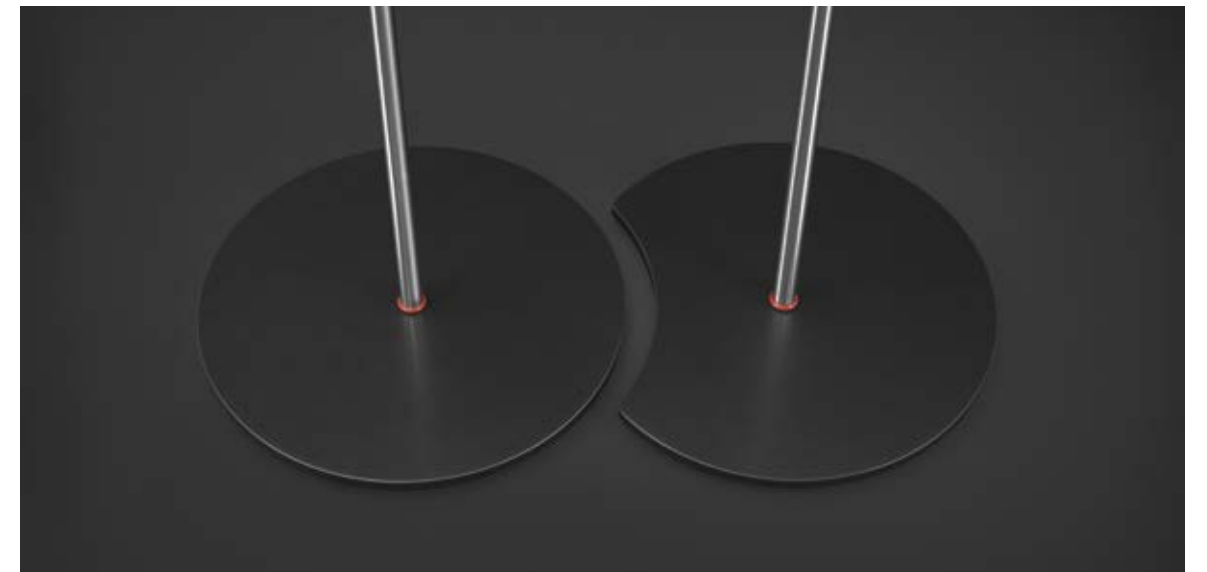
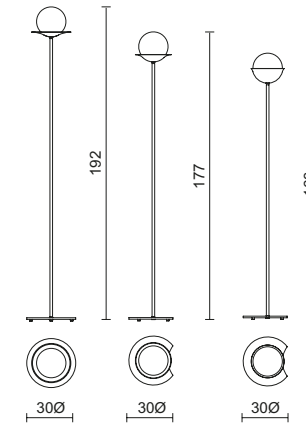

FINISHINGS



NETTA SOSPENSIONE

DESIGNED BY **ANTONIA ASTORI** • 2017



DETAILS

Type: ceiling lamp
Materials: iron / brass / glass
Weight: 2,00 kg
Insulation: class II / IP20
Bulbs: 1xLED max 8W E27-220V / E26-110V

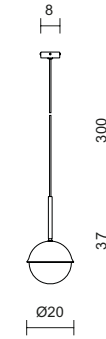

FINISHINGS



TNE100-3401
Black Chrome

OLLY TAVOLO

DESIGNED BY **LORENZA BOZZOLI** • 2016



DETAILS

Type: table lamp
Materials: brass / glass
Weight: 1,50 / 3,50 Kg
Insulation: class II / IP20
Bulbs: 1xLED max 3W G9 110-220V

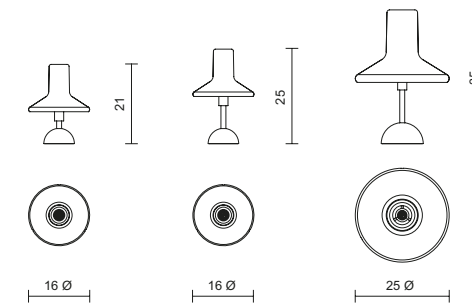

FINISHINGS



OLLY APPLIQUE

DESIGNED BY **LORENZA BOZZOLI** • 2017



DETAILS

Type: wall lamp
Materials: brass / glass
Weight: 0,70 kg
Insulation: class I / IP20
Bulbs: 1xLED max 5W E14-220V / E12-110V

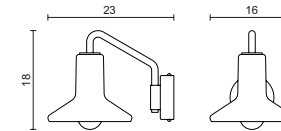

FINISHINGS



TOL200-1341
Satin Brass

TOL200-0141
Chrome

TOL200-1441
Satin Bronze



OLLY SOSPENSIONE

DESIGNED BY **LORENZA BOZZOLI** • 2017



DETAILS

Type: ceiling lamp
Materials: brass / glass
Weight: 0,50 kg
Insulation: class I / IP20
Bulbs: 1xLED max 5W E14-220V / E12-110V

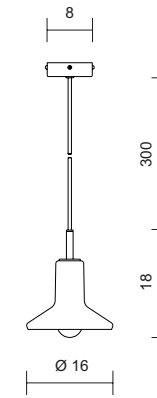

FINISHINGS



TOL100-1341
Satin Brass



TOL100-0141
Chrome



TOL100-1441
Satin Bronze

ORSOLA

DESIGNED BY **LORENZA BOZZOLI** • 2015



DETAILS

Type: table lamp
Materials: marble / brass / fabric
Weight: 8,00 kg
Insulation: class II / IP20
Bulbs: 3xLED max 5W E14-220V / E12-110V

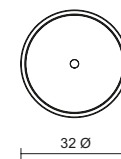
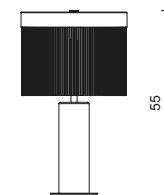

FINISHINGS



OTTAVIA

DESIGNED BY GIANLUIGI LANDONI • 2011



DETAILS

Type: floor lamp
Materials: iron / wood / brass / aluminum
Weight: 7,00 kg
Insulation: class II / IP20
Bulbs: 1xLED max 8W E27-220V / E26-110V

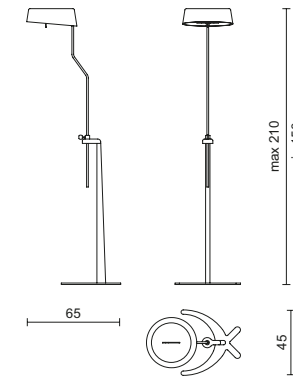

FINISHINGS



TOT400-0526
Textured Black
Canaletto Walnut Wood
Satin Nickel

QUATTROLATI

DESIGNED BY HISHAM KULHANEK • 2011



DETAILS

Type: table lamp
Materials: marble / aluminum
Weight: 10,00 kg
Insulation: class II / IP20
Bulbs: 1xLED max 3W G9 110-220V

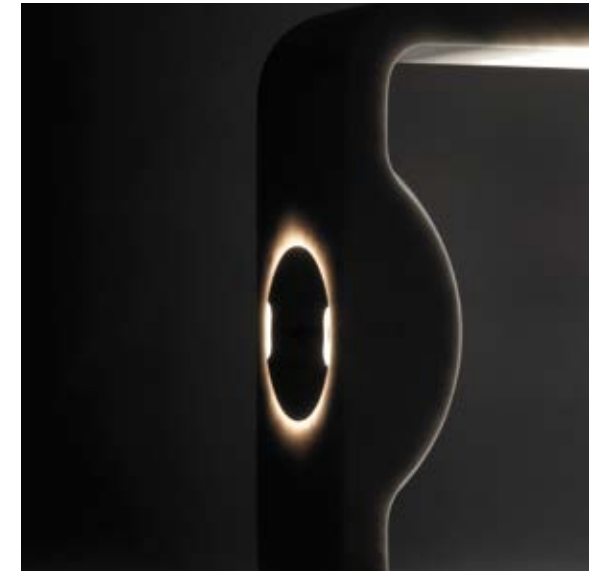
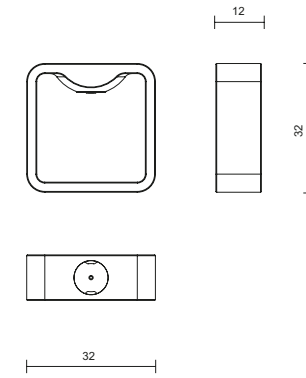

FINISHINGS



TQU300-1505
Carrara Marble
Satin Nickel

SIDERA

DESIGNED BY **ALBERTO ROSSELLI** • 1969



DETAILS

Type: table lamp
Materials: iron / glass
Weight: 5,00 kg
Insulation: class II / IP20
Bulbs: 1xLED max 8W E27-220V / E26-110V

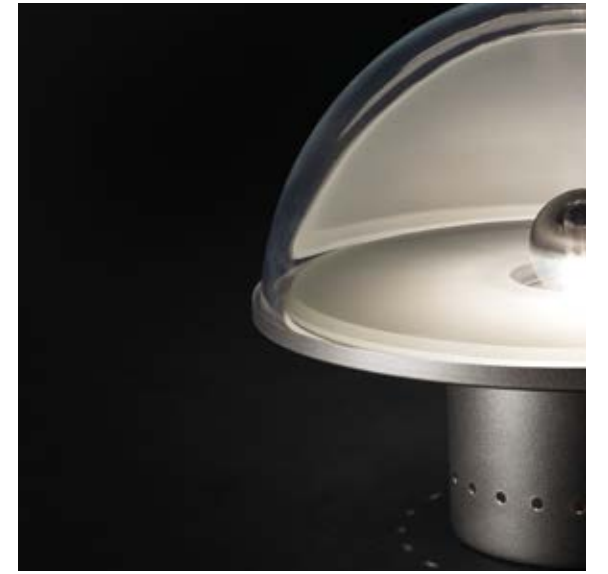
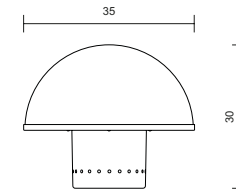

FINISHINGS



TSI300-2244
Manganese
Crystal



TSI300-3344
Orange
Crystal



TSI300-3944
Green
Crystal



DETAILS

Type: table lamp
 Materials: marble / brass or aluminum
 Weight: 2,50 kg
 Insulation: class II / IP20
 Bulbs: 1xLED max 8W E27-220V / E26-110V

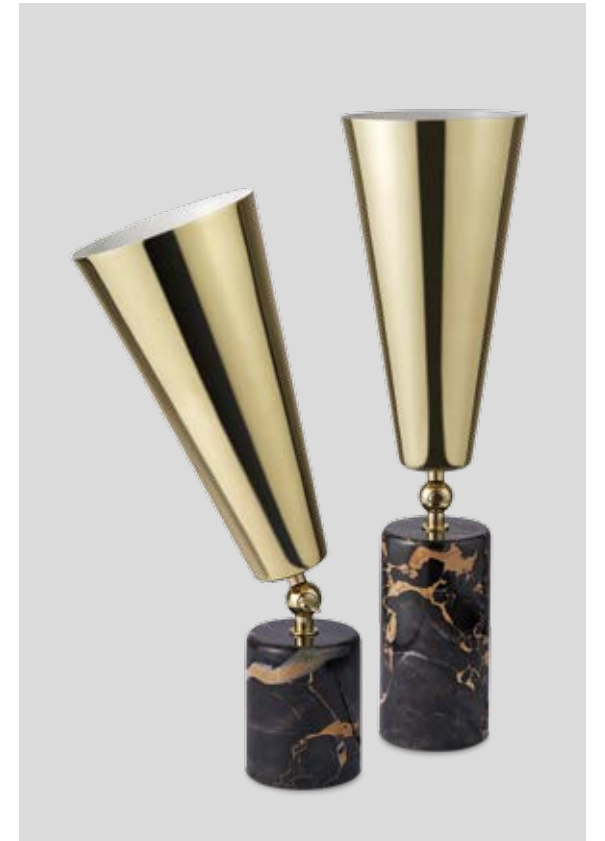
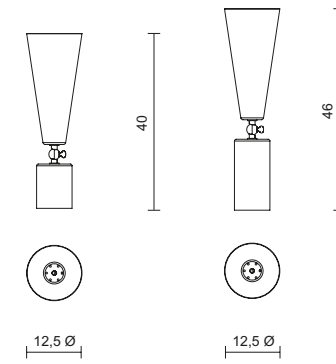

FINISHINGS





WALLIE TAVOLO

DESIGNED BY **LORENZA BOZZOLI** • 2015



DETAILS

Type: table lamp
Materials: marble / brass / steel
Weight: 7,00 kg
Insulation: class II / IP20
Bulbs: 2xLED max 3W G9 110-220V

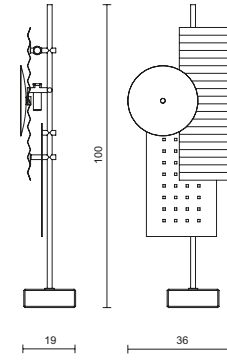

FINISHINGS



TWA300-0924
Marquinia Marble
Brass
Glossy White and Black

WALLIE PIANTANA

DESIGNED BY **LORENZA BOZZOLI** • 2015



DETAILS

Type: floor lamp
 Materials: brass / aluminum / iron
 Weight: 8,50 Kg
 Insulation: class II / IP20
 Bulbs: 1xLED max 20W E27-220V / E26-110V

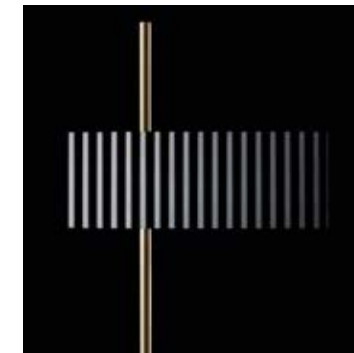
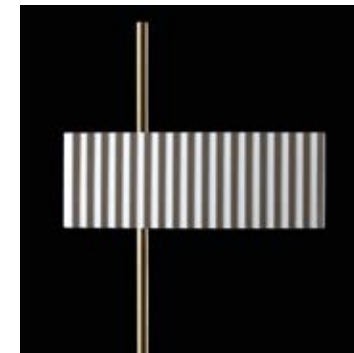
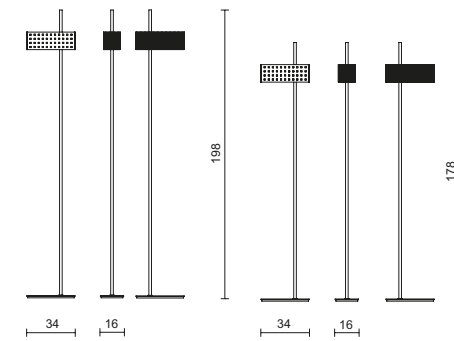

FINISHINGS



TWA400-0923
h178cm
Brass
Glossy White



TWA400-0924
h178cm
Brass
Glossy Black



TWA400-0123
h178cm
Chrome
Glossy White



TWA400-0124
h178cm
Chrome
Glossy Black



TWA410-0923
h198cm
Brass
Glossy White



TWA410-0924
h198cm
Brass
Glossy Black



TWA410-0123
h198cm
Chrome
Glossy White



TWA410-0124
h198cm
Chrome
Glossy Black

WALLIE SCULTURA

DESIGNED BY **LORENZA BOZZOLI** • 2014



DETAILS

Type: wall lamp
Materials: brass / steel
Weight: 23,00 kg
Insulation: class I / IP20
Bulbs: 5xLED max 3W G9 110-220V

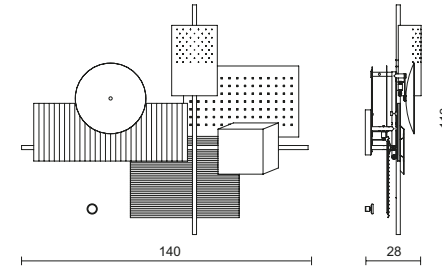

FINISHINGS

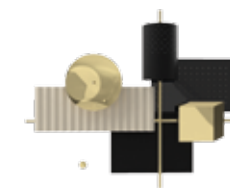

TWA200-0923
Brass
Textured and Glossy Black
Glossy White

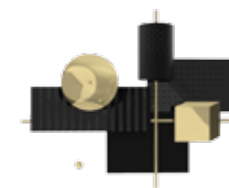

TWA200-0924
Brass
Textured and Glossy Black



WALLIE APPLIQUE

DESIGNED BY **LORENZA BOZZOLI** • 2015



DETAILS

Type: wall lamp
Materials: brass / steel
Weight: 3,50 kg
Insulation: class I / IP20
Bulbs: 2xLED max 3W G9 110-220V

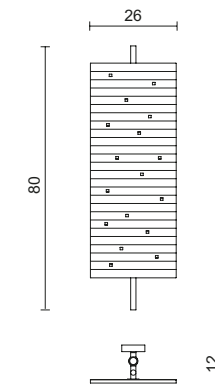

FINISHINGS



TWA210-0923
Brass
Glossy White



TWA210-0924
Brass
Glossy Black



WALLIE CHANDELIER

DESIGNED BY **LORENZA BOZZOLI** • 2015



DETAILS

Type: ceiling lamp
Materials: brass / aluminum / steel
Weight: 13,00 kg
Insulation: class I / IP20
Bulbs: 1xLED max 8W E27-220V / E26-110V
3xLED max 3W G9 110-220V

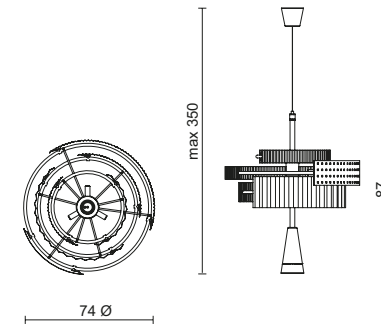

FINISHINGS



TWA100-0900
Brass
Glossy White
Glossy Black





LIVING



ANGOLO

DESIGNED BY CORRADO CORRADI DELL'ACQUA • 1963



DETAILS

Type: armchair / pouf
Materials: wood / foam / velvet
Weight: 16,00 / 13,00 / 12,00 kg

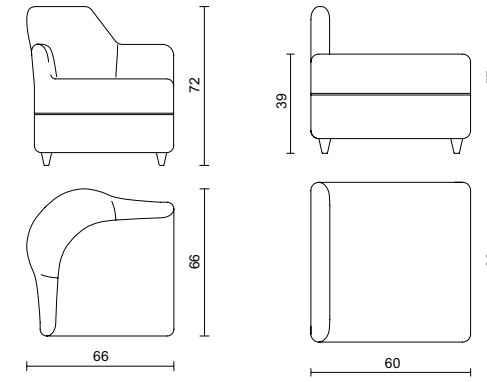

FINISHINGS



TPA600
Armchair



TPA610
Pouf with backrest



TPA620
Pouf



UPHOLSTERY
Velvet
(color of choice)

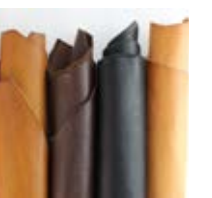

UPHOLSTERY
Leather
(color of choice)



LIDO

DESIGNED BY **IGNAZIO GARDELLA** • 1965



DETAILS

Type: armchair / sofa
Materials: wood / foam / velvet or leather
Weight: 19,00 / 25,00 kg

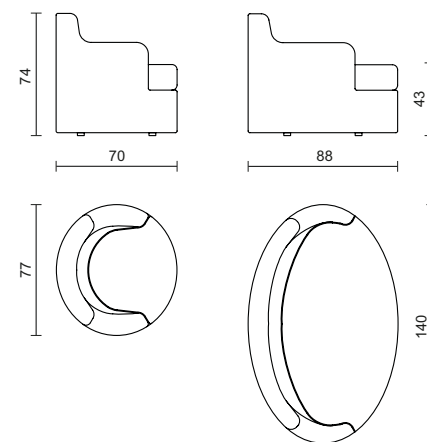

FINISHINGS



TL1600
Armchair



TL1601
Sofa



UPHOLSTERY
Velvet
(color of choice)



UPHOLSTERY
Leather
(color of choice)



TAVOLINO MONTECARLO

DESIGNED BY **CORRADO CORRADI DELL'ACQUA** • 1959



DETAILS

Type: coffee table
Materials: brass / glass
Weight: 7,00 / 10,00 / 9,00 / 14,00 Kg

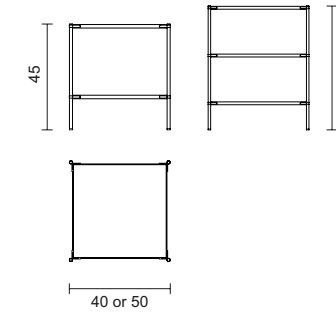

FINISHINGS



TMO600-0909
2 shelves
40x40cm
Brass



TMO600-0101
2 shelves
40x40cm
Chrome



TMO610-0909
2 shelves
50x50cm
Brass



TMO610-0101
2 shelves
50x50cm
Chrome



TMO601-0909
3 shelves
40x40cm
Brass



TMO601-0101
3 shelves
40x40cm
Chrome



TMO611-0909
3 shelves
50x50cm
Brass



TMO611-0101
3 shelves
50x50cm
Chrome

TAVOLO PIEDI REGOLABILI

DESIGNED BY **IGNAZIO GARDELLA** • 1951 / 2018



DETAILS

Type: table
Materials: wood / iron / brass

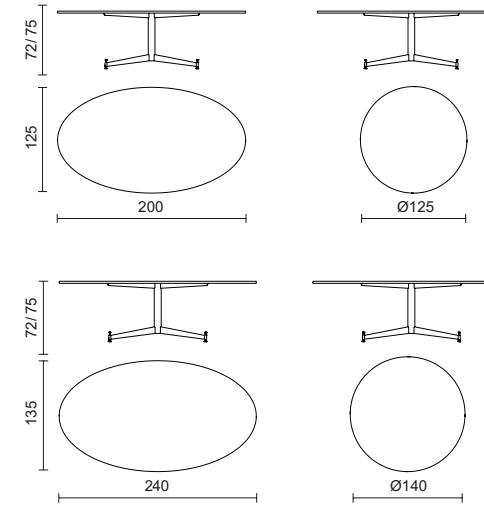

ROUND VERSION - 2018



VARIANTS

TOP SHAPE



round Ø125 cm



round Ø140 cm



oval 200x125 cm



oval 240x135 cm

TOP PROFILE

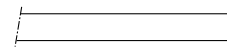
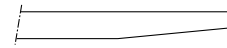
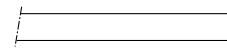
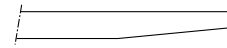
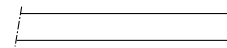
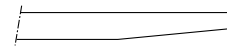
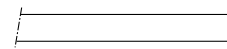

FEET FINISHING

TPR600-0935 - Brass feet
TPR600-0135 - Chrome feet

TPR610-0935 - Brass feet
TPR610-0135 - Chrome feet

TPR601-0935 - Brass feet
TPR601-0135 - Chrome feet

TPR611-0935 - Brass feet
TPR611-0135 - Chrome feet

TPR602-0935 - Brass feet
TPR602-0135 - Chrome feet

TPR612-0935 - Brass feet
TPR612-0135 - Chrome feet

TPR603-0935 - Brass feet
TPR603-0135 - Chrome feet

TPR613-0935 - Brass feet
TPR613-0135 - Chrome feet

TOP FINISHINGS



VENEER
Walnut
(Satin or Glossy)

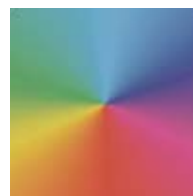

LACQUERED
Color of choice
(Matte or Glossy)



POLTRONA TRECENTOSESANTA

DESIGNED BY **EUGENIO GERLI** • 1958



DETAILS

Type: armchair
Materials: wood / foam / velvet or leather
Weight: 9,00 kg

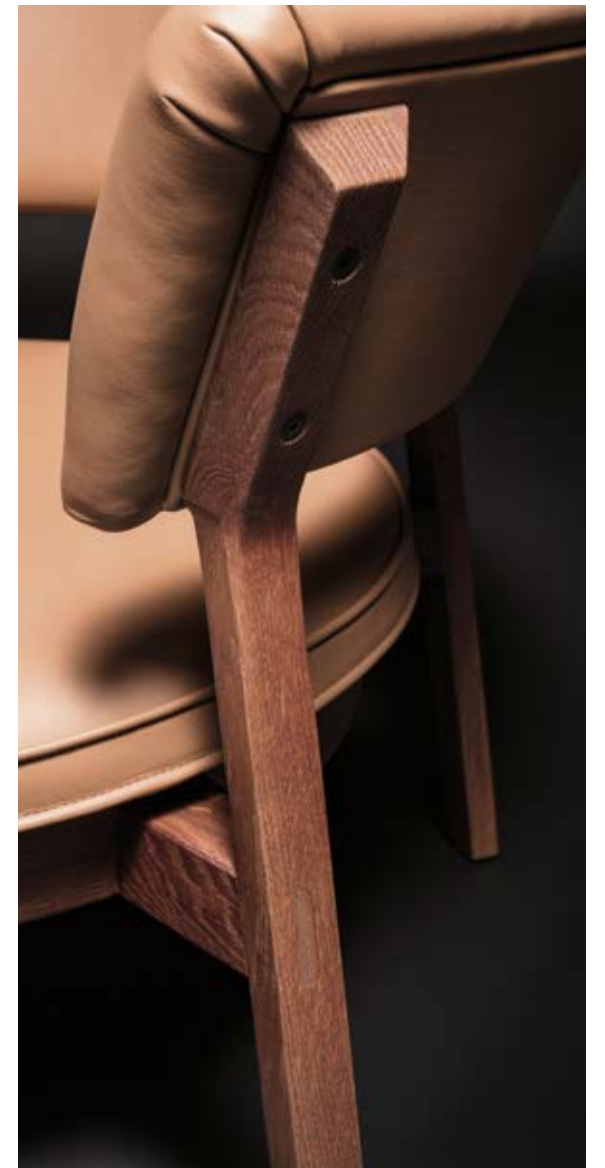
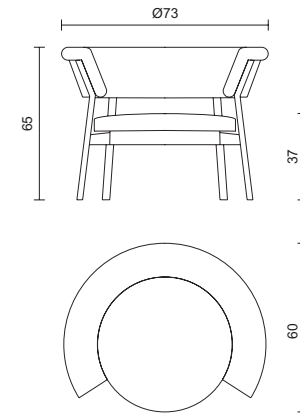

FINISHINGS

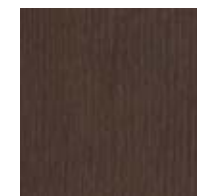

BODY
Brown Oak Wood



BODY
Black Oak Wood



UPHOLSTERY
Velvet
(color of choice)

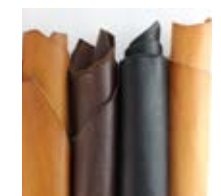

UPHOLSTERY
Leather
(color of choice)



PESTELLO

DESIGNED BY **CORRADO CORRADI DELL'ACQUA** • 1964



DETAILS

Type: ashtray
Materials: marble / brass
Weight: 4,00 kg

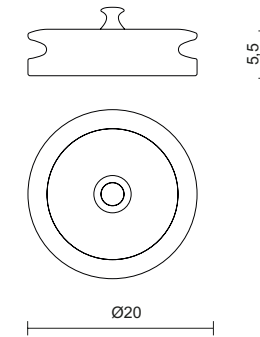

FINISHINGS



TCC980-1511
Sivec Marble
Brass

CERAMICS

DESIGNED BY **CORRADO CORRADI DELL'ACQUA** • 1960



CERAMICS

DESIGNED BY **CORRADO CORRADI DELL'ACQUA** • 1960





VASES



TCC942-3132
Ampolla Alta
Platinum
27x27x40cm



TCC942-3232
Ampolla Alta
Blue
27x27x40cm



TCC940-3132
Ampolla Bassa
Platinum
27x27x22cm



TCC940-3232
Ampolla Bassa
Blue
27x27x22cm



TCC948-3132
Ampollina
Platinum
27x27x40cm



TCC948-3232
Ampollina
Blue
27x27x40cm



TCC920-3132
4-vases set
Platinum
17x17x36cm



TCC920-3232
4-vases set
Blue
17x17x36cm



TCC946-3132
Platinum
32x32x27cm



TCC946-3231
Platinum - Blue
32x32x27cm



TCC932-3231
Platinum - Blue
22x22x12cm



CREDITS

Concept & Styling:

Alessandro Pasinelli Studio

Graphic Design:

Unidea

Photo:

Antonio Maniscalco, Tiziano Sartorio

Post Producer:

Claudia Zorzi - ZoneLab

Printed by:

Tipografia Testori Luigi & C.

Special Thanks:

Studio Gardella, Gio Ponti Archives, Lorenza Bozzoli Design

Tutti i prodotti con le relative specifiche e informazioni possono essere modificati senza preavviso dall'azienda, per migliorarne l'affidabilità, la funzionalità, il design o altro. Le fotografie e le informazioni contenute sul nostro sito internet e sui cataloghi non hanno nessun valore contrattuale. Tutte le misure dei prodotti sono espresse in cm.

All products, specifications and data could be subject to change without notice to improve reliability, function, design or otherwise. Pictures and informations present on the website and catalogues don't have any contractual value. All product dimensions are in cm.



All products are according to the EC directives

All right reserved ©2019 TATO

No text, layout or pictures may be used or reproduced for commercial purposes by third parties, including dealers, retailers, internet shops and other, without prior approval by Tato



spencer Interiors vancouver bc canada > www.spencerinteriors.com

tatoitalia.com