



Parts Included

Quantity	Item Description	Part#
2	IFP Smooth Body Shock	DK-811885R-A1200

Please check that all items are present before installation. If for any reason, there is an item or items missing send an email to sales@dirtking.com with proof of purchase and a picture of parts received.



Before installing, read all instructions. Only certified mechanics should install Dirt King products. Mandatory wheel alignment and ADAS calibration at certified facilities are required after suspension modifications. Failure to do so can lead to handling problems and safety risks. Dirt King is not responsible for damages from improper installation or misuse. Adhere to your vehicle manufacturer's recommendations. For more information, visit <https://dirtking.com/pages/disclaimer>

Step 1: Disassembly

Start by raising the vehicle and placing jack stands under the frame rails. Lower the axle to release tension off the suspension. Remove lower shock absorber mounting hardware (**Image 1**). Remove upper shock absorber mounting hardware (**Image 2**).

Image 1

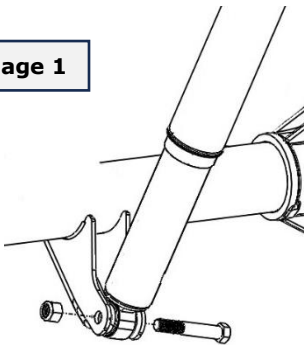
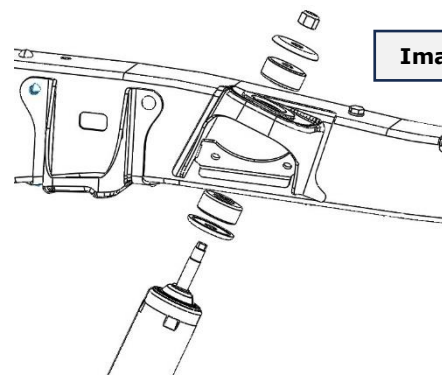

Image 2



Step 2: Assembly

Install the Dirt King shock to upper frame mount (**Image 3** ensure the shock is centered in the mount and torque hardware to **18ft lbs.** Install lower shock hardware and torque to **43ft lbs.** (**Image 4**).

Image 3

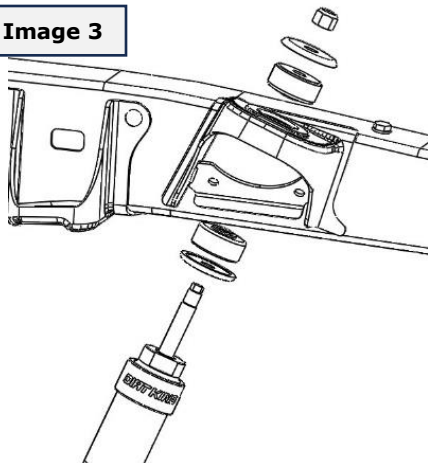
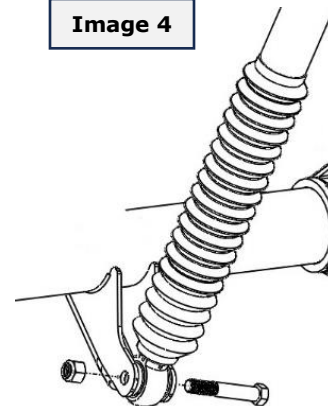

Image 4



Step 3: Inspect your work.

Thoroughly go over your work then repeat steps for opposite side of vehicle. Reinstall wheels and torque lug nuts to your wheel manufacturers specs.

For warnings and disclaimers visit <https://dirtking.com/pages/disclaimer>.