



Parts Included

Quantity	Item Description	Part#
2	Coil-Over Shock	DK-636985F-A1200
1	Spanner Wrench	DK-SW001
1	Allen Key	N/A

Please check that all items are present before installation. If for any reason, there is an item or items missing send an email to sales@dirtking.com with proof of purchase and a picture of parts received.



Before installing, read all instructions. Only certified mechanics should install Dirt King products. Mandatory wheel alignment and ADAS calibration at certified facilities are required after suspension modifications. Failure to do so can lead to handling problems and safety risks. Dirt King is not responsible for damages from improper installation or misuse. Adhere to your vehicle manufacturer's recommendations. For more information, visit <https://dirtking.com/pages/disclaimer>

Step 1: Disassembly

Start by raising the vehicle and placing jack stands under the frame rails. Next remove the front wheels. Disconnect the brake hose bracket, wheel speed sensor, and brake wear sensor to prevent damage during shock removal. Remove the sway bar link nut from lower control arm (**Image 1**). Loosen the upper control arm ball joint nut. Strike the side of the knuckle to loosen the ball joint taper (**Image 2**). Rotate the upper control arm upward. **Note:** Aftermarket upper control arms are required with these shocks. Remove the upper and lower shock bolts. Now remove the shock from the vehicle.

Image 1

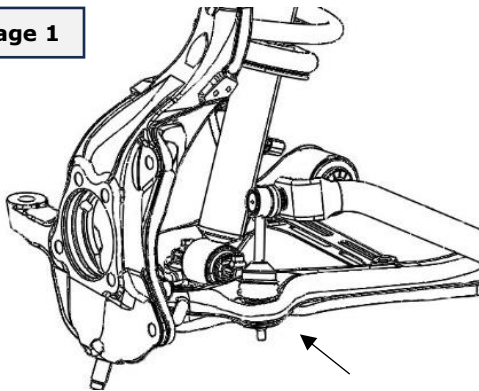
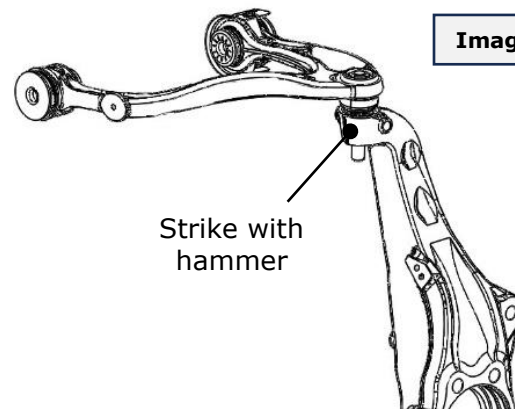

Image 2



Step 2: Assembly

Install the Dirt King shock by lowering the bottom mount into position (**Image 3**). Apply blue thread locker and torque lower shock bolts to 50ft lbs. Align the top of shock to the coil bucket (**Image 4**). Apply blue thread locker to the top shock mounting bolts and torque to 35ft lbs. Insert the upper arm ball joint into the knuckle and torque to manufacturer's specs. Lastly install the sway bar link using the OE hardware and torque to 74ft lbs.

Image 3

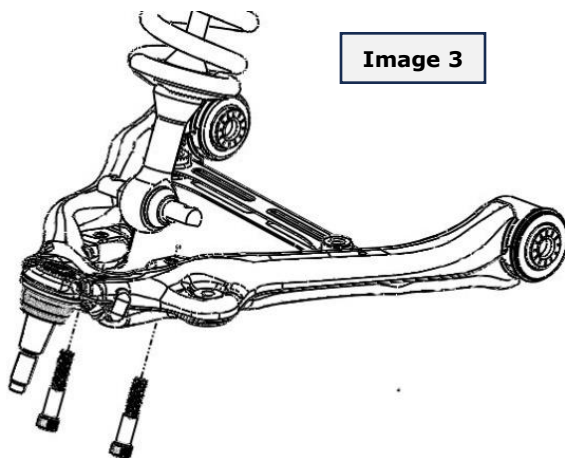

Image 4

