



SDHQ Motorsports
190 S McQueen Rd
Ste 109 Gilbert, AZ 85233
www.SDHQoffroad.com

Product Packing List

Product: *SDHQ-70-1130-G4*

Description: Gen 4 Silverado/Sierra Switch Pros 9100
Keypad Mount

Fitment: 2019-2021 1500 (excluding 1500 LD)
2022 1500 Limited
2020-2023 2500/3500

_____ (1) SDHQ Switch Pros 9100 Keypad Mount
_____ (1) SDHQ Drilling Template

SDHQ-70-1130-G4-A
SDHQ-70-1130-G4-B

Inspected and Packaged By: _____ Date: _____

For questions or help with the installation, please email help@sdhqoffroad.com
Store front hours: Mon. – Fri. 8:00am – 5:30pm and Sat. 9:00am – 2:00pm Arizona Time.

For questions or help with the installation, please email help@sdhqoffroad.com
Store front hours: Mon. – Fri. 8:00am – 5:30pm and Sat. 9:00am – 2:00pm Arizona Time.



SDHQ Motorsports
190 S McQueen Rd
Ste 109 Gilbert, AZ 85233
www.SDHQoffroad.com

INSTALLATION INSTRUCTIONS

Product: SDHQ-70-1130-G4

Description: SDHQ Built Switch Pros 9100 Keypad Mount



Parts List	Hardware List	Required Tools
(1) SDHQ SP-9100 Keypad Mount SDHQ-70-1130-G4-A (1) SDHQ Dash Drilling Template SDHQ-70-1130-G4-B		Plastic Panel Remover Drill 5/64" Drill Bit 3/4" Step Drill Bit or Hole Saw T-15 Torx Bit 7mm, 10mm, 9/32" Socket Ratchet
Tech Notes		
Approx. Install Time: 1 Hour (not including wiring)		

***READ ALL INSTRUCTIONS THOROUGHLY FROM START TO FINISH BEFORE BEGINNING INSTALLATION! ***

For questions or help with the installation, please email help@sdhqoffroad.com
Store front hours: Mon. – Fri. 8:00am – 5:30pm and Sat. 9:00am – 2:00pm Arizona Time.

CAD Rendering/Exploded Views



Drilling Template

Use this Top Edge to Locate the Drilling Template

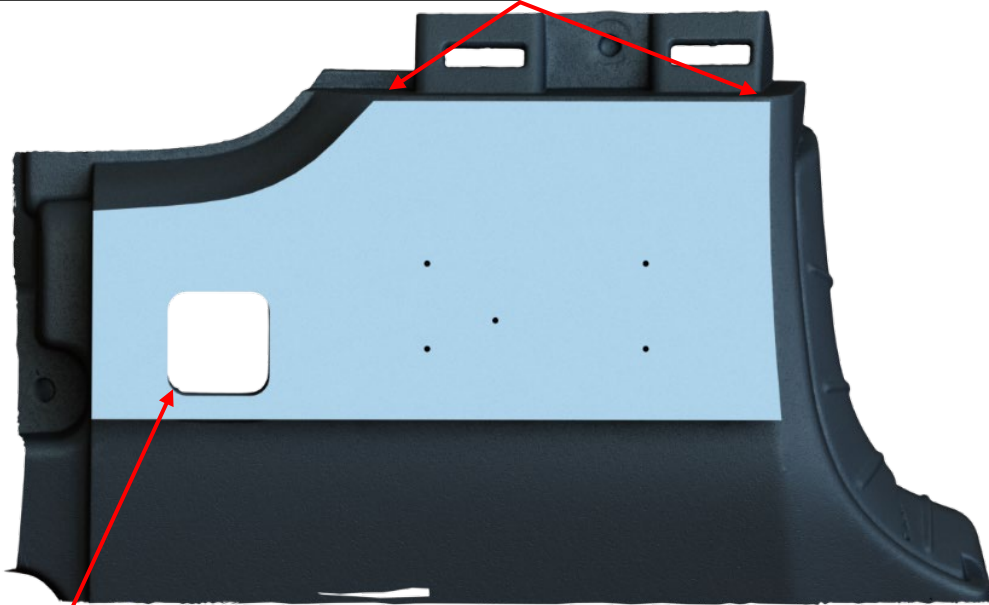

Use this Square Switch to Locate the Drilling Template

Installation Instructions:

1. Unbox all parts and familiarize yourself with them.
2. Remove the Fuse Cover from the Driver side of the Dashboard and remove the Instrument Panel Hood by using a flat-bladed plastic trim tool, there are 6 retaining clips.

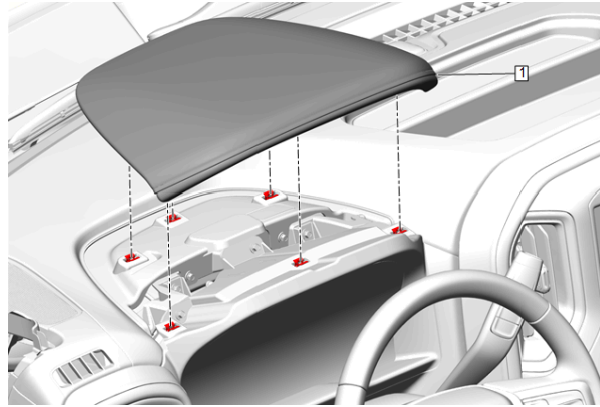

3. Remove the Left Side Instrument Panel Trim Pad, using a T-15 Torx bit remove the two screws and use a plastic trim tool to remove the panel. Disconnect any wiring connectors on the back of the panel.

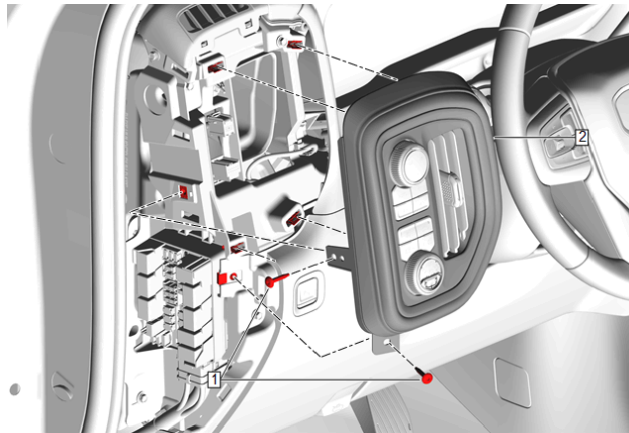

4. Remove the Radio Bezel by using a pry tool on the bottom corner and carefully removing the bezel. Remove the piece below the Radio Unit to access the lower screws for the Radio Unit.

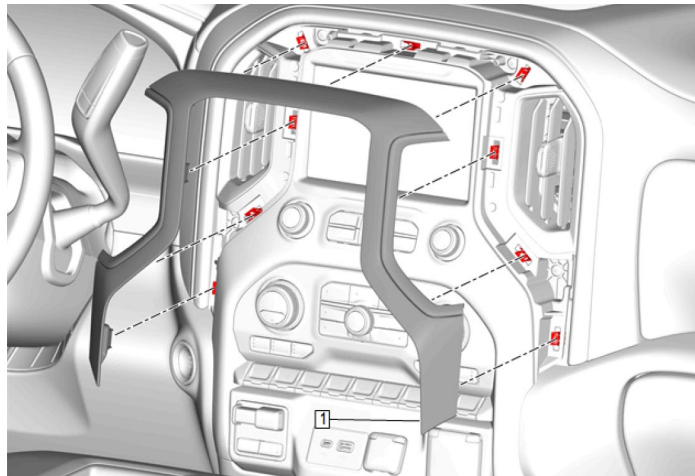

5. Remove the (6) T15 Torx Screws to Remove the Radio Unit there will be several connectors on the back of the Radio Unit be careful when disconnecting these.

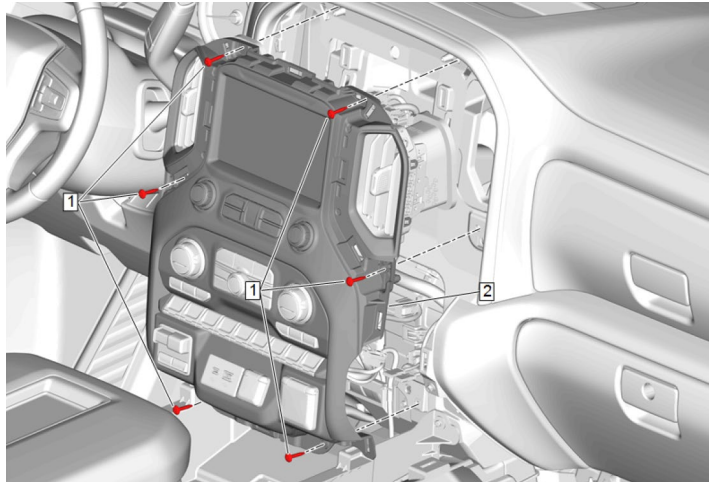

6. Loosen the Front Dash Trim Panel, start from the driver side of the panel and full remove should not be necessary.

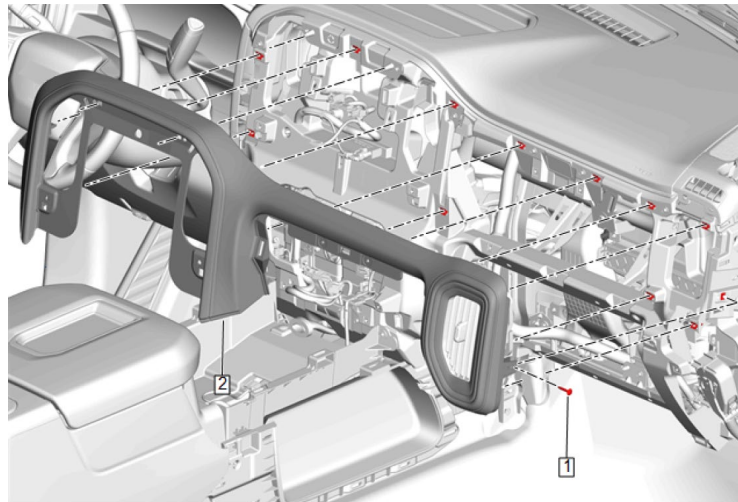

7. Remove the Instrument Panel Cluster Trim, remove the (3) 7mm screws at the top of the panel. Use a plastic trim tool to release the clips, this part can be attached to the top part of the steering column cover. If attached remove the top part of the steering column cover.

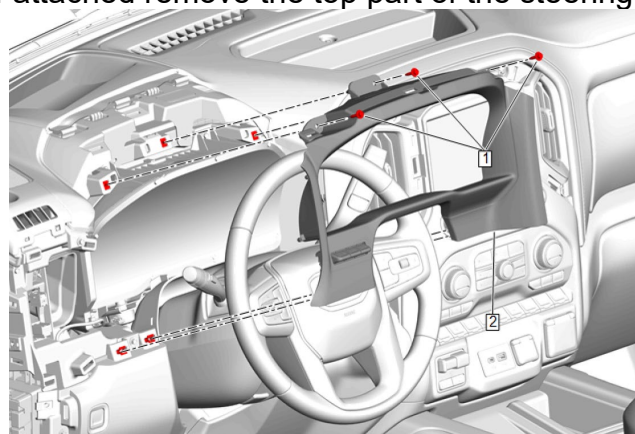

8. Remove the Instrument Panel Knee Bolster by remove the hood release, removing the (5) 10mm bolts and pulling to release clips, disconnect any electrical connections.

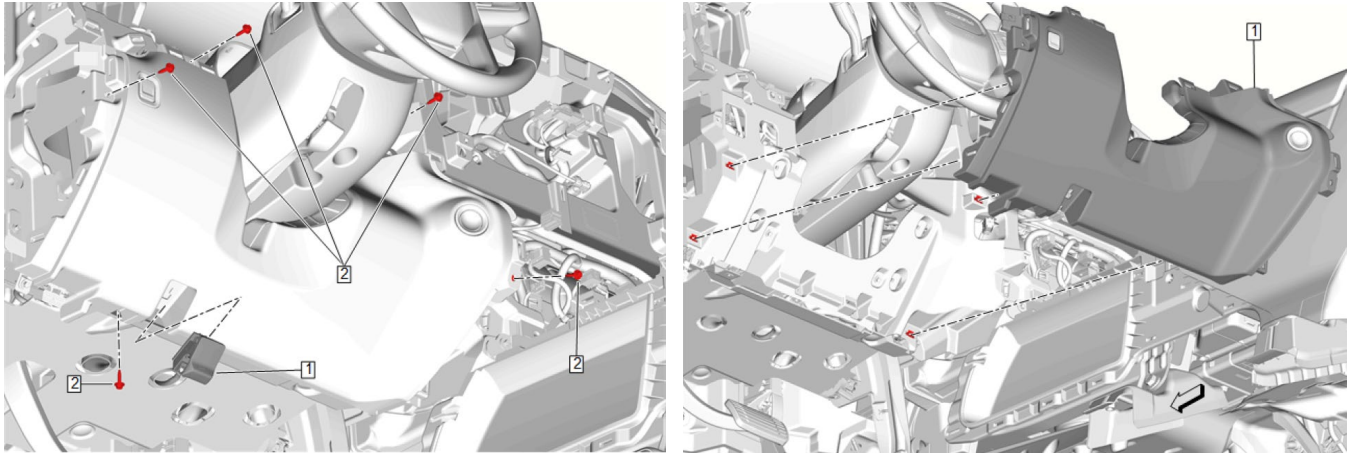

9. Place the Template on the panel as shown. Drill holes using a 5/64" drill bit for the (4) corner holes red circles and (1) 3/4" hole for the wiring connector blue circle.

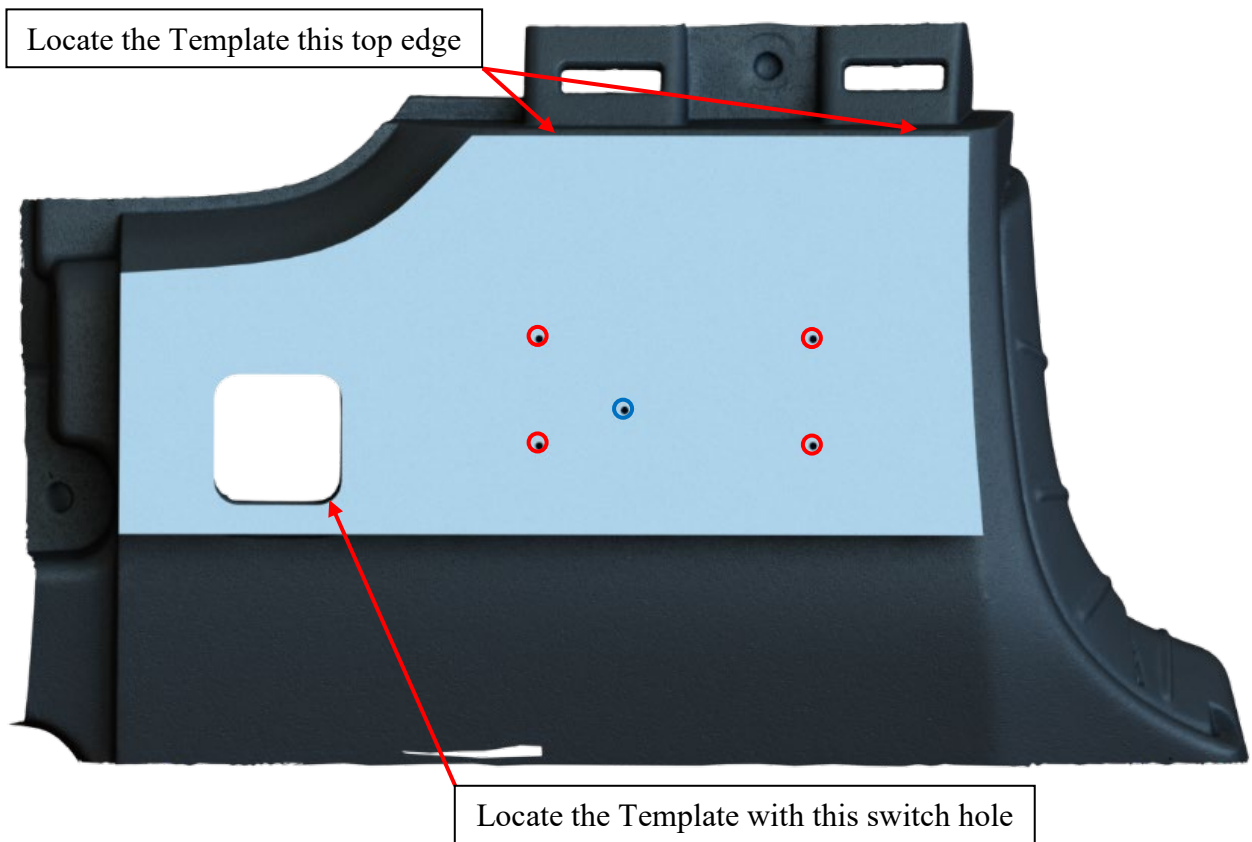

- 10.** Place keypad into the provided mount and place mount onto the dash panel, use the hardware provided by Switch Pros to attach the mount to the dash panel. Pause to run the wiring for the keypad while interior panels are removed.

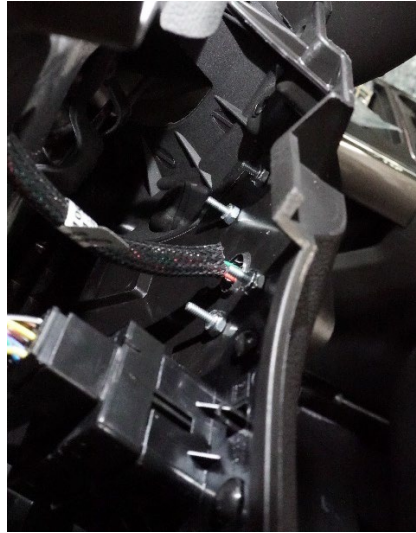

- 11.** Reinstall the Instrument Panel Knee Bolster, attach the electrical connectors and push panel into place until clips snap in. Reinstall the Hood Release if removed and the (5) 10mm bolts.

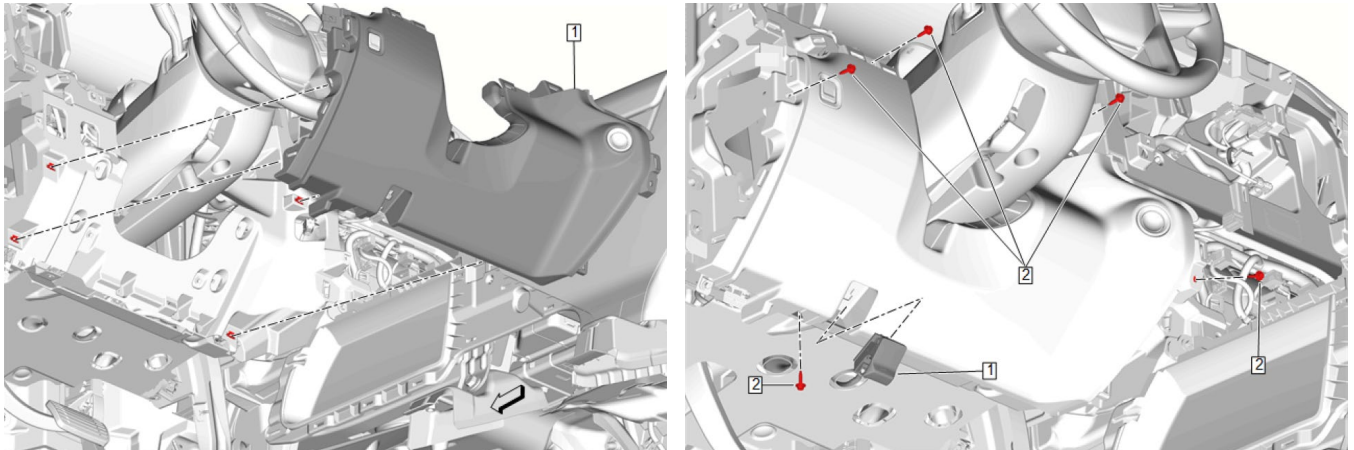

- 12.** Reinstall the Instrument Cluster Trim, install the (3) 7mm screws at the top of the panel. Reinstall the top panel of the steering column cover if needed.

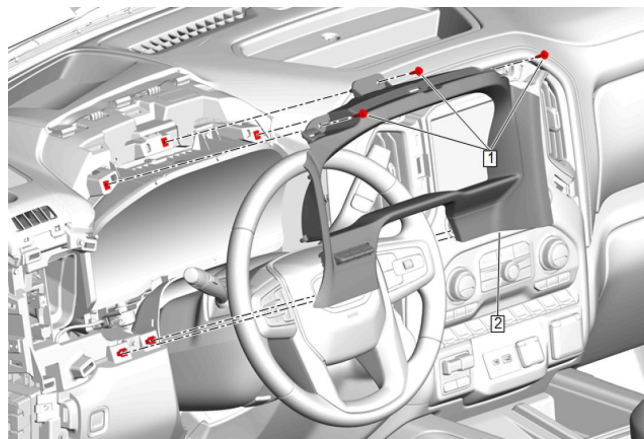

For questions or help with the installation, please email help@sdhqoffroad.com
Store front hours: Mon. – Fri. 8:00am – 5:30pm and Sat. 9:00am – 2:00pm Arizona Time.

13. Reinstall the Front Dash Trim Panel, push on the panel until the clips snap in. Reinstall the Radio Unit by reattaching the electrical connections and replacing the (6) T15 Torx Screws.

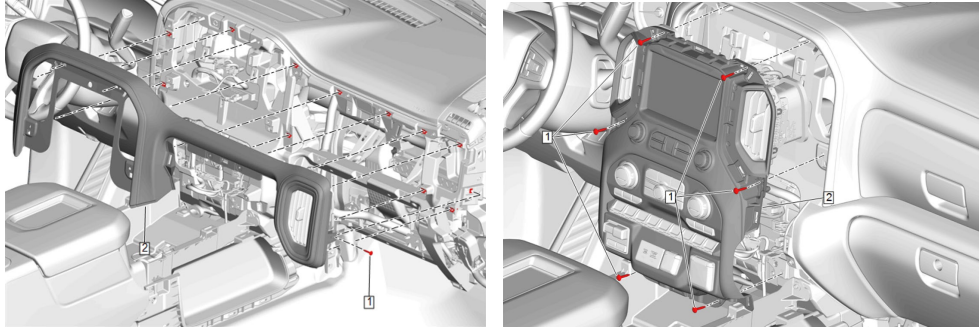

14. Reinstall the Radio Bezel by pushing on the panel until the clips snap in. Reinstall the piece that is placed below the Radio Unit by pushing on it until the clips snap in.

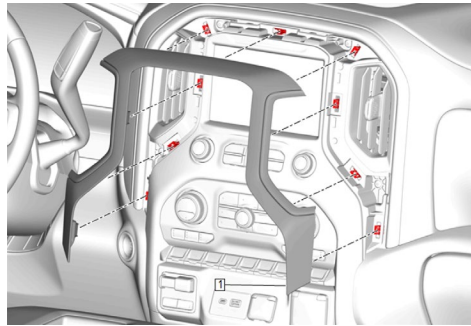

15. Reinstall the Left Side Instrument Panel Trim Pad, using a T-15 Torx install the two screws. Reconnect any wiring connectors on the back of the panel.

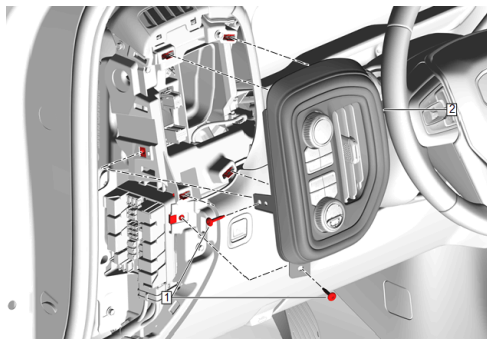

16. Reinstall the Fuse Cover from the Driver side of the Dashboard and the Instrument Panel Hood by pushing on the panels until the clips snap in.

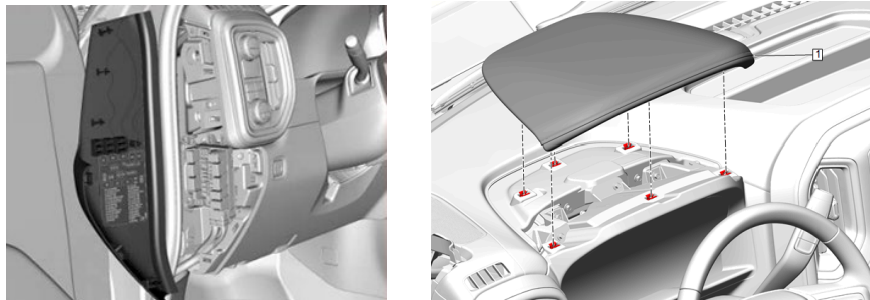

17. Enjoy your new SDHQ Built 9100 Keypad Mount for your GM Truck.

For questions or help with the installation, please email help@sdhqoffroad.com
Store front hours: Mon. – Fri. 8:00am – 5:30pm and Sat. 9:00am – 2:00pm Arizona Time.

Double check all hardware is installed correctly and tight

Re-torque ALL bolts after 100 miles



190 S McQueen Rd
Ste 109 Gilbert, AZ 85233
www.sdhqoffroad.com

Follow us on:



Facebook



Instagram

For questions or help with the installation, please email help@sdhqoffroad.com
Store front hours: Mon. – Fri. 8:00am – 5:30pm and Sat. 9:00am – 2:00pm Arizona Time.