



SDHQ Motorsports
190 S McQueen Rd
Ste 109 Gilbert, AZ 85233
Phone: 480-633-2929

Product Packing List

Product: SDHQ-55-1540-G2

Description: 2005-2015 Tacoma Short Bed Rock Sliders

- | | |
|---------------------------------------------|--------------------|
| _____ (1) Driver Side Slider | SDHQ-55-1540-G2-A |
| _____ (1) Passenger Side Slider | SDHQ-55-1540-G2-B |
| _____ (2) Front Inner Single Brackets | SDHQ-54-1540-G5-C |
| _____ (1) Gas Tank Upper Bracket | SDHQ-55-1540-G3-D |
| _____ (2) Front Inner Double Brackets | SDHQ-54-1540-G5-D |
| _____ (2) Upper Brackets | SDHQ-50-1540-P1 |
| _____ (3) Trimmed Upper Brackets | SDHQ-50-1540-P2 |
| _____ (6) Lower Brackets | SDHQ-50-1540-P3 |
| _____ (1) Hardware Package | SDHQ-55-1540-G2-HP |
| _____ (18) 3/8" - 16 x 1 1/4" Grade 8 Bolts | |
| _____ (18) 3/8" Grade 8 Flat Washers | |
| _____ (18) 3/8" Grade 8 Lock Washers | |
| _____ (6) 7/16" - 14 x 1 1/4" Grade 8 Bolts | |
| _____ (6) 7/16" Grade 8 Flat Washers | |
| _____ (6) 7/16" Grade 8 Lock Washers | |
| _____ (1) Loctite Packet | |

Inspected and Packaged By: _____ Date: _____

**For questions or help with the installation, please call SDHQ Offroad @ 480-633-2929
Mon.–Fri. 8:00am–5:30pm and Sat. 8:00am–3:30pm Arizona Time. www.sdhqoffroad.com**



SDHQ Motorsports
 190 S McQueen Rd
 Ste 109 Gilbert, AZ 85233
 Phone: 480-633-2929

INSTALLATION INSTRUCTIONS

Product: SDHQ-55-1540-G2

Description: 2005-2015 Tacoma Short Bed Rock Sliders



<u>Parts List</u>	<u>Hardware List</u>	<u>Required Tools</u>
(1) Driver Side Slider (1) Passenger Side Slider (2) Front Inner Single Bracket (1) Gas Tank Bracket (2) Front Inner Double Bracket (2) Upper Bracket (3) Trimmed Upper Bracket (6) Lower Bracket (2) Front Inner Single Bracket (1) Hardware Package	(18) 3/8"-16 x 1 1/4" bolts (18) 3/8" flat washers (18) 3/8" lock washers (6) 7/16"-14 x 1 1/4" bolts (6) 7/16" flat washers (6) 7/16" lock washers (1) Loctite Packet	1/2" socket/wrench 9/16" open/box combination wrench 5/8" socket/wrench 8mm socket/wrench 10mm wrench/socket 12mm socket/wrench 14mm socket/wrench

Tech Notes

The driver's side slider can be tricky to bolt up next to the gas tank. Follow instructions carefully in order to save time and frustration. It is recommended the install is performed by at least 2 qualified technicians. For strongest and best fit, use a jack under each mount when tightening. Use red Loctite on all hardware.

Sliders fit Double Cab Short Bed and Access Cab Long Bed trucks

Approx install time = 2 hours

*****READ ALL INSTRUCTIONS THOROUGHLY FROM START TO FINISH BEFORE BEGINNING INSTALLATION!*****

For questions or help with the installation, please call SDHQ Offroad @ 480-633-2929
 Mon.-Fri. 8:00am-5:30pm and Sat. 8:00am-3:30pm Arizona Time. www.sdhqoffroad.com



Front Inner Single Bracket
SDHQ-54-1540-G5-C

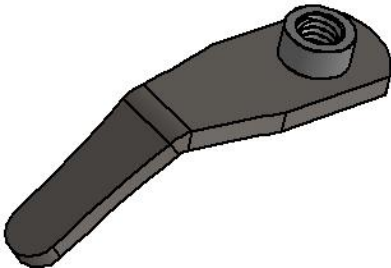

Gas Tank Upper Bracket
SDHQ-55-1540-G3-D

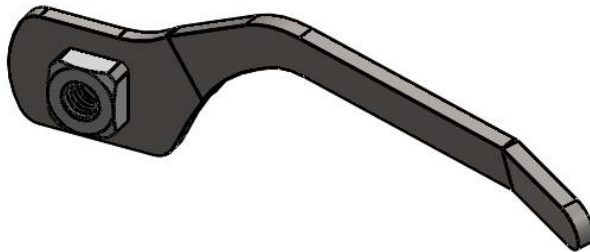

Front Inner Double Bracket
SDHQ-54-1540-G5-D



Upper Bracket
SDHQ-50-1540-P1



Trimmed Upper Bracket
SDHQ-50-1540-P2

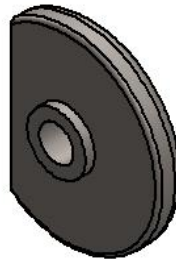

Lower Bracket
SDHQ-50-1540-P3

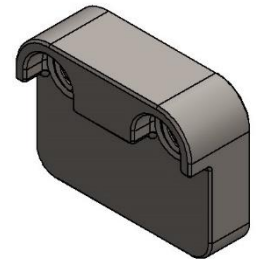

Installation Instructions:

- 1. Preparing your Tacoma.** If your Tacoma is equipped with a gas tank skid plate, remove the (4) 12mm bolts holding it on, remove, and set aside. It is necessary to lower your gas tank 2 ½", enough to reach the rear inner brackets. Support your gas tank with a jack, remove the (2) 14mm tank strap bolts and lower your tank as much as possible without stretching or kinking any of the lines.



- 2.** The Driver side frame has brake hard lines running to the rear axle, to ease install, pinch the outside of the retaining clip and push it through the frame so the hard lines can move without being damaged. Pictured below



- 3.** Starting with the driver's side, insert the Front Inner Double Bracket and the Front Inner Single Bracket into the front body mount. The Front Inner Double Bracket locates on the lower 2 open holes with the nuts facing up, and the flat edge going away from the body mount. The Front Inner Single Bracket locates in the middle open hole with the nut facing up. Driver's side is shown below.

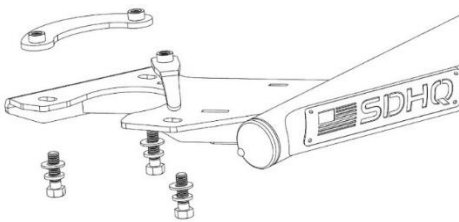

- 4. Installing the Sliders.** For installing the sliders, lift into position and install (1) Upper Bracket and (1) Trimmed Upper Bracket using 7/16" bolts and washers. The Trimmed Upper Bracket installs in the rear position. This will hold the sliders up while you line up and install the rest of the hardware. Next, install (2) Lower Brackets with the 3/8" bolts and washers. Leave all hardware loose until every bolt is started. Use red Loctite on all hardware.

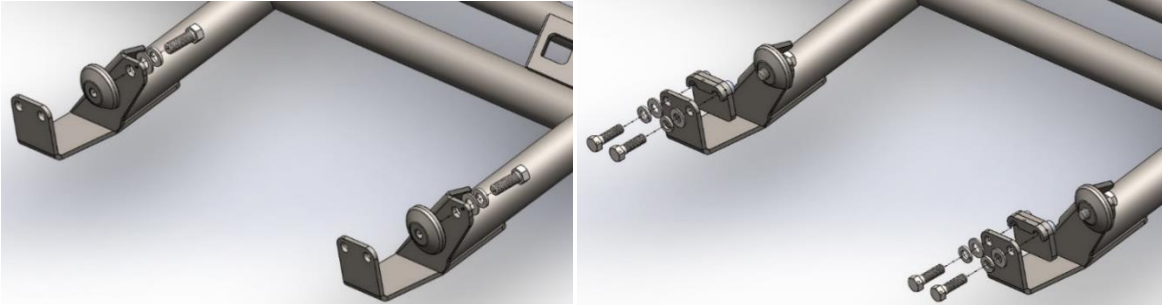

- 5. Align and start the (3) 3/8" bolts in the Front Inner Single Bracket and Front Inner Double Bracket and leave slightly loose.**



6. While moving the tank as far out of the way as possible, insert the Upper Gas Tank Mount into the inside of the frame and thread the 7/16" bolt and washers in from the outside. The Upper Gas Tank Mount should fit behind the brake and gas lines, but it is a tight fit. Make sure your lines are not positioned in a way that they can chafe on any bracket. Now install the inner rear bracket with the (2) 3/8" bolts and washers. It may be helpful to lower the spare tire and insert the bracket from the back side.

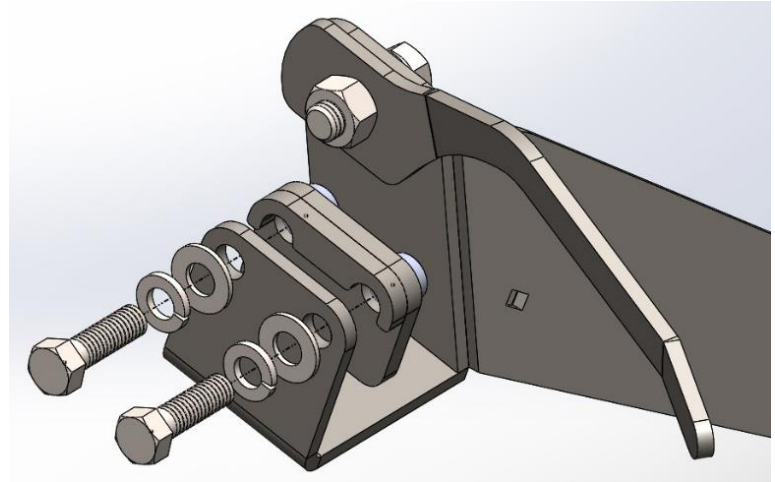
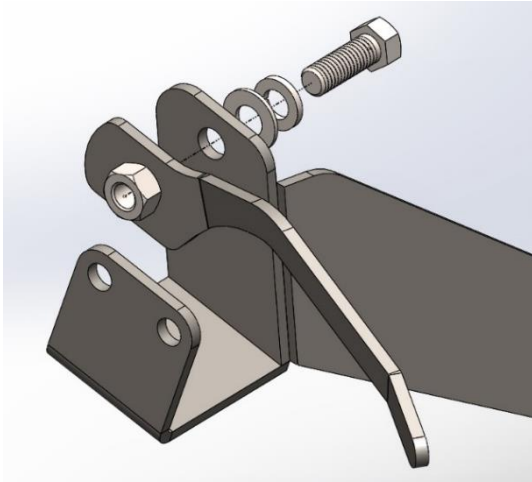

7. Once all the hardware is started, you can tighten everything. It is recommended to use a jack under each mount when tightening. Tighten the outer 7/16" bolts first, then tighten the inner 3/8" bolts. Once the sliders are tight, reposition and reinstall your gas tank and skid plate.
8. For the passenger side, follow the same steps as the driver's side, except there is no gas tank in the way.
9. Consistent with the driver's side, get all of the hardware in and started before tightening anything. Once everything is started and snug, tighten the 7/16" bolts first, then tighten all of the 3/8" bolts.
10. Enjoy your SDHQ Built Rock Sliders for your 2005-2015 Toyota Tacoma!



For questions or help with the installation, please call SDHQ Offroad @ 480-633-2929
Mon.-Fri. 8:00am-5:30pm and Sat. 8:00am-3:30pm Arizona Time. www.sdhqoffroad.com

*****Double check all hardware is installed correctly and tight*****

*****Re-torque ALL bolts after 100 miles*****



190 S McQueen Rd
Ste 109 Gilbert, AZ 85233
Phone: 480-633-2929 | Fax: 480-633-1791
www.sdhqoffroad.com

Follow us on:



Facebook



Instagram

For questions or help with the installation, please call SDHQ Offroad @ 480-633-2929
Mon.–Fri. 8:00am–5:30pm and Sat. 8:00am–3:30pm Arizona Time. www.sdhqoffroad.com