



SDHQ Motorsports
190 S McQueen Rd
Ste 109 Gilbert, AZ 85233
Phone: 480-633-2929

Product Packing List

Product: *SDHQ-53-9212-63*

Description: '07-'21 Tundra & '08-'22 Sequoia & '08-'21
Land Cruiser/LX 570 Dual Battery Billet Power
Steering Reservoir Mount

_____ (1) SDHQ Dual Battery PS Reservoir Mount SDHQ-53-9212-63-A

Inspected and Packaged by: _____ **Date:** _____

For questions or help with the installation, please call SDHQ Offroad @ 480-633-2929
Mon.-Fri. 8:00am-5:30pm and Sat. 8:00am-3:30pm Arizona Time. www.sdhqoffroad.com



SDHQ Motorsports
190 S McQueen Rd
Ste 109 Gilbert, AZ 85233
Phone: 480-633-2929

INSTALLATION INSTRUCTIONS

Product: SDHQ-53-9212-G3

Description: '07-'21 Tundra & '08-'22 Sequoia & '08-'21 Land Cruiser/LX 570 Dual Battery Billet Power Steering Reservoir Mount



<u>Parts List</u>	<u>Hardware List</u>	<u>Required Tools</u>
(1) SDHQ Dual Battery PS Reservoir Mount SDHQ-53-9212-G3-A	N/A	10mm Socket 1/2" Socket Ratchet 1/2" Wrench 6" Extension Hand Pump Siphon Oil Catch Container Shop Rags #6 and #10 AN or adjustable Wrench
<u>Tech Notes</u>		
This kit is ONLY needed if you are purchasing a Tundra/LC Dual Battery Kit (SDHQ-53-3001-G3) and already own the Tundra/LC Billet Power Steering Reservoir Kit (SDHQ-53-9201-G3). Exercise extreme caution when working on a vehicle's power steering system. Fluids can be hot and/or pressurized. Check the reservoir fluid levels at operating temperatures after 25 – 50 miles of driving. Approx. Install Time: 1 Hour		

READ ALL INSTRUCTIONS THOROUGHLY FROM START TO FINISH BEFORE BEGINNING INSTALLATION!

For questions or help with the installation, please call SDHQ Offroad @ 480-633-2929
Mon.–Fri. 8:00am–5:30pm and Sat. 8:00am–3:30pm Arizona Time. www.sdhqoffroad.com

Installation Instructions:

1. **Removing the SDHQ Power Steering Mount.** Siphon out the power steering fluid in the reservoir. Remove the (3) 10mm bolts securing the SDHQ Power Steering Mount to the truck. Remove the 5/16" Bolt, 5/16" Washers and 5/16" Locknut securing the Billet Reservoir to the SDHQ Power Steering Mount. Remove the (2) 1/4" Socket Head Bolts, Washers and Nut Clips if you have the SDHQ Power Steering Reservoir Filter. Keep all of the hardware as it will be reused with the new mount. Remove the SDHQ Power Steering Mount from the Billet Power Steering Reservoir.
2. It is recommended to remove the SDHQ Billet Power Steering Reservoir from the vehicle. This will allow adequate space for installing the Tundra Dual Battery Tray. To do this, remove the -6 and -10 AN Fittings from the bottom of the Reservoir/Filter.

Before installing the Power Steering Reservoir, proceed to Step 8 in the Tundra Dual Battery Kit Installation Instructions (**SDHQ-53-3001-G3**) or Step 9 in the Land Cruiser Dual Battery Kit (**SDHQ-52-3001-200**). Do **NOT** replace the larger diameter power steering hose with the 24" supplied in your dual battery kit, it will not fit properly over the push lok fitting and it will leak.

3. **Installing the Power Steering Reservoir.** If you have the SDHQ Power Steering Reservoir Filter, install (2) 1/4" – 20 Nut Clips from Step 1 onto the tab on the SDHQ Dual Battery PS Reservoir Mount. Install (2) 5/16" – 20 Nut Clips from the Tundra Dual Battery Kit (**SDHQ-53-3001-G3**) onto the SDHQ Dual Battery PS Reservoir Mount as shown right.

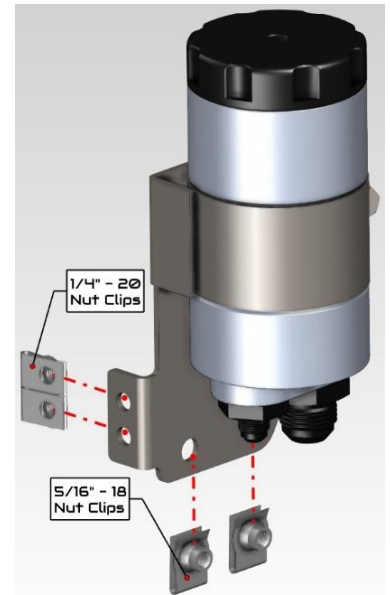

4. Install the SDHQ Dual Battery PS Reservoir Mount onto the Billet Power Steering Reservoir. Secure the SDHQ Power Steering Reservoir Filter onto the SDHQ Dual battery PS Reservoir Mount with the (2) 1/4" – 20 x 1 1/4" S.S. Socket Head Bolts and Washers if applicable. Secure the Billet Reservoir with the 5/16" Bolt, Washers and Locknut from Step 1.
5. Install the SDHQ Dual Battery Power Steering Mount onto the Dual Battery Tray using (2) 5/16" Button Head Bolts and washers from the Tundra Dual Battery Kit (**SDHQ-53-3001-G3**) or the Land Cruiser Dual Battery Kit (**SDHQ-52-3001-200**). Be sure to align the Upright Support Bracket between the Main Battery Mount and the Power Steering Mount. See Figure 4 on Page 4 of the Tundra/LC Dual Battery Kit.

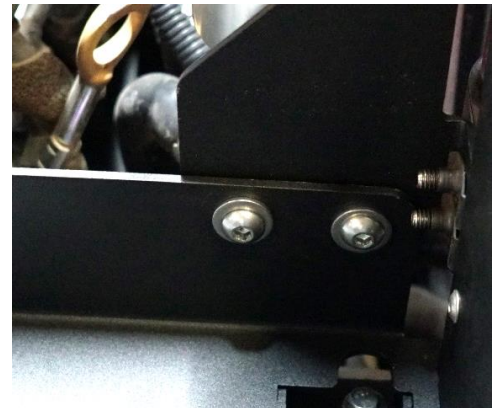

The SDHQ Dual Battery Power Steering Reservoir Kit (**SDHQ-53-9211-G3**) install is complete. Proceed to Step 17 in the Tundra Dual Battery Kit (**SDHQ-53-3001-G3**) or Step 14 in the Land Cruiser Dual Battery Kit (**SDHQ-52-3001-200**)

6. There will be some left over parts from the Tundra Dual Battery Kit (**SDHQ-53-3001-G3**) such as the 17" Power Steering Hose, (2) 1/4" – 20 x 3/4" S.S. Button Head Bolts, (4) 1/4" S.S. SAE Washers, (2) 1/4" – 20 S.S. Nylock Nuts and the SDHQ Reservoir Mount/SDHQ Reservoir to Tray Mount.

*****Double check all hardware is installed correctly and tight*****

*****Re-torque ALL bolts after 100 miles*****



190 S McQueen Rd
Ste 109 Gilbert, AZ 85233
Phone: 480-633-2929 | Fax: 480-633-1791
www.sdhqoffroad.com

Follow us on:



Facebook



Instagram

For questions or help with the installation, please call SDHQ Offroad @ 480-633-2929
Mon.–Fri. 8:00am–5:30pm and Sat. 8:00am–3:30pm Arizona Time. www.sdhqoffroad.com