



SDHQ Motorsports
190 S McQueen Rd
Ste 109 Gilbert, AZ 85233
Phone: 480-633-2929

Product Packing List

Product: SDHQ-53-3001-G3

Description: 2007-2021 Toyota Tundra & 2008-2022
Toyota Sequoia Dual Battery Tray Kit

Batteries NOT included

_____	(1) Main Battery Mount	SDHQ-53-3001-G3-A
_____	(1) Blue Sea ML-ACR Mount	SDHQ-53-3001-G3-B
_____	(1) SDHQ PS Reservoir Mount	SDHQ-53-3001-G3-C
_____	(1) PS Reservoir to Tray Mount	SDHQ-53-3001-G3-D
_____	(1) Bottom Support Doubler Bracket	SDHQ-53-3001-G3-E
_____	(1) Bottom Support Bracket	SDHQ-53-3001-G3-F
_____	(1) Upright Support Bracket	SDHQ-53-3001-G3-G
_____	(1) Bottom Rear Support Bracket	SDHQ-53-3001-G3-H
_____	(1) SDHQ Auxiliary Billet Battery Hold Down	SDHQ-50-3005-U1-A
_____	(1) Hardware Package	SDHQ-53-3001-G3-HP

Inspected and Packaged By: _____ Date: _____

For questions or help with the installation, please call SDHQ Offroad @ 480-633-2929
Mon.-Fri. 8:00am-5:30pm and Sat. 8:00am-3:30pm Arizona Time. www.sdhqoffroad.com

Included in Hardware Package SDHQ-53-3001-63-HP:

- (2) ¼" - 20 x ¼" S.S. Button Head Bolts
- (2) ¼" - 20 S.S. Nylock Nuts
- (11) ¼" S.S. SAE Washers
- (2) ¼" ID x 1 ¼" OD S.S. Fender Washers
- (7) M6 - 1.0 x 25mm S.S. Hex Head Bolts
- (5) M6 - 1.0 S.S. Serrated Flange Nuts
- (5) 5/16" - 18 x 1" S.S. Button Head Bolts
- (5) 5/16" S.S. SAE Washers
- (5) 5/16" - 18 Nut Clips
- (2) 3/8" - 16 x 9" Threaded Rods
- (2) 3/8" - 16 S.S. Serrated Flange Nuts
- (2) 3/8" S.S. with Rubber Washers
- (1) Quart of Power Steering Fluid
- (1) 24" - 5/8" Power Steering Hose with 90° Brass Fitting
- (1) 17" - 3/8" Power Steering Hose
- (5) Edge Zip Ties
- (1) 3" of Door Edge Trim
- (1) Tube of Anti-Seize



For questions or help with the installation, please call SDHQ Offroad @ 480-633-2929
Mon.-Fri. 8:00am-5:30pm and Sat. 8:00am-3:30pm Arizona Time. www.sdhqoffroad.com



SDHQ Motorsports
 190 S McQueen Rd
 Ste 109 Gilbert, AZ 85233
 Phone: 480-633-2929

INSTALLATION INSTRUCTIONS

Product: SDHQ-53-3001-G3

Description: 2007-2021 Toyota Tundra & 2008-2022 Toyota Sequoia Dual Battery Tray Kit

<u>Parts List</u>	<u>Hardware List</u>	<u>Required Tools</u>
(1) Main Battery Mount SDHQ-53-3001-G3-A (1) Blue Sea ML-ACR Mount SDHQ-53-3001-G3-B (1) SDHQ PS Reservoir Mount SDHQ-53-3001-G3-C (1) Tundra PS Reservoir to Tray Mount SDHQ-53-3001-G3-D (1) Bottom Support Doubler Bracket SDHQ-53-3001-G3-E (1) Bottom Support Bracket SDHQ-53-3001-G3-F (1) Upright Support Bracket SDHQ-53-3001-G3-G (1) Bottom Rear Support Bracket SDHQ-53-3001-G3-H (1) SDHQ Auxiliary Battery Hold Down SDHQ-50-3005-U1-A (1) Hardware Package SDHQ-53-3001-G3-HP	(2) 1/4" – 20 x 3/4" S.S. Button Head Bolts (2) 1/4" – 20 S.S. Nylock Nuts (11) 1/4" S.S. SAE Washers (2) 1/4" ID x 1 1/4" OD S.S. Fender Washers (7) M6 – 1.0 x 25mm S.S. Hex Head Bolts (5) M6 – 1.0 S.S. Serrated Flange Nuts (5) 5/16" – 18 x 1" S.S. Button Head Bolts (5) 5/16" S.S. SAE Washers (5) 5/16" – 18 Nut Clips (2) 3/8" – 16 x 9" Threaded Rods (2) 3/8" – 16 S.S. Serrated Flange Nuts (2) 3/8" S.S. with Rubber Washers (1) Quart of Power Steering Fluid (1) 24" Power Steering Hose (1) 17" Power Steering Hose (5) Edge Zip Ties (1) 3" of Door Edge Trim (1) Tube of Anti-Seize	Standard and Metric Sockets 3" and 6" Extensions Wobbly Adapter Ratchet 5/32", 3/16" Allen Bit Flat Head Screw Driver 10mm, 12mm, 14mm Wrench 7/16", 1/2", 9/16" Wrench Siphon Oil Catch Can Shop Rags Wire Strippers/Cutters Center Punch or Sharpie 1/8", 1/4" Drill Bit Drill Red Loctite

Tech Notes

Drilling (2) holes is required.

Use Anti-Seize on all Stainless Steel (S.S.) hardware.

Works with the SDHQ Tundra Air Pumper Kit (SDHQ-53-1100-G3).

If you are running 24F batteries, purchase (1) SDHQ-50-3005-24F Toyota Dual Battery 24F/27F Upgrade.

For ease of wiring, SDHQ-50-3002-U1 is our optional wiring kit. Must be purchased separately or in the Tundra Complete Dual Battery Kit (SDHQ-53-3000-G3)

This kit removes the factory windshield fluid reservoir. Purchase SDHQ-53-1160-G3 to maintain a windshield fluid reservoir. Sequoias using this battery kit and SDHQ-53-1160-G3 will only have one pump location for windshield wiper fluid. The rear window washer pump and on models with the front headlight washer pump will be left disconnected.

Approx. Install Time: 4+ Hours

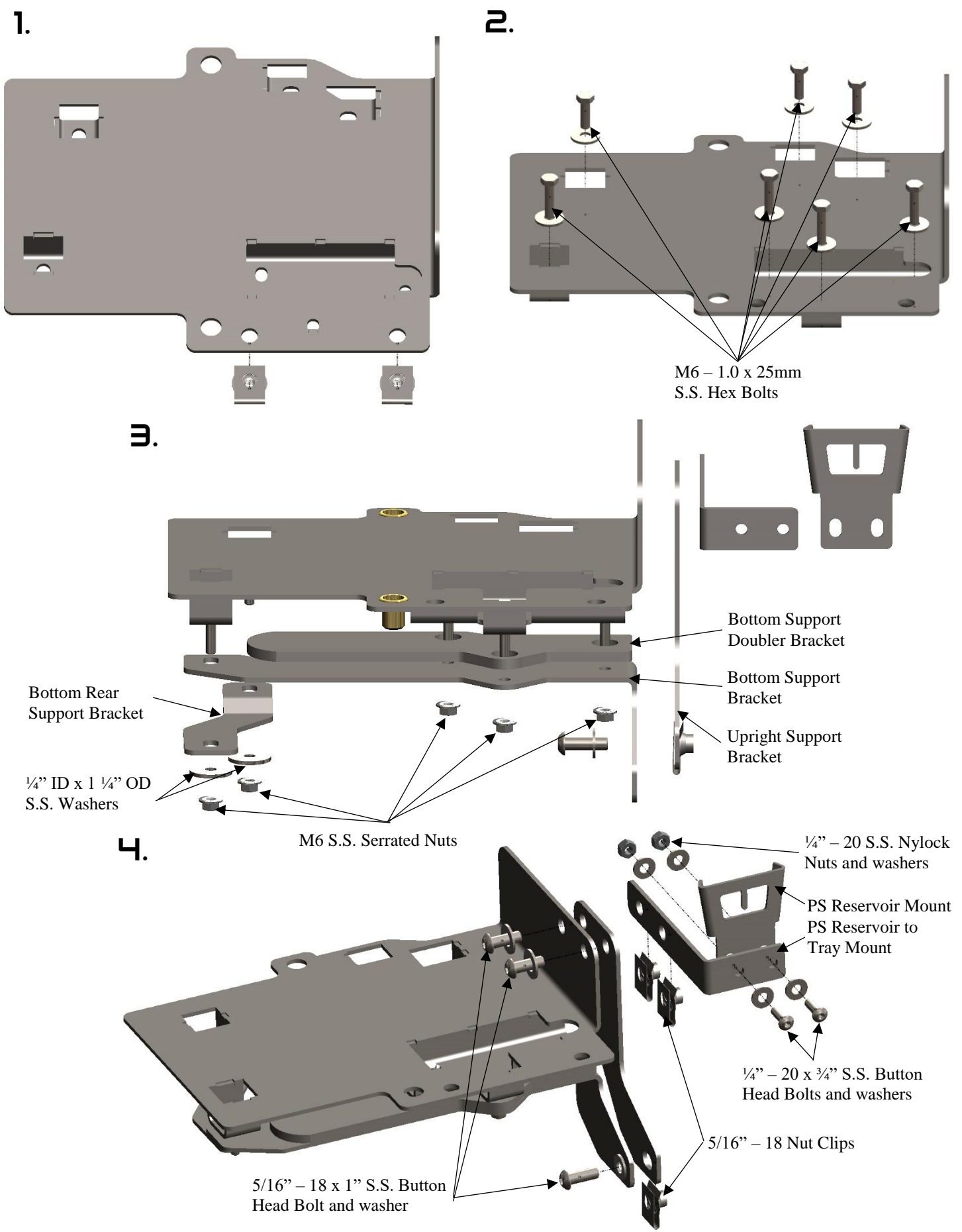

Installation Instructions:

1. Unbox your SDHQ Dual Battery Kit, check over all the parts. Familiarize yourself with the parts and the diagrams on Page 4. Disconnect the vehicle's battery before starting.
2. **Preparing your Tundra.** Remove the (4) bolts on top of the grille using a 10mm socket and ratchet. Remove the (2) panel clips with a flat head screw driver. The grille is now ready to be removed. There are (2) clips on each side of the grille underneath each head light and (3) clips along the bottom of the grille. Start on the driver side and grab underneath the grille below the headlight and pull out to separate the grille from the body. The grille will need to be pushed down towards the ground to release the second clip underneath the headlight. Work your way along the bottom towards the passenger side and release the bottom (3) clips. Release the last (2) clips on the passenger side underneath the headlight.



3. The air dams behind the grille, the passenger side headlight and passenger side headlight filler panel will need to be removed. Remove (4) panel clips on each air dam to remove them. Remove (2) panel clips on the headlight filler panel. Remove the headlight filler panel by pulling it out from the body. Remove (3) 10mm bolts circled below right. The headlight can now be removed. Disconnect the electrical connections and set the headlight aside.

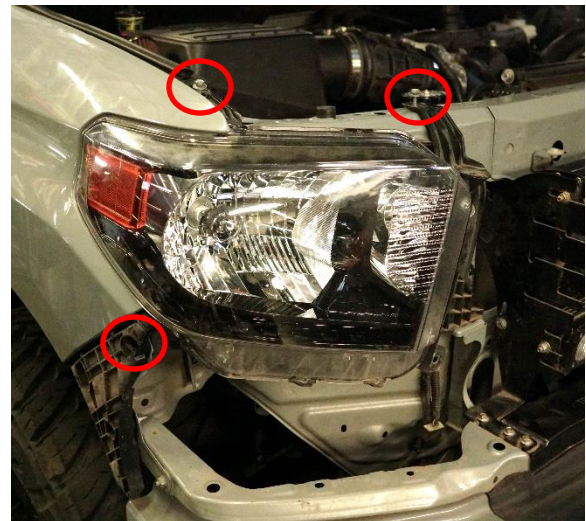

- Remove the (15) 10mm bolts and panel clips from passenger side inner fender liner and remove. Remove the skid plate. This will help in Step 8.

If the SDHQ Tundra Windshield Wiper Bottle Relocation (**SDHQ-53-1160-G3**) was purchased, proceed to Step 1 in those installation instructions.

- Removing the Windshield Fluid Reservoir.** Remove the (3) 10mm bolts securing the windshield fluid reservoir to the top of the fender well. Disconnect the electrical connectors from the windshield fluid reservoir. Disconnect the rubber fluid line from the reservoir and cap it as fluid will spill out. Remove the windshield fluid reservoir from the truck.

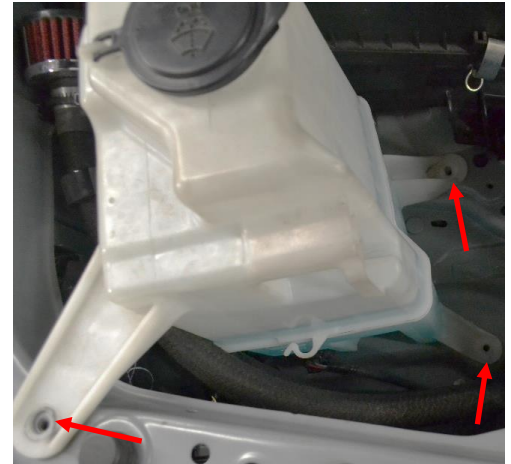

If the SDHQ Power Steering Reservoir Kit (**SDHQ-53-9201-G3**) was previously purchased and installed, proceed to Step 1 in the SDHQ Dual Battery Power Steering Reservoir Mount (**SDHQ-53-9212-G3**) Install Instructions.

- Removing the factory power steering reservoir.** Use a siphon to remove as much power steering fluid as possible. Position your shop rags and oil catch container as necessary. Move the hose clamps down the power steering hoses. Remove the hoses from the reservoir. Remove the (3) 10mm bolts securing the power steering reservoir. Remove the power steering reservoir from the truck.

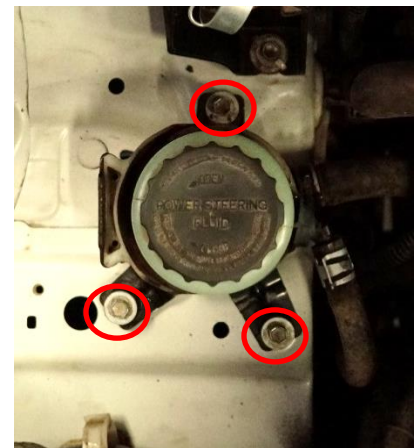

- The power steering reservoir and mount need to be separated. Bend the tab on the mount away from the reservoir and remove the reservoir from the mount.

If the SDHQ Dual Battery Power Steering Reservoir Kit (**SDHQ-53-9211-G3**) was purchased, proceed to Step 2 in those Install Instructions.

- Both of the power steering lines that go to the reservoir need to be replaced with longer lines. Follow the smaller diameter power steering line down towards the frame. Remove the hose clamps from the hard line and remove the power steering line. Repeat this for the larger diameter power steering line. Follow this line down towards to the middle of the engine. It may be easier to access this line from underneath the truck.

- Remove the hose clamps from the factory lines and install them on the supplied lines. Use power steering fluid to help lube the hardline and power steering lines. Install the longer supplied power steering lines, placing the side of the larger diameter hose with the brass fitting closest to the reservoir. Once the power steering lines are installed over the hardline, secure the lines with the factory hose clamps.



10. Removing the intake and Secondary Air Pumper. Use an 8mm socket to remove the hose clamp by the throttle body. Remove (2) 10mm bolts connecting the intake to the top of the fender. The Land Cruiser will have an additional 10mm bolt connecting the intake to the side of the fender. Disconnect the MAF sensor and vacuum lines. Remove the intake and set aside. Remove the (2) 12mm nuts and (2) 12mm bolts attaching the air pumper to the truck.

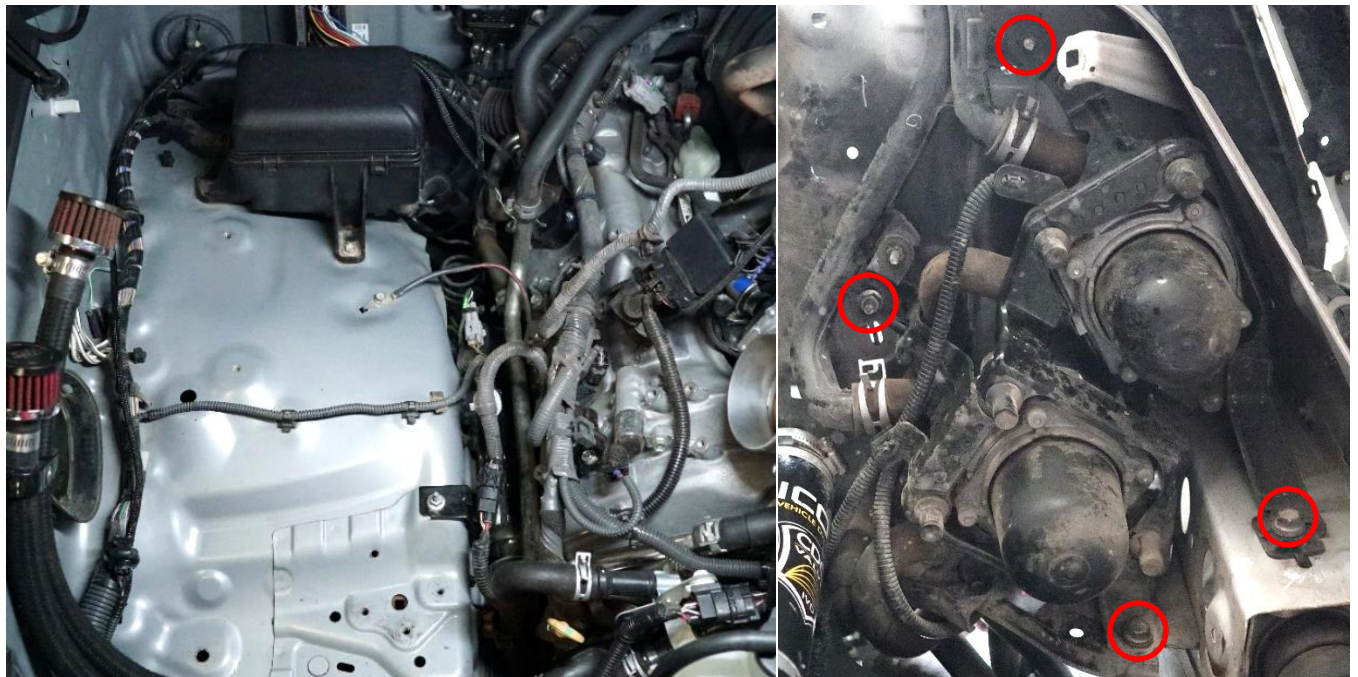

11. Aligning the Dual Battery Tray. The dual battery tray needs to be aligned into position to drill holes for mounting. Position the dual battery tray as pictured below. Mostly thread (3) M6 Hex Head Bolts and (3) 1/4" Washers. Adjust the dual battery tray as far forward and to the passenger fender as possible. Center punch/mark the passenger side (2) mounting holes. Remove the (3) M6 bolts, washers and dual battery tray.

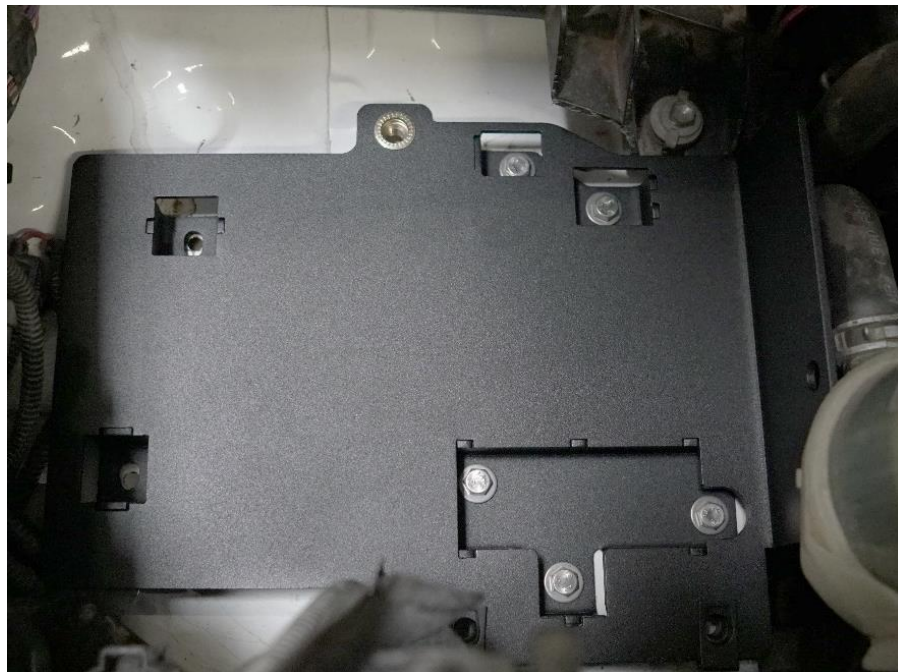

12. Drilling holes. Pre-drill the center punches/marks using a 1/8" drill bit and drill. Use a 1/4" drill bit to finish drilling the sheet metal. Clean up any metal burrs.

Before installing the dual battery tray, some wiring needs to be ran first. Proceed to Step 20 through 25 in the Toyota Dual Battery **Wiring Kit** Installation Instructions (SDHQ-50-3002-U1).



13. With some of the wiring ran, it is time to install the dual battery tray. Begin by installing (2) 5/16" – 18 Nutclips as shown on Page 4, Figure 1. If you have the SDHQ Air Pumper Kit (SDHQ-53-1100-G3), lay it across the fender as shown below. (**Revision 1 Tray shown**)

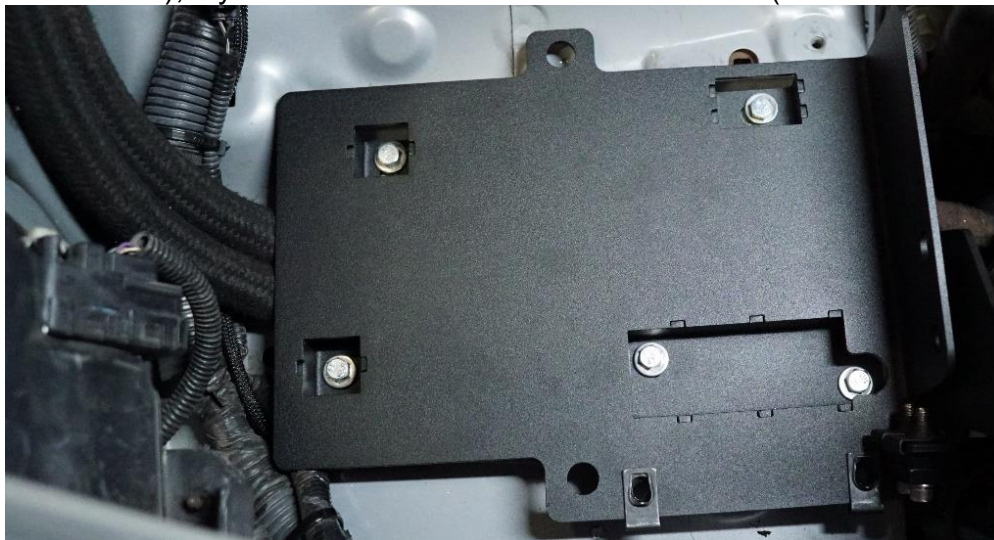

14. Align the dual battery tray and insert/thread (7) M6 x 25mm Hex Head Bolts and (7) 1/4" Washers into the (7) mounting holes in the tray. See Figure 2 on Page 4. Tighten the (5) M6 bolts on the right side of the tray.



Before installing the Blue Sea ML-ACR and Mount, the ML-ACR needs to be wired. Please proceed to Step 26 in the Toyota Dual Battery **Wiring Kit** Installation Instructions (**SDHQ-50-3002-U1**).

If the SDHQ Dual Battery Power Steering Reservoir Kit (**SDHQ-53-9211-G3**) was purchased, proceed to Step 9 in those Install Instructions.

If the SDHQ Tundra Dual Battery Power Steering Reservoir Mount (**SDHQ-53-9212-G3**) was purchased, proceed to Step 3 in those Install Instructions.

- 15. Installing the Power Steering Reservoir.** Attach the PS Reservoir to Tray Mount to the PS Reservoir Mount using (2) 1/4" S.S. Button Head Bolts, (4) 1/4" S.S. Washers and (2) 1/4" S.S. Nylock Nuts as shown below. Install (2) 5/16" Nut Clips on the Tundra PS Reservoir to Tray Mount. See Figure 4 on Page 4.

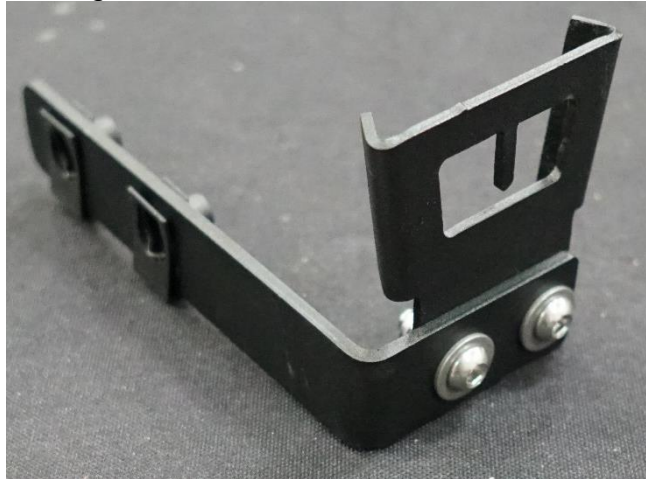

- 16.** Align the Upright Support Bracket between the Main Battery Mount and the PS Reservoir to Tray Mount. Use (2) 5/16" x 1" Button Head Bolts and (2) 5/16" Washers to secure these to the dual battery tray as shown below. Leave loose for now. See Figure 4 on Page 4. Check the transmission cooler lines and adjust them lower if they are rubbing the PS brackets.



17. Align the Bottom Support Doubler Bracket and Bottom Support Bracket underneath the Main Battery Mount as shown below. Thread (3) M6 S.S. Serrated Flange Nuts onto the M6 threads showing through the fender and brackets. Thread (1) 5/16" x 1" Button Head Bolt and (1) 5/16" Washer through the Bottom Support Bracket into the Upright Support Bracket. Tighten the 5/16" bolts and the (3) M6 nuts.

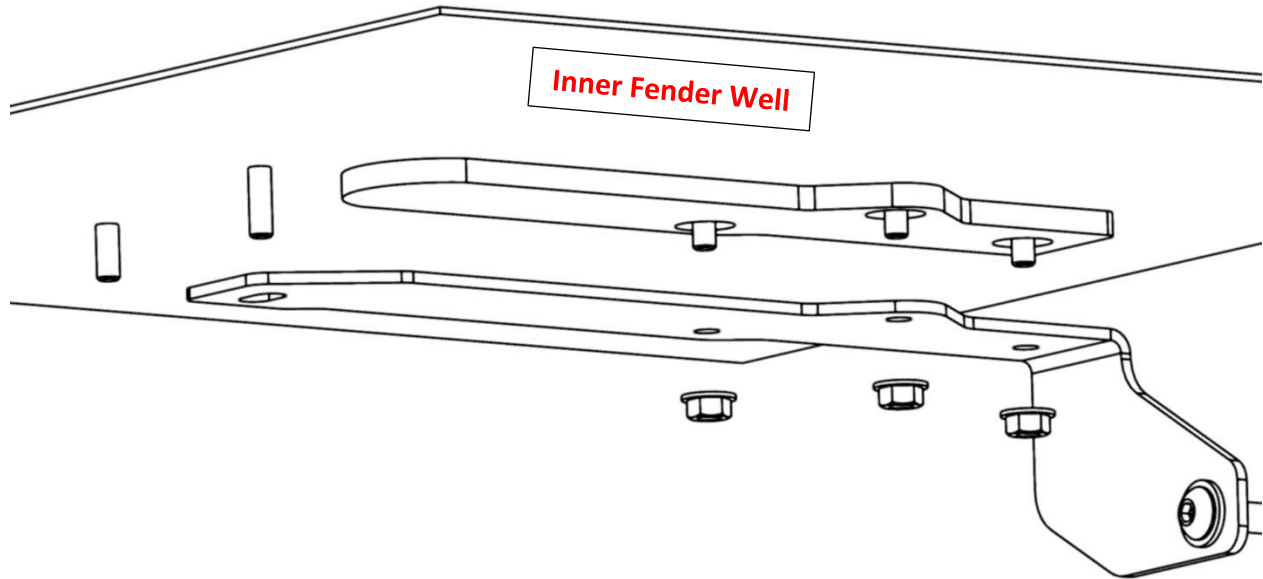

18. Align the Bottom Rear Support Bracket underneath the fender, through both M6 Bolts. Secure the bracket with (2) 1/4" Fender Washers and (2) M6 S.S Serrate Flange Nuts. See Figure 3 on Page 4.

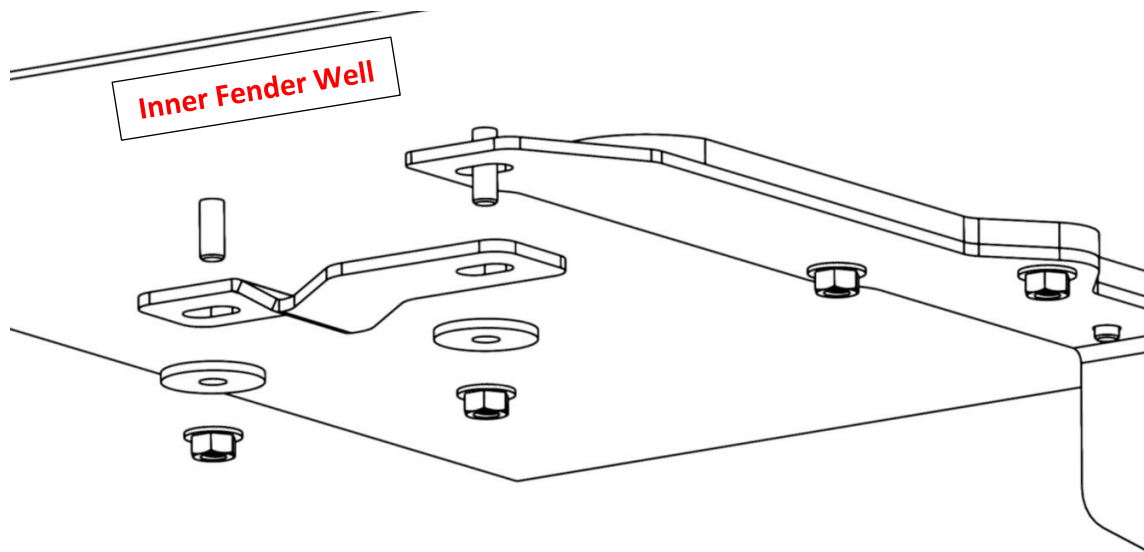

19. Installing the Batteries. Using red Loctite, thread (1) threaded rod into each nutsert. Install your battery into the Main Battery Mount. Place the SDHQ Auxiliary Battery Hold Down on top of the battery. Place (2) 3/8" Washers and thread (2) 3/8" Flange Nuts as pictured below.



Finish Wiring. Proceed to Step 28 in the Toyota [Wiring Kit](#) Installation Instructions (SDHQ-50-3002-U1).

- 20.** Using the supplied power steering fluid, fill up the power steering reservoir to the internal fill line. With the power steering cap off, lift the vehicle so the front wheels are in the air and cycle the steering rack to either side until there is no longer air bubbling into the reservoir. Refill the reservoir as needed. Start the vehicle and check for any leaks. Clean up any spilt fluid.
- 21.** With all the wiring complete, you can start assembling your vehicle. Install your intake and secure it with the (2) 10mm bolts. Secure the intake hose to the throttle body with the 8mm hose clamp. Check all electrical connections and vacuum hoses. Align and secure the Air Pumper with the factory hardware. Install your fender liner with the (15) 10mm bolts and panel clips. Install the headlight and headlight filler panel next, secure it with the panel clips. Connect all of the electrical connections to the headlight and install the headlight. Finally, reinstall the grille and secure it with the 10mm bolts and panel clips.
- 22.** Take your truck out for a drive to get it up to operating temperatures and finish removing the air out of the power steering lines. The Reservoir Body and Cap will be **EXTREMELY** hot at operating temperatures. Refill the reservoir if needed to the hot max line. Check the reservoir fluid after 50 miles. Installation is COMPLETE! Enjoy your new SDHQ Dual Battery Kit!

*****Double check all hardware is installed correctly and tight*****

*****Re-torque ALL bolts after 100 miles*****



190 S McQueen Rd
Ste 109 Gilbert, AZ 85233
Phone: 480-633-2929 | Fax: 480-633-1791
www.sdhqoffroad.com

Follow us on:



Facebook



Instagram

For questions or help with the installation, please call SDHQ Offroad @ 480-633-2929
Mon.–Fri. 8:00am–5:30pm and Sat. 8:00am–3:30pm Arizona Time. www.sdhqoffroad.com