



SDHQ Motorsports
190 S McQueen Rd
Ste 109 Gilbert, AZ 85233
Phone: 480-633-2929

Product Packing List

Product: *SDHQ-50-3005-24F*

Description: **Toyota Dual Battery 24F/27F Upgrade**

_____ (1) SDHQ J-Hook Extension

SDHQ-00-3005-U1

_____ (1) Hardware Package

SDHQ-50-3005-24F

_____ (2) 3/8" - 16 x 10" Threaded Rods

Inspected and Packaged By: _____ **Date:** _____

For questions or help with the installation, please call SDHQ Offroad @ 480-633-2929
Mon.-Fri. 8:00am-5:30pm and Sat. 8:00am-3:30pm Arizona Time. www.sdhqoffroad.com

Included in **SDHQ-00-3005-U1**:

_____ (2) 5/8" Machined Hex Extension

SDHQ-00-3005-U1-A

_____ (1) Hardware Package

SDHQ-00-3005-U1-B

_____ (2) ¼" - 20 x 2 5/16" Zinc Coated J-Hook

_____ (2) ¼" - 20 x 4" Zinc Coated J-Hook with Nut

_____ (2) ¼" - 20 x 1 ¾" S.S. Button Head Bolt



SDHQ Motorsports
 190 S McQueen Rd
 Ste 109 Gilbert, AZ 85233
 Phone: 480-633-2929

INSTALLATION INSTRUCTIONS

Product: SDHQ-50-3005-24F

Description: Toyota Dual Battery 24F/27F Upgrade

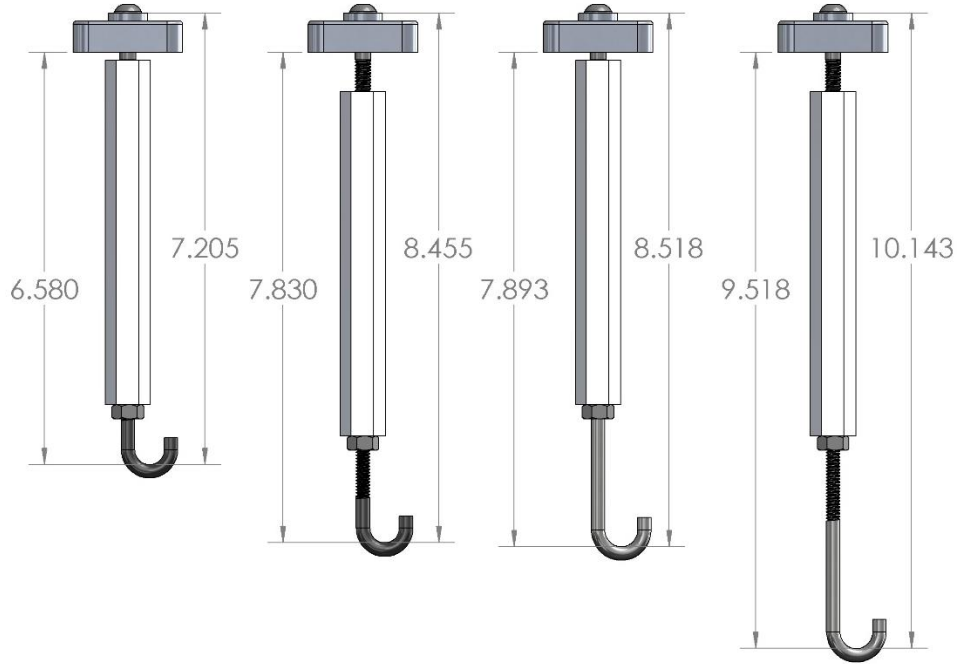

<u>Parts List</u>	<u>Hardware List</u>	<u>Required Tools</u>
(1) SDHQ J-Hook Extension SDHQ-00-3005-U1-A (1) Hardware Package SDHQ-50-3005-24F	(2) 3/8" – 16 x 10" Threaded Rods	Tape Measure 10mm Wrench 9/16" Wrench 5/32" Hex Drive

Tech Notes

Designed to fit Group 24, 27 or 35 in the factory location.
 For use with SDHQ Dual Battery Kits and Toyota 34R Battery Hold Down (SDHQ-50-3005-U1).
 Approx. Install Time: 1 Hour

*****READ ALL INSTRUCTIONS THOROUGHLY FROM START TO FINISH BEFORE BEGINNING INSTALLATION!*****

For questions or help with the installation, please call SDHQ Offroad @ 480-633-2929
 Mon.–Fri. 8:00am–5:30pm and Sat. 8:00am–3:30pm Arizona Time. www.sdhqoffroad.com

Installation Instructions:

1. Unbox your SDHQ Battery Hold Down Upgrade and J-Hook Extension. Check over all parts and hardware. Familiarize yourself with them and the diagrams on page 3.
2. **Preparing your Vehicle.** In your vehicle's engine bay, remove the (2) 10mm nuts and (1) 10mm bolt on the factory battery hold down. Remove the factory hold down and J-Hooks.
3. Place the Billet Battery Hold down on top of your battery. With a tape measure, measure the front and rear J-hook mounting holes to the top of the hold down (add ~1/8" for the Aluminum Adapters). Use the diagrams to determine if you need the 2 5/16" J-Hook or 4" J-Hook. Install the SDHQ Billet Aluminum Adapters through the SDHQ Battery Hold Down. Thread a J-Hook with a nut into the Hex Extension to approximate length. Use the nut to secure the J-Hook on the Extension. Insert the 1/4" bolt through the front Aluminum Adapter in the Billet Hold Down and thread the top of the Hex Extension onto the bolt. Repeat for the rear of the Hold Down.
4. **Installing the SDHQ Battery Hold Down.** Place the SDHQ Hold Down over the battery. While tightening the 1/4" bolts, hook the J-Hooks to the factory tie downs. Be sure all hardware is tight.
5. From the SDHQ Battery Hold Down Upgrade package: (1) 1/4" – 20 x 7" J-Hook, (1) 1/4" – 20 S.S. Nut and (2) M6 – 1.0 Nut will not be used.
6. **Dual Battery Hold Down.** Install (2) 3/8" – 16 x 10" Threaded Rods in place of the 9" Threaded Rods supplied in the Dual Battery Kit.
7. **Complete!** Your Toyota Battery Hold Down Upgrade is finished.

*****Double check all hardware is installed correctly and tight***
Re-torque ALL bolts after 100 miles**



**190 S McQueen Rd
Ste 109 Gilbert, AZ 85233
Phone: 480-633-2929 | Fax: 480-633-1791
www.sdhqoffroad.com**

Follow us on:



Facebook



Instagram

For questions or help with the installation, please call SDHQ Offroad @ 480-633-2929
Mon.–Fri. 8:00am–5:30pm and Sat. 8:00am–3:30pm Arizona Time. www.sdhqoffroad.com