



SDHQ Motorsports
190 S McQueen Rd
Ste 109 Gilbert, AZ 85233
www.SDHQoffroad.com

Product Packing List

Product: SDHQ-33-1202-G5

Description: 2019-current Ram 1500 & 2021-current RAM 1500 TRX Dual Behind the Grille 10" Light Mount

_____	(1) Driver Side Mount A	SDHQ-33-1202-G5-AD
_____	(1) Driver Side Mount B	SDHQ-33-1202-G5-BD
_____	(1) Passenger Side Mount A	SDHQ-33-1202-G5-AP
_____	(1) Passenger Side Mount B	SDHQ-33-1202-G5-BP
_____	(2) Lower Backer Mount	SDHQ-33-1202-G5-C
_____	(2) 3D Printed Shutter Motor Arm	SDHQ-00-1202-G5I
_____	(1) Hardware Package	SDHQ-33-1202-G5-HP
_____	(2) M6-1.0mm x 20mm S.S. Button Head Bolt	
_____	(2) M6 S.S. Oversized Washers	
_____	(4) 5/16"-18 x 1-1/4" S.S. Button Head Bolt	
_____	(4) 5/16" S.S. Oversized Washers	
_____	(2) #8 Nylon Unthreaded Spacer, 1/4" OD, 7/8" Long	
_____	(2) #8-32 x 1-1/2" S.S. Button Head Bolt	
_____	(2) #8-32 18-8 S.S. Nylock Nut	
_____	(2) #8 18-8 S.S. Washer	
_____	(32) 1/4" SAE S.S. Washers	
_____	(4) 7/16" Billet Aluminum Spacers	
_____	(2) #10-32 x 1 3/4" S.S. Button Head Bolts	
_____	(2) #10-32 S.S. Nylock Nuts	
_____	(1) Tube of Anti-Seize	

Inspected and Packaged By: _____ Date: _____

For questions or help with the installation, please email help@sdhqoffroad.com
Store front hours: Mon. – Fri. 8:00am – 5:30pm and Sat. 9:00am – 2:00pm Arizona Time.

For questions or help with the installation, please email help@sdhqoffroad.com
Store front hours: Mon. – Fri. 8:00am – 5:30pm and Sat. 9:00am – 2:00pm Arizona Time.



SDHQ Motorsports
 190 S McQueen Rd
 Ste 109 Gilbert, AZ 85233
www.SDHQoffroad.com

INSTALLATION INSTRUCTIONS

Product: SDHQ-33-1202-G5

Description: 2019-current Ram 1500 & 2021-current RAM 1500 TRX Dual Behind the Grille 10" Light Mount



Parts List	Hardware List	Required Tools
(1) Driver Side Mount A SDHQ-33-1202-G5-AD (1) Driver Side Mount B SDHQ-33-1202-G5-BD (1) Passenger Side Mount A SDHQ-33-1202-G5-AP (1) Passenger Side Mount B SDHQ-33-1202-G5-BP (2) Lower Backer Mount SDHQ-33-1202-G5-C (2) 3D Printed Shutter Motor Arm SDHQ-00-1202-GS1 (1) Hardware Package SDHQ-33-1202-G5-HP	(2) M6-1.0mm x 20mm S.S. Button Head Bolt (2) M6 S.S. Oversized Washers (4) 5/16"-18 x 1-1/4" S.S. Button Head Bolt (4) 5/16" S.S Oversized Washers (2) #8 Nylon Unthreaded Spacer, 1/4" OD, 7/8" Long (2) #8-32 x 1-1/2" S.S. Button Head Bolt (2) #8-32 18-8 S.S. Nylock Nut (2) #8 18-8 S.S. Washer (32) 1/4" SAE S.S. Washers (4) 7/16" Billet Aluminum Spacers (2) #10-32 x 1 3/4" S.S. Button Head Bolts (2) #10-32 S.S. Nylock Nuts (1) Tube of Anti-Seize	10mm and 7/16" sockets Ratchet 7/16" wrench 6" extension Swivel extension Panel removal tools Flat head screw driver Level Straight edge Medium Strength Loctite

Tech Notes

Use Anti-Seize on all hardware.

See diagrams on next page for guidance on what slots to use for your truck

"Longhorn" style grille cannot run Dual OnX6 light bars **AND** Dual S8 light bars, but **CAN** run quad S8s

For ONx6 and other light bars narrower than 11-5/8", Use the 1/4" washers between the lights and mounts

If your truck has Active Grill Shutters, you will need to keep your motor from this assembly or you will have a CEL

Approximate Install Time: 2+ Hours (not including wiring)

*****READ ALL INSTRUCTIONS THOROUGHLY FROM START TO FINISH BEFORE BEGINNING INSTALLATION! *****

For questions or help with the installation, please email help@sdhqoffroad.com
 Store front hours: Mon. – Fri. 8:00am – 5:30pm and Sat. 9:00am – 2:00pm Arizona Time.

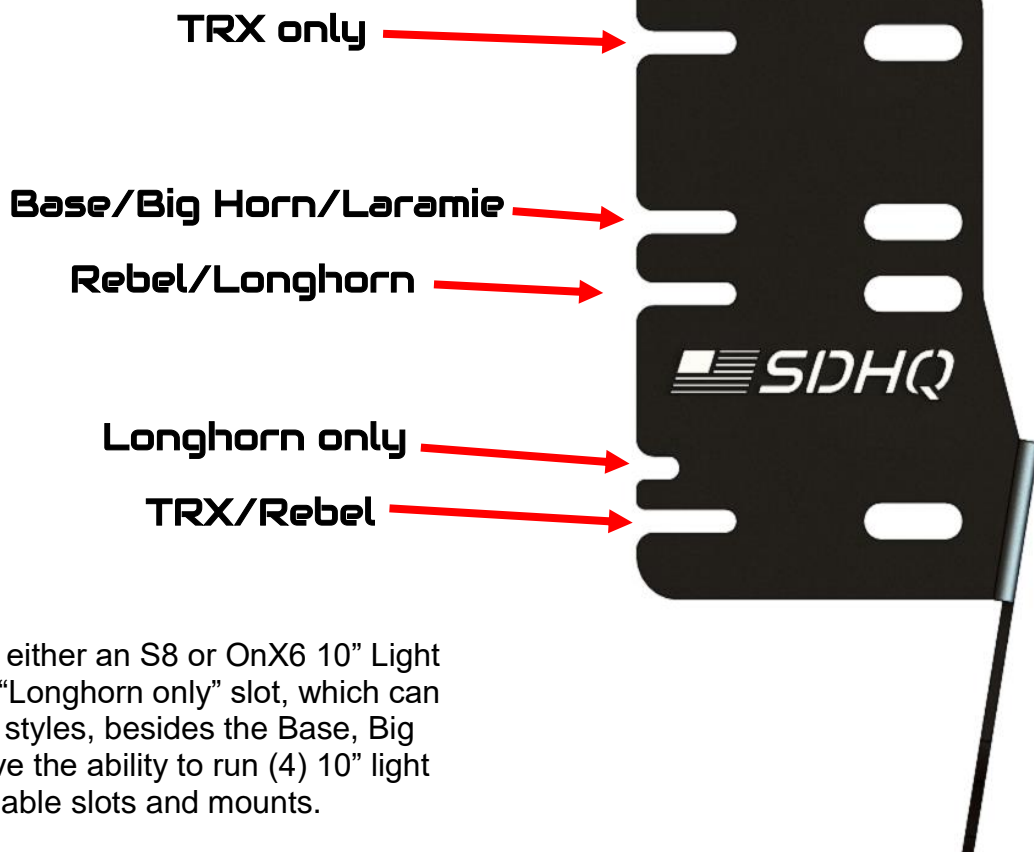
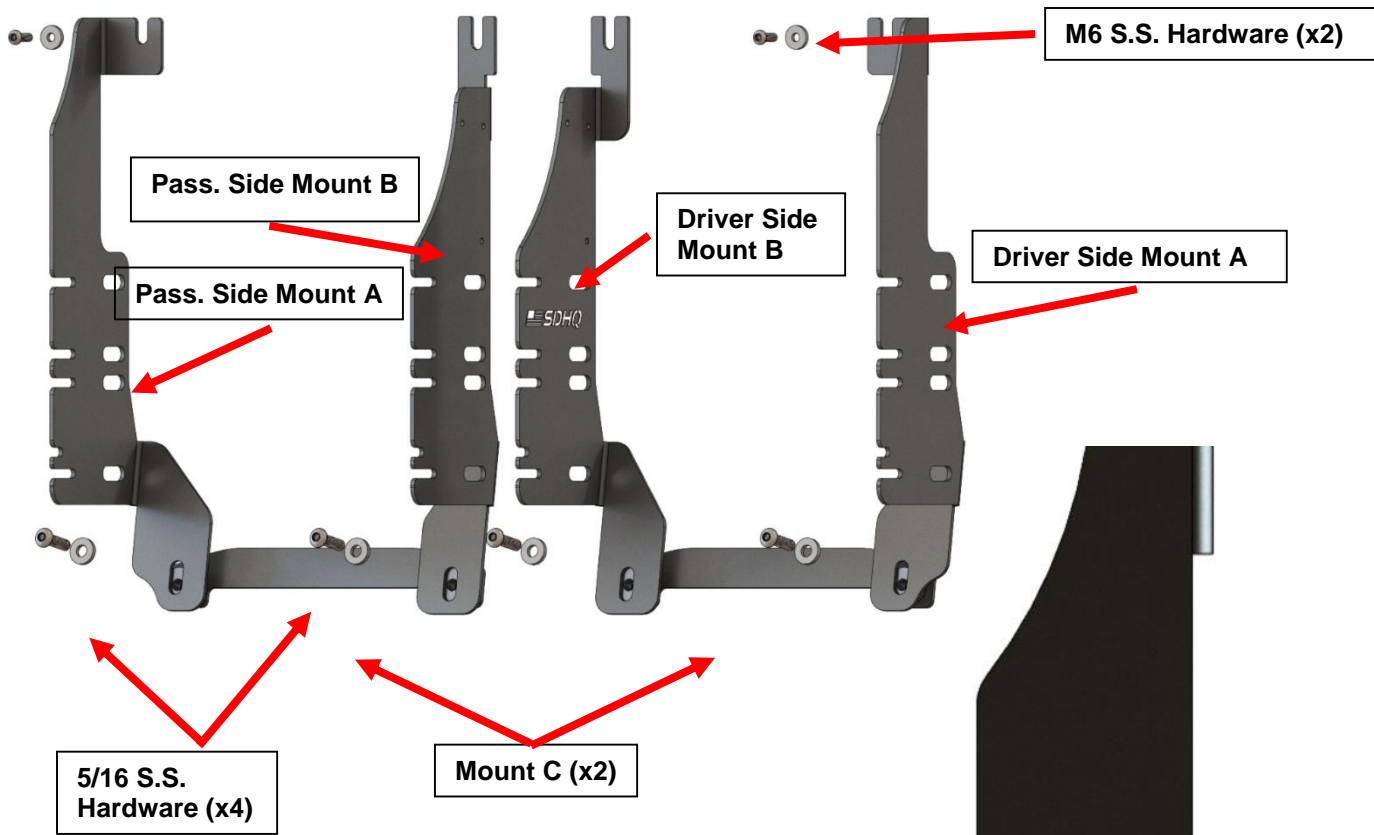

Note: All slots can use either an S8 or OnX6 10" Light Bar, **except** the lower "Longhorn only" slot, which can only fit an S8. All grille styles, besides the Base, Big Horn and Laramie, have the ability to run (4) 10" light bars between the available slots and mounts.

For questions or help with the installation, please email help@sdhqoffroad.com
 Store front hours: Mon. – Fri. 8:00am – 5:30pm and Sat. 9:00am – 2:00pm Arizona Time.

*****READ ALL INSTRUCTIONS THOROUGHLY FROM START TO FINISH BEFORE BEGINNING INSTALLATION! *****

1. **Remove the Grille-** Start by removing the (16) plastic clips that hold the cowl to the truck

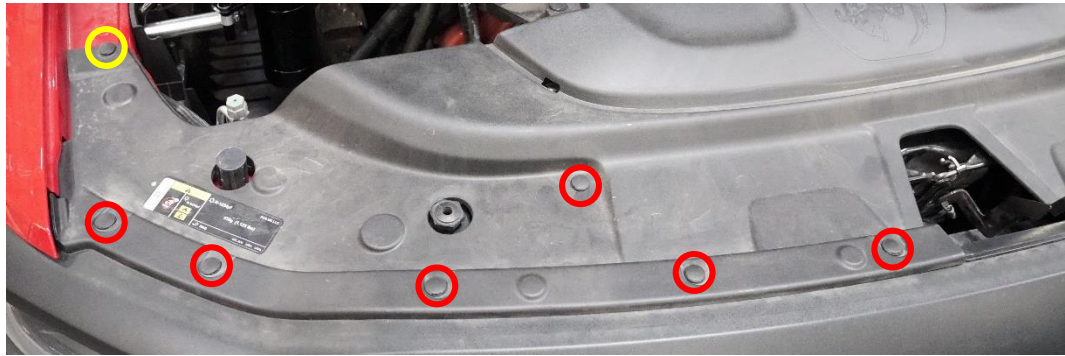

2. Next remove the (8) 10mm bolts and (2) clips holding in the upper trim and upper grille assembly. Gently pull the upper trim towards the front of the vehicle and set aside.

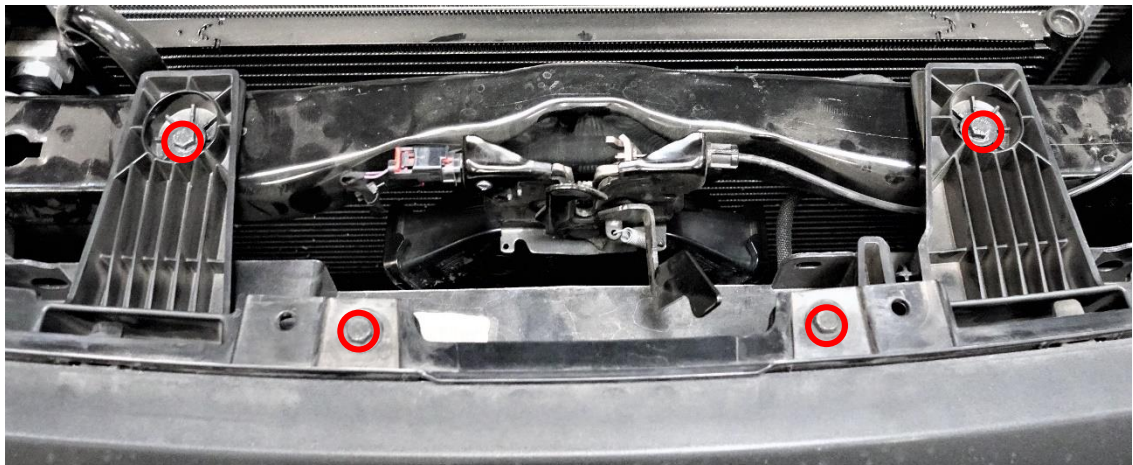

For questions or help with the installation, please email help@sdhqoffroad.com
Store front hours: Mon. – Fri. 8:00am – 5:30pm and Sat. 9:00am – 2:00pm Arizona Time.

- Unclip the painted plastic under the headlight using your panel removal tool, starting from the grill side and working your way out to the fender. It is not necessary to fully remove this panel. (Note: This panel is particularly tight, carefully work all the clips one at a time.)
- Use your 10mm socket and swivel extension to unbolt the (3 per side) silver bolts on the bottom of the grill, formerly covered by the painted plastic panel. Then unbolt the (1 per side) remaining bolts on the top of the grille.

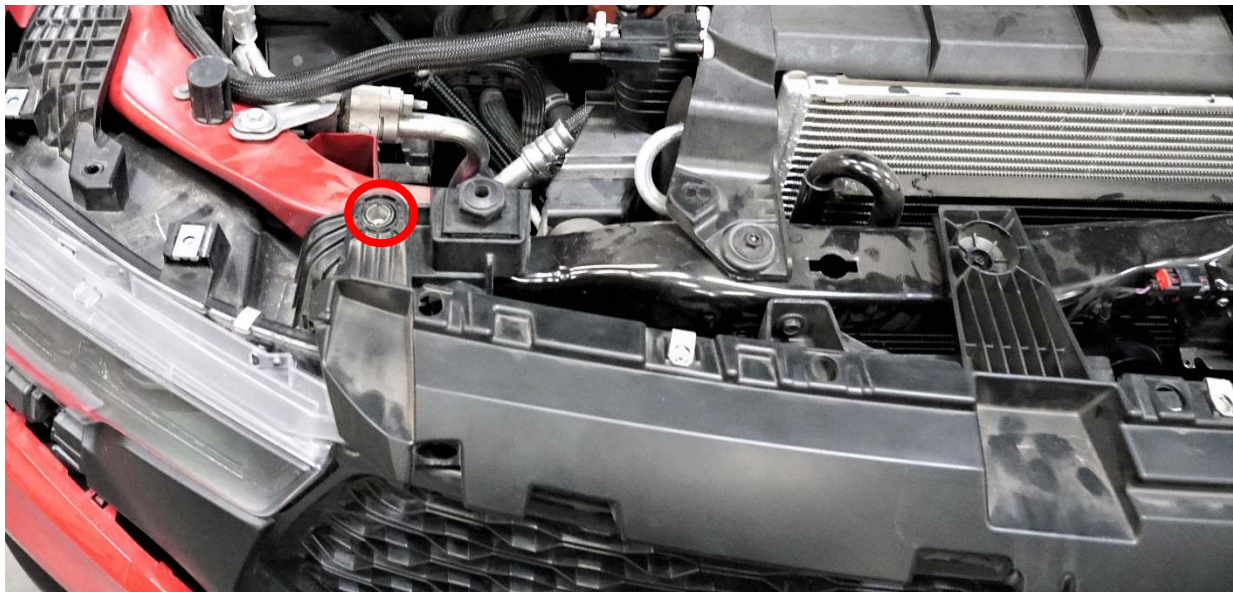
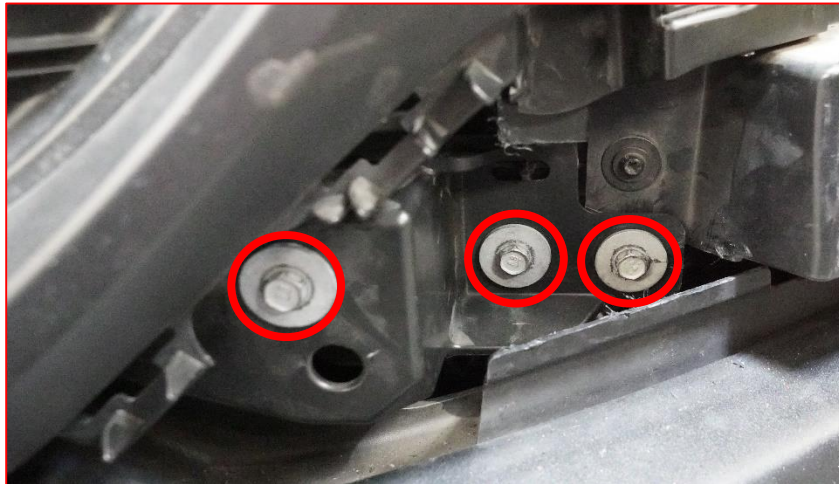

- Unclip any connectors behind the grille, remove grille and set aside.

For questions or help with the installation, please email help@sdhqoffroad.com
Store front hours: Mon. – Fri. 8:00am – 5:30pm and Sat. 9:00am – 2:00pm Arizona Time.

6. **Remove Active Grille Shutter Frame.** Use your panel removal tool to remove the (4) push in clips and 10mm socket to unbolt the (4) bolts holding in the active grille shutter frame. If you have a TRX then you can discard this frame now and skip to **Step 10**. If you have any other Ram 1500 besides a TRX, unplug the shutter motor and set frame on a table.

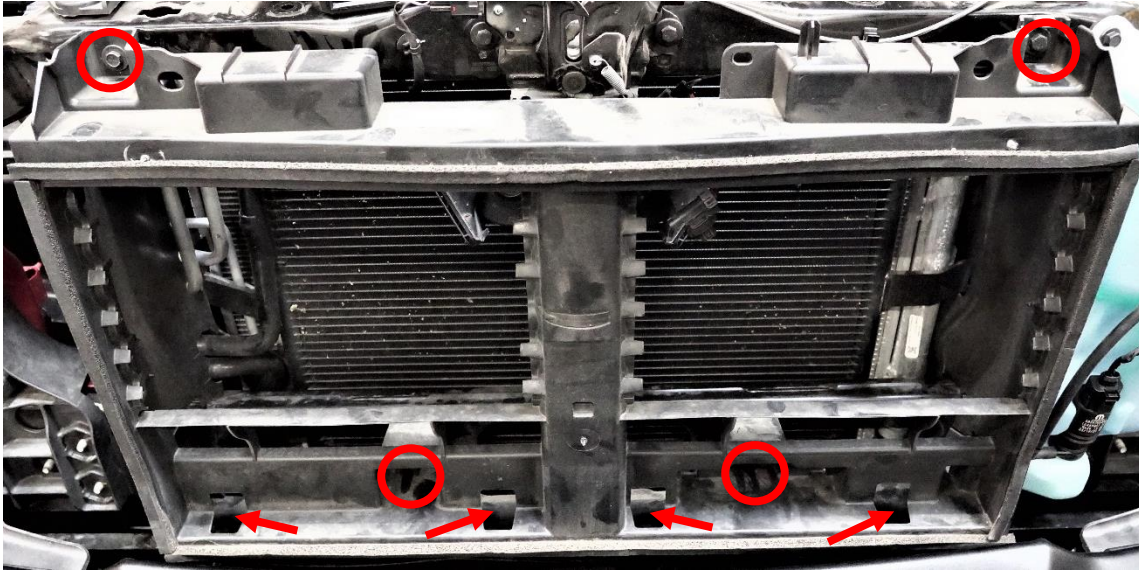

7. **Removing Active Grill Shutter motor.** First locate the plastic cover on the front of the shutter frame and slide it out of its spot as shown. Then using your panel removal tool, pry the outside edge of the frame to release the outside of the (2) shutters directly connected to the motor. Now unclip the (12) tabs holding the shutters to the inside of the frame and discard the cover. Fully remove the (2) shutters directly connected to the motor and now free the motor from the frame by pulling toward you.

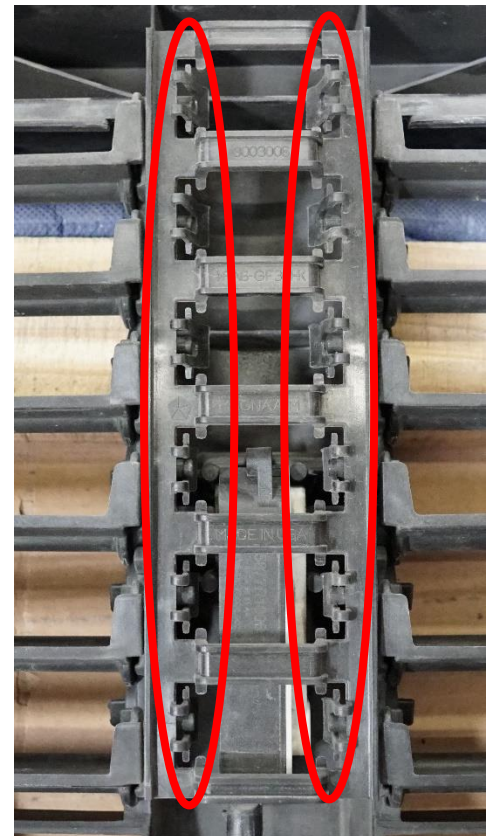
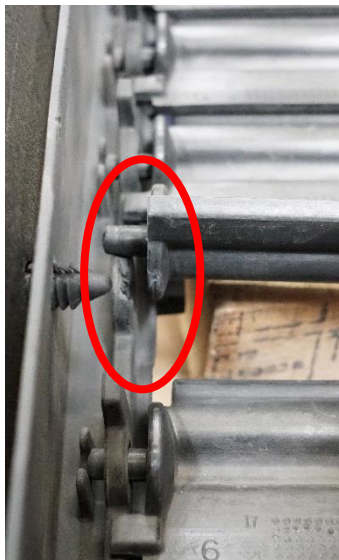

8. With your freed shutter motor, plug it back into the vehicle and cycle the key on waiting for the motor to actuate itself. Once actuated cut off the shown mounting holes to provide clearance for the motor stoppers.



9. Place the (2) 3D Printed Shutter Motor Arms into the motor as shown, failure to place the motor stoppers in the correct position will result in a check engine light and resetting the motor stoppers in the motor is needed. Once installed in the motor use the supplied (2) #10-32 x 1-1/2" bolts through the ends and tighten with nylock nuts. **Once the motor stoppers are installed, before mounting the motor to the vehicle, cycle the key on and let the motor actuate to test for a check engine light. If a CEL is present remove the stoppers and reactivate the motor to reset position. Install the stoppers angled the other direction and check for CEL. **(Note:** Be sure to run the bolts in with the heads on the white side of the motor)



10. Take either Driver or Passenger Mount B and the #8 bolts, nuts, spacers and washers, along with your removed shutter motor, and bolt the motor to the light mount with the white side facing the mount. See picture for positions of hardware.

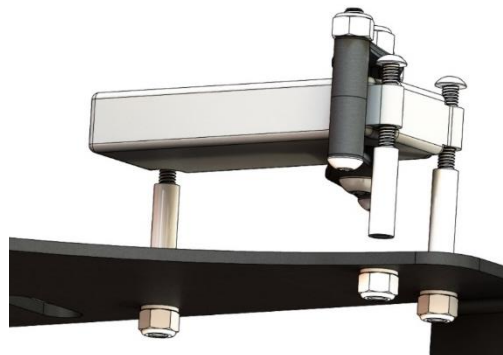

For questions or help with the installation, please email help@sdhqoffroad.com
Store front hours: Mon. – Fri. 8:00am – 5:30pm and Sat. 9:00am – 2:00pm Arizona Time.

11. Now you will need to temporarily unbolt the coolant reservoir on the passenger side of the grill opening. Unbolt the (2) 10mm bolts from the top and bottom of the reservoir and slide it upward out of its mount, then set aside. You do NOT have to open the cooling system.

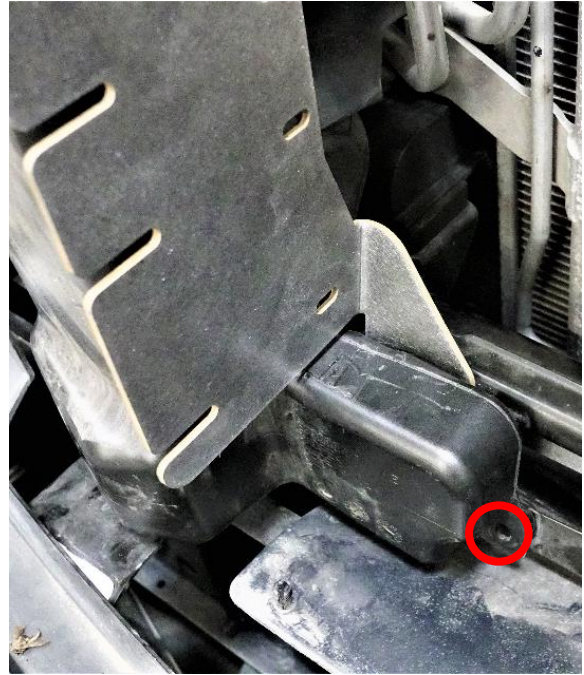

12. **Installing the Brackets.** Start by loosening the (2) 10mm bolts holding on the hood latch, then carefully bend the bracket holding both horns backwards, toward the radiator. Now, slide the Driver and Passenger Side Mount B into place **behind** the hood latch and snug the hood latch bolts up so that the mounts won't fall. Similarly, using the supplied M6 bolts and washers, bolt the Driver and Passenger Mount A into the upper bolt holes on the core support.

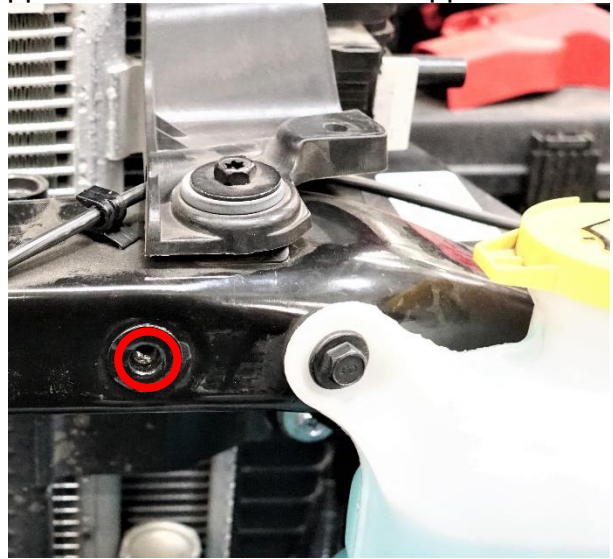
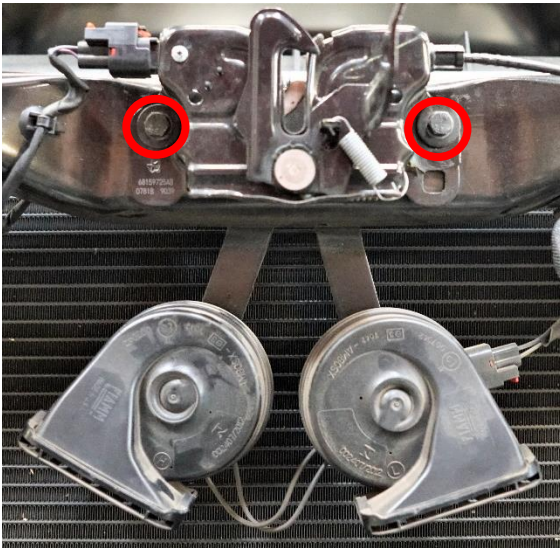

13. Now place both Lower Backer Mounts into the lower core support with the weld nuts facing toward the radiator and bolt them through Mounts on A & B on the Driver and Passenger sides. (Note: Be sure to push the backer up into the core support as much as possible when installing)



14. Before tightening all the hardware, take your straight edge and level, then set them in a slot and level your mounts with your truck side to side. Then tighten all hardware. (Note: Place your desired lights in their slots to check fitment, there is a small amount of adjustability in the mounts for different styles of lights)



15. **Install Light Bars.** If you are mounting an OnX6 10" light bar then you need to place 1/4" washers between the light and the mount. Place your lights in the appropriate slots as seen on Page 4, some models can run (4) lights per truck (see picture below).

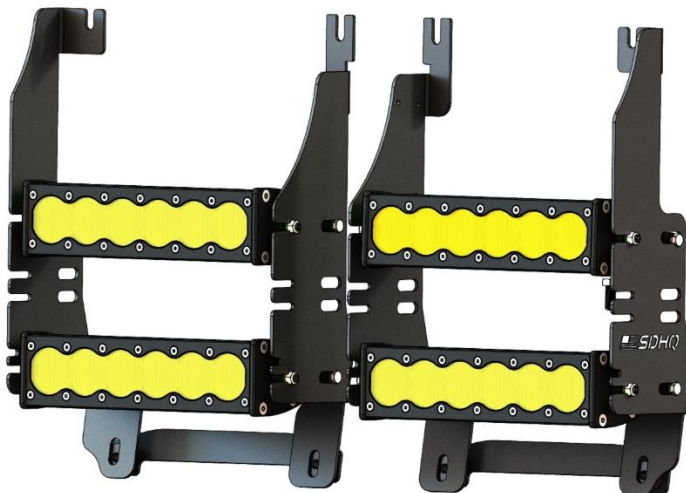

16. Wire up your lights and reassemble the truck in reverse order. Enjoy your **SDHQ Built Behind the Grille Dual Light Mount!** (Shown below is a quad light bar setup for a Ram Rebel).

For questions or help with the installation, please email help@sdhqoffroad.com
Store front hours: Mon. – Fri. 8:00am – 5:30pm and Sat. 9:00am – 2:00pm Arizona Time.

*****Double check all hardware is installed correctly and tight*****

*****Re-torque ALL bolts after 100 miles*****



190 S McQueen Rd
Ste 109 Gilbert, AZ 85233
www.sdhqoffroad.com

Follow us on:



Facebook



Instagram

For questions or help with the installation, please email help@sdhqoffroad.com
Store front hours: Mon. – Fri. 8:00am – 5:30pm and Sat. 9:00am – 2:00pm Arizona Time.