



SDHQ Motorsports
190 S McQueen Rd
Ste 109 Gilbert, AZ 85233
www.SDHQoffroad.com

Product Packing List

Product: *SDHQ-15-3003-G5*

Description: SDHQ Built 2019-Current Ford Ranger Complete Billet Battery Terminal and Distribution Kit

_____ (1) Billet Negative Sensor Terminal	SDHQ-02-3003-TS1
_____ (1) Billet Negative Distribution Block	SDHQ-02-3003-D2-N
_____ (1) 32" 2 AWG Negative Wire	SDHQ-02-3302-B32-13
_____ (1) Hardware Package	SDHQ-15-3003-G5-HP
_____ (1) Distribution Block Mount	SDHQ-15-3003-G5-A
_____ (1) M6 - 1.0 x 35mm S.S. Hex Head Bolt	
_____ (1) 1" OD x .5" Tall Plastic Spacer	
_____ (1) M6 S.S. Washer	
_____ (1) M8 - 1.25 Serrated Flange Head Nut	
_____ (1) M8 - 1.25 x 30mm S.S. Socket Head Bolt	
_____ (2) 1/4" - 20 x 1/2" S.S. Hex Head Bolt	
_____ (2) 1/4" S.S. Washer	
_____ (1) 5/16" - 18 x 3/4" S.S. Hex Head Bolt	
_____ (1) 5/16" S.S. Washer	
_____ (1) 3/8" - 16 x 2" S.S. Hex Head Bolt	
_____ (2) 3/8" S.S. Washers	
_____ (1) 3/8" - 16 S.S. Nuts	
_____ (1) Small Tube of Anti-Seize	
_____ (1) Black Post Washer	
_____ (1) 5/16" - 18 x 1 1/2" Battery Terminal Bolt	
_____ (1) 5/16" - 18 Battery Shoulder Nut	
_____ (1) M6 - 1.0 SS Serrated Flange Head Nut	

Inspected and Packaged By: _____ Date: _____

For questions or help with the installation, please email help@sdhqoffroad.com
Mon.-Fri. 8:00am-5:30pm and Sat. 8:00am-3:30pm Arizona Time. www.sdhqoffroad.com

INSTALLATION INSTRUCTIONS

Product: SDHQ-15-3003-G5

Description: SDHQ Built 2019'-Current Ford Ranger Complete Billet Battery Terminal and Distribution Kit

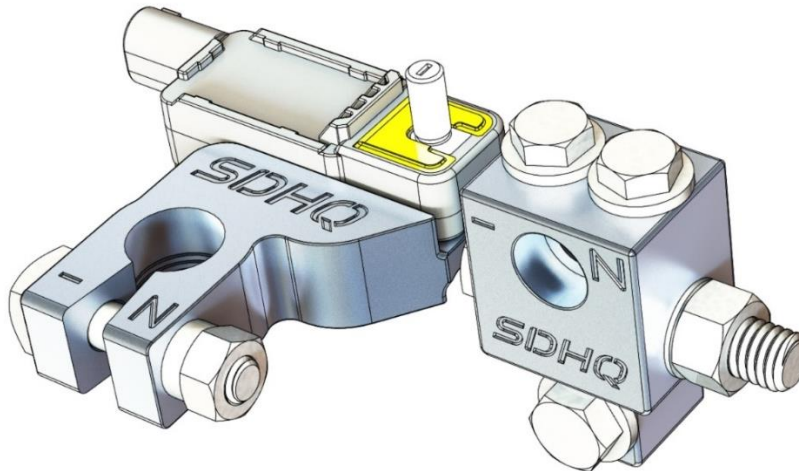

Parts List	Hardware List	Required Tools
(1) Billet Terminal Sensor SDHQ-02-3003-TS1 (1) Billet Distribution Block SDHQ-02-3003-D2-N (1) 32" 2 AWG Negative Wire SDHQ-02-3304-B32-13 (1) Distribution Block Mount SDHQ-15-3003-G5-A (1) Hardware Kit SDHQ-13-3003-G13-HP	(1) M6 - 1.0 x 35mm S.S. Hex Head Bolt (1) 1" OD x .5" Tall Plastic Spacer (1) M6 S.S. Washer (1) M8 - 1.25 Serrated Flange Head Nut (1) M8 - 1.25 x 30mm S.S. Socket Head Bolt (2) 1/4" - 20 x 1/2" S.S. Hex Head Bolt (2) 1/4" S.S. Washer (1) 5/16" - 18 x 3/4" S.S. Hex Head Bolt (1) 5/16" S.S. Washer (1) 3/8" - 16 x 2" S.S. Hex Head Bolt (2) 3/8" S.S. Washers (1) 3/8" - 16 S.S. Nuts (1) Small Tube of Anti-Seize (1) Black Post Washer (1) 5/16" - 18 x 1 1/2" Battery Terminal Bolt (1) 5/16" - 18 Battery Shoulder Nut (1) M6 SS Serrated Flange Head Nut	7/16", 1/2", 9/16" Sockets/wrenches 10mm, 13mm Sockets/wrenches E16 Socket Ratchet 6mm Hex Key Rubber Mallet Pliers

Tech Notes

Bolded Hardware listed is for installing the mount and is sealed separately from the other hardware used in the assembly of the billet battery terminals.

Apply Anti-Seize to all stainless hardware.

Follow the Torque Specifications on the bottom of Page 7.

Factory positive terminal/bracket will not be replaced in this kit.

This kit is designed for batteries with the Ford "BMS" Negative Terminal Sensor.

Approx. Install Time: 1 Hour

For questions or help with the installation, please email help@sdhqoffroad.com
 Mon.-Fri. 8:00am-5:30pm and Sat. 8:00am-3:30pm Arizona Time. www.sdhqoffroad.com

SDHQ Negative Distribution Block

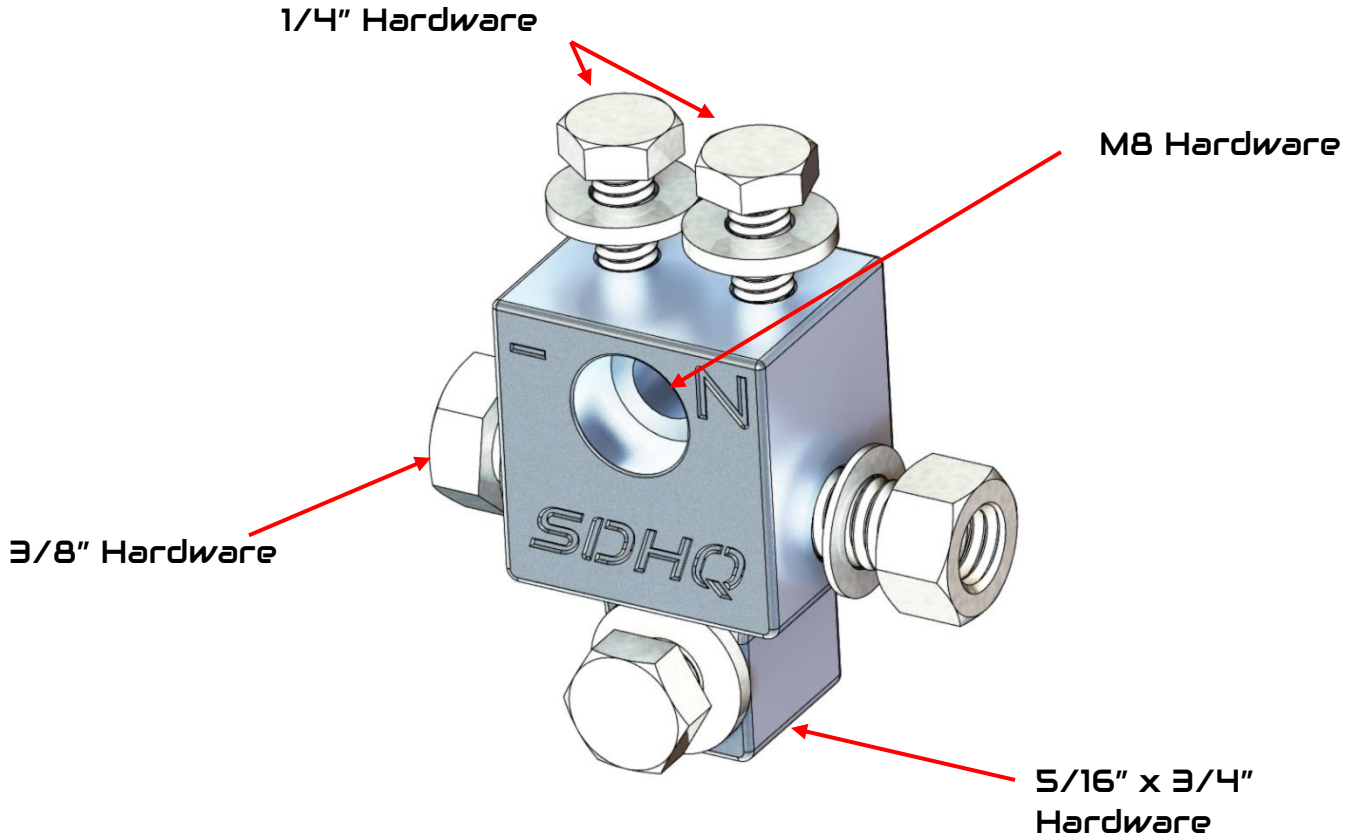

SDHQ Negative Sensor Terminal

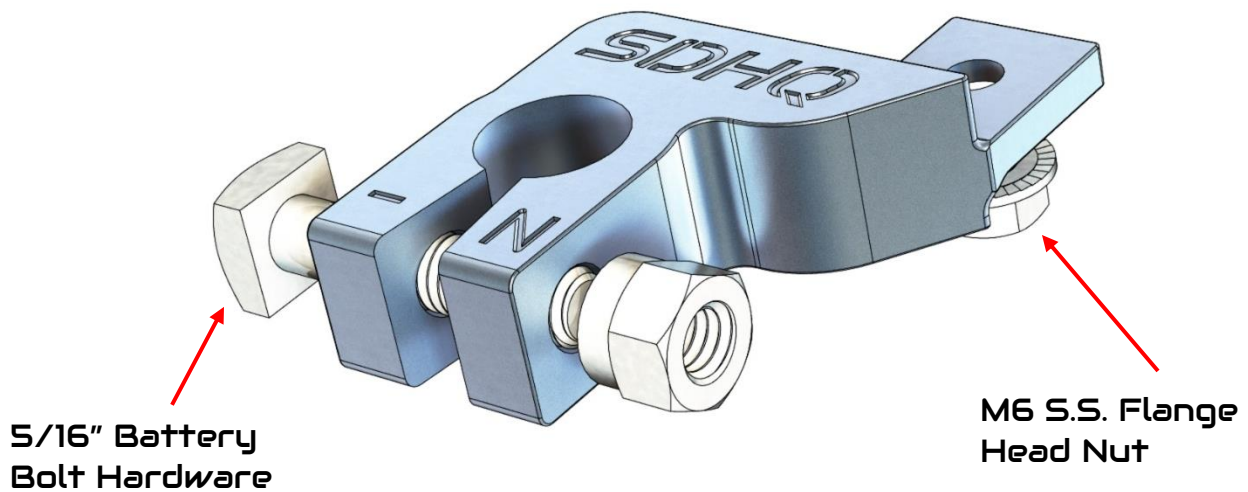

Installation Instructions:

1. Unbox your SDHQ Built Complete Billet Battery Terminal Kit and check over all parts. Familiarize yourself with the parts and diagrams above on Page 4. Shown to the right is the **Battery Sensor** this kit is designed for.
2. Disconnect the factory negative wires from the terminal sensor using a 10mm socket. Next remove the negative terminal from the battery using a 10mm socket. Remove the terminal from the terminal sensor using an E16 socket. Set the negative terminal aside to be replaced.



3. **Installing the Negative Terminals.** On the driver side start by removing the 13mm radiator support bolt shown in red and set it aside. Then remove the 10mm bolt holding the fan shroud to the radiator support shown in green. Grab your distribution block mount and attach it by loosely threading in the 13mm bolt removed previously. Place the provided black spacer between the mount and the radiator support. Replace the old 10mm bolt with the supplied M6 x 35mm. The bolt will be sitting outside of the mount.



4. Adjust the mount to a desired position and replace the 10mm bolt with the supplied S.S. M6 hex head and tighten. Thread the 13mm bolt in the rest of the way to lock the mount in place.



For questions or help with the installation, please email help@sdhqoffroad.com
Mon.–Fri. 8:00am–5:30pm and Sat. 8:00am–3:30pm Arizona Time. www.sdhqoffroad.com

- Next assemble your Billet Distribution Block using the provided hardware. Attach the 2 AWG negative wire to the block using the 3/8" eyelet. Using the M8 socket head bolt and flange head nut attach the block to the mount. Route the negative wire down under the engine side of the battery and positive wires to eventually come back up on the back side of the battery as shown.

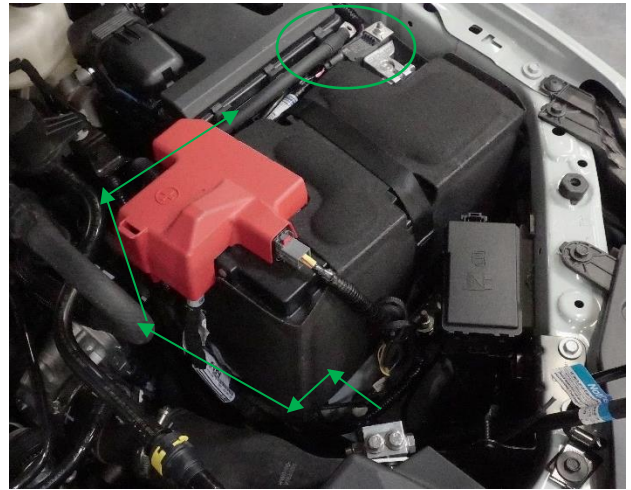

- Install the battery shoulder bolt to the billet terminal sensor (02-3003-TS1). Connect the billet sensor terminal using the supplied M6 stainless nut. Then install the sensor terminal on the negative stud placing a black terminal washer down first. Lightly tap on the top of the terminal using a rubber mallet to set it on the battery post. Tighten the 5/16" Battery Bolt and Nut using 1/2" wrenches on both to prevent damaging the battery post.



- Connect all negative wires to the negative terminal. Enjoy your new SDHQ Built Ford Ranger Complete Billet Battery Terminal and Distribution Kit!



For questions or help with the installation, please email help@sdhqoffroad.com
Mon.–Fri. 8:00am–5:30pm and Sat. 8:00am–3:30pm Arizona Time. www.sdhqoffroad.com

Torque Specifications

1. Torque the ¼” bolts to 4 ft-lb. Torque the 5/16” hardware to 8 ft-lb. Torque the 3/8” hardware to 18 ft-lb. Torque M8 – 1.25 x 30mm Socket Head Bolt to 16 ft-lb.

Double check all hardware is installed correctly and tight

Re-torque ALL bolts after 100 miles



190 S McQueen Rd
Ste 109 Gilbert, AZ 85233
www.sdhqoffroad.com

Follow us on:



Facebook



Instagram

For questions or help with the installation, please email help@sdhqoffroad.com
Mon.–Fri. 8:00am–5:30pm and Sat. 8:00am–3:30pm Arizona Time. www.sdhqoffroad.com