



SDHQ Motorsports
190 S McQueen Rd
Ste 109 Gilbert, AZ 85233

Product Packing List

Product: *SDHQ-14-1103-G6*

Description: **2021+ Ford Bronco ARB Air Compressor Mount**

_____ (1) ARB Compressor Mount	SDHQ-14-1103-G6-A
_____ (1) Fender Backer	SDHQ-14-1103-G6-B
_____ (1) Firewall Support Bracket	SDHQ-14-1103-G6-C
_____ (1) Hardware Package	SDHQ-14-1103-G6-HP
_____ (2) 3/8"-16 x 1-1/4" Grade 8 bolts	
_____ (2) 3/8" Grade 8 washers	
_____ (2) 3/8" Grade 8 split lock washers	
_____ (2) 3/8"-16 No-Slip Clip-on Barrel nuts	
_____ (3) 1/2" OD x 1/2" Long Nylon Spacer for 1/4" bolt	
_____ (3) M6-1.0 x 35mm S.S. Button Head	
_____ (10) M6 S.S. Washers	
_____ (3) M6-1.0 S.S. Nylock Nut	
_____ (4) M6-1.0 x 20mm class 10.9 Bolts	
_____ (4) M6 Split Lock Washers	
_____ (1) Straight 1/4" NPT Brass fitting (Male-Male)	
_____ (1) 90° 1/4" NPT Brass fitting (Female-Female)	
_____ (1) Industrial Quick Disconnect Air Hose Coupling (1/4" NPT)	

Inspected and Packaged By: _____ Date: _____

INSTALLATION INSTRUCTIONS

Product: SDHQ-14-1103-G6

Description: 2021+ Ford Bronco ARB Air Compressor Mount



<u>Parts List</u>	<u>Hardware List</u>	<u>Required Tools</u>
(1) ARB Compressor Mount SDHQ-14-1103-G6-A (1) Fender Backer SDHQ-14-1103-G6-B (1) Firewall Support Bracket SDHQ-14-1103-G6-C (1) Hardware Package SDHQ-14-1103-G6-HP	(2) 3/8"-16 x 1-1/4" Grade 8 bolts (2) 3/8" Grade 8 washers (2) 3/8" Grade 8 split lock washers (2) 3/8"-16 No-Slip Clip-on Barrel nuts (3) 1/2" OD x 1/2" Long Nylon Spacer for 1/4" bolt (3) M6-1.0 x 35mm S.S. Button Head (10) M6 S.S. Washers (3) M6-1.0 S.S. Nylock Nut (4) M6-1.0 x 20mm class 10.9 Bolts (4) M6 Split Lock Washers (1) Straight 1/4" NPT Brass fitting (Male-Male) (1) 90° 1/4" NPT Brass fitting (Female-Female) (1) Industrial Quick Disconnect Air Hose Coupling (1/4" NPT)	8mm, 10mm, 9/16" Socket Ratchet 3", 6" Extensions Wobble Adapter 9/16" Wrench 1.2 10mm ratcheting end wrench Small Phillips Screwdriver

Tech Notes

Use Thread Locker on all Stainless Steel (S.S.) Hardware.
 Read all ARB Compressor Instructions before beginning.
 Shown with ARB Twin Compressor, compatible with ARB Single Compressor as well.
 Fits both engine options for the Bronco
Approx. Install Time: 1 1/2 Hours (not including wiring)

READ ALL INSTRUCTIONS THOROUGHLY FROM START TO FINISH BEFORE BEGINNING INSTALLATION!

Mon.-Fri. 8:00am-5:30pm and Sat. 8:00am-3:30pm Arizona Time. www.sdhqoffroad.com

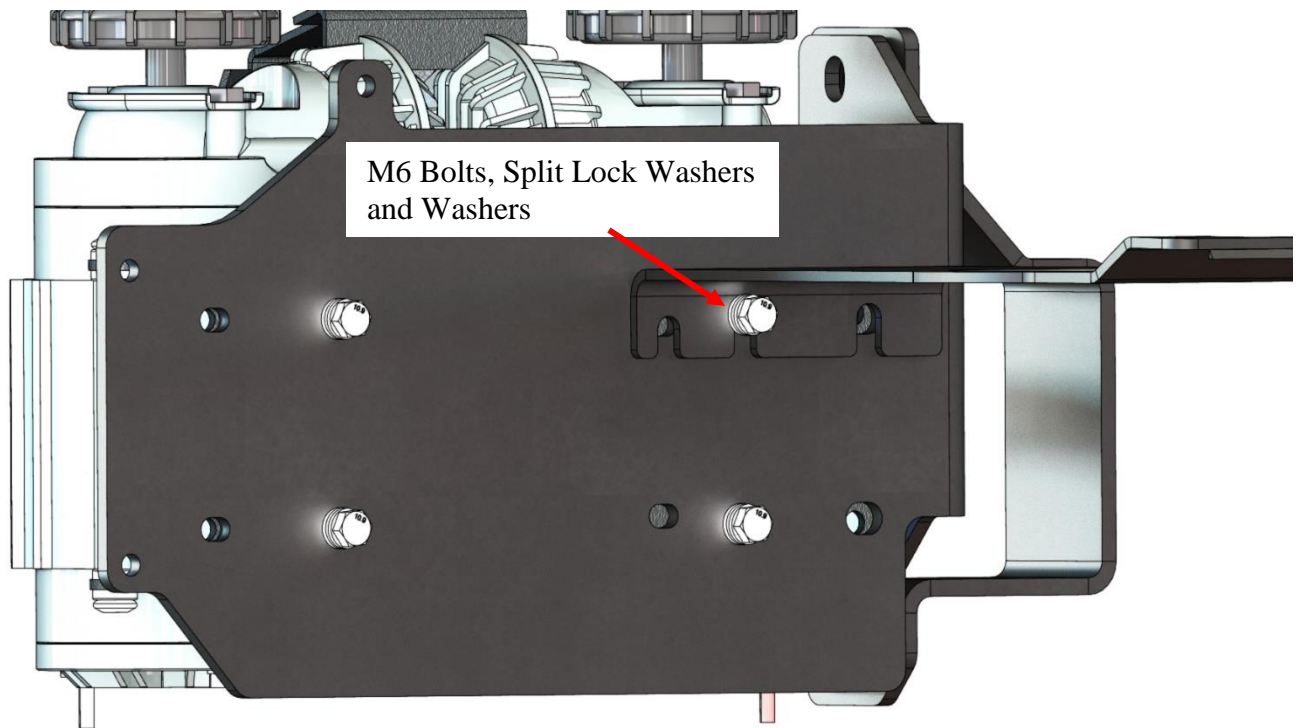
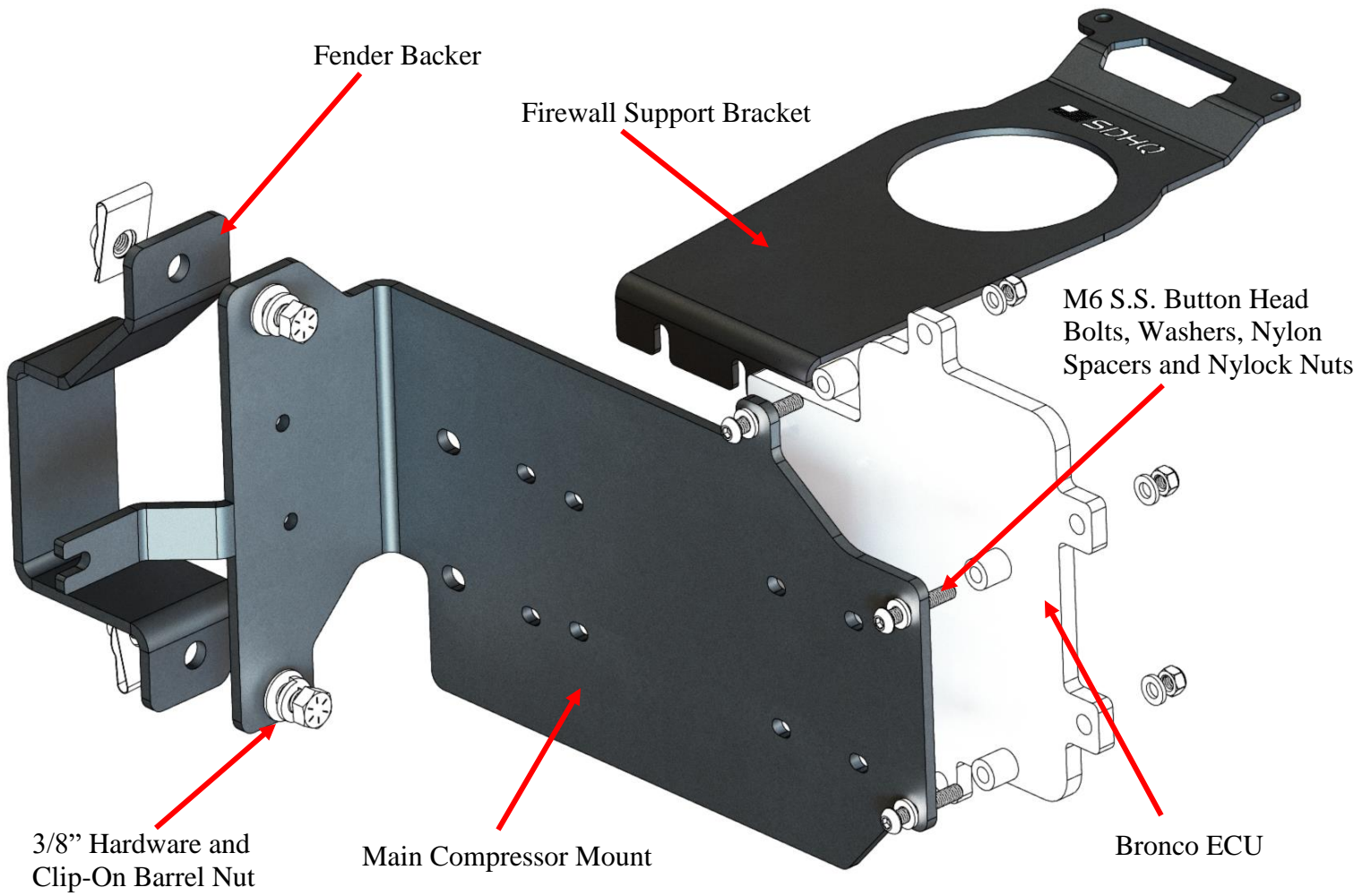

Installation Instructions:

1. Unbox your ARB Compressor Mount and verify all parts are present. Familiarize yourself with the diagrams on Page 4.
2. **Prepare your vehicle.** Start by removing the (3) 8mm bolts holding the ECU mount and the fender ground, then the (1) clip in the fender liner using a small screwdriver. Remove the (3) 10mm nuts holding the ECU to the mount. Discard the ECU mount, keep the (2) 8mm bolts that held the ECU mount to the fender for later.

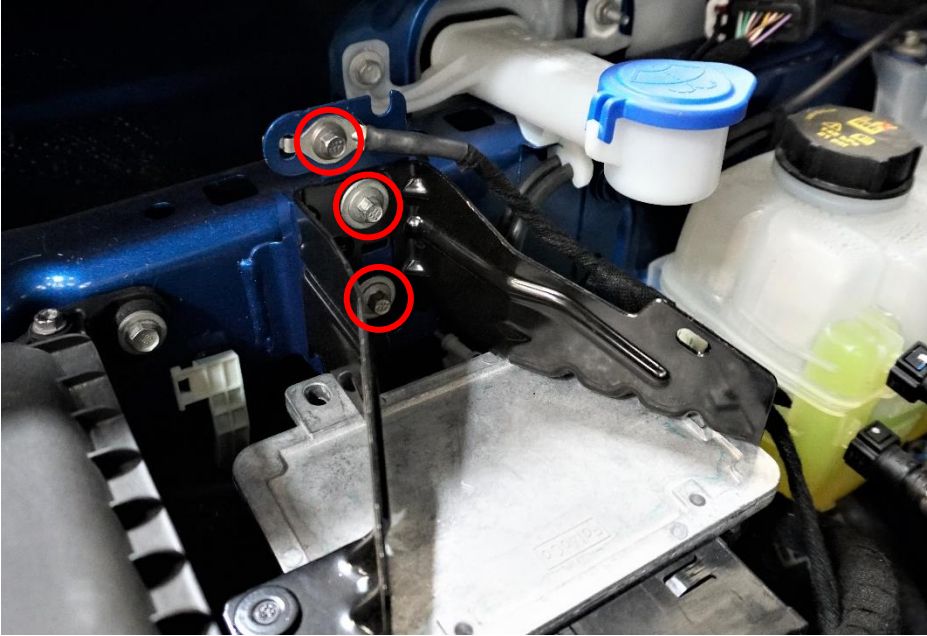

3. Loosen the 10mm bolt holding the airbox to the fender and place the Main Compressor Mount behind the airbox as shown. Then, use (2) of the 8mm bolts removed from the ECU mount and bolt them through the Main Compressor Mount to the fender as shown. Tighten all hardware.

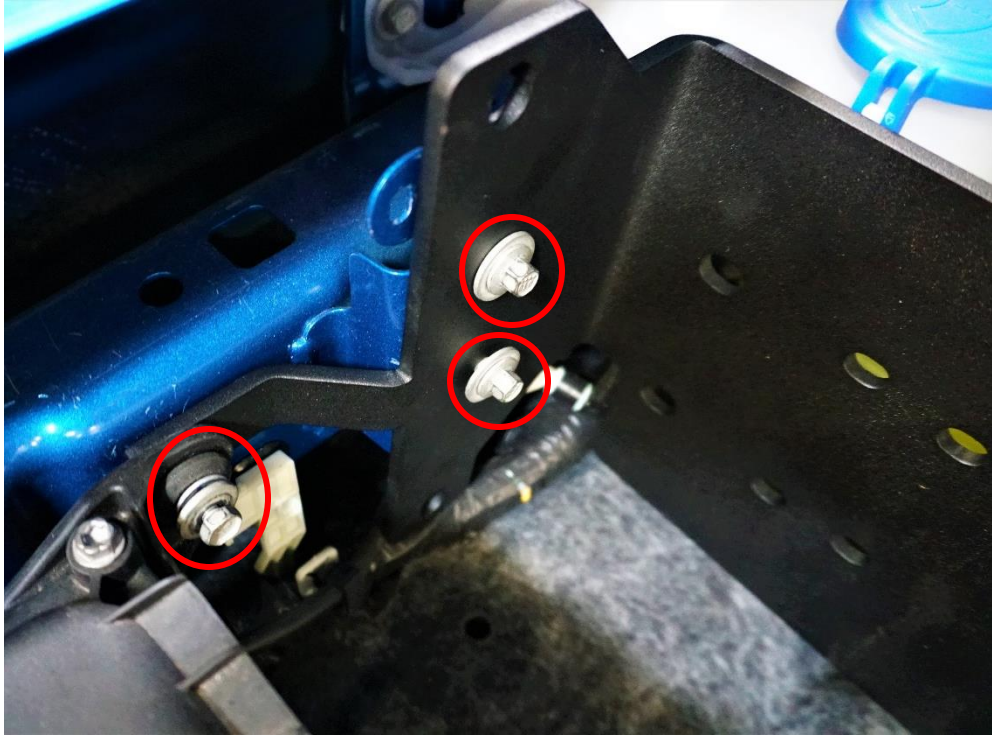

4. Prepare your Fender Backer by placing the (2) 3/8"-16 Clip-on Barrel nuts over the holes. Place the Fender Backer into the fender, with the notched end pointing down, from the top opening and align it with the slots in the Main Compressor Mount. Bolt the Fender Backer into place using the 3/8" bolts, washers and lock washers. When tightening, be sure to tighten the backer evenly so it sits flat on the frame and be careful not to pinch the wire harness or washer line near the fender liner.

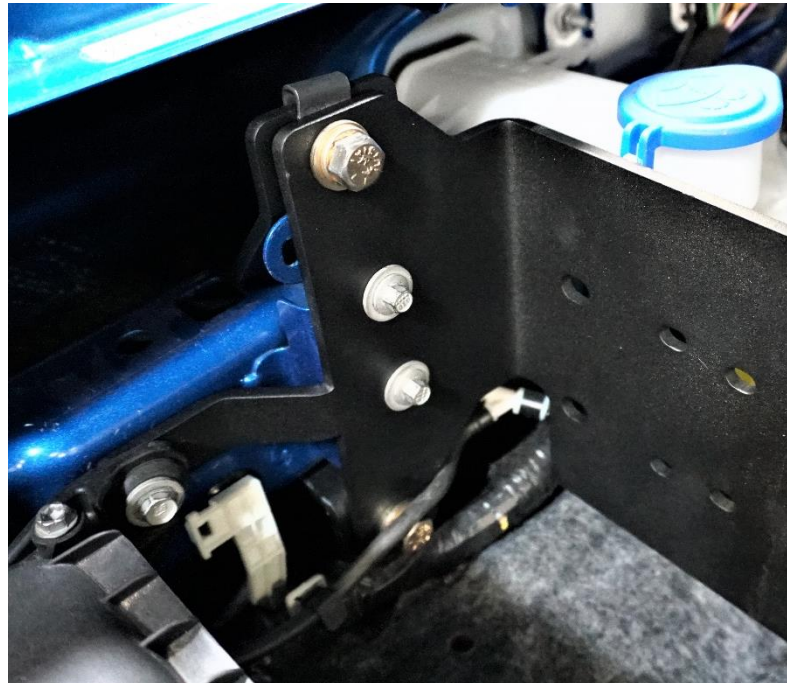
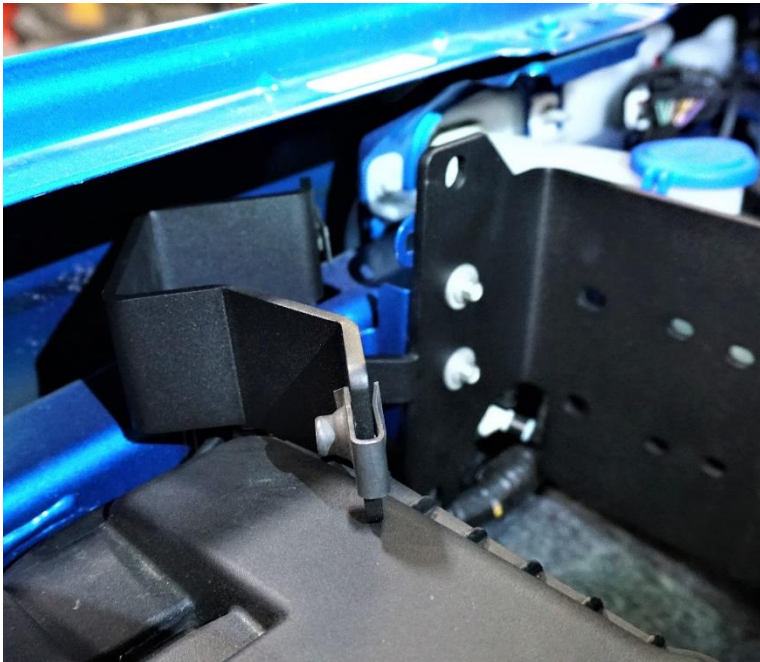

5. Remove the (2) 8mm bolts that hold the coolant reservoir to the firewall and place the Firewall Support Bracket over the reservoir and secure using the (2) 8mm bolts. Before tightening, be sure the bracket shows the upper row of slots as pictured.

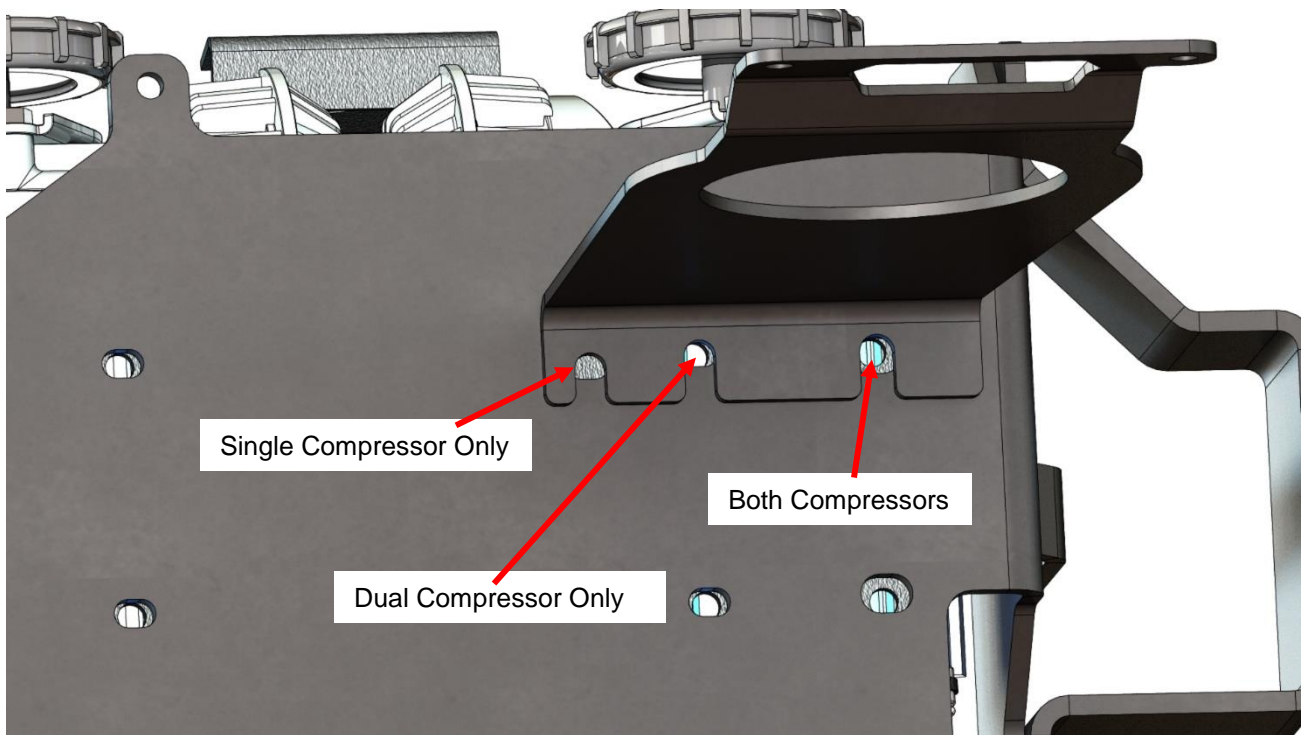
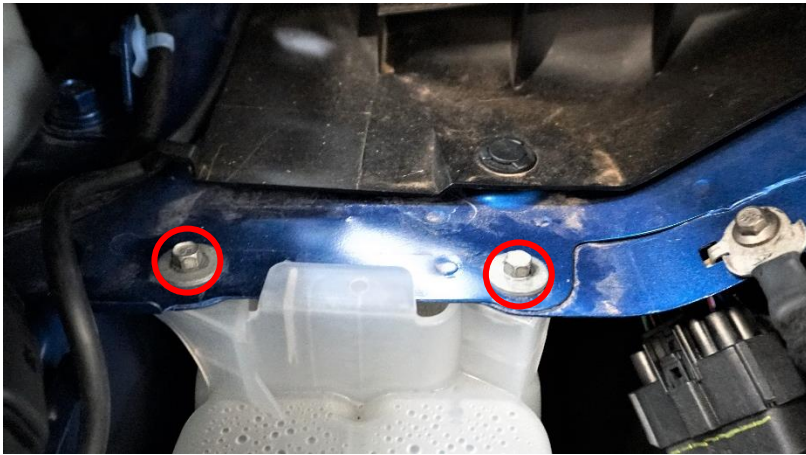

6. Now mount your compressor on the Main Compressor Mount using the ARB supplied M6 hardware on the outside (4) bolt holes and use the SDHQ supplied M6 x 20mm hardware on the inner (4) bolt holes (**Note:** This is for Dual Compressors only, for Single Compressors just use the ARB hardware). Use the previous diagram for which slots your compressor uses.

- Reinstall your ECU to the back of the Main Compressor Mount with the M6 x35mm S.S. Button head bolts, nuts, washers and nylon spacers as shown. When moving the ECU into place, be sure not to overly strain the wire harness, place the ECU against the spacers with the flat side of the ECU facing the mount, with the connector facing the fender.
- Connect the ECU ground at the existing ground on the firewall, remove the 8mm bolt holding the existing ground. Attach the ECU ground in the same spot and bend the terminal flat so there is less strain on the connection. See pictures for reference.

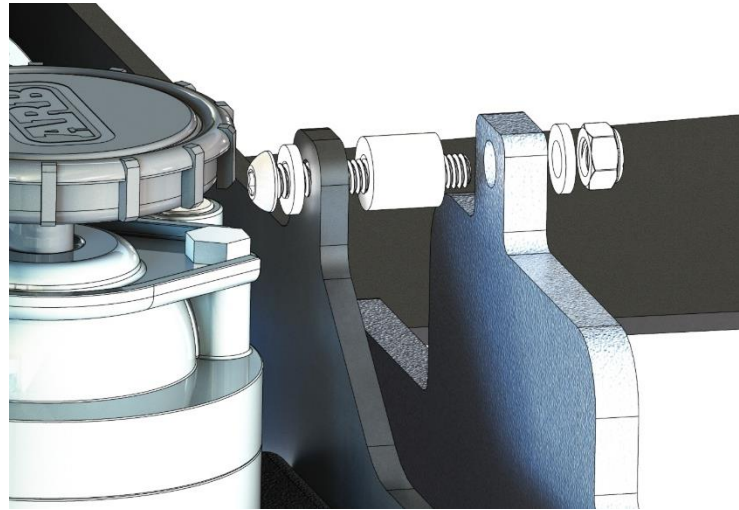

- Assemble the supplied quick disconnect air chuck pieces as shown below. Be sure to use PTFE tape on the threads of the adapters before assembling to help prevent any leaks. Then attach the assembly on to the air compressor.



- Finish your install by wiring your compressor. Enjoy your SDHQ Built ARB Air Compressor Mount for you 2021+ Ford Bronco!

*****Double check all hardware is installed correctly and tight*****

*****Re-torque ALL bolts after 100 miles*****



190 S McQueen Rd
Ste 109 Gilbert, AZ 85233
www.sdhqoffroad.com

Follow us on:



Facebook



Instagram

Mon.–Fri. 8:00am–5:30pm and Sat. 8:00am–3:30pm Arizona Time. www.sdhqoffroad.com

Page 9 of 9