



FACE-2-FACE Periscope Teleprompter USER MANUAL



Periscope Setup



Teleprompter Setup

For more information please visit our website: www.glidegear.net



FACE-2-FACE CONFIGURATIONS

The Face-2-Face Teleprompter can be used as:

- **A classic teleprompter:** look straight at the camera and read the text reflected on the beam splitter glass.

Use this configuration to get your classic news anchor shot.

- **A Periscope teleprompter:** look straight the camera while looking straight at the person talking to you.

Use this configuration to get a direct connection between the interviewee and the interviewer and achieve a very strong personal effect between the viewers and the person on screen.

Periscope Setup

- Compatible with any DSLR cameras.
- Adjust the distance between the beam splitter glass and the camera to accommodate most of the lenses.

For better results:

- Adjust the height of the camera to be leveled with the eyes of the interviewee.
- Mount LED light facing the interviewee and the interviewer on top of the teleprompter

Teleprompter Setup

- Compatible with any smart phones
- Compatible with tablet with a width no greater than 18 cm or 7"
- 3 m or 10 ft reading range
- Cover the camera with the supplied black cloth for a more visible reflection on the beam splitter glass.

WARNING: When the Face-2-Face is mounted on a tripod, we recommend using a tripod rated for a minimum capacity of 25 lbs or 12 kg



FACE-2-FACE ASSEMBLY

Prior to using the Face-2-Face Prompter, you will need to assemble the beam splitter glass on the main frame.

To do so:

- 1 Slide the beam splitter glass into the frame through the opening on the opposite side of the camera.

Warning: The beam splitter glass needs to be in the correct orientation. The yellow sticker on the glass frame needs to be facing the camera.

- 2 Use the 2 supplied thumb screws to lock the beam splitter glass in place to the top of the Face-2-Face.

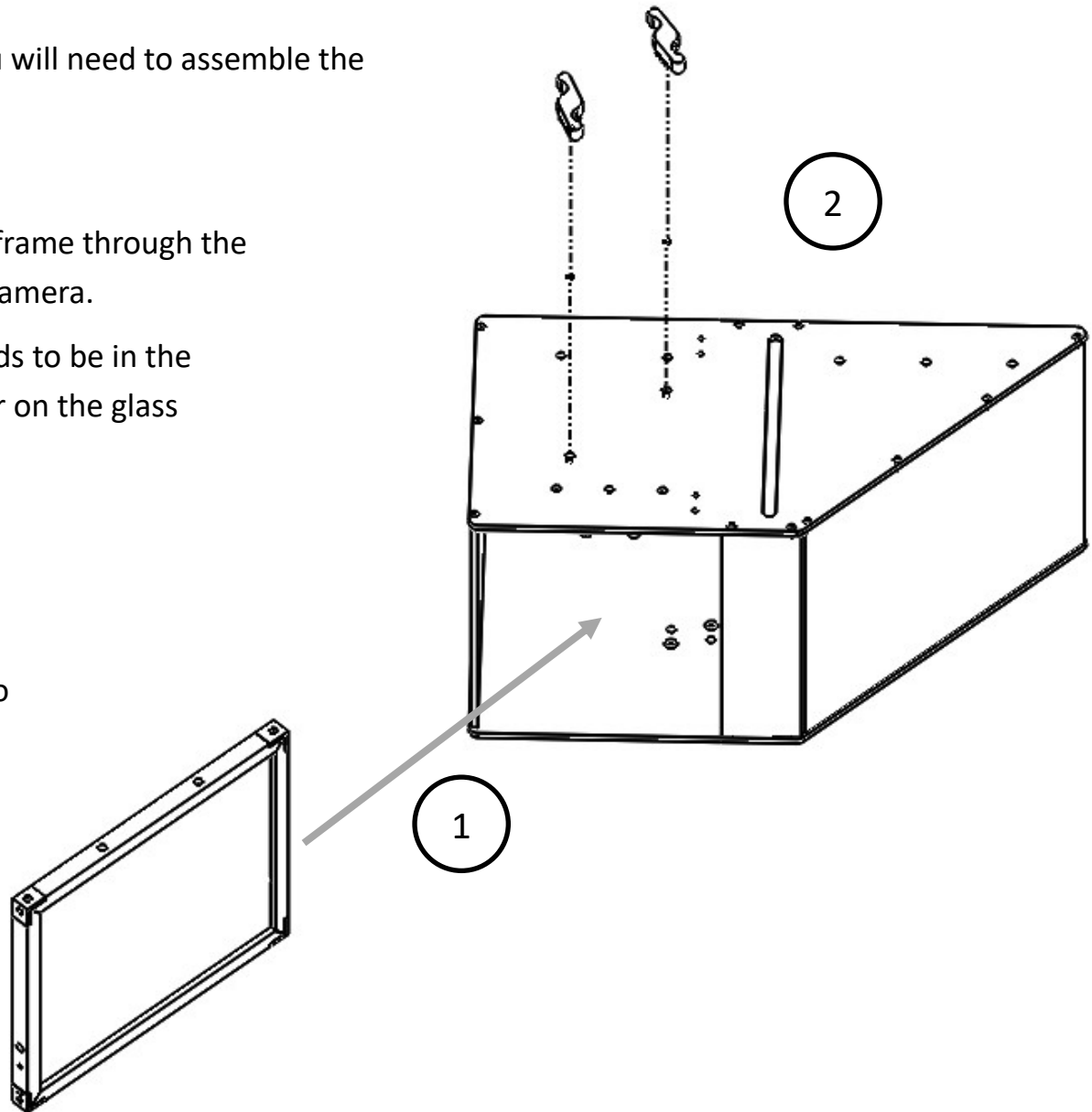



PERISCOPE CONFIGURATION

Overall Layout

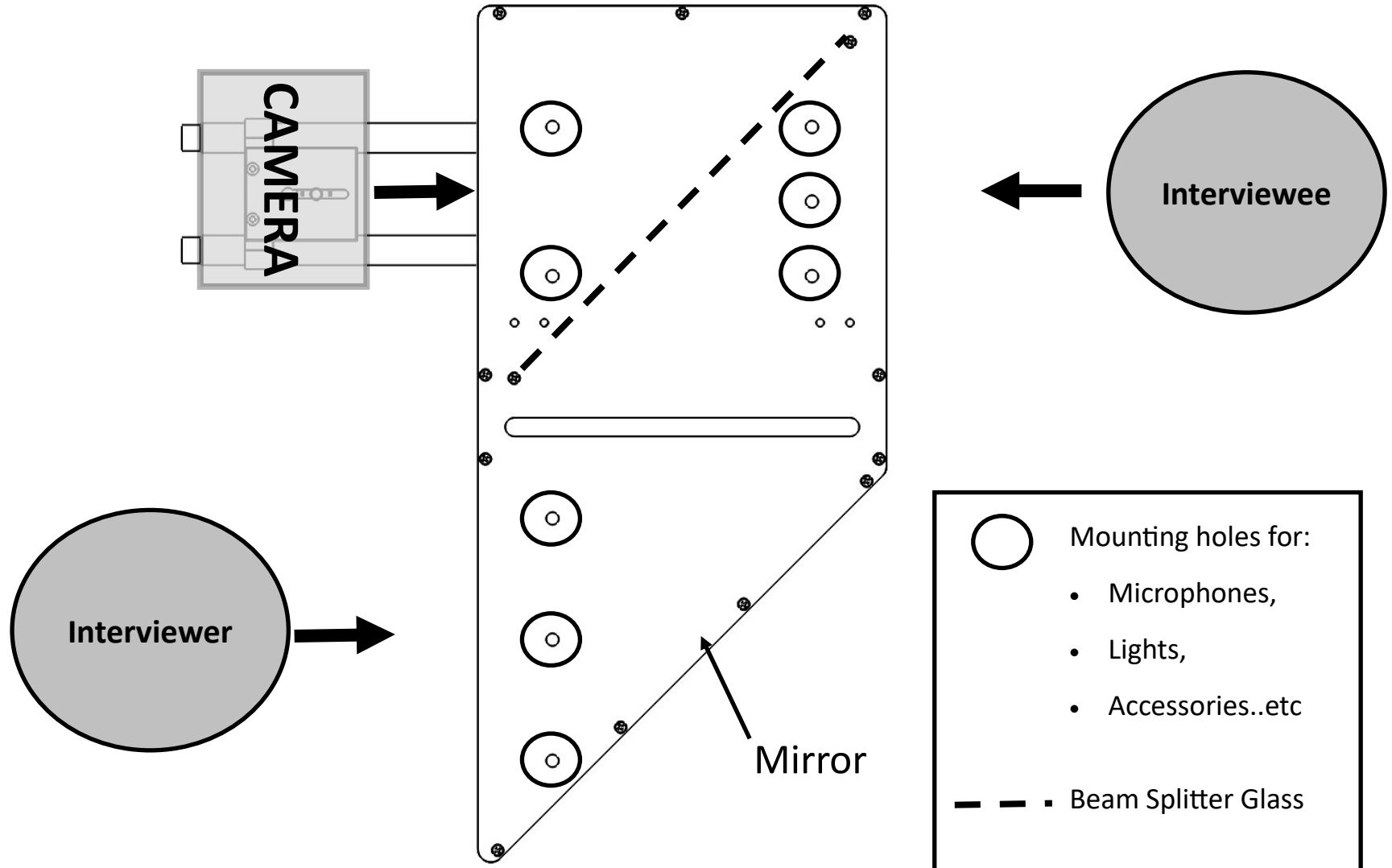



PERISCOPE CONFIGURATION

1

- Insert the rails into the clamp already mounted at the bottom of the teleprompter.
- Mount the riser onto the rails.
- Use the riser to move your camera back and forward.

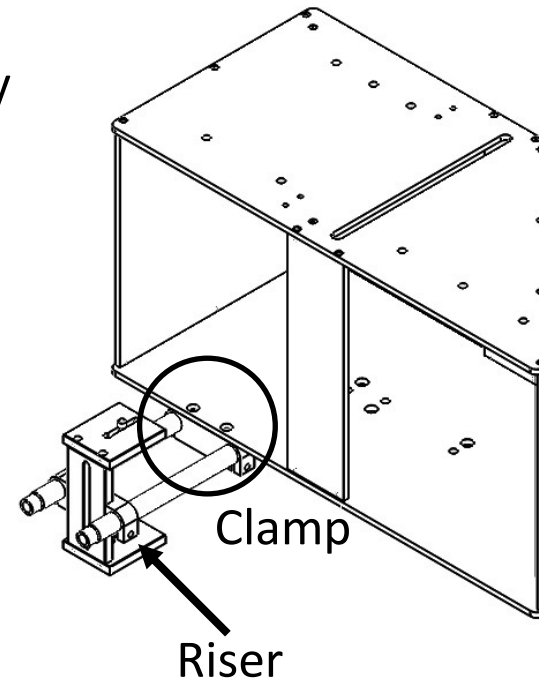

2

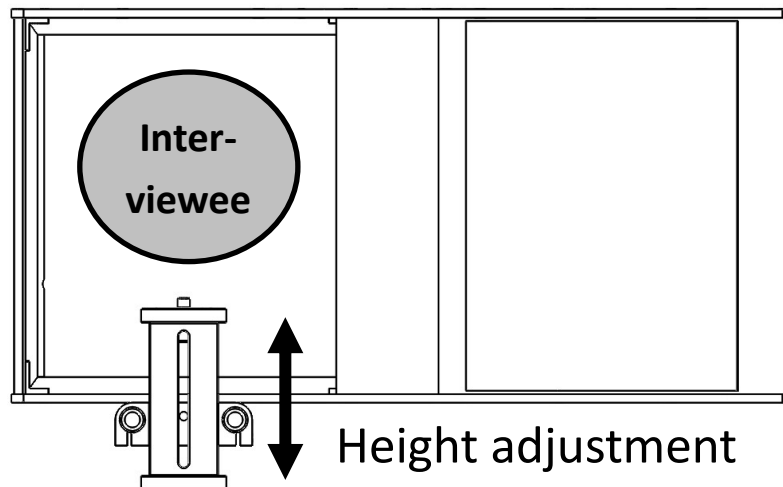

- Mount your camera onto the riser plate.
- Adjust the height of the rise so that your camera lens is aligned with the interviewee's eyes.



TELEPROMPTER CONFIGURATION

Overall Layout

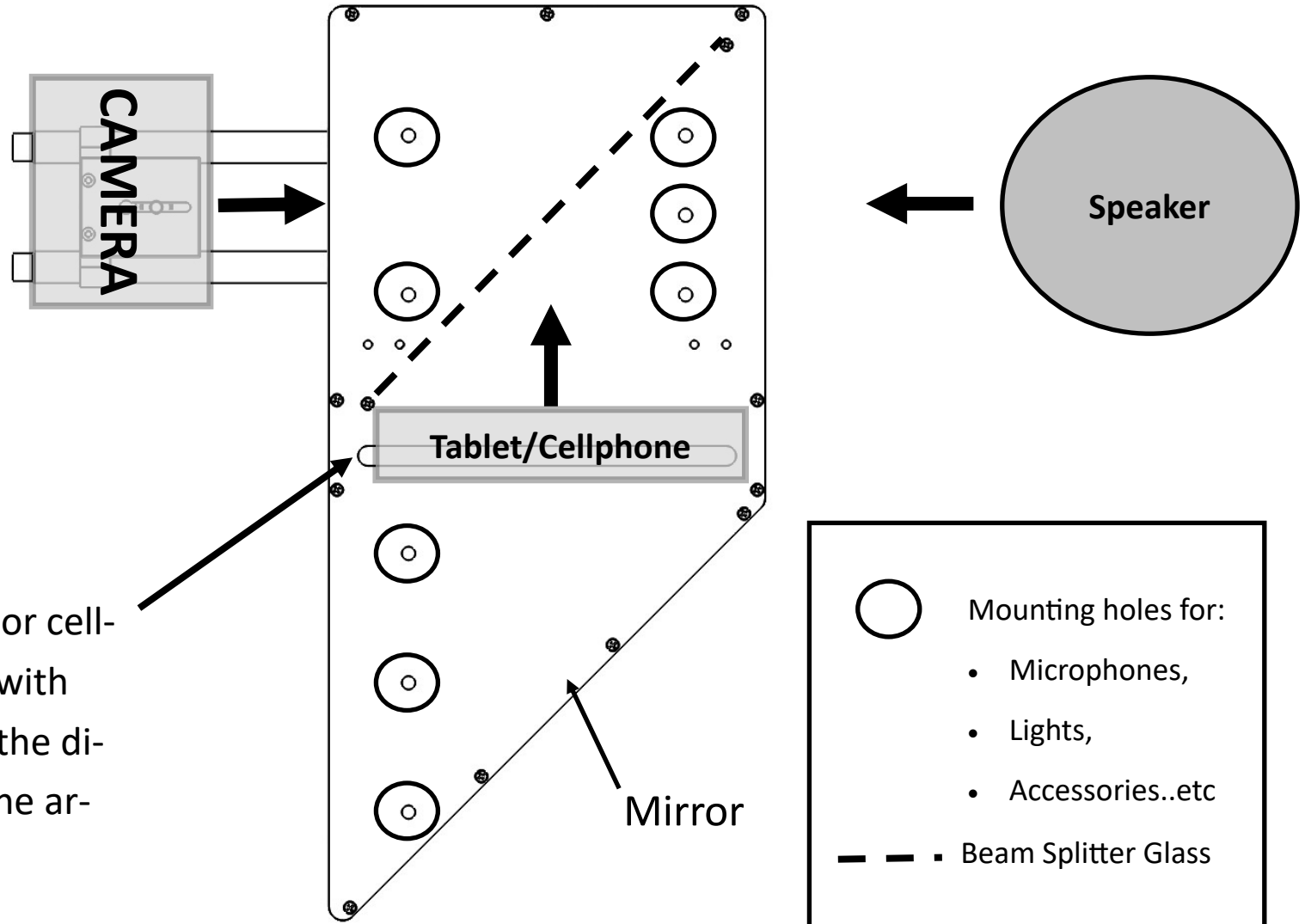



TELEPROMPTER CONFIGURATION

Cellphone

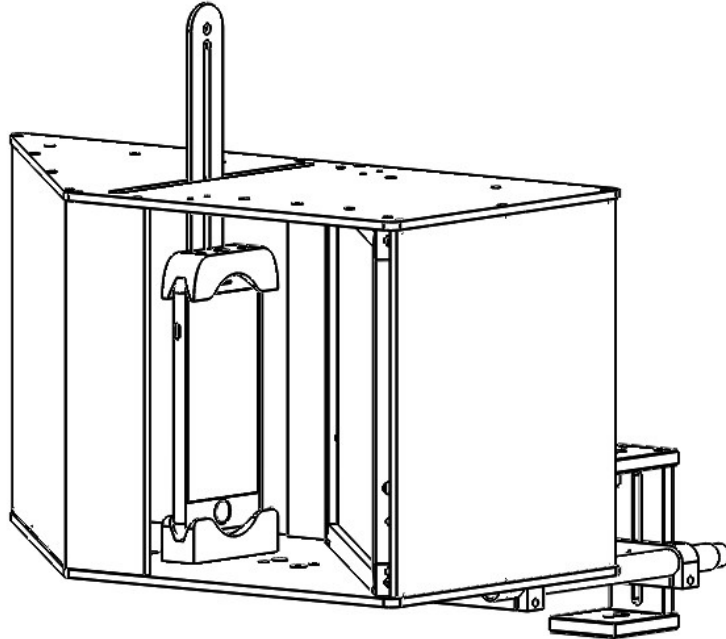

When using a cellphone:

- Place cellphone in a portrait or landscape orientation in the supplied holder.
- Insert the holder through the slot on the top of the teleprompter.
- The Phone must be facing the beam splitter glass.

Tablet

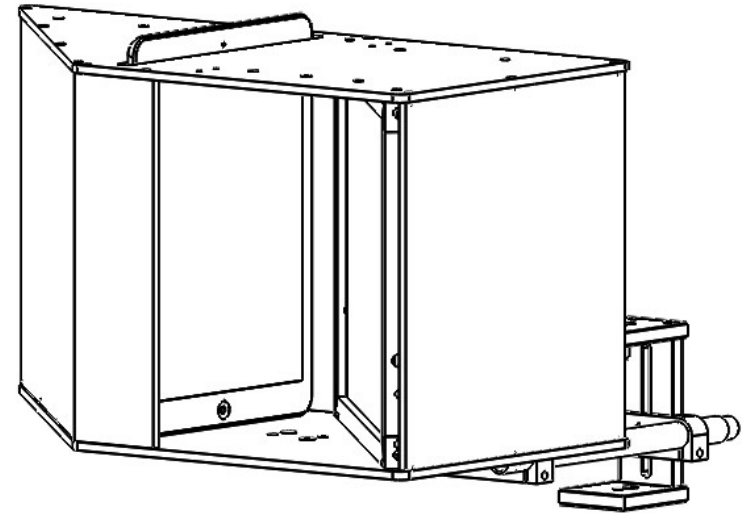

When using a tablet:

- Insert the tablet in a portrait through the slot on the top of the teleprompter.
- The tablet must be facing the beam splitter glass.