

PROTECTMAN

Advanced Security

User Guide Rodeoplus C4

INFORMATION

Rodeoplus is a type 6 device combining a belayer and a descender.

Manufactured by **PROTECTMAN**, 2 rue Maisant, 92190 Meudon – France, it is designed for climbing activities. His mission is to prevent the risk of free fall of the user, climbing on a climbing wall or a ladder type structure. **Rodeoplus** integrates a braking system and an automatic blocking loose pulley. **Rodeoplus** meets the following requirements : European PPE Regulation 2016/425 repealing PPE Directive 89/686/CEE and UE norm EN 15151-1 : 2012.

Tests have been conducted with dynamic rope, brand is BÉAL®, complying with EN 892 model is WALL SCHOOL Ø10,5mm.

Below is the notified body that conducted the tests :

APAVE SUDEUROPE SAS
17 Boulevard Paul Langevin
38600 Fontaine - FRANCE

Activities that require the use of this type of equipment are inherently dangerous. You are responsible for your own acts and decisions. Before using this equipment, a training is required and conducted by a competent person and/or qualified by the manufacturer.

Rodeoplus must not be used beyond its limits nor in any other situation than the ones the device has been intended to.

Installing and prior verifications of this equipment must be performed by a competent person and/or qualified by the manufacturer.

Rodeoplus must be used by a person with a good physical condition, competent person and/or qualified by the manufacturer, or placed under the direct surveillance of such person.

The whole installation must meet manufacturer's requirements and the following ones : European PPE Regulation 2016/425 repealing PPE Directive 89/686/CEE.

For the record, norms and regulations quoted in this guide make reference to their latest version presently effective.

INTENDED USE AND APPLICATION

Rodeoplus must be used by one person at a time, weighing 100 kilograms maximum, gear included, supervised by a belayer. During ascent, the belayer must take the rope in so that the strand of rope connecting the user to the **Rodeoplus** is taut at all times.

Rodeoplus must be used vertically exclusively, limiting pendular movements.

Movements of the user are prohibited above the device. Their are also limited to an angle of 30° on each side with respect to a vertical axis.

Rodeoplus must be used exclusively with :

- dynamic rope, diameter from Ø10,5mm, complying with norm EN 892 (tolerance in rope diameter up to ±0,2mm). Diameter and other characteristics may change according to use. Beware, mechanical properties of the rope change according to its state, humidity, wet, freeze, etc.
- anchorage with minimum resistance of 1500 DAN,
- a connector complying with EN 12275 to connect the device to anchorage,
- a connector complying with EN 12275 to connect the rope to the harness,
- a harness complying with EN 12277.

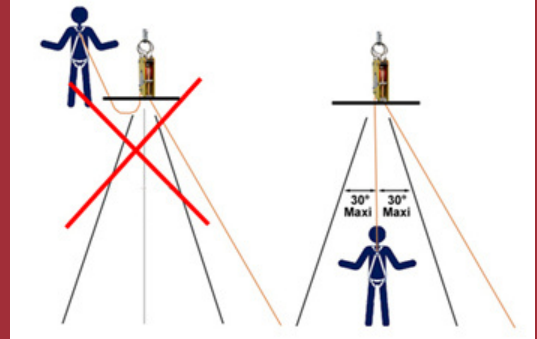

Personal protection equipments used in addition must be referenced "CE" for Europe and compatibles between them. Read carefully the user guide of each product. If doubts remain on how to use a product, do not use and ask advice to a qualified person or manufacturer.

IMPORTANT : You must comply with the rules of this user guide. A training is required for the user before using the device, read user guide and all other attached documents, or seek help of a qualified person to explain. User must act the same with the rest of the equipment, harness, rope, carabiners and their user guide.

ROPE INSTALLATION

Installation of the rope in the device is simple :

See the engraved diagram on the device for a proper rope installation.

Facing the device with markings, slide the rope in from under on the right side of the device between spacer (1) and the core (2), slide the rope at the bottom of the groove of the pulley (picture 1).

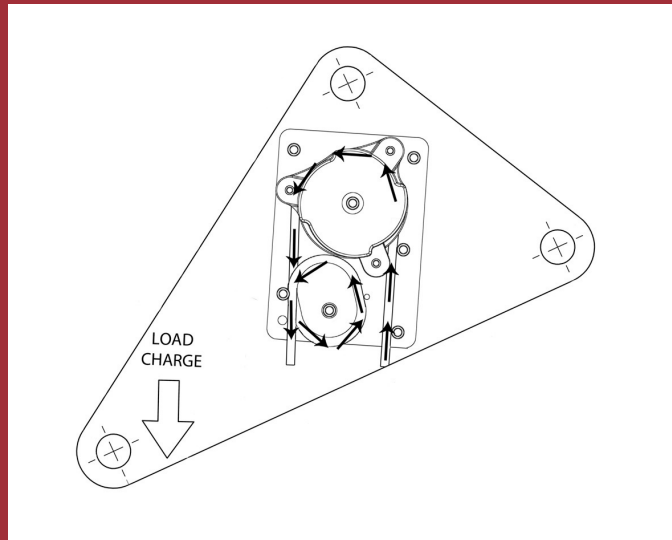

Ensure the rope is well set in the groove of the pulley.

Slide the rope out on the left side of the device and pull it downwards, between spacers (3) and (4) and cam roller (5) (picture 2).

Wind the rope onto the cam roller (5) ONE SPIN (1 x) and slide it out between spacer (3) and (4) an cam roller (5), over the rope on left side of cam roller (5) (picture 3).

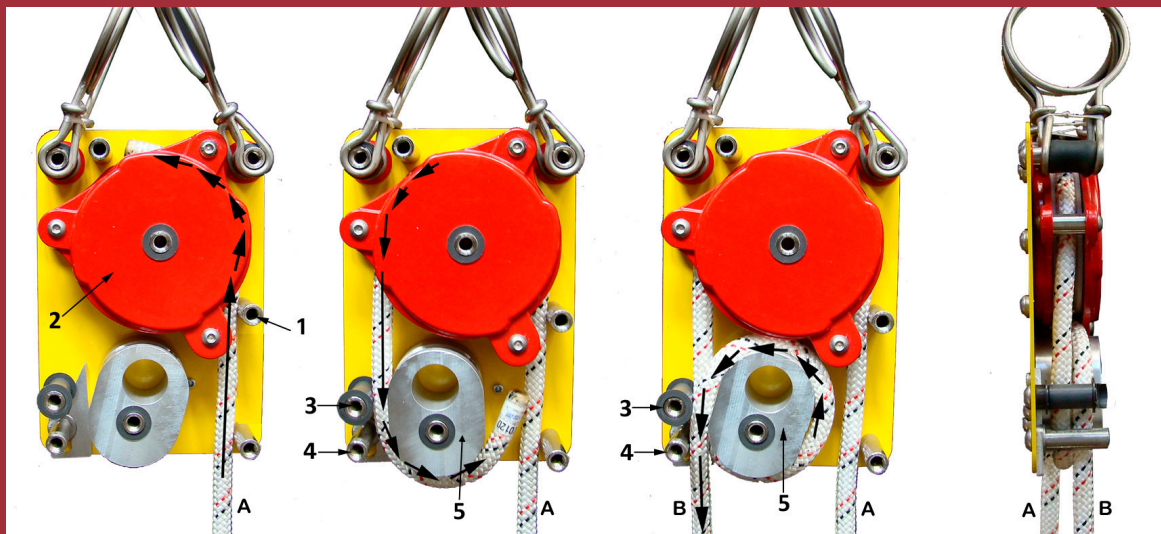

Picture 1

Picture 2

Picture 3

Picture 4

ROPE INSTALLATION - Suite

After rope installation, tie an « 8 » knot (see picture below) on end of the rope (B) climber strand « LOAD/CHARGE ». Tie a stopper knot to secure the « 8 » knot.

« 8 » Knot

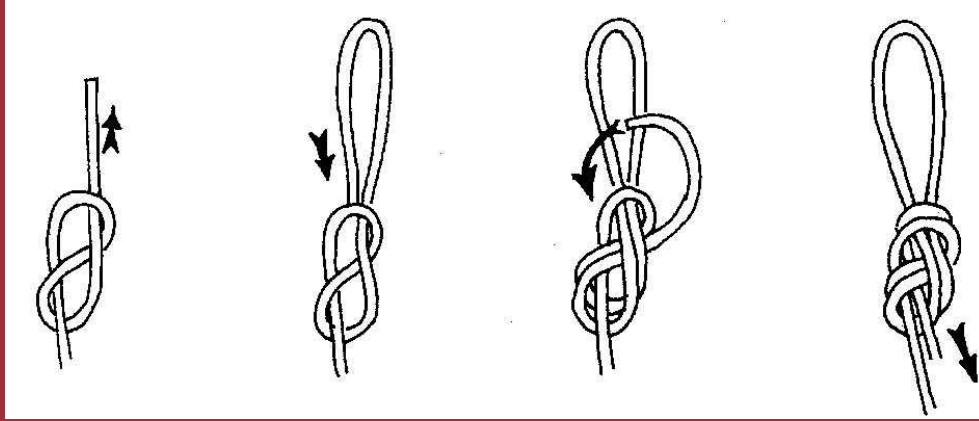

Tie a stopper knot on the other end of the rope (A) belayer strand (see picture below). This strand can be handled with a traditional belay and abseil device.

Stopper knot

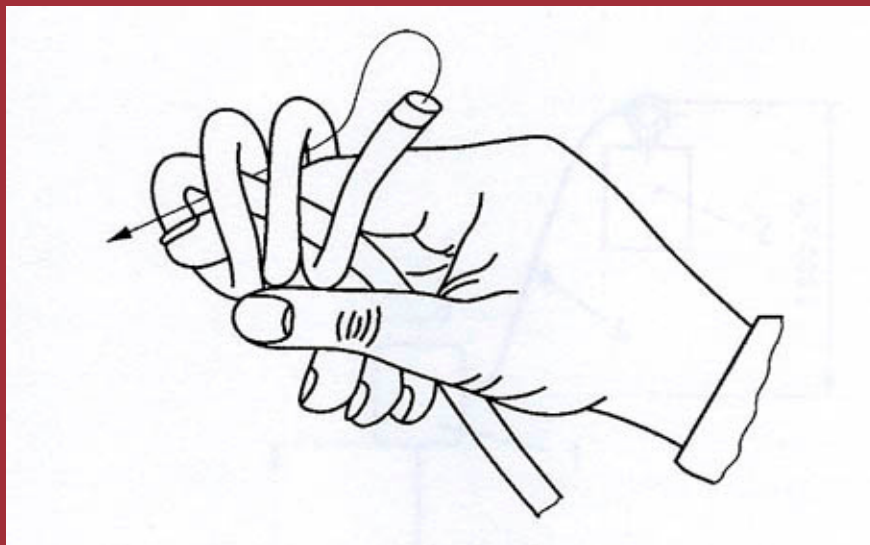

TEST & VERIFICATION

Rodeoplus must imperatively be checked before every use. Check if the rope is properly installed by pulling quickly downwards on strand (B), with « 8 » knot and « LOAD/CHARGE » side of the device (climber side, engraved on frame). Device must lock and let you hear a « klik ».

Climber must connect only on « 8 » knot, climber strand « LOAD/CHARGE », other connecting is absolutely forbidden and may cause accidents or even death.

USE

Before use, proceed to a visual control of the device. There must not have cracks or deformations, or foreign object in it. All screws must be present and tightened.

Rodeoplus must be connected to anchorage thanks to its two shock absorbers on top, using EN 12275 complying connectors. Anchorage on one shock absorber is FORBIDDEN. Minimum resistance of anchorage must be 1500 DAN. **Rodeoplus** can be anchored on a hanger arm which minimum resistance is 1500 DAN.

Install rope in **Rodeoplus** as stated in previous chapter. Install the **Rodeoplus** climber side, « LOAD/CHARGE » engraved, against the wall.

The EN 12277 complying harness of the climber must be connected to the 8 knot of the rope with a EN 12275 complying connector.

Belayer have to check his ability to handle the weight of the climber before use.

The belayer continuously handle the belayer strand of the rope as climber strand must be taut at all times when ascending or descending. Belayer must take the slack of the rope in on climber side and control the descent. Stopper knot at the end of belayer strand will prevent the rope to slip through the **Rodeoplus**.

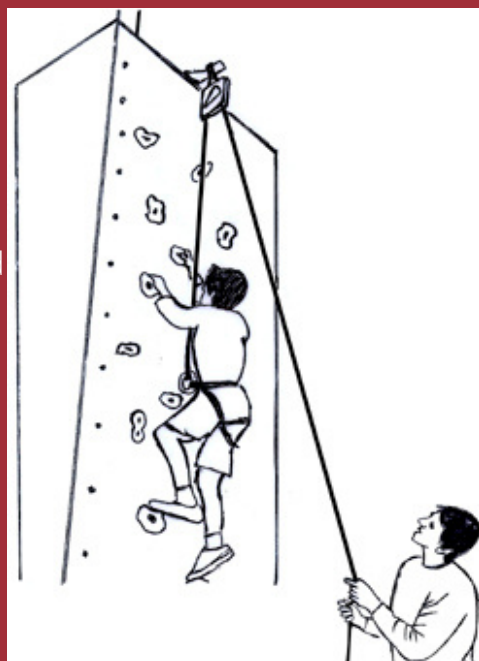

USE - Suite

Belayer strand can be handled with hand only or with a traditional belay and abseil device.

Climber must sit in the harness for descent, legs pushing on the climbing wall to keep distance. At this moment, belayer can begin the descent, letting the rope go one hand after the other to control the speed of the descent. Gloves are recommended despite the automatic blocking system of the **Rodeoplus** in case of fall or fast descent, there is a burning risk.

When ascending or descending, the device locks automatically in case of a fall, preventing the fall of the user. To unlock the device, user must ascend slightly and belayer keeping the climber tight. After unlocking the **Rodeoplus**, user can continue his ascent or descent.

We draw your attention on the fact that braking effect relies on a lot of different factors, such as type and wear of the rope or the weather. User is responsible for getting to know the braking effect available before use. For example, a brand new rope slips more. Braking increases with diameter of the rope. Braking increases with humidity of the rope and air.

When in use, **Rodeoplus** must be protected from impacts, sand, dust, vibrations and the contact of other objects. After every use, check wear of each part of the Personal Protection Equipment. Rope must be free of fraying, wear, rip in sheath. Metal parts must be free of oxidation or deformations.

CYCLE OF THE DEVICE

The durability of the device is difficult to determine as it depends of the use and maintenance of the equipment. Standard cycle as described in this user guide is 5 years. Cycle of the product can be extended depending of the results of the periodic maintenance performed by the manufacturer.

STORAGE

When storing **Rodeoplus** avoid impacts, vibrations, ultraviolet radiation, sand and dust, biological contamination.

Bad storing leads to early wear of the device.

Rodeoplus will be hanged with a carabiner in a dry, ventilated, cool area, avoiding chemicals, heat sources. Never store on the floor itself.

CLEANING & TRANSPORT

Never oil or grease **Rodeoplus**.

Never use pressurised air or water to clean the device. A soft brush must be used for cleaning. Water and neutral detergent can be used. Use a non-abrasive cloth to wipe in case of wiping and let dry in a dry, cool and ventilated area avoiding chemicals, heat, radiation, etc.

Avoid water stagnation in the device by hanging it.

When carrying, protect it from any danger that can damage its performances and resistance. Protect the device from impacts, sand, dust, vibrations, contact with other objects and use an appropriate container, never in bulk.

CONTROL & MAINTENANCE

Rodeoplus requires a consistent maintenance. Keeping it clean guarantees its durability.

It is important to frequently check the device when operating. Stop using it if you find some damages, chemical aggression or defaults. In that case, contact the manufacturer.

Every **Rodeoplus** must be put out of order immediately if you have doubts about safety.

When the device shows damages or signs of malfunctioning, put it out of order immediately, marking it and returning it to the manufacturer or an authorized service center for a refurbish. Refurbish will be authorized with written agreement only.

For security reasons, refurbish must be performed only by the manufacturer or a service center authorized by **PROTECTMAN**. **Dismantling and modifying the Rodeoplus are strictly forbidden**. Repairing, dismantling or modifying the **Rodeoplus** by persons non-authorized by **PROTECTMAN** automatically cancels the warranty.

Rodeoplus must be controlled every 12 month by the manufacturer or a service center authorized by **PROTECTMAN**, periodic maintenance is mandatory. In case of intensive use **Rodeoplus**, user must decide by himself of the intervals of maintenance, which cannot exceeds 12 months.

Every 5 years, **Rodeoplus** is refurbished or changed according to wear.

When controlled, **Rodeoplus** is dismantled, parts cleaned or replaced, then reassembled and tested as brand new.

Beware: Authorized service centers are responsible for their own work. **PROTECTMAN** cannot be held responsible for the work done by others.

WARRANTY

Warranty covers manufacturing defects for a period of 12 months after the delivery date. Warranty does not apply if an impact caused by a fall or if parts are modified, replaced or repaired outside the premises of **PROTECTMAN**, or if the device is not used as described in this user guide.

Warranty does not cover : normal wear, modifications or adjustments, inappropriate storage, inappropriate maintenance, damages caused by accidents or carelessness, incorrect use of **Rodeoplus**.

Responsability : **PROTECTMAN** cannot be held responsible for direct, indirect, accidental consequences or for any other kind of damage caused by an incorrect use of his products.

INFORMATION ON MARKINGS

Marking is laser engraved on front stainless steel metal plate :

- Model : **Rodeoplus**
- REF. C4 : reference number
- Serial number « xxxxx »
- Identification of manufacturer (name and address of manufacturer) :

PROTECTMAN

Email : rodeostop@gmail.com

Tél. : +33 1 45 34 52 05

www.protectman.net

- pictogram of a book with the letter « i » : read user guide before use
- months and years : hallmark indicates manufacturing and maintenance dates
- CE : complying with PPE Directive 89/686/CEE
- 0082 : identification number of the notified body responsible for fabrication control (article 11A) and CE type tests :

APAVE SUD EUROPE SAS

CS60193

13322 MARSEILLE CEDEX 16 - FRANCE

- EN 15151-1 : complying with european norm EN 15151-1 : 2012
- pictogram « 1 max 100 Kg » meaning one user at a time weighing a maximum of 100 kilograms
- type and diameter of rope : dynamic rope diameter \varnothing 10,5mm complying EN 892.

CE CONFORMITY

User guide and certificate of conformity can be downloaded at www.protectman.net

Find more on
www.protectman.net