

CARME-208SPW

Dual 8" Powered Subwoofer

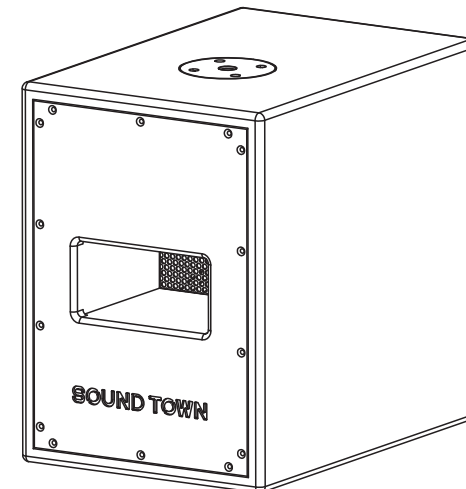

IMPORTANT SAFETY INSTRUCTIONS

1. Read all safety and operating instructions before using this product.
2. All safety and operating instructions should be kept for future reference.
3. Read and understand all warnings listed on the operating instructions.
4. Follow all operating instructions to operate this product.
5. This product should not be used near water, i.e. Bath tub, sink, swimming pool, web basement etc.
6. Only use dry cloth to clean this product.
7. Do not block any ventilation openings, it should not be placed flat against a wall or placed in a built-in enclosure that will impede the flow of cooling air.
8. Do not install this product near any heat sources, such as, radiators, heat registers, stove or other apparatus (including heat producing amplifiers) that produce heat.
9. Do not defeat the safety purpose of the polarized or grounding-type plug. A polarized plug has two blades with one wider than the other. A grounding-type plug has two blades and a third grounding prong. The side blade or the third prong are provided for your safety if the provided plug does not fit into your outlet, consult an electrician for replacement of the obsolete outlet.
10. Protect the power cord being walked on or pinched particularly at Plugs, convenience receptacles and the point where they exit from the apparatus. Do not break the ground pin of the power supply cord.
11. Only use attachments specified by the manufacturer.
12. Use only the cart, stand, tripod, bracket, or table specified by the manufacturer or sold with the apparatus. When a cart is used use caution when moving cart/apparatus combination to avoid injury from tip-over.
13. Unplug this apparatus during lightning storms or when unused for long periods of time.
14. Care should be taken so that objects do not fall and liquids are not spilled into the unit through the ventilation ports or any other openings.
15. Refer all servicing to qualified service personnel. Servicing is required when the apparatus has been damaged in any way; such as, power-supply cord or plug is damaged, liquid has been spilled or objects have fallen into the apparatus, the apparatus has been exposed to rain or moisture, does not operate normally or has been dropped.
16. **WARNING:** To reduce the risk of fire or electric shock, do not expose this apparatus to rain or moisture.
17. When the MAINS plug, or an appliance coupler is used as the disconnect device, the disconnect device should remain readily operable.
18. Protective Ground Terminal: The apparatus shall be connected to an AC main socket with a protective earth ground connection.



FEATURES

- The SOUND TOWN CARME series powered subwoofer has a built-in high efficient Class-D amplifier provide various of input connector such as 1/4" / XLR combo and RCA.
- Passthrough XLR line output provides the flexibility of connecting other apparatus.
- LPF (Low Pass Filter) allows to adjust the frequency filter from 40~150Hz.
- Folded horn design with customized low frequency driver provides powerful and strong bass while takes small footprint.

In the package

- 1 CARME subwoofer
- 1 User Manual
- 1 Power cable
- 1 Warranty Card

How can we help you?

CONTACT OUR US-BASED SUPPORT TEAM

Simple or complex, your questions are important to us. For service, support or more information, please contact the Sound Town support team:

Email: support@soundtown.com

Rear Panel Instruction

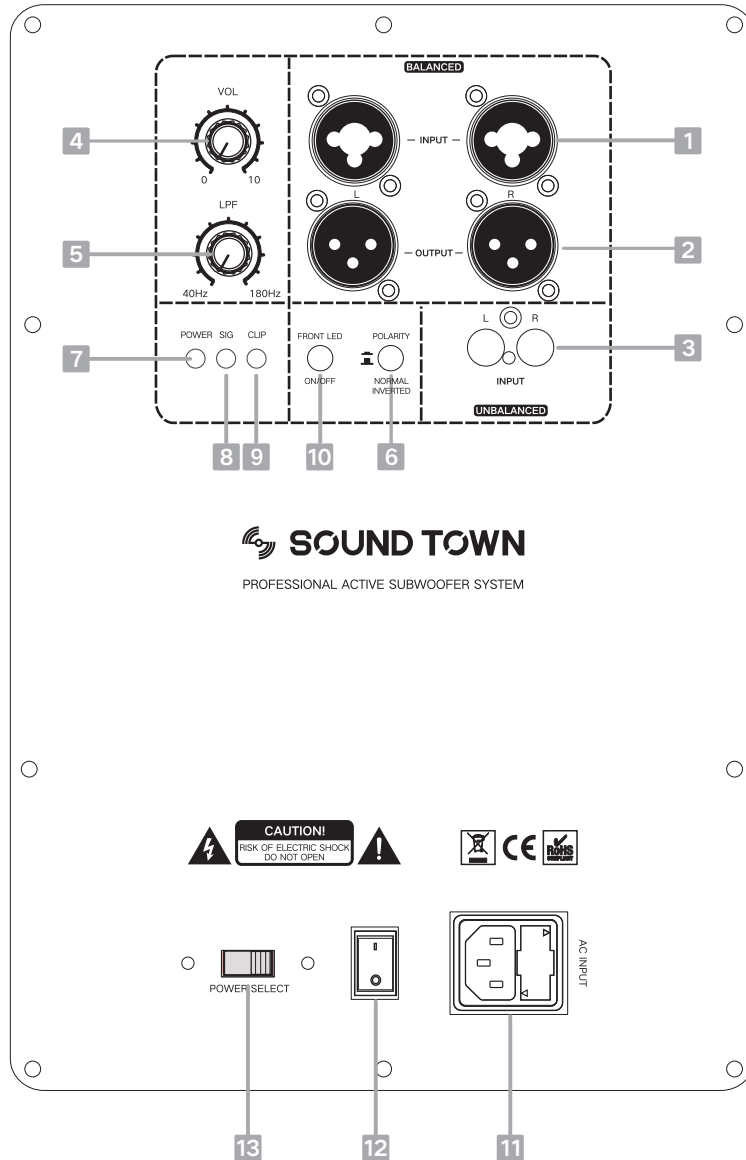

1. Combo Input: Two balanced 1/4"/XLR combo jack A/B are provided. This allows for stereo input from two separate feeds. The subwoofer will work with only one input connected.

2. XLR Output: Two XLR full-range passthrough output are provided. These outputs are not affected by the LPF and will send full-range signal on the rest of your PA setup.

3. RCA Input: Two RCA unbalanced input are provided. The subwoofer will work with only one input connected.

4. Volume Control: This controls the gain of the input signal. It will raise and lower volume of the subwoofer. Standard usage is setting this control at 50%.

5. LPF Control: Low Pass Filter, this controls how much high frequency is filtered out of the signal and how much of the higher bass frequencies are left in the signal. This does not add bass to the signal, it determines how much high frequency is cut out of the signal. Setting this control to the middle usually works best.

6. Polarity: This control will reverse the phase of the speaker in relation to the rest of the PA. This allows a quick fix for an out-of-phase setup.

7. Power LED: This indicator will light when the subwoofer is turned on.

8. Signal LED: This indicator will flash when there is signal input.

9. Clip LED: This indicator lights up when the amplifier is near clipping. An occasional flickering is acceptable. If LED is lit continuously, adjust the level control and reduce the output level of connected sources. Failure to do so may lead to premature failure of your speaker.

10. Front LED control: On/Off

11. IEC input: This receptacle is for connecting the included IEC power cable. It is important to supply the proper AC line voltage to the unit. Do not connect to intermittent or faulty power.

12. Power Switch: To turn on/off the subwoofer.

13. Voltage selection: This switch is supplied for moving the unit from 115 voltage (US Standard) to 230 voltage (European Standard). The switch needs to be set on the proper voltage for your area.