

MTB HOPPER

USER MANUAL

The land is designed for **MTB and BMX** bikes.



Always wear your helmet.

It is recommended to wear knee pads, gloves and other safety equipment.



MTB HOPPER is designed for longevity, to withstand any weather and provide good grip with tires. We recommend to store it in a **dry place**.

Use it responsibly.

Go through all the steps before riding to ensure safety. If you have the opportunity, train together with more experienced riders. Good luck at improving your riding skills!

3 PHASES OF JUMP

FIRST PHASE

NEUTRAL stance in the acceleration zone

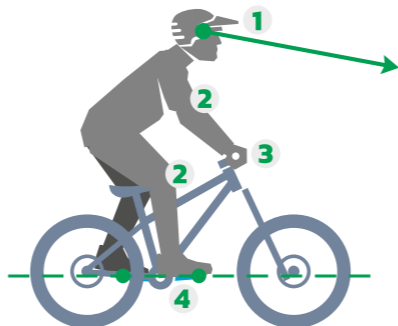

- 1 Look at the ramp in advance.
- 2 Relax your body, gently bend elbows and knees.
- 3 Get into a straight line as soon as possible towards the ramp, avoid the turns.
- 4 After reaching the required speed, hold the pedals parallel to the ground.

SECOND PHASE

DEEP squat as you approach the ramp

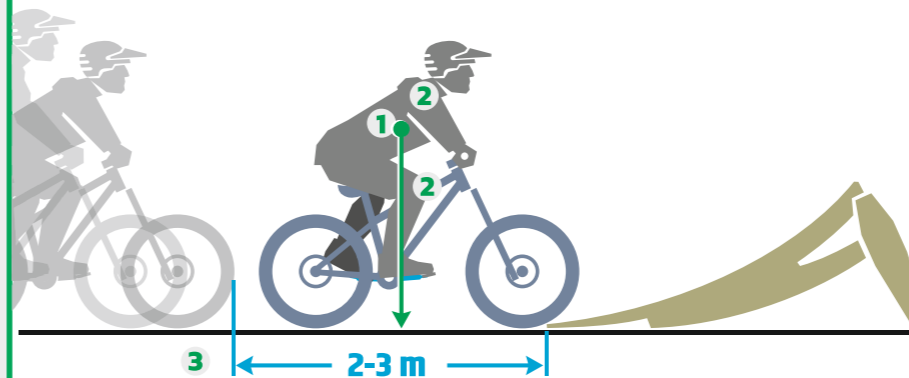

- 1 The squat is done vertically down. The body's center of gravity is in the middle of the bike.
- 2 Elbows and knees are quite strongly bent. Elbows wide, pointing outwards (not back). The chest gets closer to the handlebar and the hips to the seat.
- 3 Start squatting 2-3 m before the ramp.

THIRD PHASE

STANDING UP on the ramp

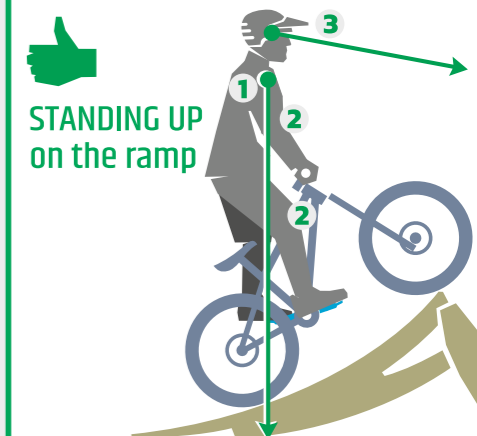

- 1 Standing up is done vertically upwards.
- 2 Body straight. Position body above BB. Elbows and knees straight.
- 3 Raise your head and look at expected landing place.

Reason for UNSTABLE jump and unsafe landing



- 1 **Incorrect pedal position**
Pick up the right speed, stop pedalling as soon as possible and get into the correct pedal position.

Reason #1 for NOSE DIVE

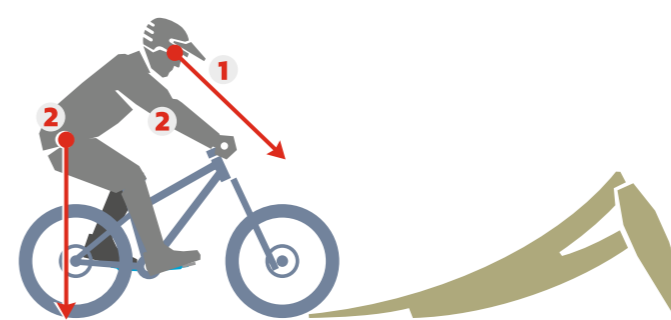

- 1 **Incorrect head position**
The eyes should not look down, but at the highest point of the ramp.
- 2 **Incorrect body position**
Avoid shifting weight over the rear wheel. Outstretched arms restrict full body movement before entering the ramp. A stiff body is one of the reasons for NOSE DIVE.

Reason #2 for NOSE DIVE

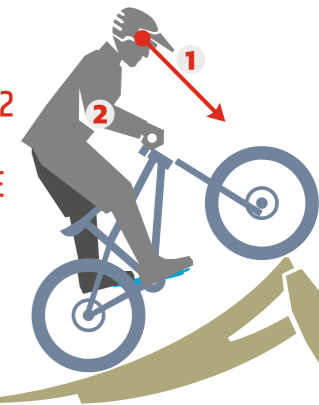

- 1 **Incorrect head position**
- 2 **Incorrect position of arms and body**
Driving onto the ramp you need to straighten both your legs and arms. A chin lift helps to achieve this, as if you wanted to emerge from under water.

MINI PAD ASSEMBLY

Follow engraved numbers on the parts. The numbers are showing the order of assembly. The numbers are on all connection points and have to match: (1 to 1; 2 to 2 and so on).

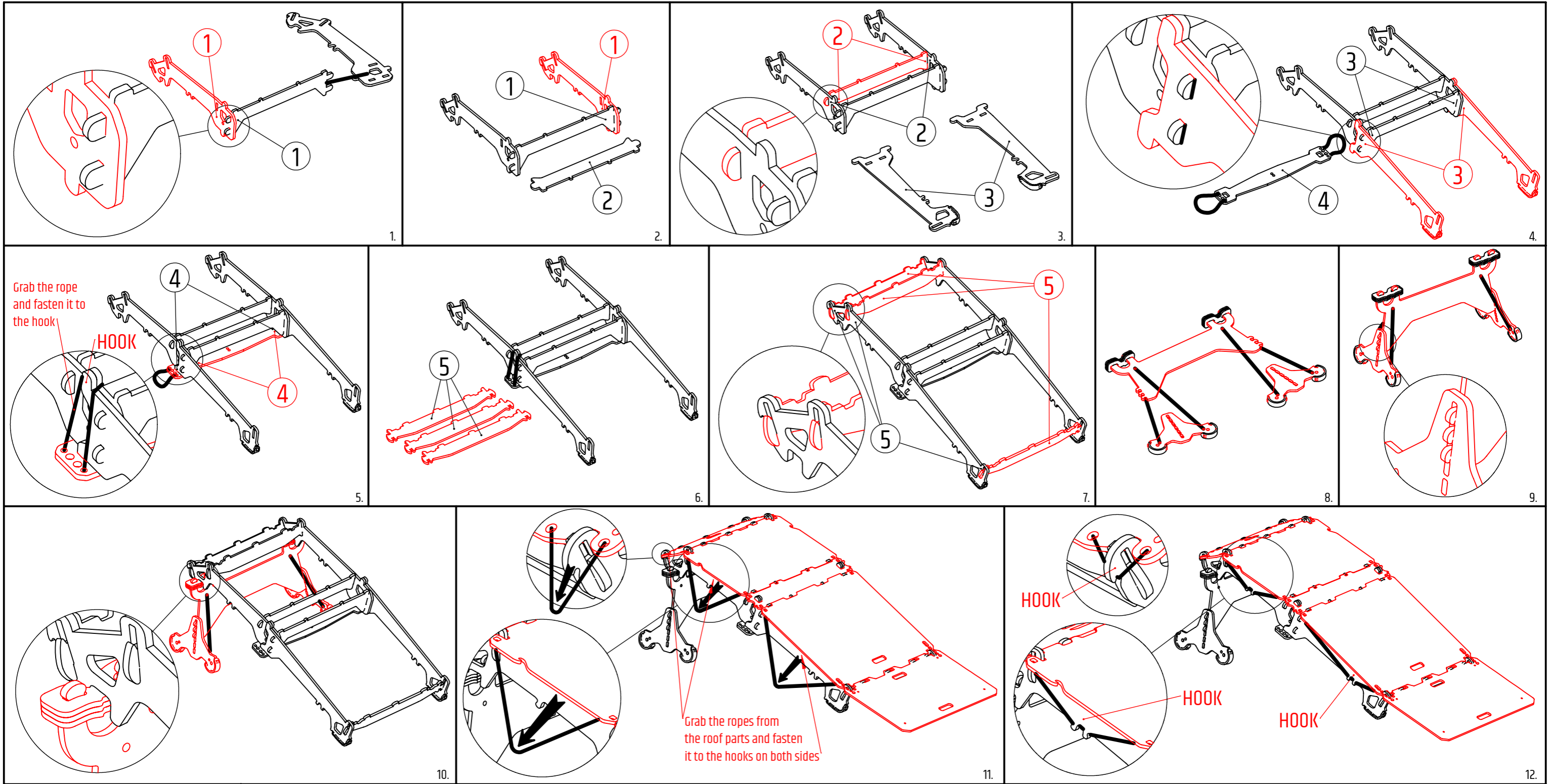

POSITIONS OF LEGS

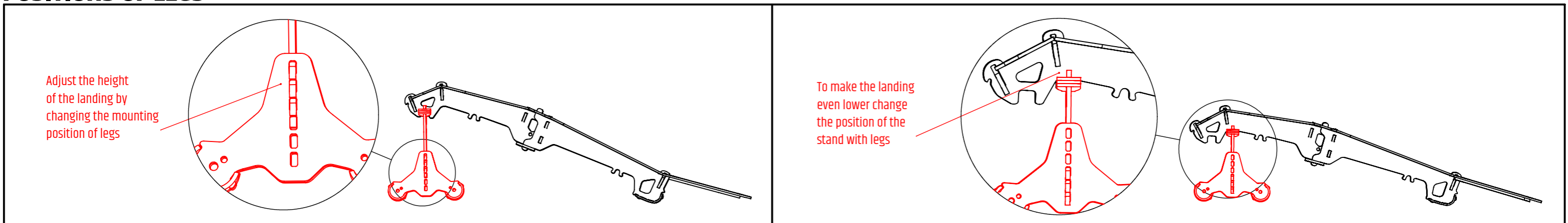

MINI PAD PACKING INSTRUCTIONS

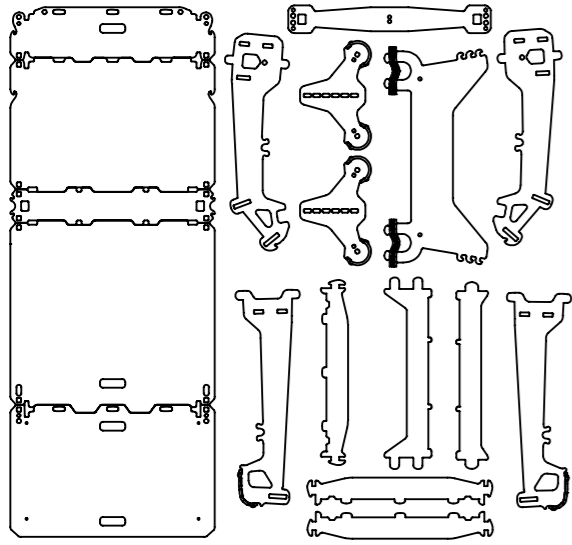

1.

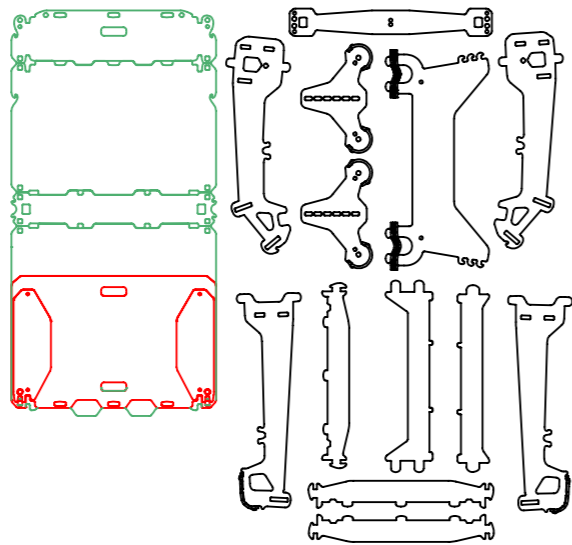

2.

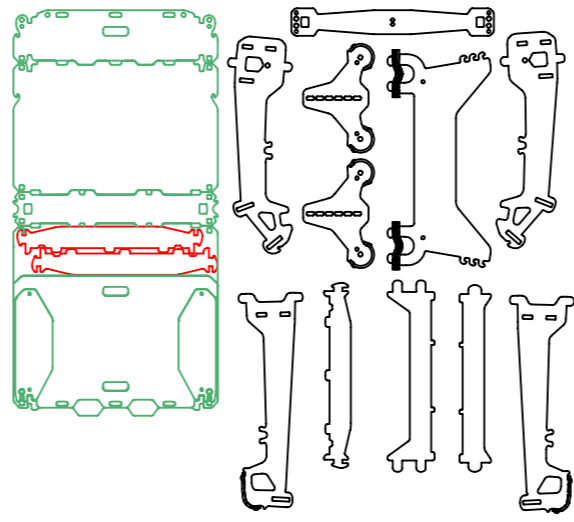

3.

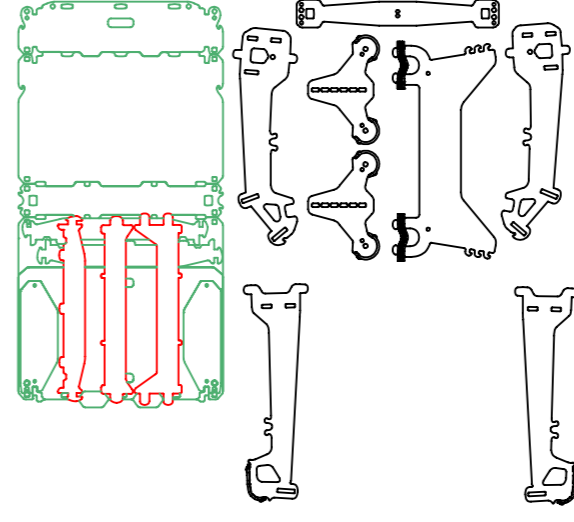

4.

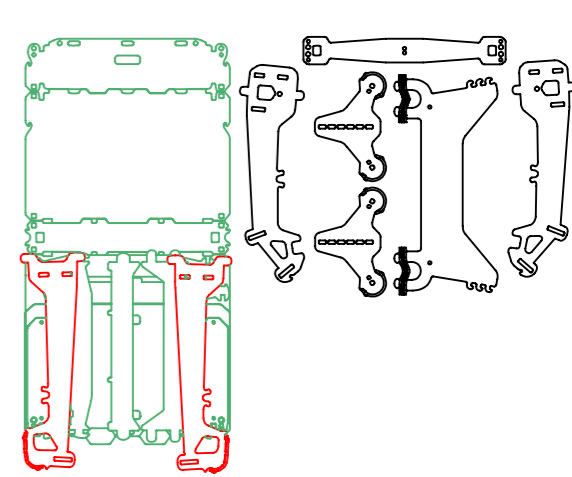

5.

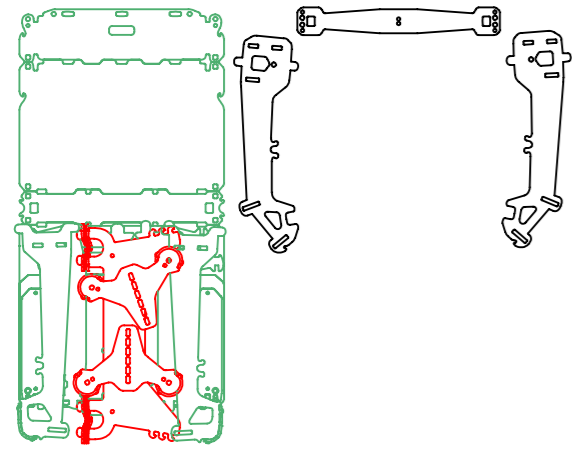

6.

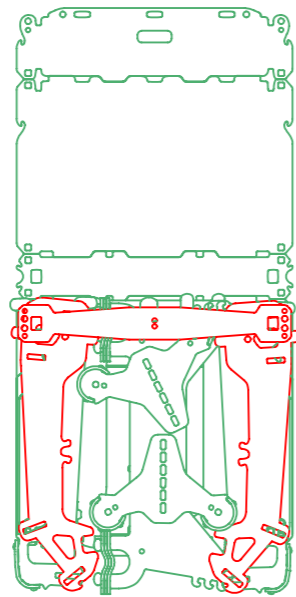

7.

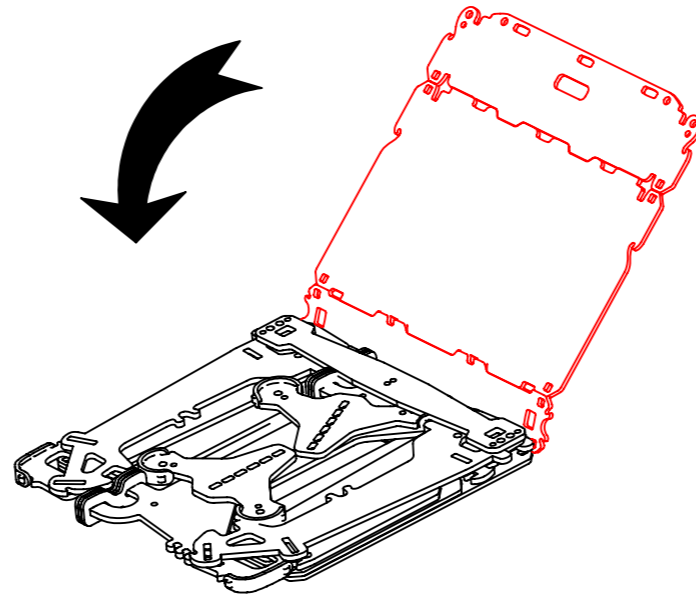

8.

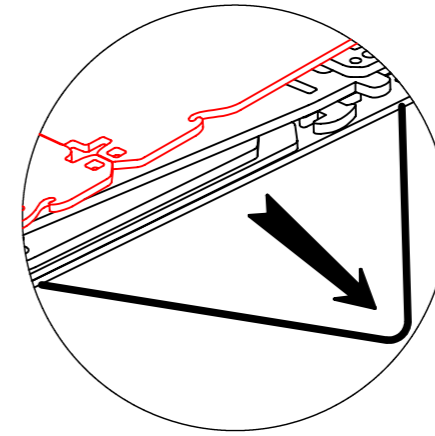

Grab the rope located under the briefcase

9.

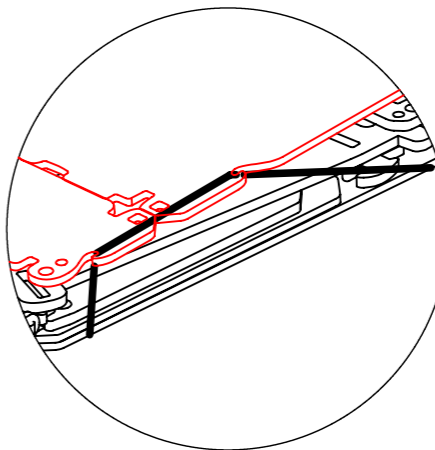

Fasten the rope to the hooks located on both sides of the briefcase

10.