

MATERIALS  
COLLECTION  
2023

# METAL FINISHES

All our finishes are handmade, and all surfaces are lacquered to provide a long lasting durability



Polished brass PB



Chrome CH



Satin Platinum SP



Orbital Bronze OB



Satin brass SB



Light burnished brass LB



Satin Titanium ST



Brushed Copper BC



Dark burnished brass DB



Black Gold BG

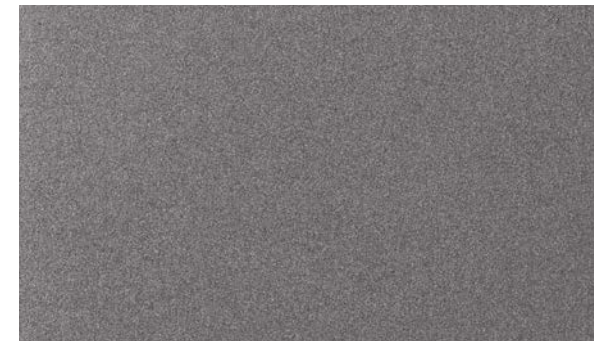

Deep Anthracite DA

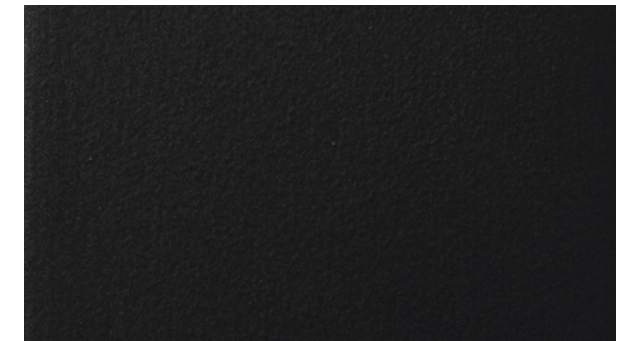

Deep Dark DD



Brown burnished brass BB



Brushed Silver BS



Deep Gold DG



Deep Silver DS

# MARBLE COLLECTION



Calacatta Gold CG



Carrara White CW

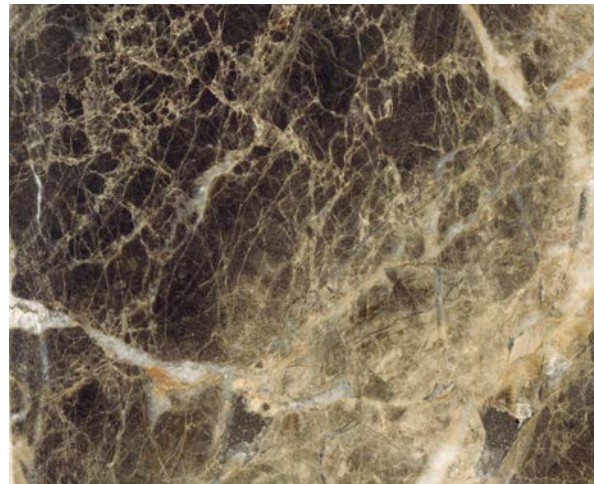

Emperador Dark ED

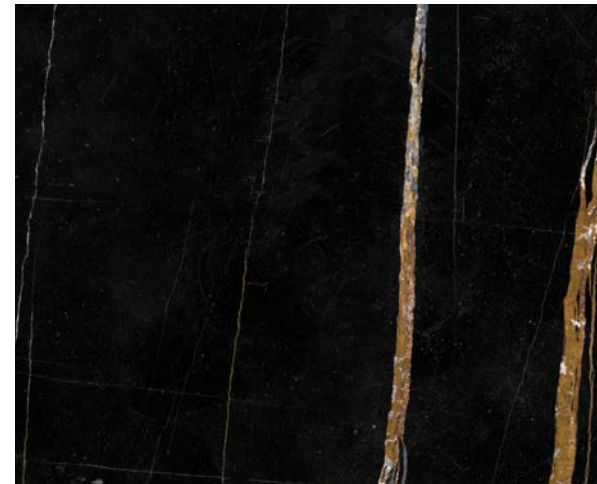

Sahara Noir SN



Verde Alpi VA



Travertino TV

# WOODS COLLECTION



Natural Oak



Bolivar



Canaletto Walnut



Mahogany



New Lime



Caleido

# CLUNIS



002

**Category**

Bouclé

**Composition**

33%WO-25%PL-25%PC-15%CO-2%PA  
 Width: 137 cm+/- 3%  
 Weight: 4935 gr/ml - 682 gr/sqm +/- 5%  
 Martindale: 40000 cycles+/-

**Flame resistance**

BS 5852-1 (1979) CIGARETTE  
 BS 5852:2006 CIGARETTE  
 BS 5852-1 (1979) MATCH  
 BS 5852:2006 MATCH  
 CAL TB 117:2013

**Washing Instructions**



002



006



028



026



000



029



030



020

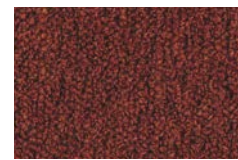

025

# SOFI



187-101

**Category**

Cotton and viscose frisé

**Composition**

46%CO-47%VI-7%LI  
 Width: 850 gr/ml - 607 gr/sqm +/- 5%  
 Weight: 850 gr/ml - 607 gr/sqm +/- 5%  
 Martindale: 27000 cycles +/- 10%

**Flame resistance**

BS 5852:2006 CIGARETTE  
 BS 5852-1 (1979) MATCH  
 BS 5852:2006 MATCH

**Washing Instructions**

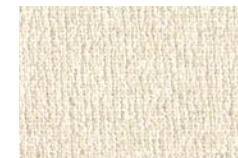

187-101



187-000



187-100



187-029



187-090



187-062

# REVIVE

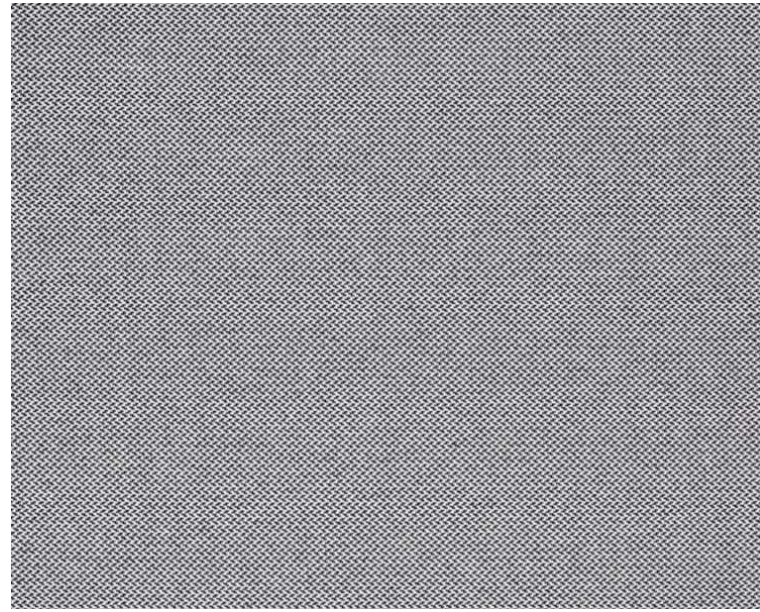

0154

**Category**

Kvadrat upholstery

**Composition**

100% recycled polyester FR  
 Width: Approx. 140 cm (Approx. 55")  
 Weight: 420 g/lin. m (13.55 oz/ly)  
 Martindale: 60.000  
 Sustainability: Greenguard Gold, HPD, EPD

**Flame resistance**

BS 5852 Crib 5 with treatment, EN 1021-1/2,  
 DIN 4102 B1, IMO FTP Code 2010: Part 8, NF D  
 60 013 with treatment, Önorm B1/Q1, UNI 9175  
 1IM, US Cal. Bull. 117-2013



0154



0274



0324



0434



0454



0944



0974

# ADAMO & EVA

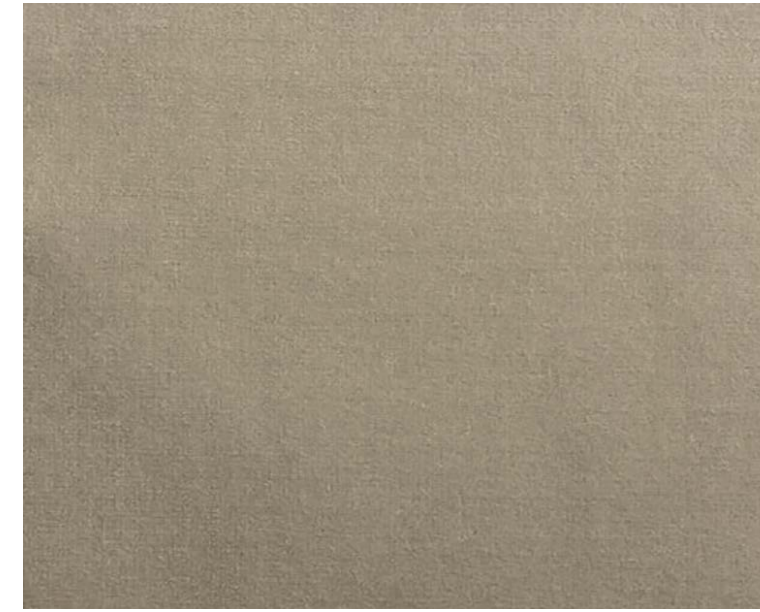

129 - roccia

**Category**

Cotton Velvet

**Composition**

100%CO  
 Weight: g/ml 630  
 Width: cm 140 - 55.12 inches  
 Cfa: Yes  
 Martindale: 50.000

**Washing Instructions**



116 - cayenne

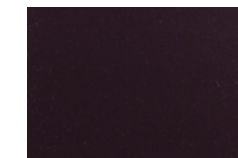

119 - prugna

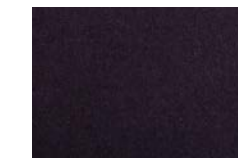

106 - mirtillo



168 - mousse



145 - olive

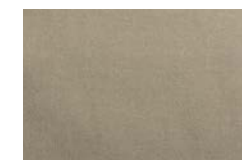

129 - roccia

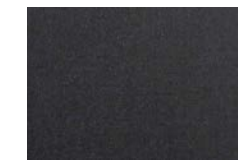

107 - antracite



169 - cactus



104 - indigo



170 - notte

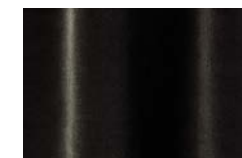

175 - fumo

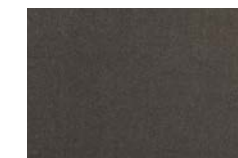

137 - cenere

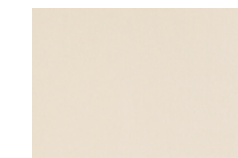

178 - ostrica

An exquisite quality of Italian-made cotton velvet that is soft, versatile and hard-wearing. A palette of 13 colours comprising striking, traditional and neutral shades.

# TABULARASA

Only for Love chair



161 - malachite

**Category**  
Cotton Satin

**Composition**  
100%CO  
Weight: g/ml 469  
Width: cm 140 - 55.12 inches  
Cfa: Yes  
Martindale: 30.000

**Washing Instructions**



103 - ninfea



161 - malachite



156 - ottanio



rose - 173

An elegantly modern cotton satin whose sheen enhances an extraordinary colour palette. Versatile and hardwearing, it provides the basis for infinite possibilities of fabric coordination, also using the Babà trimmings collection.

# BOGARDINE



003 - perla

**Category**  
Jacquard

**Composition**  
31%CV 26%CO 24%PAN 10%LI 8%WO 1%PA  
Weight: g/ml 960  
Width: cm 140 - 55.12 inches  
Curtain, Upholstery For Medium/Hard Use  
Cfa: Yes  
Martindale: 40.000

**Washing Instructions**

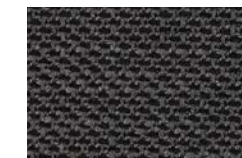

001 - quasinerò



002 - taupe



003 - perla



004 - naturale

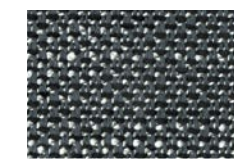

008 - ottanio



009 - bianco

Yarns of different types and thicknesses create a textural weave and confer a slight matelassé effect to the surface. Soft and consistent to the hand, hardwearing and ideal for heavy duty seating.

# SINEQUANON

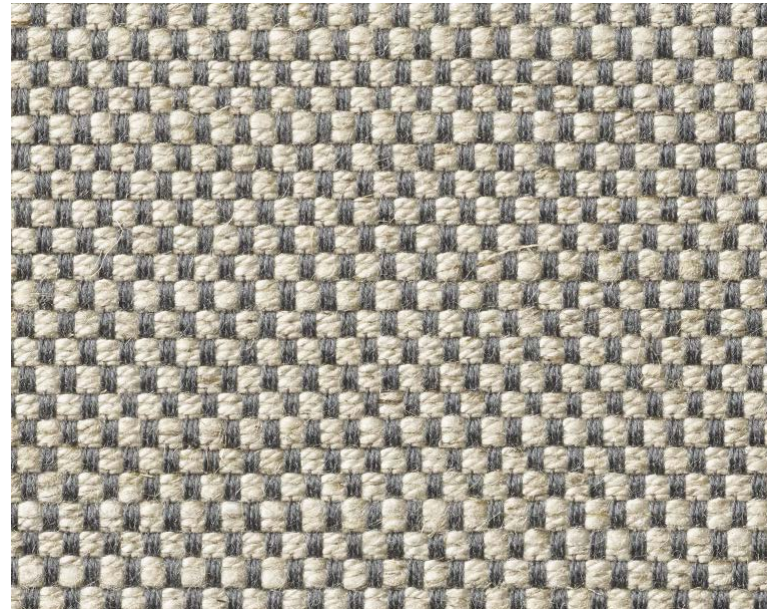

01 - argento



01 - argento



02 - taupe

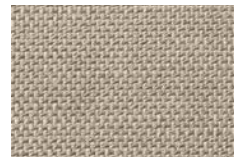

05 - stone



07 - perla



37 - caffè arabica

## Category

Linen and Viscose fabric

## Composition

60%CV 16%LI 13%CO 6%PES 5%PAN

Weight: g/ml 663

Width: cm 140 - 55.12 inches

Cfa: Yes

Martindale: 35.000

## Washing Instructions

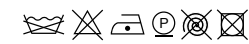

# CLAY



0010



002



004



005

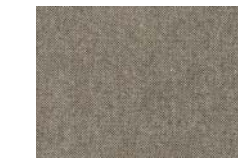

009



0010



0013



0015



0015

## Category

Upholstery

## Composition

76% Linen, 21% Cotton, 3% Polyester

Pattern: Solid

Weight: 770 g/lin.m

Width: 140 cm

Durability: 45.000 Martindale

Pilling: 4

Lightfastness: 5

## Washing Instructions



Panama weave with slightly shot yarns. Even here the Dedar offer extends with the linen and viscose cloth, which is durable, bright, boasts a rich texture (Flair, Fifty Fifty, Chambray, Aut Aut, Arbus). A special, careful blend of linen and viscose and a new construction which enables a reduction of the textile weight whilst guaranteeing the aesthetic quality, usage and durability, and also offering good value. This textile, just like the others in this range, feature a waterrepellent treatment which offers specific protection from liquids and oils.

Bringing together both natural beauty and a sense of finesse, the creative team have mixed colours of yarn in warp and weft to create an elegant yet casual fabric. The result has a unique structured surface that adds an extra dimension to any interior design scheme. With a back cloth that gives extra stability, Clay is perfect for upholstering furniture. The colours are inspired by the designer's love of both art and interiors and include cool shades of cement, blue, and salvia but also the natural shades of wood and clay.

# TWILLTWENTY



4 - cipria

## Category

Twill

## Composition

100%PI Flame Retardant  
 Width: 140 Cm  
 Weight: 630 Gr  
 Made in: Italy  
 Martindale: 80000  
 Pilling: 4/5 (Scale 1-5)  
 Colour Fastness To Light: 7 (Scale 1-8)  
 Colour Fastness To Crocking: 4/5 Dry 4/5 Wet (Scale 1-5)  
 Colour Fastness To Chlorinated Water: 4/5 (Scale 1-5)  
 Colour Fastness To Sea Water: 4/5 (Scale 1-5)  
 Tensile Strength: Class A (En 14465)  
 Tear Strength: Class A (En 14465)  
 Seam Slippage: Class A (En 14465)  
 Other Certifications: Yarns Certified Oeko-Tex  
 Fire Certifications: France M1 Nfp902-503-504-505, Germany B1 Din 4102-1, Imo 8 Upholstery, Italia Classe 1 Tendaggi, Uk Cigarette Source 0, Uk Contract Curtains Bs5867, Uk Contract Upholstery Bs7176, U.s.a. Cal Tb117

## Washing Instructions

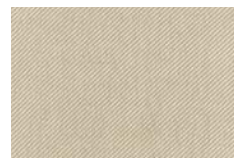
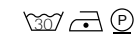

4 - cipria

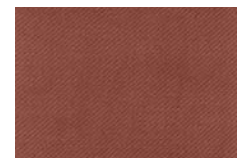

20 - ruggine



7 - nero



6 - grigio

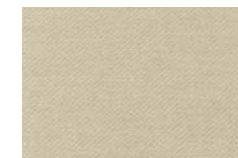

3 - corda

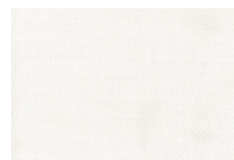

1 - bianco



9 - pesca



12 - pervinca

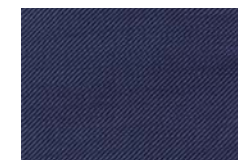

17 - blue



19 - bordeaux

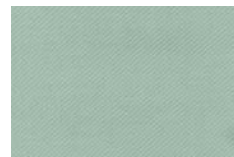

13 - acqua



16 - teal blue

A classic twill. A particularly thick thread/yarn highlights the "Z" diagonal motif which makes the fabric more dynamic. The shiny and matt threads enhance the effect of the light on the surface.

# SAFIRE



003

## Category

Boucle and chenille

## Composition

43% Viscose, 17% Acrylic, 15% New wool, 9% Cotton, 8% Linen, 8% Polyester  
 Weight: 1010 g/lin.m  
 Width: 140 cm  
 Durability: 44 000 Martindale  
 Pilling: 3  
 Lightfastness: 6  
 Sustainability: Greenguard Certification

## Washing Instructions

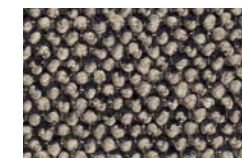
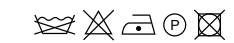

003



004



005



008

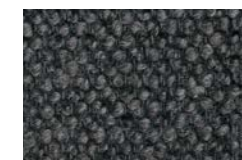

010

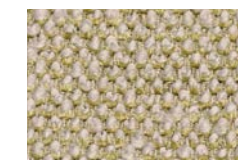

015



017



# CORD



CA1419/053

**Category**

Cotton Velvet

**Composition**

100% cotton, groundmaterial: 100% cotton  
 Width: 140 cm  
 Durability: 100 000 Martindale

**Washing Instructions**

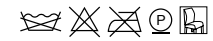

CA1419/053

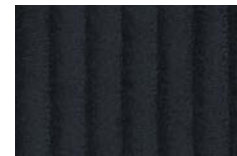

CA1419/084



CA1419/070



CA1419/071



CA1419/091



CA1419/020



CA1419/032



CA1419/064



CA1419/051



CA1419/037



CA1419/093

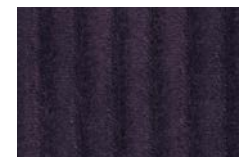

CA1419/081

# BONSAI



020

**Category**

Upholstery

**Composition**

48% PAN 29% CO 23% PES  
 Weight: 140 cm  
 Width: 905 per linear meter/g  
 Width: 646 per square meter/g  
 Durability: 50 000 Martindale  
 Seam slippage: <6mm  
 Pilling (DIN EN ISO 12945-2)  
 Rub fastness: Dry 4-5 Wet 4-5  
 Lightfastness: for medium colours 5

**Flame retardant**

BS 5852: Part 1: 1979  
 Ignition source 0 (Cigarette)

**Fabric**

Wave Dobby

**Washing Instructions**



020



021



093



072

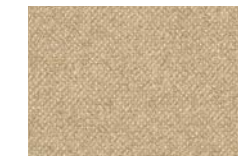

041



032

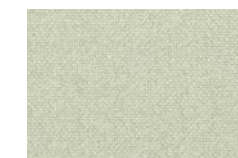

082



051

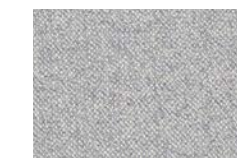

050

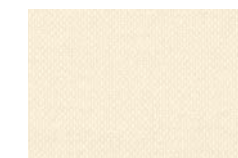

070

# TIVANO



3611 - corda



3611 - corda



3606 - tabacco

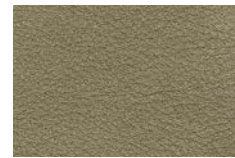

3603 - militare



3612 - fumo

## Category

European cattle

## Composition

Raw material: European cattle

Tanning: Mineral

Protection: Semianiline

Description: Waxed hand buffed

Thickness: 1,2 - 1,4 mm

Average size: 5,0 m<sup>2</sup>

Dry finishing locking	EN ISO 11644	≥ n.a. N/cm
Tear resistance	EN ISO 3377-1	≥ 20 N/cm
Flexing endurance	EN ISO 5402	≥ 20.000 runs
Dry rub colour fastness	EN ISO 11640	150 runs ≥ 4 grey scale
Wet rub colour fastness	EN ISO 11640	25 runs ≥ 4 grey scale
Light fastness	EN ISO 105-B	≥ 4 blue scale
Heat colour fastness	EN ISO 17228	≥ 4 grey scale

Avoid exposure to direct sunlight and heat sources

Clean frequently and gently with a soft cloth

Remove stains with a damp cloth or with a specific cleaning product

# CUOIO LEATHER

Only for Frame sofa and armchair



naturale

## Composition

Bovine of European origin in Nabuk finishing, natural grain.

Average thickness 1.8/2.0 mm. Chrome tannage.

Aniline dyed with pigmented finish.

The possible presence of any imperfections testify the authenticity and the natural look of pure cuoio leather.



avorio

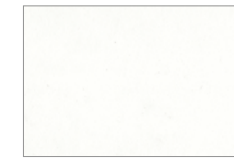

bianco



grigio



naturale



nero

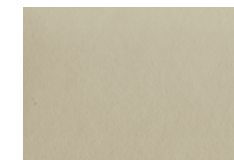

nocciola



rosso bulgaro



sabbia



tabacco



testa di moro



tortora



verde fango

# KAIROS COLLECTION



1716 - doeskin

**Category**

Nabuck leather

**Composition**

Bovine of European origin in Nabuk finishing, natural grain.  
 The average size of each skin is around 5.0 sqm. Chrome tannage.  
 Aniline dyed, finished with high quality oils. Suede look, soft and velvet touch.  
 The possible presence of any imperfections testify the authenticity and the natural look of pure aniline leather.  
 Average thickness 1,2 - 1,4 mm.



1719 - kangaroo

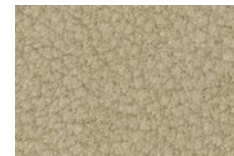

1716 - doeskin

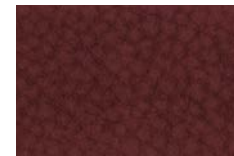

1714 - lucky

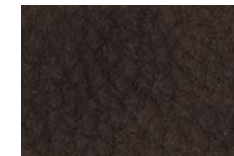

1704 - chocolate forest



1701 - caqui

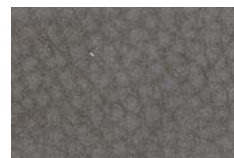

1711 - cenere



1721 - ematite



1715 - elephant

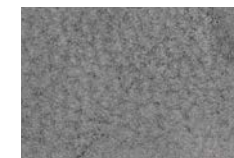

1710 - plomo

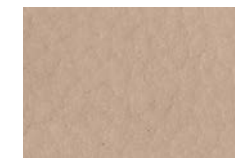

1718 - nude

# LINEA COLLECTION



647 - grigio perla

**Category**

High quality bovine leather with lightly buffed natural grain

**Composition**

Bovine of European origin, lightly buffed natural grain, finished thickness 0.9 - 1.1 mm.  
 The average size of each hide is around 4.8 - 5.0 sqm. Chrome tannage.  
 Through dyed; finishing with resins and pigments. Article with a pigmented and protective coat, with a soft, waxy feel and semi-matt appearance.

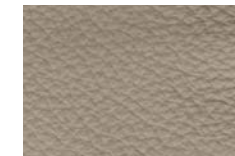

629 - stone

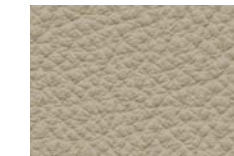

647 - grigio perla

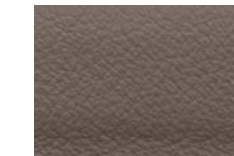

677 - malt

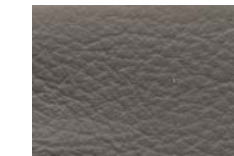

660 - asfalto



675 - new grey

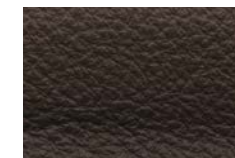

612 - castagna

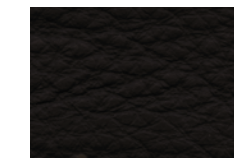

611 - testa moro



656 - cotto

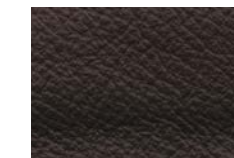

610 - mogano

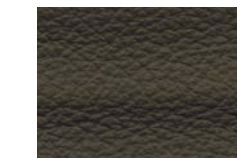

632 - verdone



622 - nero

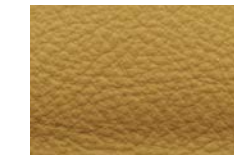

619 - gallino



634 - gesso

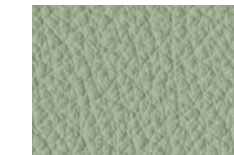

674 - octane

# AIDA COLLECTION



Daino

## Category

Nappa Smooth leather

## Composition

Average size 4,5-4,8 sqm, thickness 0,9-1,1 mm.

Chrome tannage.

Bovine leather with smooth aspect, aniline finished with some oils and waxes, produced on European bull.

Aniline dyed, finished with high quality oils. Soft article with a slight two tones effect, emotional touch.

The possible presence of any imperfections and color variations are typical for this type of leather as they testify the authenticity and the natural look of pure aniline leather.

# TECHNICAL SPECIFICATIONS

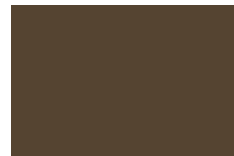

Daino

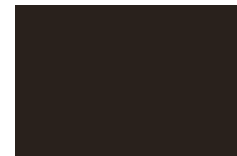

Coffee



Tan

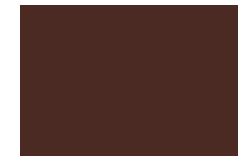

Saddle



Blackberry



Spruce



Nocturne



Mud



Grey



Sand

# Abbracci

Lorenza Bozzoli / Bed

## Structure

Internal structure in plywood panel and polyurethane rubber covered in fabric or leather.

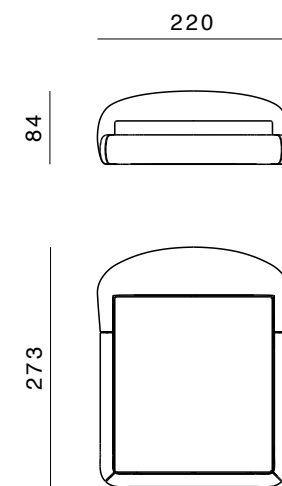

# Frame

Stefano Giovannoni / Beds

## Structure

The bed is based on the Frame family of castings. The frame castings are made of Italian aluminum, die casted in-house at Ghidini1961. Headboard and footboard in hand stitched natural saddle leather.

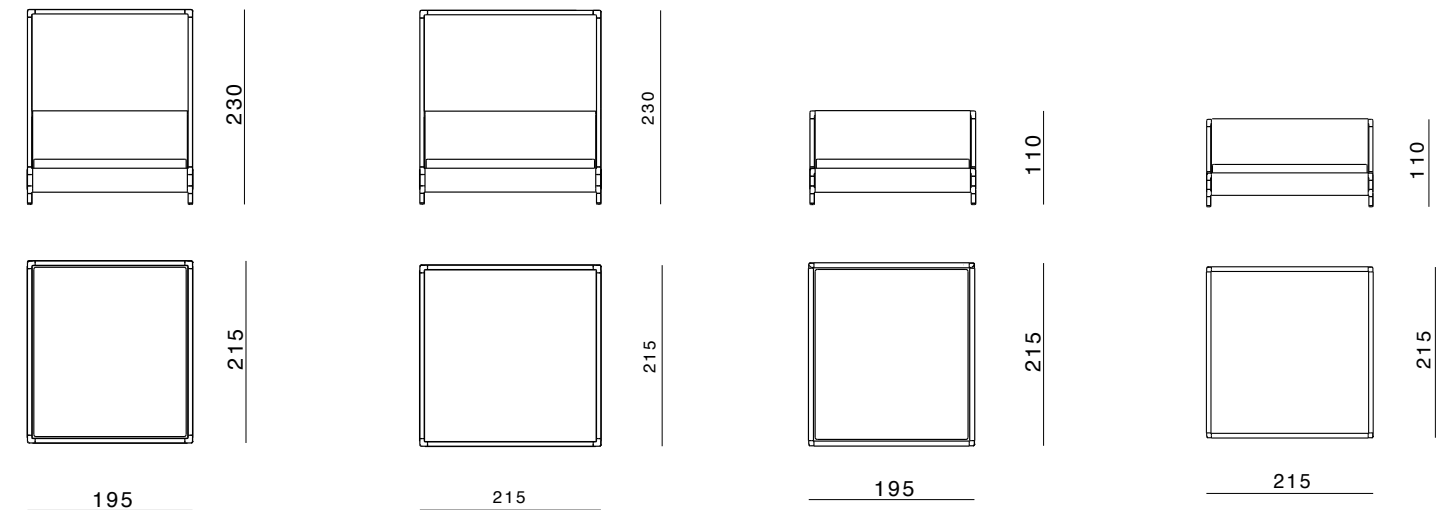

# Tarantino

Lorenza Bozzoli / Bed

## Structure

Internal structure in plywood panel and polyurethane rubber covered in fabric or leather.

Headboard by cushions in high grammage wadding with internal rubber insert, covered with a quilted goose down in cotton lining.

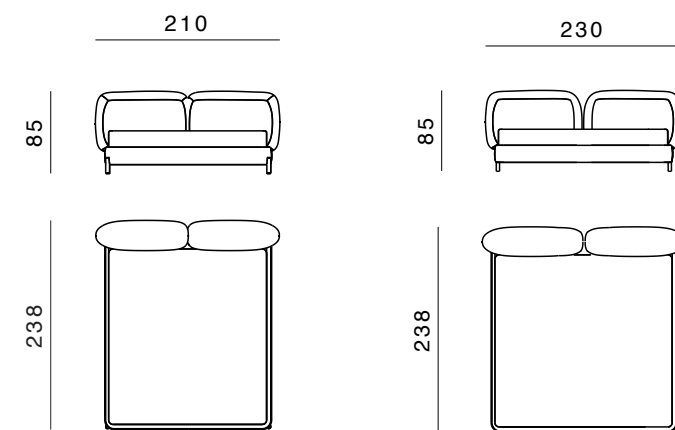

# Frame

Stefano Giovannoni / Cabinets

## Structure

33x60mm oval tubular in aluminium with die-cast corners. Galvanic finish in polished brass, or satin brass and painted burnished brass. Dark Tulip Wood veneered melamine container, matte acrylic polish.

## Interior

interior shelving and internal bases in wood. Opening with internal push system

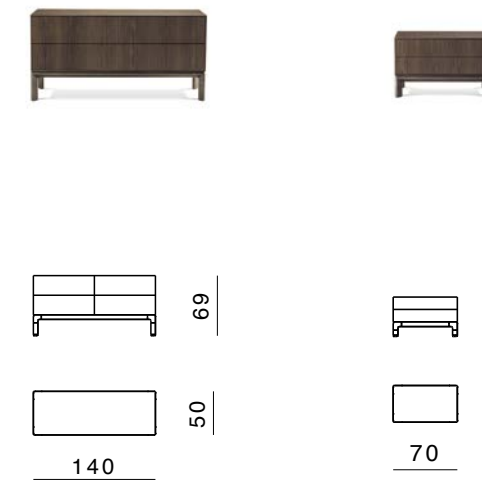

# Tarantino

Lorenza Bozzoli / Cabinets

## Structure

Extruded aluminium for the supporting structure and for the handles. Wood veneered container.

## Interior

Interior shelving and internal bases covered in wood. Opening with internal push system.

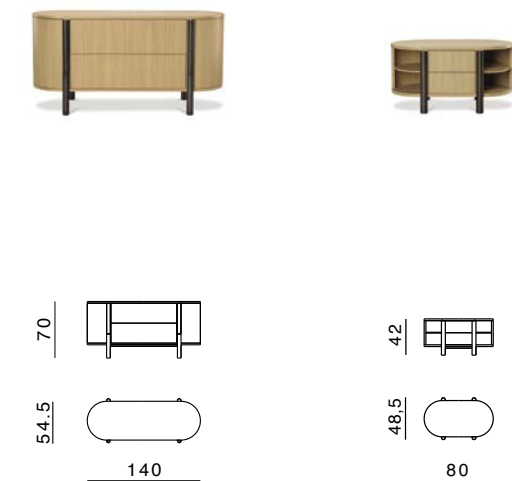

# Liù

Paolo Rizzatto / Chairs

### Structure

The legs, seat and backrest are in aluminum die casted in house at Ghidini1961. Cushions in high grammage wadding with internal wood insert.

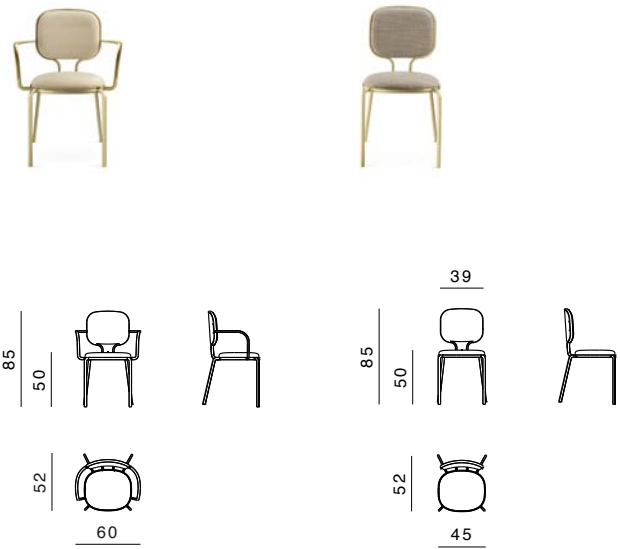

# Fabbrica

Branch Creative / Chair

### Structure

Structure in aluminum die casted in house at Ghidini1961. Seat and backrest available in leather or fabric.

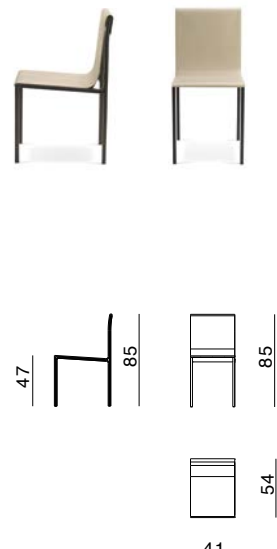

# Alfred and Hillary

Richard Hutten / Stools

### Structure Alfred

Metal structure in chromed iron. Seat and backrest in polyurethane rubber.

### Structure Hillary

Metal structure in chromed iron. Seat and backrest in molded polyurethane rubber.

### Alfred

### Hillary



# Arnold

Paolo Rizzatto / Side tables

### Structure

Base and table top in marble or wood. Central element made of a conic aluminum column.

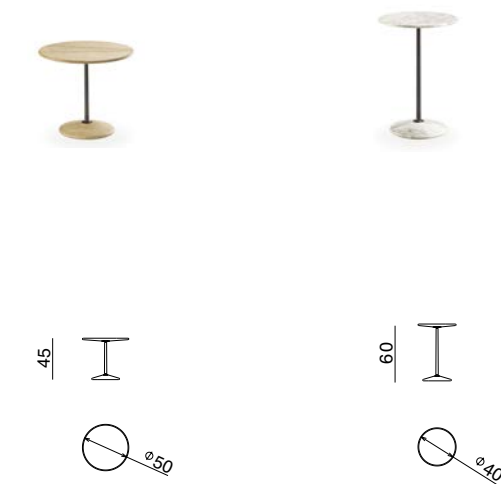

# Ottanta

Lorenza Bozzoli / Coffee tables

## Structure

Base structure in brass plated aluminum bended round tube. Internal structure with metal supporting frame

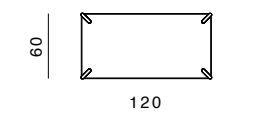
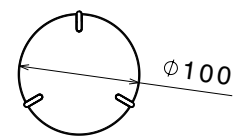
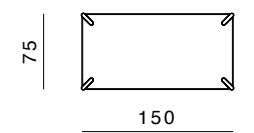
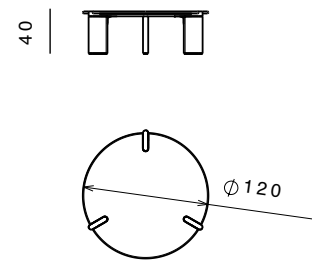
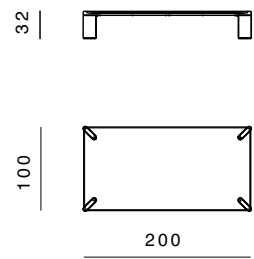

# Helios

Branch Creative / Lamps

## Structure

Metal structure in painted aluminum. Internal sphere and external cone made by blown glass. LED dimmable light.

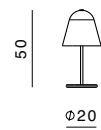
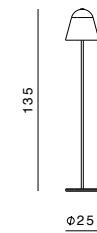

# Triple Waves

Lorenza Bozzoli / Rugs

## Material

New Zealand wool and Tencel

## Technique

Hand tufted  
The fleece can then be finished by hand to different thicknesses with the use of scissors.  
The fleece can be held as a "velvet" or a "loop" (small bouclé).

At the end of the weaving process, natural latex is poured on the back of the carpet, which gives greater compactness to the structure of the carpet.  
Finally, a cotton cloth is applied on the back as a finishing touch.

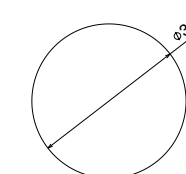
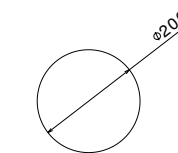
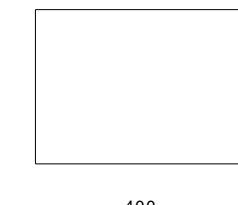
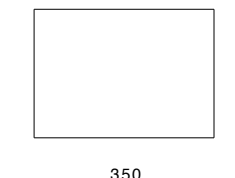
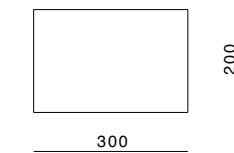
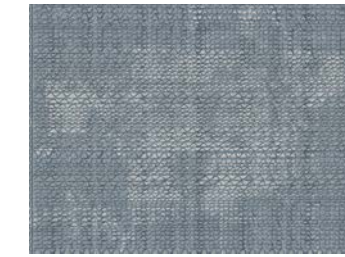



# Connect

Richard Hutten / Rugs

## Material

New Zealand wool and Tencel

## Technique

Hand tufted

The fleece can then be finished by hand to different thicknesses with the use of scissors.

The fleece can be held as a "velvet" or a "loop" (small bouclé).

At the end of the weaving process, natural latex is poured on the back of the carpet, which gives greater compactness to the structure of the carpet.

Finally, a cotton cloth is applied on the back as a finishing touch.

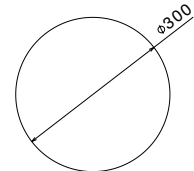
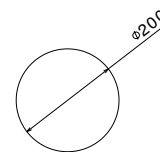
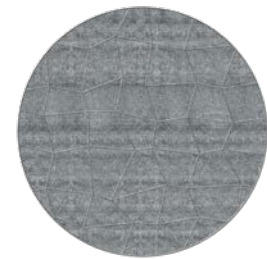
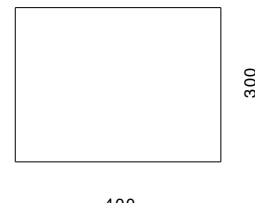
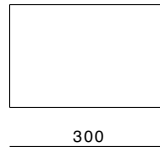
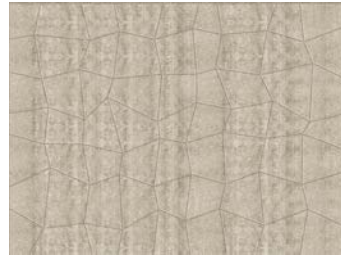

# Plumose

Richard Hutten / Rugs

## Material

New Zealand wool and Tencel

## Technique

Hand tufted

The fleece can then be finished by hand to different thicknesses with the use of scissors.

The fleece can be held as a "velvet" or a "loop" (small bouclé).

At the end of the weaving process, natural latex is poured on the back of the carpet, which gives greater compactness to the structure of the carpet.

Finally, a cotton cloth is applied on the back as a finishing touch.

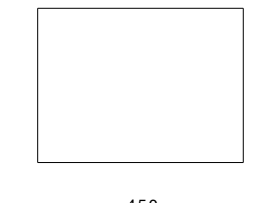
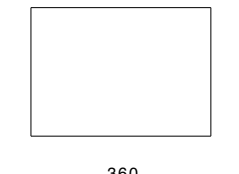
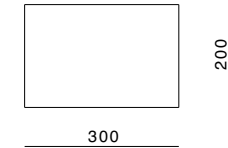

**Photos**

Fabrizio Bergamo  
Cube Photoproduction

**Styling**

Candida Zanelli, Rosaria Galli

**Branding**

Christoph Radl, Antonella Provasi

**Graphic layout and Printing**

Intese Grafiche, Montichiari (Bs)

**Many Thanks to:**

Jab  
Nason Moretti

**GHIDINI 1961 INICIHQ**

is a trademark of  
Ghidini Giuseppe Bosco spa

via Gabriele D'Annunzio 27  
25069 Villa Carcina (BS) Italy  
T +39 030 8980521  
F +39 030 8981588  
info@ghidini1961.com

**Press office**

press@ghidini1961.com

**Sales office**

sales@ghidini1961.com

www.ghidini1961.com

