

9216e Installation and User Guide

AVSTRA

Table of Contents

| | | | |
|---|-----------|---|-----------|
| Key Descriptions | 1 | Memory keys | 13 |
| Basic Installation | 3 | Saving numbers and names in memory keys | 13 |
| Connecting the handset cord | 3 | Entering Names | 13 |
| Connecting the line cords on Line 1 | 3 | Saving from the display into memory keys | 14 |
| Connecting the power adaptor | 4 | Labeling the memory keys | 14 |
| Checking your telephone | 4 | Making calls from memory keys | 14 |
| Connecting an optional modem or fax | 4 | Editing memory keys | 15 |
| Desk Mounting | 5 | Deleting memory keys | 15 |
| Wall Mounting | 5 | Saving features in memory keys | 15 |
| Basic Features | 6 | Using feature keys | 16 |
| Making a call | 6 | Saving a feature and light in memory keys | 16 |
| Answering a call | 6 | Using FeatureLight keys | 16 |
| Putting a call on hold | 6 | Advanced Features | 17 |
| Listening to your callers | 7 | Adding a timer key | 17 |
| Using the Redial List | 7 | Using the Call Timer | 17 |
| Telephone Setup | 8 | Deleting a timer key | 17 |
| Changing the display language | 8 | Entering area codes | 18 |
| Setting the date and time | 8 | Display messages and lights | 19 |
| Turning the ringer ON and OFF | 9 | Knowing when you have a message | 19 |
| Setting the ring tone and ringer volume | 9 | Clear Message Waiting | 19 |
| Controlling the ringer volume | 9 | Viewing multiple display and light messages | 19 |
| Controlling the receiver volume | 9 | Learning about the lights | 19 |
| Controlling the speaker volume | 9 | Set indicator light messages | 19 |
| Callers List | 10 | General display messages | 20 |
| Using the Callers List | 10 | Callers List display messages | 21 |
| Making a call from the Callers List | 10 | Helpful Hints | 22 |
| Editing in the Callers List | 11 | Index | |
| Saving from the Callers List | 11 | | |
| Deleting from the Callers List | 12 | | |
| Changing the Callers List | 12 | | |

Key Descriptions

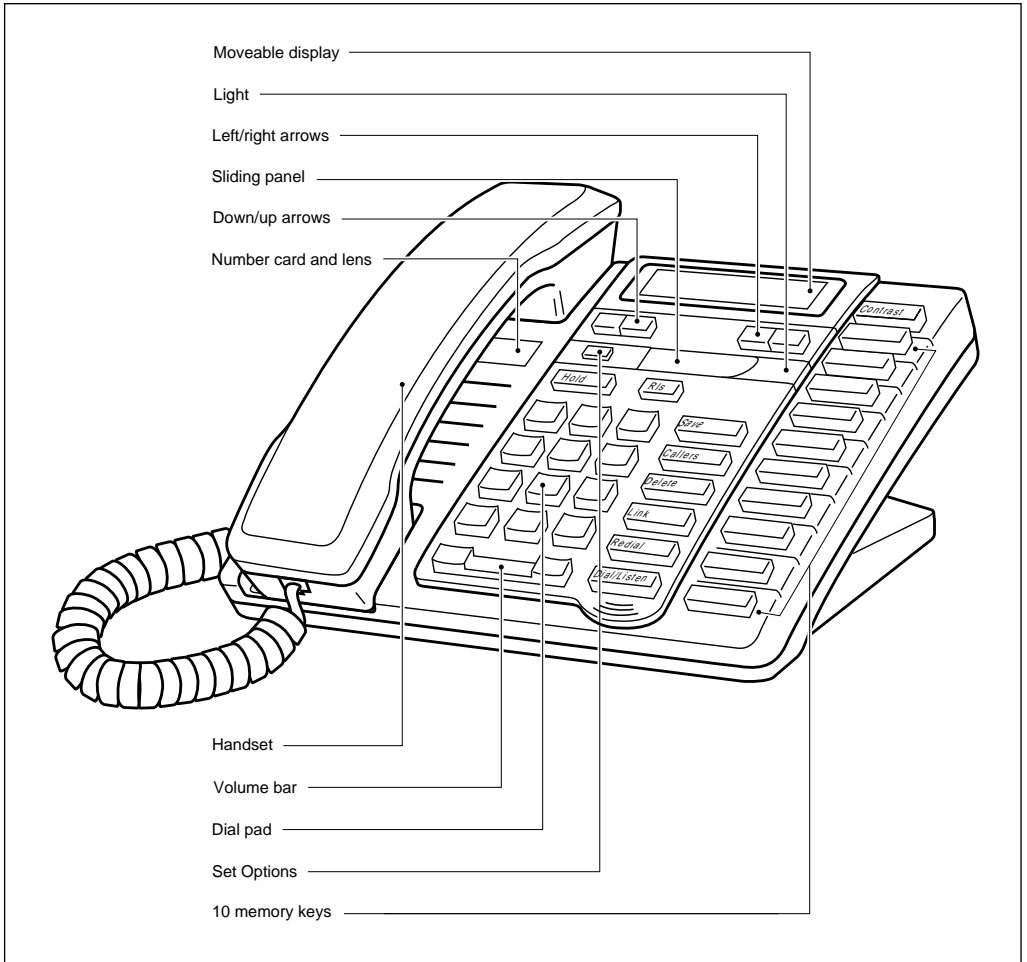

 Contrast

Cycles through eight settings to adjust the display contrast.

 Save

Stores numbers and names in memory keys.



Allows you to move up and down any list such as the Set Options or Callers List.



Allows you to backspace and erase when predialing and when adding or changing numbers and names in memory keys.



Adds a space when entering names in the Callers List or memory keys. Allows you to view status messages on the display.

- The unlabeled Set Options key is hidden under the sliding panel. This key gives contains seven options that customize the basic setup of your telephone.
- Puts the call on hold.
- Always hangs up a call. Also allows you to leave any list such as the Set Options List or the Callers List.
- Allows you to access a list of people who called.
- Allows you to erase memory keys and delete items in the Callers List.
- Allows you to access network features such as Call Waiting. Link is also referred to as Flash.
- Displays the last number you dialed. Allows you to listen without lifting the handset.
- Selects your line and dials any displayed number.
- Lets you adjust the receiver, speaker, and ringer volume.
- Memory keys store numbers, names, and features.

Basic Installation

This section contains the information you need to install your 9216e telephone.

Connecting the handset cord

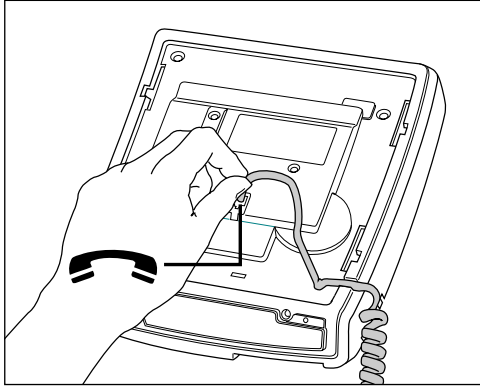

Attach the handset cord  .

Attach one end of the handset cord to the handset and the other end to the handset jack.

Connecting the line cord on Line1

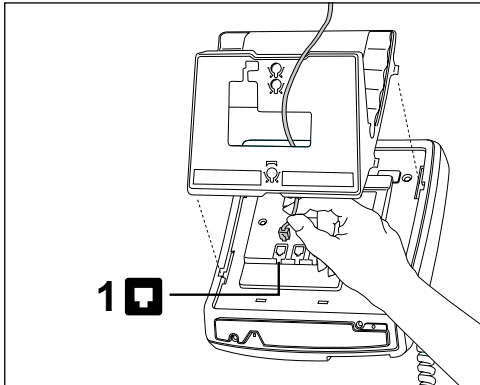

Attach the line cord in jack number 1, as shown by 1 .

Attach one end of the line cord to jack number 1 and the other end of the line cord to the wall jack.

Connecting the power adaptor

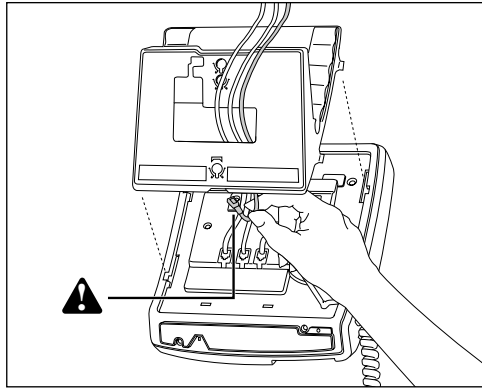

Attach the power adaptor cord ⚠

Attach the power adaptor to the base of the telephone, where the warning symbol is marked. Then connect the power adaptor into the closest electrical outlet.

Checking your telephone

When you first plug in your 9216e, you may see a message asking you to make a language selection. Follow the directions on the display to select one of the languages.

Your telephone also runs a test to ensure that the line cord is connected properly. If the test fails, the display prompts you to check the line cord. Ensure that all connections are fastened securely.

Connecting an optional Fax machine

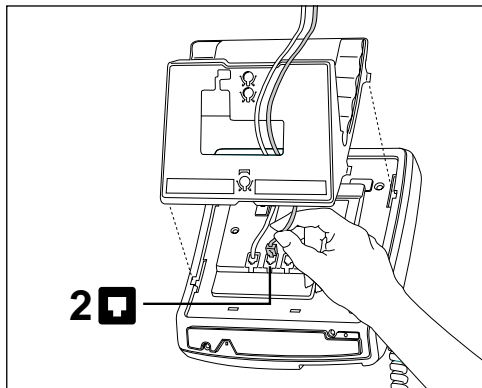

For your fax machine, answering machine or modem; attach the line cord in jack number 2 as shown by 2 .

Attach one end of the line cord to jack number 2 and the other end of the line cord to the peripheral. Line cords for a fax machine, modem or answering machine do not come with the M9216e.

Mounting the 9216e

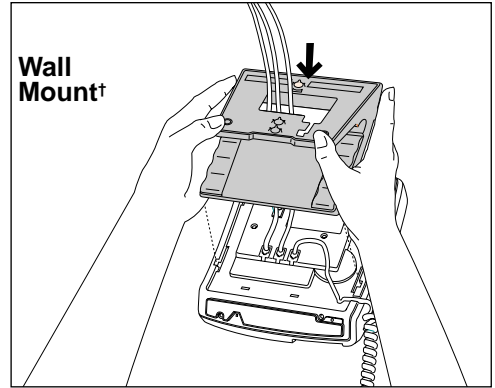
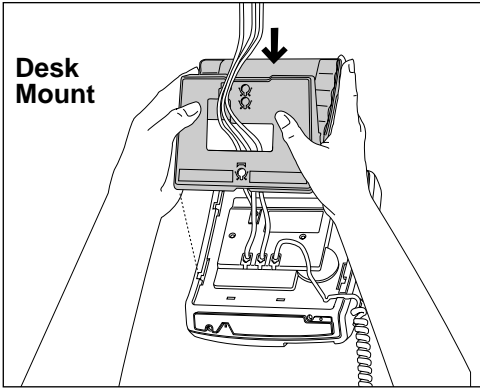

Lower the stand into the slots on the base of the telephone, as shown in the desk or wall mount illustration above.

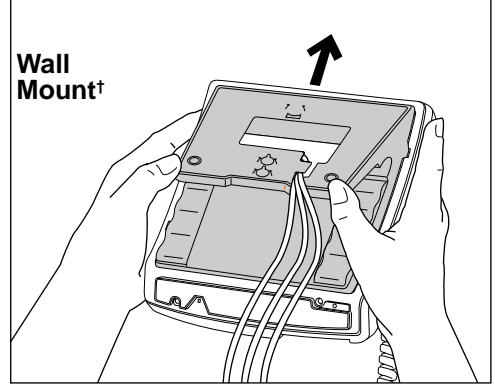
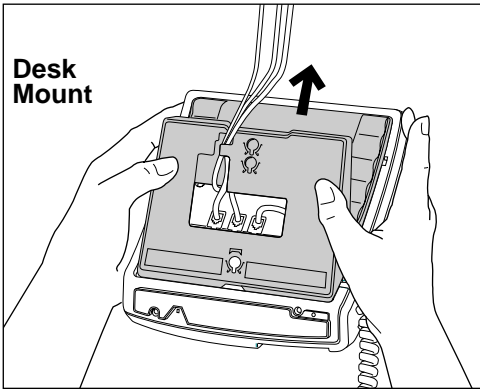

Slide the stand back until it clicks into the locked position, as shown in the desk or wall mount illustration above. The excess line cord fits into the stand of the telephone.

Note: The Load number (LN) is 14 and the Ringer Equivalence Number (REN) is 1.4B for the 9216e telephone. Please see the base of your telephone or the Regulations sheet for more regulatory and safety information.

†We recommend that you use a wall mounting plate, which your telephone company or Telecom manager can install.

Basic Features

Making a call

With the 9216e you can make a regular call or predial a telephone number. Predialing allows you to check the number before it is dialed out. Follow the procedures below to make a regular or predialed call.

To make a regular call:

1. Lift the handset.
2. Enter the number using the dial pad.

To make a predialed call:

1. Enter the number using the dial pad.
2. Lift the handset then press **[Dial/Listen]**.

Answering a call

To answer a call:

1. Lift the handset or press **[Dial/Listen]**.

Calling line identification information is sent from the telephone company to your 9216e telephone between the first and second ring. Therefore, if you want the telephone number of the incoming call to appear on the display and in the Callers List, you must wait until the information appears on the display before answering the telephone.

Putting a call on hold

When you put a call on hold it is important to hang up the handset.

To put a call on hold and take a call off hold:

1. Make or answer a call.
2. Press **[Hold]**. The display shows that the call is on hold.
3. Hang up the handset.
4. To retrieve the call, lift the handset or press **[Hold]**.

Note: If you don't retrieve the call after 15 minutes, the call is automatically dropped.

Two things can happen if you don't hang up the handset after you have put a call on hold:

- When the call you have put on hold is picked up at another extension, the call remains connected to your telephone and is taken off hold. This means any background noise from your area will be heard by the caller and the other extension.
- If an incoming call is placed on hold and no one at another extension picks up the handset, the telephone will drop the held call after 15 minutes and re-establish dial tone.

Listening to your caller

To monitor a call when someone puts you on hold:

1. Press **Hold**.
2. Hang up the handset.
3. To turn the speaker ON, press **Dial/Listen**.
4. When you hear the caller back on the line, pick up the handset.

Using Redial

If you do not remember the number you just dialed, or you do not want to dial the whole number again, use the Redial key.

To make a call from Redial:

1. Press **Redial**. The display shows the last number you dialed.
2. Lift the handset, then press **Dial/Listen**.

Telephone Setup

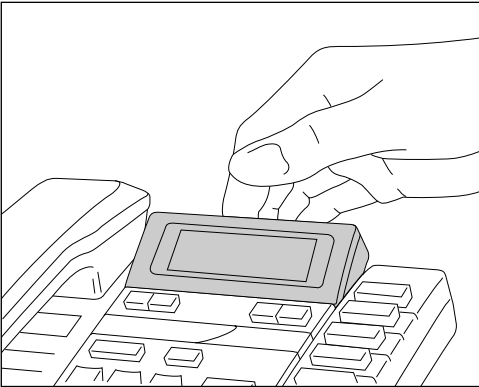

Place your 9216e on a table or hang it on a wall. Then adjust the display.



Move the sliding panel over to the right to reveal the Set Options key.

Changing the display language

For changing business requirements, you may wish to change the language of your display messages.

To change the display language:

1. Press the Set Options key.
2. Press once or press to go directly to the item.
3. Press to select the language.

Setting the date and time

If you subscribe to calling line identification service, the date and time are set automatically after you receive your first incoming call. If you don't subscribe, you must set the date and time manually.



To set the date and time:

1. Press the Set Options key.
2. Press twice or press to go directly to the item.
3. Press and follow the instructions on the display.



To resume the automatic date and time setting (if the date and time has been set manually), disconnect the power supply, then re-connect it.

Turning the ringer ON and OFF

To turn the ringer ON:

1. Press the right side of .
2. Press the right side of . Continue pressing the right hand side until you reach the desired ring volume.
3. Press .

To turn the ringer OFF:





1. Press the left side of .
2. Press the left side of . Continue pressing the left hand side until the ringer is off.
3. Press .
Ringer is OFF and the line affected appear on the display.

Note: Do not lift the handset while you are turning the ringer ON or OFF.

Setting the ring tone and ringer volume

You can choose one of four different ring tones and set the ringer volume for each line.

To set the ring tone and volume:

1. Make sure that the ringer is turned ON.
2. Press the Set Options key.
3. Press  three times or press  to go directly to the item.
4. Press  and follow the instructions on the display.
When picking the ring tone, press  to adjust the volume.
5. Press to end only when you are satisfied with ring tone and ringer volume.

Controlling the ringer volume

While the telephone is ringing, you can press the left or right side of the volume bar  for soft or loud ringer volume.

Controlling the receiver volume

While you are on the telephone, you can press the left or right side of the volume bar  for soft or loud receiver volume.

Controlling the speaker volume

While you are listening through the speaker, you can press the left or right side of the volume bar  for soft or loud speaker volume.

Callers List

Using the Callers List

The 9216e stores up to 25 calls in the Callers List. Your telephone records the number (and name if available) of the caller, when they last called, and the number of times they tried to reach you. See **Callers List display messages** for a description of the display messages.

If the telephone number of the incoming call matches a number that you have programmed with a name in a memory key, the Callers List shows that name.

You can choose to record all of your incoming calls in the Callers List or only unanswered calls.

To find items in the Callers List:

1. To see the Callers List heading, press **[Callers]**.
2. To see the first new caller in the list, press **[↓]**.
To move down and up the list, press **[↓]** or **[↑]**.
If you want to scroll steadily, press and hold **[↓]** or **[↑]**.
To see the last caller you viewed when you were last in the Callers List, press **[*]**.
To view the area code or the rest of the number whenever the arrow (→) is on the display, press **[→]**.
To cycle through the name and number screens, press **[←]** or **[→]**.
Note: You can move up and down the list in the name or number screens.
3. To leave the Callers List at any time, press **[Callers]** or **[Ris]**.
Note: If you're on a call while viewing the Callers List, pressing **[Ris]** drops the call.

Making a call from the Callers List

To dial a number in the Callers List:

1. Press **[Callers]**.
2. Find the item you want to dial out.
3. Lift the handset or press either **[Dial/Listen]**.
4. To end the call, press **[Ris]** or hang up.

If you call a number from the Callers List and you don't get connected, you may have to edit the number (for example, the number may be long distance and you may have to add "1"). See the **Editing in the Callers List** on page 11.

Editing in the Callers List

To edit a number in the Callers List:

1. Press .
2. Find the item you want to edit.
3. To see the number if you are looking at the name, press .
4. If you just want to insert digits, go to step 5. To begin editing the number, press .
5. To add digits, use the dial pad. To erase one digit to the right of the cursor, press .
- To erase one digit to the left of the cursor, press .
- Caution:** The Callers List does not save changes. If you plan to call the number again, copy it to the Directory or a memory key.
6. To dial the edited number, lift the handset then press .

To have the Callers List show local numbers without the area code and internal numbers as extensions, see **Entering area codes** on page 18.

Saving from the Callers List

To copy a number from the Callers List to the Directory or to a memory key:

1. Press .
2. Find the item you want to copy.
3. Press .
4. Press the memory key where you want to store the number.
5. If no name is displayed, you are prompted to enter one. To enter a name, use the dial pad. (See **Entering Names** on page 13.) If you don't want a name, go to step 7.
6. Press .
7. To leave the Callers List at any time, press or .

Deleting from the Callers List

To delete a number in the Callers List:

1. Press .
2. Find the item you want to delete.
3. Press twice.
You are still in the Callers List.
4. To leave the Callers List at any time,
press or .

To delete all numbers in the Callers List:

1. Press .
2. Press twice.
You are still in the Callers List.
3. To leave the Callers List at any time,
press or .

Changing the Callers List

The Callers List records up to 25 incoming calls. You can program the telephone to record unanswered calls or all incoming calls.

To change the Callers List:

1. Press the Set Options key.
2. Press seven times or press to go directly to the item.
3. Press to change the Callers List.
4. Press for all calls or press for unanswered calls.

Memory keys

Saving numbers and names in memory keys

You can save the numbers and names of your customers, business associates, or anyone you call frequently in 9216e's ten memory keys.

To save a number and name:

1. Press .
2. Press the memory key where you want to save the number.
3. Enter the number using the dial pad. You can enter a maximum of 24 digits.
Note: If you require a pause (for example, between a telephone number and an access code), press where you want the pause.
4. Press .
5. To skip the name, go to step 6. To enter a name, use the dial pad.
(See **Entering Names** below.)
6. Press .
7. Label the memory key. (See the diagram on page 14.)

Entering Names

To program a name, find the dial pad key that has the first character of the name. Keep watching the display as you press the key until that character appears on the display. Press a different dial pad key for the next character. If the next character is on the same key, press to move to the next space. To switch between upper and lower case letters, press .

For example: To enter the name **Ruth** press these keys:

, , , , .

If you wish to change a digit or letter after you have entered it, press to erase it.

, - ' & . () 1

A B C 2

D E F 3

G H I 4

J K L 5

M N O 6

P Q R S 7

T U V 8

W X Y Z 9

*

0

#

Saving from the display into memory keys

To save from the display:

1. Ensure that a number is on the display. For example, answer a call or make a call using the dial pad, Redial or the Callers List.
2. Press **Save**.
3. Press the desired memory key. If the name was displayed with the number, both are now saved in the memory key.
4. If no name is displayed, you are prompted to enter one. If you don't want a name, go to step 5. To enter a name, use the dial pad. (See **Entering Names** on page 13.)
5. Press **Save**.
6. Label the memory key. (See the diagram on page 14.)

Labeling the memory keys

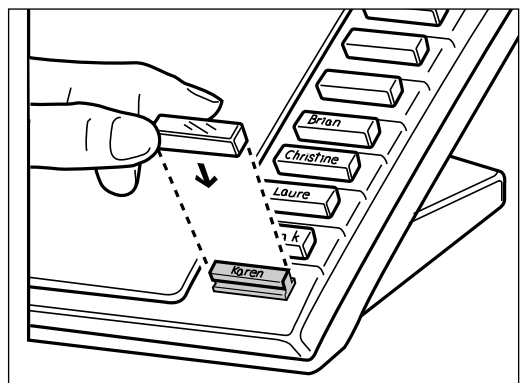
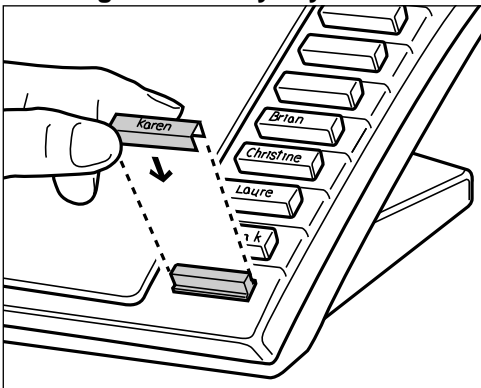

After programming the memory keys, label them with the supplied blank labels and key caps.[†]

Making calls from memory keys

To call from a memory key:

1. Lift the handset.
2. Press the memory key with the number you want to dial out.

To predial from a memory key:

1. Press the memory key with the number you want to dial out.
2. Lift the handset then press **Dial/Listen**.

[†] Keep keys caps and the sliding panel away from small children. These small parts may come off the telephone if it is dropped.

Editing memory keys

To edit a memory key:

1. To see its contents, press the memory key.
2. Press .
3. If you don't want to change the number, go to step 4. To backspace and erase digits, press . To add digits, use the dial pad.
4. Press .
5. If you don't want to change the name, go to step 6. To add letters, use the dial pad. (See **Entering Names** on page 14.) To erase letters, press .
6. Press .

Deleting memory keys

To delete a memory key:

1. To see its contents, press the memory key.
2. To erase, press twice.

Saving features in memory keys

For easy access, you can save the feature codes of telephone company services in your memory keys. This works well with network features such as Call Forwarding, Call Screen, and Call Return. Some features require an ON and OFF code in two separate keys, while other features are stored on only one key. The following procedures show you how to save both an ON and OFF code.

To save a feature ON code:

1. Press .
2. Press the memory key where you want to save the number.
3. Enter the telephone company feature code for turning the feature ON.[†]

Read the display to confirm the number.

4. Press .
5. Enter the feature name using the dial pad. (See **Entering Names** on page 13.)
6. Press .
7. Label the memory key.

To save a feature OFF code:

1. Press .
2. Press the memory key where you want to save the number.
3. Enter the telephone company feature code for turning the feature OFF.[†]

Read the display to confirm the number.

4. Press .
5. Enter the feature name using the dial pad. (See **Entering Names** on page 13.)
6. Press .
7. Label the memory key.

[†]**Note:** Contact your telephone company or Telecom manager for the appropriate feature codes.

Using feature keys

When a memory key is programmed with a feature code, you can use the memory key to activate or deactivate the feature.

To turn a feature ON or OFF:

1. Press the memory key where you stored the desired feature. The display shows the feature name and code.
2. Lift the handset, then press **[Dial/Listen]**.
The feature code is dialed out, which turns the feature ON or OFF.

Saving a feature and light in memory keys

You can make the set indicator light come ON when you turn a feature ON and go OFF when you turn that same feature OFF. You can only do this with one feature. This works well with any service that has separate ON and OFF codes such as Call Forwarding.

For example, you may want the light to remind you that you have turned Call Forwarding ON. To do this, use one key to turn the indicator light ON when you activate the feature. Use the second key to turn the indicator light OFF when you deactivate that same feature. The following procedure shows you how to program a FeatureLight ON and OFF key.

To save a FeatureLight ON key:

1. Press **[Save]**. Do NOT select a memory key yet.
2. To program the light ON, press **[1]**.
3. Press the desired memory key.
4. Enter the telephone company feature code for turning the feature ON.[†]
Read the display to confirm the number.
5. Press **[Save]**.
6. Label the memory key.
(See the diagram on page 14.)

To save a FeatureLight OFF key:

1. Press **[Save]**. Do NOT select a memory key yet.
2. To program the light OFF, press **[0]**.
3. Press the desired memory key.
4. Enter the telephone company feature code for turning the feature OFF.[†]
Read the display to confirm the number.
5. Press **[Save]**.
6. Label the memory key.
(See the diagram on page 14.)

[†]**Note:** Contact your telephone company or Telecom manager for the appropriate feature codes.

Using FeatureLight keys

To turn a feature and light ON or OFF:

1. Press the memory key where you stored the FeatureLight.
The display shows FeatureLight ON or FeatureLight OFF.
2. Lift the handset, then press **[Dial/Listen]**.
The feature and light turn ON or OFF. (When the feature and light are ON and you're not using the telephone, the display shows Feature ON and the line that it applies to as a reminder.)

Advanced Features

Adding a timer key

You can program any of the memory keys to be a timer key.

To add a timer key:

1. Press the Set Options key.
2. Press four times, or press to go directly to the item.
3. Press to add a timer key.
4. Press a memory key.
5. Press .
6. Label the timer key. (See the diagram on page 14.)

Using the Call Timer

You can program a memory key to time the length of a call. The timer starts and stops timing each call automatically.

To show the timer on the display:

1. Make or answer a call. The timer starts running automatically.
2. Once on the call, press the timer key.
The display shows the running time of the call.
3. To return to the call information display, press the timer key again.
4. When the call is over, hang up the handset or press . The timer stops counting.

Note: To show the elapsed time of the most recent call (or last call) on each line when you're not on a call, press the timer key.

Deleting a timer key

To delete a timer key

1. Press the timer key.
2. Press twice.

Entering area codes

When you enter an area code or prefix using this feature, the Callers List will show local numbers without the area code or internal Centrex numbers as extensions. This makes it easier to identify local calls and internal numbers. You can enter three separate area codes or prefixes, each up to seven digits long.

To enter area codes and prefixes:

1. Press the Set Options key.
 2. Press six times or press .
 3. Press . Enter the area code or prefix and press .
- Repeat this step for each area code or prefix you want to enter.

Display messages and lights

Knowing when you have a message

The 9216e's set indicator light lets you know that your voice mail system has a message for you. The set indicator light flashes slowly and the display shows **Message Waiting** after your voice mail has received a call. Contact your local telephone company to find out how you can subscribe to message waiting services.

Clear Message Waiting

There may be times when **Message Waiting** appears on the display when there are no more voice messages. You can turn the display message off using the Clear Message Waiting feature.

To clear message waiting:

1. Press the Set Options key.
2. Press five times, or press to go directly to the item.
3. Press to clear message waiting.

Viewing multiple display and light messages

When you aren't using the telephone, there are up to five messages that can be active at any time: date and time, **X New Callers**, **Feature ON**, **Message Waiting**, and **Ringer is OFF**. When more than one of these messages is active, the display shows the most recent message and **→** in the bottom right hand corner. You can view the other messages by pressing . You can view the other messages by pressing . Each time you press , the display shows the next active message and its associated light. You can leave any one of the active messages on the display.

Learning about the lights

The 9216e indicator light also alerts you when another extension is on the same line you're using, the telephone rings, a feature is ON or if the ringer is OFF.

Set indicator light messages

| Feature | Light |
|------------------|---|
| Call is on hold. | Set indicator light flashes quickly. |
| Extension in use | Set indicator light is ON. |
| Feature ON | Set indicator light is ON. |
| Message Waiting | Set indicator light flashes slowly. |
| Ringer is OFF | Set indicator light is OFF. |
| Visual Ringing | Set indicator light flashes very quickly. |

General display messages

| Message | What it means |
|-----------------------------------|--|
| Check line cord | If there is no dial tone, make sure the line cord and handset cord are attached securely. |
| Extension in use | An extension telephone is using the same line that you want to use. Select the other line instead. Or, someone is trying to use the same line on an extension telephone. |
| Feature ON | The FeatureLight ON key has been pressed and the code dialed out. To turn OFF the feature and the light, press the FeatureLight OFF key and lift the handset then press [Dial/Listen] . |
| <Forwarded call | The call is forwarded from another telephone. |
| Key is locked | The memory key is factory-programmed and cannot be erased or reprogrammed. Program a different memory key. |
| Long distance | The caller is calling from outside your local area. |
| Message Waiting | Your voice mail service has received a call for you. To subscribe to voice mail service contact your telephone company. |
| No information | Information from the telephone company has not been transmitted properly. |
| Private number or Private name | The caller has requested that the telephone company not deliver the number or name. |
| Ringer is OFF | The ringer volume is turned OFF. To turn the ringer ON without lifting the handset, press the right side of the volume bar. If you are in the Set Options list, press [RIS] to exit before turning the ringer ON. |
| Unknown name or Unknown number | The name or number is unavailable from the telephone company. |
| ...xxxxxxxxxxxxxxxx | The telephone number is longer than the display. The display shows ... and the last 15 digits of the number. |

Callers List display messages

| Message | What it means |
|-------------------------------|--|
| Callers List is empty | Your telephone does not record incoming calls until you subscribe to calling line identification service. If you do subscribe, you haven't received any calls in the list yet or you've deleted all numbers in the Callers List. |
| Calls bumped=xx | xx is the number of old calls automatically removed to make room for incoming new calls in the Callers List. The limit is 25 calls. |
| <Forwarded | The call is forwarded from another telephone. |
| Long dist. | The caller has called from outside your local area. Long distance dialing is required to return the call. |
| No number | You are trying to call someone in your Callers List and the number is unknown or private. |
| Private no. or Private name | The caller has requested that the telephone company not deliver the number or name. |
| Unknown name or Unknown no. | The name or number is unavailable from the telephone company. |
| X New Callers | When you're not on the telephone and not in the Callers List, the display shows you how many callers have been added to the list since you last checked it. |
| 01N xxx-xxxx | N means you have a new caller. |
| 01 ...xxxxxxxx→ | ... means the number is longer than the display or that the area code has been removed. |
| → | → means to view the rest of the number, press <input type="text"/> →. |
| 01✓ | ✓ means you have returned the call from the Callers List. |
| 01]] |] means you or an answering machine answered the call. This is only displayed when you have chosen to record all incoming calls in the Set Options List. |
| 01 R Smith Mar 04 3:30P 2x | 2x means this caller has called twice. The display shows the date and time of the last call from that caller. |

Helpful Hints

The display is in the alternate language.

You can change to the other language by pressing the Set Options key and pressing **1** twice.

There is no information on the display and the ringer volume is low.

Make sure the power adaptor is plugged in a working electrical outlet.

You cannot hear a caller or be heard.

Make sure the handset cord is inserted securely into the jack and make sure the receiver volume is high enough.

The power is out and the display is blank.

The 9216e still operates as a regular telephone during a power failure. You can dial using the dial pad and you can receive calls, but the other keys and the display do not operate until the power is restored.

The display works but you can't hear dial tone.

Your telephone lines may be wired differently from the telephone jack. To have a service person correct the wiring, contact your local telephone company or Telecom manager.

The telephone wobbles.

Check that the handset cord is placed in the channel between the stand and the telephone. See the illustration on page 3.

You cannot program a memory key.

Some of the memory keys may be factory-programmed. These keys are locked and cannot be erased or reprogrammed.

Callers are not identified on the display.

Let the telephone ring at least twice before answering. If that doesn't work, you may not have calling line identification service. To subscribe, contact your local telephone company.

The Callers List is empty.

Until you subscribe to calling line identification service, your telephone does not record incoming calls.

You cannot dial a number in the Callers List.

The caller may have an unknown number. If there is a number, you may have to edit it before you can dial it.

There is no information on the display and the ringer volume is low.

Make sure the power adaptor is connected to a working electrical outlet.

Index

A

- Area codes 18
 - entering 18

C

- Callers List 6
- Answering a call 6
 - changing 12
 - deleting a number 12
 - deleting all numbers 12
 - display messages 21
 - editing 11
 - finding items 10
 - making a call 10
 - saving 11
 - using 10
- Calls 6
 - answering 6
 - holding 6
 - making 6
 - redial list 7

D

- Date and time 8
 - automatic 8
 - setting 8
- Display language 8
 - changing 8
- Display messages 20
- Callers List 21
 - general 20

F

- FeatureLight keys
 - saving FeatureLight OFF 16
 - saving FeatureLight ON 16
 - using 16

H

- Hold
 - putting a call on hold 6
 - taking a call off hold 6

I

- Installation 3
 - connecting cords 3
 - Mounting 5

L

- Language
 - see Display language 8

M

- Memory keys 13
 - cannot program 22
 - deleting 15
 - editing 15
 - labeling 14
 - predialing from 14
 - saving a feature and light 16
 - saving features 15
 - saving from the display 14
 - saving numbers and names 13
 - using 14

R

- Redial list 7
 - making a call 7
 - using 7
- Ring tone 9
 - setting 9

T

- Timer key 17
 - adding 17
 - deleting 17
 - using 17

V

- Volume 9
 - receiver 9
 - ringer 9
 - speaker 9
 - turning the ringer off 9
 - turning the ringer on 9

General inquiries

If you have read the guide and you still have questions, call 1-800-574-1611 in Canada and the USA. In other areas, contact your telephone company.