

# N·E·A·R®



## A-Series All-Environment Loudspeaker



### Models A2, A2T

#### Features\*

- Indoor and outdoor all-weather speaker with fully-sealed cabinet
- Available versions: 8-ohm and 70V
- Available colors: black, green, and white
- Metal-alloy MDT™ mid/bass speaker cone delivers natural sound with ultra-low distortion
- Extremely stable, long-lasting MDT cone structure
- High efficiency and power handling for optimum performance
- Dual-layer voice coil with separate inner and outer windings for high output with ultra-low distortion
- Patented MLS™ fluid voice coil suspension replaces distortion-causing mechanical spider
- Compound rubber surrounds resist UV rays and salt spray
- Gold-plated, rust-proof connectors
- High-density, injection-molded cabinet resists chipping and scratching
- Low-resonance cabinet structure
- Easy-to-grasp multi-faceted mounting brackets with 180° swivel
- Easy to grip, oversized mounting knobs
- Brackets mount with knobs attached for easier and safer installation in hard-to-reach locations
- Heavy-gauge aluminum (A2 & A6 models) or stainless steel (A8 models) brackets
- Corrosion-resistant driver frame & mounting hardware
- Attractive styling with “Armadillo” ridges for stiffness
- Coaxial (A2 models) or 2-way speaker systems (A6 & A8 models)

#### Description

NEAR A-Series Armadillo® loudspeakers feature NEAR's unique technologies that improve sound quality and operating reliability. Attractively styled, they are engineered for both indoor and outdoor applications. The compact A2 models are designed for smaller spaces. Their high audio intelligibility and superb articulation make them ideal for music or paging applications. The A6 models are conveniently sized, 2-way designs with high-power handling for applications such as restaurants, health clubs, and patio and pool areas. The A8 models are high-output 2-way designs for larger spaces such as clubs, auditoriums, and theme parks. All models feature NEAR's MDT (Metal Diaphragm Technology) and MLS (Magnetic Liquid Suspension).

#### Unique MDT™ (Metal Diaphragm Technology):

- High rigidity and low mass of metal versus traditional papers and plastics
- Extremely stable cone structure over long periods of time
- Fast transmission of sound through the diaphragm means low energy storage
- Special anodizing process creates a ceramic coating for increased stiffness
- Efficient heat-sinking of voice coils under long-term, high-power situations

#### Patented MLS™ (Magnetic Liquid Suspension):

- Voice coil is constantly centered for lower distortion
- Voice coil is more efficiently heat-sunked by fluid instead of air
- Greater linearity is accomplished because the mechanical spider is eliminated
- Constant lubrication of the gap prevents oxidation from outdoor use

\*A6 and A8 models described in more detail on separate specification sheets.

Additional information at [www.nearspeakers.com](http://www.nearspeakers.com)

Specifications subject to change without notice.  
© 2000 Bogen Communications, Inc.  
Part No. 54-8008-01C 0901

## Technical Specifications

MODEL NUMBER	A2	A2T
Frequency Response (-10 dB)*	55 Hz to 20 kHz	
LF Driver	6" MDT Metal-Alloy Cone	
HF Driver	1/2" Polycarbonate	
Sensitivity (1M/1W, 8-ohm)	88 dBspl	
Impedance	8-ohm	70V
Power Handling	100W	16W
Additional Taps	-	8W, 4W
Product Weight	8 lb.	10 lb.
Cabinet Material	Mineral-Filled Polypropylene, UV-inhibited	
Speaker Dimensions	9" dia. x 8" D	
Terminations	Gold-Plated, Rust-Proof Barrier Strip	
Environmental	Meets or exceeds Mil-Std-810E	
Included Accessories	Color-Matched Aluminum Mounting Bracket	
Cabinet Color	Black, Green, White	

\* Half-Space Response

## Architect & Engineer Specifications

The loudspeaker shall be a NEAR Model A2 (8-ohm) or Model A2T (70V) in Black (BLK), White (WHT) or Green (GRN) or approved equivalent loudspeaker consisting of one 6-inch nominal low frequency transducer, one 1/2-inch nominal high frequency transducer mounted coaxially, with a filter network for dividing frequencies between the transducers. A weather-tight enclosure shall house all components. The enclosure shall be constructed from an injection-molded, high density (30% or greater), mineral-filled polypropylene material compounded with UV inhibitors.

Three molded-in colors shall be made available (Black, White, and Green). Perforated speaker grilles shall be made from heavy-gauge PVC, color-matched to the enclosure.

The low frequency driver shall utilize a metal-alloy cone with deep-anodized surface treatment for rigidity and corrosion resistance. The cone shall provide a heat transfer element for the voice coil under high power input. Compounded rubber cone surrounds shall be formulated to withstand all-environment installations, including salt spray, ultraviolet light (UV), heat, cold, and constant humidity. The voice coil will be centered via a high gauss, low viscosity magnetic fluid (ferrofluid), which increases the heat transfer rate from the voice coil under long-term, high-power use. The magnetic fluid shall prevent corrosion from occurring in the magnet gap.

The high frequency driver shall utilize an environmentally stable polycarbonate diaphragm. Ferrofluid shall dampen the voice coil and assist in the heat transfer for higher power capability.

Environmental testing shall ensure long-term operation in any weather. Specifications shall exceed Mil-Std-810E Test Methods for Temperature, Humidity, Ultraviolet Light, and Salt Spray.

The mounting bracket shall be designed with multiple angles to facilitate installation in corners or when angulation is required. An integral safety strap mounting point shall be included. The loudspeaker shall rotate, on its axis, a minimum of 180°. The bracket shall be formed from heavy-gauge aluminum (minimum 3mm thick), and finished with a scratch-resistant paint (color-matched to the enclosure).

The input connectors for 8-ohm and 70-volt systems shall be gold-plated screws with integral clamping washers.

Dimensions of each speaker shall not exceed 9" Diameter x 8" Deep. Weight shall not exceed 8 lb. (A2), and 10 lb. (A2T). The speaker shall be a NEAR Model A2 (8-ohm) or Model A2T (70V) in Black (BLK), White (WHT) or Green (GRN).

### Frequency Response

(Half-space @ 1M)

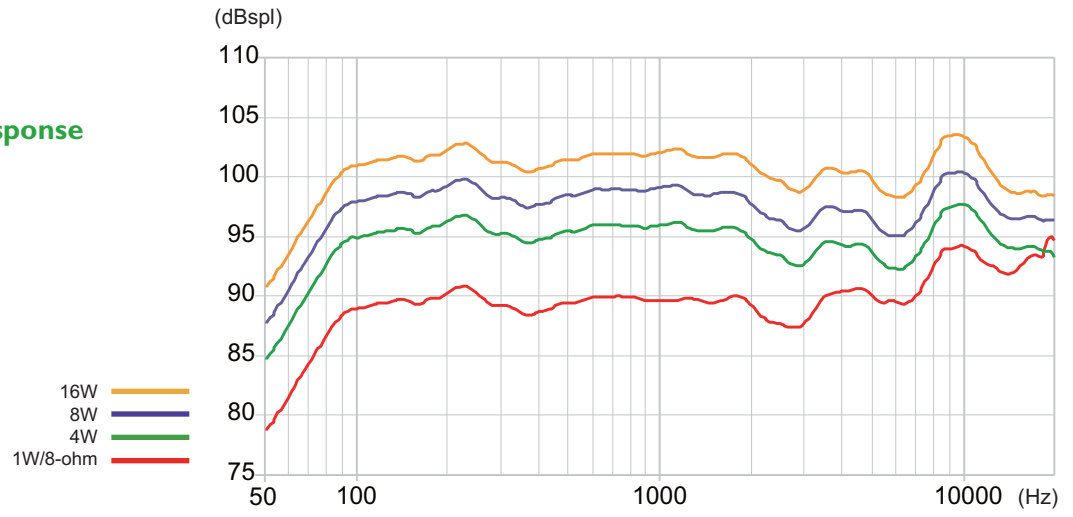

### Off-Axis Response

Because the A2 has a co-axial design, all off-axis responses are the same.

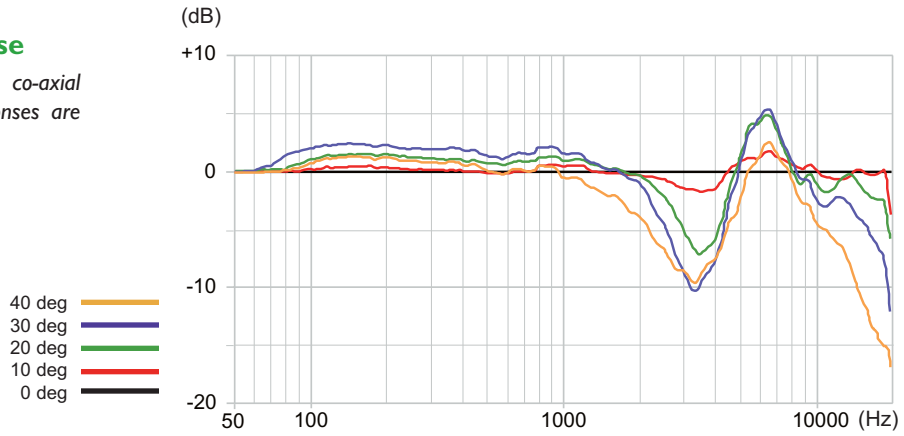

### Polar Response

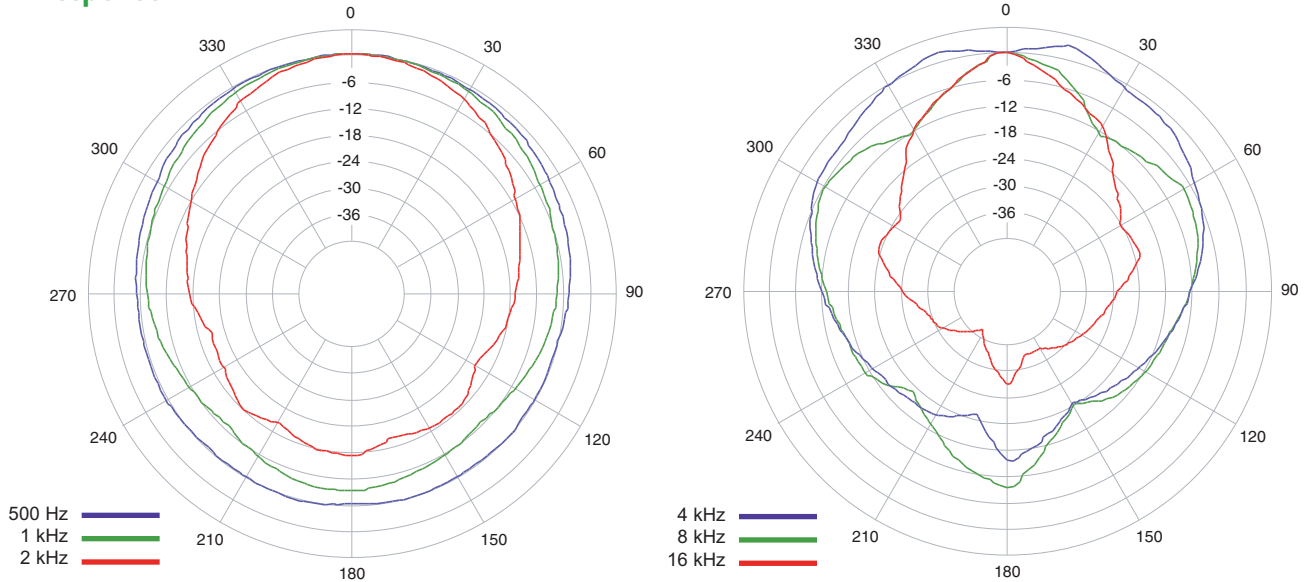

## Mechanical Drawings

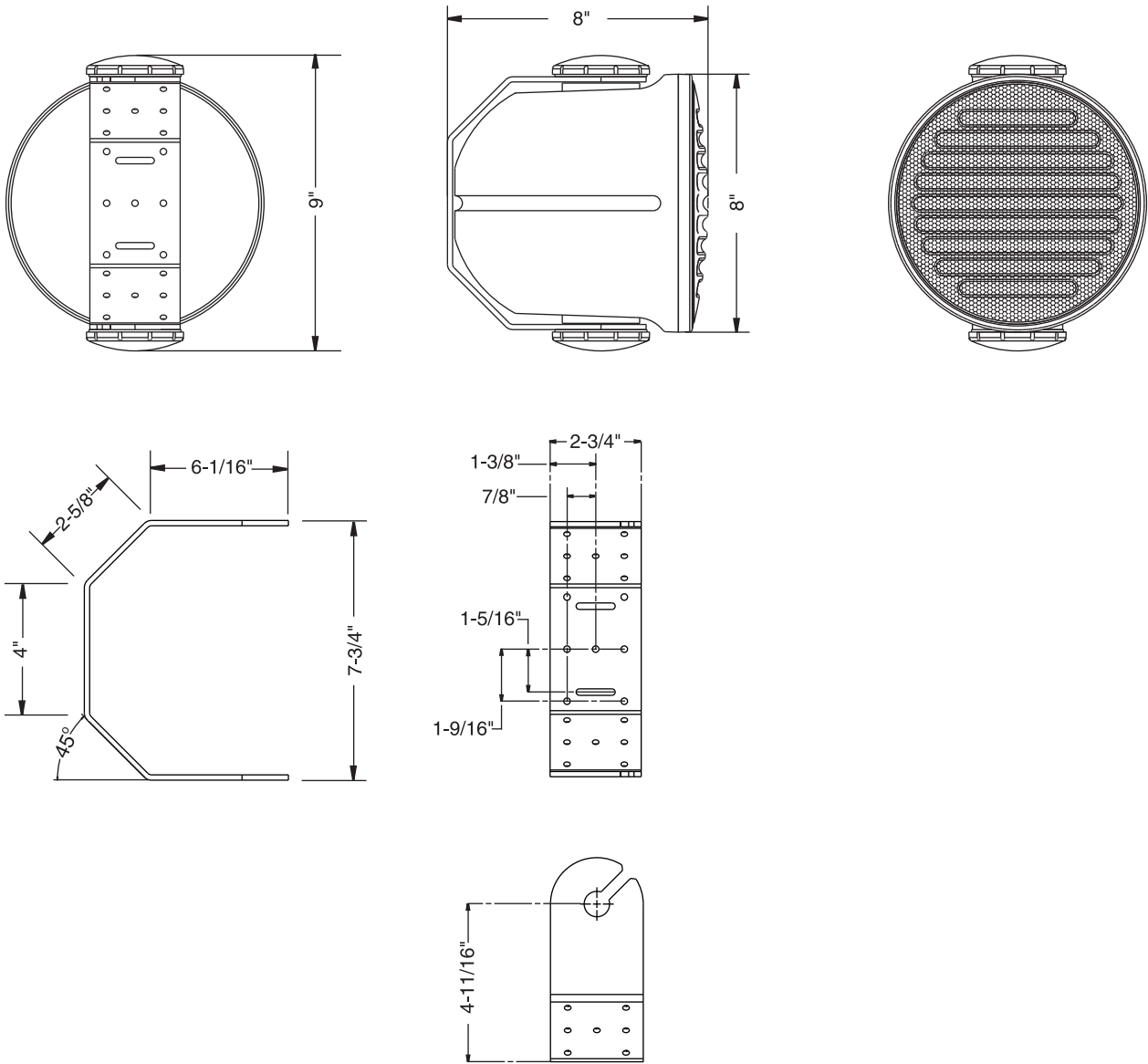

**BOGEN<sup>®</sup>**  
**COMMUNICATIONS, INC.**

50 Spring Street, Ramsey, NJ 07446, USA  
Tel: 201-934-8500 • Fax: 201-934-9832  
[www.bogen.com](http://www.bogen.com)