



# **Avaya 1165E IP Deskphone with SIP Software on Avaya Aura<sup>®</sup> User Guide**

Release 4.4  
16-604275  
Issue 01.02 Standard  
April 2016

## Notice

While reasonable efforts have been made to ensure that the information in this document is complete and accurate at the time of printing, Avaya assumes no liability for any errors. Avaya reserves the right to make changes and corrections to the information in this document without the obligation to notify any person or organization of such changes.

## Documentation disclaimer

"Documentation" means information published in varying mediums which may include product information, operating instructions and performance specifications that are generally made available to users of products. Documentation does not include marketing materials. Avaya shall not be responsible for any modifications, additions, or deletions to the original published version of Documentation unless such modifications, additions, or deletions were performed by or on the express behalf of Avaya. End User agrees to indemnify and hold harmless Avaya, Avaya's agents, servants and employees against all claims, lawsuits, demands and judgments arising out of, or in connection with, subsequent modifications, additions or deletions to this documentation, to the extent made by End User.

## Link disclaimer

Avaya is not responsible for the contents or reliability of any linked websites referenced within this site or Documentation provided by Avaya. Avaya is not responsible for the accuracy of any information, statement or content provided on these sites and does not necessarily endorse the products, services, or information described or offered within them. Avaya does not guarantee that these links will work all the time and has no control over the availability of the linked pages.

## Warranty

Avaya provides a limited warranty on Avaya hardware and software. Refer to your sales agreement to establish the terms of the limited warranty. In addition, Avaya's standard warranty language, as well as information regarding support for this product while under warranty is available to Avaya customers and other parties through the Avaya Support website: <https://support.avaya.com/helpcenter/getGenericDetails?detailId=C20091120112456651010> under the link "Warranty & Product Lifecycle" or such successor site as designated by Avaya. Please note that if You acquired the product(s) from an authorized Avaya Channel Partner outside of the United States and Canada, the warranty is provided to You by said Avaya Channel Partner and not by Avaya.

"Hosted Service" means an Avaya hosted service subscription that You acquire from either Avaya or an authorized Avaya Channel Partner (as applicable) and which is described further in Hosted SAS or other service description documentation regarding the applicable hosted service. If You purchase a Hosted Service subscription, the foregoing limited warranty may not apply but You may be entitled to support services in connection with the Hosted Service as described further in your service description documents for the applicable Hosted Service. Contact Avaya or Avaya Channel Partner (as applicable) for more information.

## Hosted Service

THE FOLLOWING APPLIES ONLY IF YOU PURCHASE AN AVAYA HOSTED SERVICE SUBSCRIPTION FROM AVAYA OR AN AVAYA CHANNEL PARTNER (AS APPLICABLE), THE TERMS OF USE FOR HOSTED SERVICES ARE AVAILABLE ON THE AVAYA WEBSITE, [HTTPS://SUPPORT.AVAYA.COM/LICENSEINFO](https://support.avaya.com/LICENSEINFO) UNDER THE LINK "Avaya Terms of Use for Hosted Services" OR SUCH SUCCESSOR SITE AS DESIGNATED BY AVAYA, AND ARE APPLICABLE TO ANYONE WHO ACCESSES OR USES THE HOSTED SERVICE. BY ACCESSING OR USING THE HOSTED SERVICE, OR AUTHORIZING OTHERS TO DO SO, YOU, ON BEHALF OF YOURSELF AND THE ENTITY FOR WHOM YOU ARE DOING SO (HEREINAFTER REFERRED TO INTERCHANGEABLY AS "YOU" AND "END USER"), AGREE TO THE TERMS OF USE. IF YOU ARE ACCEPTING THE TERMS OF USE ON BEHALF A COMPANY OR OTHER LEGAL ENTITY, YOU REPRESENT THAT YOU HAVE THE AUTHORITY TO BIND SUCH ENTITY TO THESE TERMS OF USE. IF YOU DO NOT HAVE SUCH AUTHORITY, OR

IF YOU DO NOT WISH TO ACCEPT THESE TERMS OF USE, YOU MUST NOT ACCESS OR USE THE HOSTED SERVICE OR AUTHORIZE ANYONE TO ACCESS OR USE THE HOSTED SERVICE.

## Licenses

THE SOFTWARE LICENSE TERMS AVAILABLE ON THE AVAYA WEBSITE, [HTTPS://SUPPORT.AVAYA.COM/LICENSEINFO](https://support.avaya.com/LICENSEINFO), UNDER THE LINK "AVAYA SOFTWARE LICENSE TERMS (Avaya Products)" OR SUCH SUCCESSOR SITE AS DESIGNATED BY AVAYA, ARE APPLICABLE TO ANYONE WHO DOWNLOADS, USES AND/OR INSTALLS AVAYA SOFTWARE, PURCHASED FROM AVAYA INC., ANY AVAYA AFFILIATE, OR AN AVAYA CHANNEL PARTNER (AS APPLICABLE) UNDER A COMMERCIAL AGREEMENT WITH AVAYA OR AN AVAYA CHANNEL PARTNER. UNLESS OTHERWISE AGREED TO BY AVAYA IN WRITING, AVAYA DOES NOT EXTEND THIS LICENSE IF THE SOFTWARE WAS OBTAINED FROM ANYONE OTHER THAN AVAYA, AN AVAYA AFFILIATE OR AN AVAYA CHANNEL PARTNER; AVAYA RESERVES THE RIGHT TO TAKE LEGAL ACTION AGAINST YOU AND ANYONE ELSE USING OR SELLING THE SOFTWARE WITHOUT A LICENSE. BY INSTALLING, DOWNLOADING OR USING THE SOFTWARE, OR AUTHORIZING OTHERS TO DO SO, YOU, ON BEHALF OF YOURSELF AND THE ENTITY FOR WHOM YOU ARE INSTALLING, DOWNLOADING OR USING THE SOFTWARE (HEREINAFTER REFERRED TO INTERCHANGEABLY AS "YOU" AND "END USER"), AGREE TO THESE TERMS AND CONDITIONS AND CREATE A BINDING CONTRACT BETWEEN YOU AND AVAYA INC. OR THE APPLICABLE AVAYA AFFILIATE ("AVAYA").

## License type(s)

Designated System(s) License (DS). End User may install and use each copy or an Instance of the Software only on a number of Designated Processors up to the number indicated in the order. Avaya may require the Designated Processor(s) to be identified in the order by type, serial number, feature key, Instance, location or other specific designation, or to be provided by End User to Avaya through electronic means established by Avaya specifically for this purpose.

Concurrent User License (CU). End User may install and use the Software on multiple Designated Processors or one or more Servers, so long as only the licensed number of Units are accessing and using the Software at any given time. A "Unit" means the unit on which Avaya, at its sole discretion, bases the pricing of its licenses and can be, without limitation, an agent, port or user, an e-mail or voice mail account in the name of a person or corporate function (e.g., webmaster or helpdesk), or a directory entry in the administrative database utilized by the Software that permits one user to interface with the Software. Units may be linked to a specific, identified Server or an Instance of the Software.

Database License (DL). End User may install and use each copy or an Instance of the Software on one Server or on multiple Servers provided that each of the Servers on which the Software is installed communicates with no more than one Instance of the same database.

CPU License (CP). End User may install and use each copy or Instance of the Software on a number of Servers up to the number indicated in the order provided that the performance capacity of the Server(s) does not exceed the performance capacity specified for the Software. End User may not re-install or operate the Software on Server(s) with a larger performance capacity without Avaya's prior consent and payment of an upgrade fee.

Named User License (NU). You may: (i) install and use each copy or Instance of the Software on a single Designated Processor or Server per authorized Named User (defined below); or (ii) install and use each copy or Instance of the Software on a Server so long as only authorized Named Users access and use the Software. "Named User", means a user or device that has been expressly authorized by Avaya to access and use the Software. At Avaya's sole discretion, a "Named User" may be, without limitation, designated by name, corporate function (e.g., webmaster or helpdesk), an e-mail or voice mail account in the name of a person or corporate function, or a directory entry in the administrative database utilized by the Software that permits one user to interface with the Software.

Shrinkwrap License (SR). You may install and use the Software in accordance with the terms and conditions of the applicable license agreements, such as "shrinkwrap" or "clickthrough" license accompanying or applicable to the Software ("Shrinkwrap License").

### Heritage Nortel Software

"Heritage Nortel Software" means the software that was acquired by Avaya as part of its purchase of the Nortel Enterprise Solutions Business in December 2009. The Heritage Nortel Software is the software contained within the list of Heritage Nortel Products located at <https://support.avaya.com/LicenseInfo> under the link "Heritage Nortel Products" or such successor site as designated by Avaya. For Heritage Nortel Software, Avaya grants Customer a license to use Heritage Nortel Software provided hereunder solely to the extent of the authorized activation or authorized usage level, solely for the purpose specified in the Documentation, and solely as embedded in, for execution on, or for communication with Avaya equipment. Charges for Heritage Nortel Software may be based on extent of activation or use authorized as specified in an order or invoice.

### Copyright

Except where expressly stated otherwise, no use should be made of materials on this site, the Documentation, Software, Hosted Service, or hardware provided by Avaya. All content on this site, the documentation, Hosted Service, and the product provided by Avaya including the selection, arrangement and design of the content is owned either by Avaya or its licensors and is protected by copyright and other intellectual property laws including the sui generis rights relating to the protection of databases. You may not modify, copy, reproduce, republish, upload, post, transmit or distribute in any way any content, in whole or in part, including any code and software unless expressly authorized by Avaya. Unauthorized reproduction, transmission, dissemination, storage, and or use without the express written consent of Avaya can be a criminal, as well as a civil offense under the applicable law.

### Virtualization

The following applies if the product is deployed on a virtual machine. Each product has its own ordering code and license types. Note that each Instance of a product must be separately licensed and ordered. For example, if the end user customer or Avaya Channel Partner would like to install two Instances of the same type of products, then two products of that type must be ordered.

### Third Party Components

"Third Party Components" mean certain software programs or portions thereof included in the Software or Hosted Service may contain software (including open source software) distributed under third party agreements ("Third Party Components"), which contain terms regarding the rights to use certain portions of the Software ("Third Party Terms"). As required, information regarding distributed Linux OS source code (for those products that have distributed Linux OS source code) and identifying the copyright holders of the Third Party Components and the Third Party Terms that apply is available in the products, Documentation or on Avaya's website at: <https://support.avaya.com/Copyright> or such successor site as designated by Avaya. The open source software license terms provided as Third Party Terms are consistent with the license rights granted in these Software License Terms, and may contain additional rights benefiting You, such as modification and distribution of the open source software. The Third Party Terms shall take precedence over these Software License Terms, solely with respect to the applicable Third Party Components to the extent that these Software License Terms impose greater restrictions on You than the applicable Third Party Terms.

The following applies only if the H.264 (AVC) codec is distributed with the product. THIS PRODUCT IS LICENSED UNDER THE AVC PATENT PORTFOLIO LICENSE FOR THE PERSONAL USE OF A CONSUMER OR OTHER USES IN WHICH IT DOES NOT RECEIVE REMUNERATION TO (i) ENCODE VIDEO IN COMPLIANCE WITH THE AVC STANDARD ("AVC VIDEO") AND/OR (ii) DECODE AVC VIDEO THAT WAS ENCODED BY A CONSUMER ENGAGED IN A PERSONAL ACTIVITY AND/OR WAS OBTAINED FROM A VIDEO PROVIDER LICENSED TO PROVIDE AVC VIDEO. NO LICENSE IS GRANTED OR SHALL BE IMPLIED FOR ANY OTHER USE. ADDITIONAL INFORMATION MAY BE OBTAINED FROM MPEG LA, L.L.C. SEE [HTTP://WWW.MPEGLA.COM](http://www.mpegla.com).

### Service Provider

THE FOLLOWING APPLIES TO AVAYA CHANNEL PARTNER'S HOSTING OF AVAYA PRODUCTS OR SERVICES. THE PRODUCT OR HOSTED SERVICE MAY USE THIRD PARTY COMPONENTS SUBJECT TO THIRD PARTY TERMS AND REQUIRE A SERVICE PROVIDER TO BE INDEPENDENTLY LICENSED DIRECTLY FROM THE THIRD PARTY SUPPLIER. AN AVAYA CHANNEL PARTNER'S HOSTING OF AVAYA PRODUCTS MUST BE AUTHORIZED IN WRITING BY AVAYA AND IF THOSE HOSTED PRODUCTS USE OR EMBED CERTAIN THIRD PARTY SOFTWARE, INCLUDING BUT NOT LIMITED TO MICROSOFT SOFTWARE OR CODECS, THE AVAYA CHANNEL PARTNER IS REQUIRED TO INDEPENDENTLY OBTAIN ANY APPLICABLE LICENSE AGREEMENTS, AT THE AVAYA CHANNEL PARTNER'S EXPENSE, DIRECTLY FROM THE APPLICABLE THIRD PARTY SUPPLIER.

### Compliance with Laws

You acknowledge and agree that it is Your responsibility for complying with any applicable laws and regulations, including, but not limited to laws and regulations related to call recording, data privacy, intellectual property, trade secret, fraud, and music performance rights, in the country or territory where the Avaya product is used.

### Preventing Toll Fraud

"Toll Fraud" is the unauthorized use of your telecommunications system by an unauthorized party (for example, a person who is not a corporate employee, agent, subcontractor, or is not working on your company's behalf). Be aware that there can be a risk of Toll Fraud associated with your system and that, if Toll Fraud occurs, it can result in substantial additional charges for your telecommunications services.

### Avaya Toll Fraud intervention

If you suspect that You are being victimized by Toll Fraud and You need technical assistance or support, call Technical Service Center Toll Fraud Intervention Hotline at +1-800-643-2353 for the United States and Canada. For additional support telephone numbers, see the Avaya Support website: <https://support.avaya.com> or such successor site as designated by Avaya.

### Security Vulnerabilities

Information about Avaya's security support policies can be found in the Security Policies and Support section of <https://support.avaya.com/security>.

Suspected Avaya product security vulnerabilities are handled per the Avaya Product Security Support Flow (<https://support.avaya.com/css/P8/documents/100161515>).

### Downloading Documentation

For the most current versions of Documentation, see the Avaya Support website: <https://support.avaya.com>, or such successor site as designated by Avaya.

### Contact Avaya Support

See the Avaya Support website: <https://support.avaya.com> for product or Hosted Service notices and articles, or to report a problem with your Avaya product or Hosted Service. For a list of support telephone numbers and contact addresses, go to the Avaya Support website: <https://support.avaya.com> (or such successor site as designated by Avaya), scroll to the bottom of the page, and select Contact Avaya Support.

### Trademarks

The trademarks, logos and service marks ("Marks") displayed in this site, the Documentation, Hosted Service(s), and product(s) provided by Avaya are the registered or unregistered Marks of Avaya, its affiliates, its licensors, its suppliers, or other third parties. Users are not permitted to use such Marks without prior written consent from Avaya or such third party which may own the Mark. Nothing contained in this site, the Documentation, Hosted Service(s) and product(s) should be construed as granting, by implication, estoppel, or otherwise, any license or right in and to the Marks without the express written permission of Avaya or the applicable third party.

Avaya is a registered trademark of Avaya Inc.

All non-Avaya trademarks are the property of their respective owners.  
Linux<sup>®</sup> is the registered trademark of Linus Torvalds in the U.S. and other countries.

# Contents

<b>Chapter 1: Revision history</b> .....	11
<b>Chapter 2: Regulatory and safety information</b> .....	12
<b>Chapter 3: Introduction to the Avaya 1165E IP Deskphone</b> .....	15
Basic features.....	15
Avaya 1165E IP Deskphone controls.....	16
Key press behavior.....	20
Avaya 1165E IP Deskphone display.....	21
USB support.....	21
Context-sensitive soft keys.....	22
Idle display screen after dial pad input.....	27
In-call context-sensitive soft keys.....	28
Visual indicators.....	31
Display screen icons.....	31
Visual Alerter/Message Waiting Indicators.....	33
Using a USB Mouse.....	34
Available IP Deskphone call features.....	34
Security features.....	34
Secure connection.....	35
Navigation keys.....	35
<b>Chapter 4: Installing the 1165E IP Deskphone</b> .....	37
Before you begin.....	37
<b>Connecting the components</b> .....	37
Removing the stand cover.....	39
Connecting the AC power adapter (optional).....	40
Connecting the handset.....	41
Connecting the headset (optional).....	41
Selecting the headset tuning parameter.....	41
Installing additional cables.....	42
Wall-mounting the IP Deskphone (optional).....	42
Entering text.....	45
Using the dialpad.....	45
Entering text using the USB keyboard.....	48
<b>Chapter 5: Accessing the Avaya 1165E IP Deskphone</b> .....	49
Logging on.....	49
Automatic login.....	50
Configuring the domain.....	50
Password protection for domains.....	51
Selecting a language.....	51
<b>Logging on to your Avaya IP Deskphone</b> .....	52

<b>Configuring the duration of the login</b> .....	53
Logging on multiple user accounts.....	53
Timed logoff.....	54
Timed logoff while IP Deskphone is idle.....	54
Timed logoff while on a call.....	54
Selecting a location.....	55
User Profile.....	55
Overwriting your personal Address Book.....	56
<b>Confirmation logon screen</b> .....	56
Logging off from the IP Deskphone.....	57
Logging off multiple user accounts.....	57
Making an emergency call.....	57
Location information.....	58
<b>Chapter 6: Configuring the Avaya 1165E IP Deskphone</b> .....	59
Adjusting the display screen contrast.....	59
Configuring the backlight.....	60
Creating the idle screen text display.....	60
Configuring Menu Auto back-out.....	61
Selecting a ring pattern.....	62
Adjusting the volume.....	62
Adjusting the ring volume.....	62
Adjusting the volume of the Handset, Headset, and Handsfree mode.....	63
Adjusting the paging ring volume.....	64
Selecting a language.....	65
Selecting the date and time format.....	65
USB headset.....	67
Headset menu.....	67
Presence of USB headset.....	69
Audio format selection.....	69
Generic USB headset.....	70
Avaya USB headset adapter with HID.....	70
Third-party USB headsets with HID.....	73
Analog Terminator Adapter for analog (500/2500-type) telephone or fax machine.....	75
<b>Chapter 7: Making a call</b> .....	78
Making a call using off-hook dialing.....	78
Making a call using on-hook dialing.....	79
Using handsfree calling.....	80
Using Call Subjects.....	81
Managing Call Subjects.....	82
Adding a Call Subject.....	82
Deleting a Call Subject.....	83
Editing a Call Subject.....	83
<b>Chapter 8: Receiving a call</b> .....	84

Caller identification.....	84
Answering an incoming call.....	84
Redirecting an incoming call.....	85
Ignoring an incoming call.....	86
<b>Chapter 9: The Address Book.....</b>	<b>88</b>
Viewing the Address Book.....	88
Initiating a call from the Address Book.....	88
Adding a contact to your Address Book.....	89
Editing a contact in your Address Book.....	90
Copying information to the Address Book.....	91
Searching for a contact in the Address Book.....	92
Using the Search feature in the Address Book.....	93
<b>Chapter 10: Call Inbox and Call Outbox.....</b>	<b>96</b>
Call Inbox.....	96
Accessing the Call Inbox.....	97
Managing calls in the Call Inbox while not on a call.....	97
Viewing the details of a call in the Call Inbox.....	98
Managing missed calls.....	99
Initiating a call from the Call Inbox.....	100
Deleting calls in your Call Inbox.....	101
Accessing the calls in your Call Inbox during a call.....	101
Call Outbox.....	102
Accessing the Call Outbox.....	102
Managing calls in the Call Outbox while not on a call.....	102
Accessing the calls in your Call Outbox during a call.....	104
<b>Chapter 11: Instant Messaging.....</b>	<b>105</b>
Configuring Instant Messaging.....	105
Instant Message automatic pop-ups.....	105
Configuring IM audible alert.....	106
Composing an Instant Message.....	107
Instant Message Inbox/Outbox.....	107
Accessing Instant Messages.....	108
Viewing the content of an Instant Message.....	109
Replying to an Instant Message.....	109
Initiating a call from an Instant Message.....	109
Deleting an Instant Message.....	110
<b>Chapter 12: Active calls and call features.....</b>	<b>111</b>
Group Call Pickup.....	112
Making a new call.....	112
Initiating a call using the active call soft key menu.....	113
Ring Again Busy / Automatic Callback.....	113
Whisper Page.....	114
Call Waiting.....	114

Placing a call on Hold.....	114
Multiple calls On Hold.....	115
Using 3-way calling.....	118
Ad hoc conferencing when connecting to the Call Server.....	119
Transferring a call.....	120
Using Park Call.....	121
Using the Friends feature.....	122
Accessing your Friends list.....	123
Editing information of a friend.....	124
Feature keys.....	125
Feature key programming.....	125
Remove a programmed feature key.....	130
Feature key autoprogramming.....	131
Using Call Forward.....	134
Configuring Do Not Disturb.....	136
Configuring a Presence state.....	137
Adding a new Presence state message to Presence Model v6.....	139
Audio Codecs.....	140
Audio Codec Selection.....	140
Audio Codec Ordering.....	141
PC Client softphone interworking with the IP Deskphone.....	141
Automatic remote software updates.....	142
Busy Lamp Field.....	142
Group Call Pickup.....	143
<b>Chapter 13: Advanced features.....</b>	<b>144</b>
Viewing the IP Deskphone information.....	144
Accessing the Services menu.....	145
Checking for Updates.....	146
Resetting the IP Deskphone.....	146
Erasing the user data.....	147
Network menu.....	149
USB flash drive.....	150
Customizable banner for login.....	151
Phone Information - Details screen.....	151
Screensaver/screen lock.....	152
Background image.....	155
Selecting an image screen.....	155
Service Package Group Support.....	156
Bulk-create feature keys based on an existing directory Address Book group.....	157
View existing groups in your Address Book if you selected Groups.....	158
View the existing groups you have in your Address Book.....	158
Add a new contact to your Address Book.....	159
Add a new group.....	160



Speed Dial List.....	160
Speed Dial List screen.....	161
Auto-Retrieve flag.....	162
USB flash memory device support.....	162
File Manager.....	164
USB scenarios.....	165
Announcement Record / Listen.....	166
Abbreviated Dialing Lists.....	166
Change Class of Restriction .....	167
Change Coverage .....	167
EC500 Self Administration.....	167
Malicious Call Trace Activation.....	168
Station Lock and Unlock.....	168
<b>Chapter 14: Multiuser.....</b>	<b>169</b>
Initial login.....	169
Additional logins.....	170
Automatic login.....	170
Logging out.....	171
Primary account logout.....	171
Secondary account logout.....	171
Server failover.....	171
Cable unplugged.....	172
Upgrade impacts to user profiles.....	172
Line keys.....	173
Making a call.....	174
Receiving a call.....	175
Being in a call.....	175
Instant Messages.....	176
Menu features.....	176
Modifying settings.....	176
Per-account call notification options.....	177
IM Settings.....	177
Voice Mail Settings.....	177
Remembering settings after logout.....	177
Programmable keys.....	178
Inbox, Outbox, IM log.....	178
Address books.....	179
User status.....	179
Do Not Disturb.....	180
Presence.....	180
Call Forwarding.....	181
Notifications.....	182
Account selection.....	183

Contents

Receiving a call..... 183

# Chapter 1: Revision history

<b>May 2016</b>	Standard 01.02. Updated to describe the differences between Presence Models v6 and v7, and to update the display screen icons for Presence.
<b>November 2013</b>	Standard 01.01. This is a new document created to support SIP Software Release 4.4 on Avaya Aura®.

# Chapter 2: Regulatory and safety information

This equipment has been tested and found to comply with the limits for a Class B digital device, pursuant to part 15 of the FCC Rules. These limits are designed to provide reasonable protection against harmful interference in a residential installation. This equipment generates, uses and can radiate radio frequency energy and, if not installed and used in accordance with the instructions, may cause harmful interference to radio communications. However, there is no guarantee that interference will not occur in a particular installation. If this equipment does cause harmful interference to radio or television reception, which can be determined by turning the equipment off and on, the user is encouraged to try to correct the interference by one or more of the following measures:

- Reorient or relocate the receiving antenna.
- Increase the separation between the equipment and receiver.
- Connect the equipment into an outlet on a circuit different from that to which the receiver is connected.
- Consult the dealer or an experienced radio/TV technician for help.

**\* Note:**

The user should not make changes or modifications not expressly approved by Avaya. Any such changes could void the user authority to operate the equipment

This Class B digital apparatus complies with Canadian ICES-003. Cet appareil numérique de la classe B est conforme à la norme NMB-003 du Canada.

**Warning:**

- This is a Class B product. In a domestic environment this product can cause radio interference in which case the user must take adequate measures.
- Operation is subject to the following two conditions: (1) this device may not cause interference, and (2) this device must accept any interference, including interference that may cause undesired operation of the device.

この装置は、情報処理装置等電波障害自主規制協議会（VCCI）の基準に基づくクラスB情報技術装置です。この装置は、家庭環境で使用することを目的としていますが、この装置がラジオやテレビジョン受信機に近接して使用されると、受信障害を引き起こすことがあります。

取扱説明書に従って正しい取り扱いをして下さい。

**Table 1: EMC Compliance**

Jurisdiction	Standard	Description
United States	FCC CFR 47 Part 15	Class B Emissions: FCC Rules for Radio Frequency Devices (see Notes 1 and 2)
Canada	ICES-003	Class B Emissions: Interference-Causing Equipment Standard: Digital Apparatus
Australia/New Zealand	AS/NZ CISPR 22 CISPR 22	Class B Emissions: Information technology equipment - Radio disturbance
European Community	EN 55022	Class B Emissions: Information technology equipment - Radio disturbance
	EN 55024	Information technology equipment - Immunity characteristics Limits and methods of measurement
	EN 61000-3-2	Limits for harmonic current emissions (equipment input current <= 16 A per phase)
	EN 61000-3-3	Limitation of voltage fluctuations and flicker in low-voltage supply systems for equipment with rated current <= 16 A
Japan	VCCI	Regulations for voluntary control measures.

**Table 2: Safety Compliance**

Jurisdiction	Standard	Description
United States	UL 60950-1	Safety of Information Technology Equipment
Canada	CSA 60950-1-30	Safety of Information Technology Equipment
Australia/New Zealand	AS/NZS 60950.1:2003	Safety of Information Technology Equipment
European Community	EN 60950-1	ITE equipment - Safety - Part 1: General requirements

**Other**

**US/Canada:** Hearing Aid Compatibility (HAC) as per FCC Part 68 Australia: AS/ACIF S004: Voice Frequency Performance Requirements for Customer Equipment This equipment complies with the CE Marking requirements.

**EU Countries:** This device complies with the essential requirements and other relevant provisions of Directive 1999/5/EC. A copy of the Declaration may be obtained from [HTTP://SUPPORT.AVAYA.COM/CSS/APPMANAGER/PUBLIC/SUPPORT](http://SUPPORT.AVAYA.COM/CSS/APPMANAGER/PUBLIC/SUPPORT).

**Australia: AS/ACIF S004:** Voice Frequency Performance Requirements for Customer Equipment.

## DenAn regulatory notice for Japan

### Warning:

Please be careful of the following while installing the equipment:



- Please only use the connecting cables, power cord, AC adaptors shipped with the equipment or specified by Avaya to be used with the equipment. If you use any other equipment, it may cause “failures, malfunctioning, or fire”.
- Power cords shipped with this equipment must not be used with any other equipment. If the above guidelines are not followed, it may lead to death or severe injury.



本製品を安全にご使用頂くため、以下のことにご注意ください。

- 接続ケーブル、電源コード、ACアダプタなどの部品は、必ず製品に同梱されております。添付品または指定品をご使用ください。添付品・指定品以外の部品をご使用になると故障や動作不良、火災の原因となることがあります。
- 同梱されております付属の電源コードを他の機器には使用しないでください。  
上記注意事項を守らないと、死亡や大怪我など人身事故の原因となることがあります。

# Chapter 3: Introduction to the Avaya 1165E IP Deskphone

The Avaya 1165E IP Deskphone builds on the award-winning Avaya 1100 Series IP Deskphones industrial design and offers a high resolution color display and new graphical user interface elements that enhance the user experience. The Avaya 1165E IP Deskphone provides easy access to multiple lines and call processing features.

Experience the display capabilities by personalizing the background image of the Avaya 1165E IP Deskphone display, and loading digital pictures into the IP Deskphone to view a Digital Picture Slideshow when the IP Deskphone is idle. The audio experience is enhanced through engineered audio tuning, and supports wideband (see Note) with a newly-stylized handset that has been softly contoured for additional comfort when using the handset.

 **Note:**

Wideband has dependencies on Avaya Communication Platform support and is minimum-release dependent.

## Related links

- [Basic features](#) on page 15
- [Avaya 1165E IP Deskphone controls](#) on page 16
- [Avaya 1165E IP Deskphone display](#) on page 21
- [USB support](#) on page 21
- [Context-sensitive soft keys](#) on page 22
- [Visual indicators](#) on page 31
- [Using a USB Mouse](#) on page 34
- [Available IP Deskphone call features](#) on page 34
- [Security features](#) on page 34
- [Navigation keys](#) on page 35

---

## Basic features

Your Avaya 1165E IP Deskphone supports the following features:

- up to sixteen line/feature keys with indicators using the Shift feature
- four soft keys to provide easy access to features and call control
- high resolution color display

- high-quality handsfree speakerphone
- wideband audio support for handset, headset, speaker, and handsfree microphone
- volume control keys for adjusting ringer, handsfree, handset, and headset volume
- seven specialized feature keys:
  - Quit
  - Directory
  - Message/Inbox
  - Shift/Outbox
  - Services
  - Copy
  - Expand
- five call-handling keys:
  - Mute
  - Handsfree
  - Goodbye
  - Headset
  - Hold
- two Gigabit Ethernet ports—for LAN and PC connections
- integrated headset support for wired and wireless options including USB and Bluetooth Wireless Technology
- IEEE 802.3af PoE or local AC power options
- hearing aid compatibility
- USB port for connecting a USB keyboard, USB mouse, USB headset, USB flash drive and powered hubs
- USB access control (USB lock) that controls how the USB port on the Avaya 1165E IP Deskphone can be used

For more information about using the Expansion Module, see the Avaya 1100 Series Expansion Module User Guide (NN43130-101).

#### Related links

[Introduction to the Avaya 1165E IP Deskphone](#) on page 15

---

## Avaya 1165E IP Deskphone controls

The following image shows the Avaya 1165E IP Deskphone.


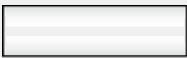
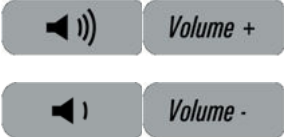





\* If supported by your server, the Feature Status Lamp provides a user-defined alert. Contact your system administrator to find out if this feature is available for you.

**Figure 1: Avaya 1165E IP Deskphone**

This section describes the controls on your Avaya 1165E IP Deskphone. Your Avaya 1165E IP Deskphone can have fixed keys with icons or with labels. This document presents both versions of the fixed key.

Key	Function
	<p>The keys on either side of the LCD display area are <b>Self-labeled Line/Programmable feature keys</b> with labels on the LCD. The system administrator can reserve some keys for specific functions during tasks and for advanced configuration.</p> <p>You can define these keys for specific functions, such as Call Forward.</p> <p><b>Note:</b> The key on the lower right is reserved as your default line key.</p>
	<p><b>Context-sensitive soft keys</b> are located below the display area. The LCD label above each key changes based on the active feature.</p>
	<p>Use the <b>Volume control</b> buttons to adjust the volume of the ringer, handset, headset, speaker, and the Handsfree feature. Press the top button to increase the volume, and press the bottom button to decrease the volume.</p>
	<p>Press the <b>Mute</b> key to listen to the call without transmitting. Press the Mute key again to return to two-way conversation.</p>

*Table continues...*

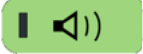





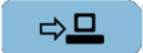










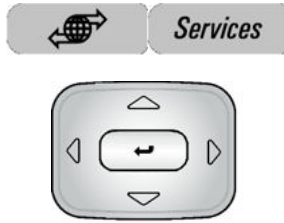




Key	Function
	<p>The Mute key applies to handsfree, handset, and headset microphones.</p> <p><b>Note:</b> When you enable mute, a red LED on the <b>Mute</b> key remains lit.</p>
 	<p>Press the <b>Handsfree</b> key to activate the built-in speaker and microphone of the IP Deskphone.</p> <p><b>Note:</b> The Handsfree LED indicator on the <b>Handsfree</b> key lights to indicate when handsfree is active.</p>
	<p>Use the <b>Navigation Key Cluster</b> to scroll through menus and lists that appear on the LCD display screen or for text entry. The outer part of this key cluster rocks for up, down, left, and right movements. For more information, see <a href="#">Navigation keys</a> on page 35.</p>
	<p>Use the <b>Enter</b> key, at the center of the Navigation Key Cluster, to select menu items or to confirm changes.</p> <p><b>Note:</b> The <b>Enter</b> key has the same function as the context-sensitive soft keys <b>Select</b> and <b>Set</b>.</p>
 	<p>Press the <b>Goodbye/Release</b> key to terminate an active call. When multiple calls are active, press the <b>Goodbye/Release</b> key to end the highlighted call.</p> <p>Use the <b>Goodbye/Release</b> to close menu navigation or cancel user tasks.</p>
 	<p>Press the <b>Expand</b> key to access the Instant Messaging Log.</p> <p><b>Note:</b> This feature requires an External Application Server.</p>
 	<p>Press the <b>Headset</b> key to answer a call using the headset or to switch a call from the handset or handsfree to the headset.</p> <p><b>Note:</b> The <b>Headset</b> LED indicator on the Headset key lights to indicate that the headset is in use.</p> <p>If the Bluetooth wireless technology is not enabled on your IP Deskphone, this menu is not available.</p>
 	<p>Press the <b>Hold</b> key to put an active call on hold. Press the <b>Hold</b> fixed key to return to a call on hold. You can have several calls in a hold state.</p>
	<p>Use the <b>Dialpad</b> to enter numbers and text. To navigate to an item in a menu, press the corresponding number on the dialpad to activate the item or continue navigate the list of items.</p>

Table continues...

Key	Function
	<p>When you receive a voice message, the red <b>Visual Alerter/Message Waiting Indicator</b> lights. Also, when the ringer sounds, this indicator flashes.</p>
	<p>When your Avaya 1165E IP Deskphone firmware is being updated, the blue <b>Feature Status Lamp</b> indicator flashes.</p> <p>To find out if additional features are supported for this lamp, contact your administrator.</p>
	<p>Press the <b>Copy</b> key to copy contact information from one source such as the Address Book to a destination such as a feature key.</p>
	<p>Press the <b>Services</b> key, and then use the navigation keys to access the following items:</p> <ol style="list-style-type: none"> <li>1. Search—search in the local directory (personal Address Book) and the global directory (network Address Book for names and telephone numbers)</li> <li>2. Login—log in to your IP Deskphone only when the call server supports multiple user logins.</li> <li>3. Logout—log out of your IP Deskphone.</li> <li>4. Check For Updates—check for the latest software and configuration update for the IP Deskphone.</li> <li>5. Retrieve Parked Call (This feature is not available on all call servers.)</li> <li>6. Reset Phone—reset your IP Deskphone.</li> <li>7. File Manager—manage the IP Deskphone file system and USB Devices attached to the IP Deskphone.</li> <li>8. Logging System—enable or disable the logging process.</li> <li>9. Phone Information—view information about the hardware and software on your IP Deskphone, including user and location information.</li> </ol>
	
	<p>Press the <b>Quit</b> key to cancel the current operation or to exit the menu.</p> <p><b>Note:</b> Pressing the <b>Quit</b> key does not affect the status of active calls.</p>

*Table continues...*

Key	Function
 <b>Msg/Inbox</b>	Press the <b>Inbox</b> key to access your call inbox. The call inbox lists all incoming calls on an active IP Deskphone. <b>Note:</b> This key does not function to send Instant Messages.
 <b>Shift/Outbox</b>	Press the <b>Shift/Outbox</b> key to access your call outbox.
 <b>Directory</b>	Press the <b>Directory</b> key to access the Address Book and the Friends list. <b>Note:</b> You can access the Address Book while on a call and start a new call with a highlighted contact.

### Related links

- [Introduction to the Avaya 1165E IP Deskphone](#) on page 15
- [Key press behavior](#) on page 20

## Key press behavior

The behavior of the IP Deskphone when you press a fixed key is as follows.

### Goodbye/Release, Mute, Hold, Headset, Handsfree and Hookswitch

If there is an active established call, the key action applies to this active call.

If there is no active call, the key action is applied to the call that is highlighted in the list of calls.

#### \* Note:

Some actions may be ignored in certain conditions; for example:

- pressing the Goodbye/Release key for a call on local hold
- pressing the Hold key for an incoming call

### Line key

If there is an incoming call, and you press the Line key, the incoming call is answered.

If there is an active call, and you press the Line key, the Line key press is ignored.

If there are no incoming or active calls, the Line key press is applied to the call that is highlighted in the list of calls.

If there is an active established call and at the same time another call comes in, pressing the Line key puts the active call on hold and answers the incoming call.

If there are several incoming calls at the same time, the newest call is answered. In order to answer a different call, you must select it and press the corresponding soft key.

Soft keys are always used to perform actions on the highlighted call.

### Related links

- [Avaya 1165E IP Deskphone controls](#) on page 16

---

## Avaya 1165E IP Deskphone display

Your Avaya 1165E IP Deskphone has three display areas:

- The upper display area provides line and feature key status.
- The middle display area contains single-line information for items such as caller number, caller name, menu items, feature prompt strings, user-entered digits, date and time information, and telephone information.
- The lower display area provides context-sensitive soft key label information.

Self-labeled line/programmable feature key labels appear beside the line keys, and context-sensitive soft key labels appear directly above the soft keys. Self-labeled means that the label next to the line/feature key is presented from the call server automatically if a feature is programmed, and can also be edited and changed by the user. Context-sensitive means that the labels that appear above the soft keys present the features that are available to the user at that time. The soft key labels change depending on the active feature or the state of the call.

Self-labeled line/programmable feature keys are referred to as line/feature keys and context-sensitive soft keys are referred to as soft keys throughout this document.

### Related links

[Introduction to the Avaya 1165E IP Deskphone](#) on page 15

---

## USB support

The 1165E IP Deskphone has a USB port for connecting a USB keyboard, USB mouse, USB headset, and USB flash drive. The 1165E IP Deskphone supports powered downstream 1.1-compliant USB hubs, including USB 2.0 hubs, if they offer USB 1.1-backwards compliancy.

There are two levels of power for the USB port.

- When you power the 1165E IP Deskphone through Ethernet POE, the 1165E IP Deskphone provides up to 100 mA at 5 volts for the USB port.
- When you power the 1165E IP Deskphone through local AC power, the 1165E IP Deskphone provides up to 500 mA at 5 volts on the USB port.

 **Note:**

Current limiting can obstruct the working of complex devices such as USB keyboards with built-in hubs. If a hub is involved, use external power.

You can plug a USB flash drive into the USB Port of the 1165E IP Deskphone or on a powered hub connected to the IP Deskphone, and transfer files to and from the IP Deskphone.

### Related links

[Introduction to the Avaya 1165E IP Deskphone](#) on page 15

## Context-sensitive soft keys

Your Avaya 1165E IP Deskphone has four context-sensitive soft keys beneath the LCD screen. The context-sensitive soft keys access different features and menus depending on the state of the IP Deskphone and the menu you access.

**\* Note:**

Not all the following soft keys may be displayed (for example, Retrve, ScrnSvr), depending on what is configured and available on your system and IP Deskphone.

The following figure shows the soft keys while the 1165E IP Deskphone is in the idle state.

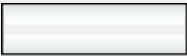
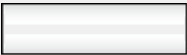






**Figure 2: Context-sensitive soft keys when the IP Deskphone is in the idle state**

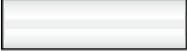
**Table 3: Menu items accessed through context-sensitive soft keys**

Item	Function
<p style="text-align: center;"><b>Redial or NewCall</b></p> <div style="text-align: center; border: 1px solid black; width: 100px; height: 20px; margin: 0 auto;"></div>	<p>Press the <b>Redial</b> context-sensitive soft key to redial the last dialed number.</p> <p>If there is no stored redial number, the <b>NewCall</b> context-sensitive soft key appears and has the same effect as pressing the primary user line key (dial prompt).</p>
<p style="text-align: center;"><b>abc or 123</b></p> <div style="text-align: center; border: 1px solid black; width: 100px; height: 20px; margin: 0 auto;"></div>	<p>Press the <b>abc</b> context-sensitive soft key to toggle between alpha and numeric input modes.</p> <ul style="list-style-type: none"> <li>• To type letters, the <b>abc</b> context-sensitive soft key must be displayed.</li> <li>• To type numbers, press the <b>abc</b> context-sensitive soft key to display the <b>123</b> context-sensitive soft key on the menu list.</li> </ul>
<p style="text-align: center;"><b>Msgs</b></p> <div style="text-align: center; border: 1px solid black; width: 100px; height: 20px; margin: 0 auto;"></div>	<p>Press the <b>Msgs</b> context-sensitive soft key to access the following features:</p> <ol style="list-style-type: none"> <li>1. Voice Mail—use to call your Voice Mail number.</li> <li>2. Instant Messaging—use to access the Instant Messaging Inbox/Outbox.</li> <li>3. Missed Call Notification—use to access your Missed Call details.</li> </ol>

*Table continues...*

Item	Function
<p style="text-align: center;"><b>More...</b></p> 	<p>Press the <b>More...</b> context-sensitive soft key to select a new menu list of context-sensitive soft keys (three menu lists are available). When you press the <b>More...</b> context-sensitive soft key, a different selection of context-sensitive soft keys appears.</p> <ul style="list-style-type: none"> <li>• If you press the <b>More...</b> context-sensitive soft key once from the first menu list, you access the following context-sensitive soft keys: [CallFwd] [DND] [Presnce] [More...]</li> <li>• If you press the <b>More...</b> context-sensitive soft key from the first menu list twice, you access the following context-sensitive soft keys: [ScrnSvr] [Prefs] [&lt;blank&gt;] [More...]</li> <li>• If you press the <b>More...</b> context-sensitive soft key from the first menu list three times, you return to the first menu list with the following context-sensitive soft keys. [Redial] [abc] [Msgs] [More...]</li> </ul>
<p><i>When you press the <b>More...</b> context-sensitive soft key for the first time, the following context-sensitive soft keys appear on the menu list.</i></p>	
<p style="text-align: center;"><b>CallFwd</b></p> 	<p>Press the <b>CallFwd</b> context-sensitive soft key to forward all calls to a specified address.</p>
<p style="text-align: center;"><b>DND</b></p> 	<p>Press the <b>DND</b> context-sensitive soft key to block all calls.</p>
<p style="text-align: center;"><b>Presnce</b></p> 	<p>Press the <b>Presnce</b> context-sensitive soft key to configure the presence status for your IP Deskphone.</p>
<p style="text-align: center;"><b>More...</b></p> 	<p>Press the <b>More...</b> context-sensitive soft key to select a new menu list of context-sensitive soft keys.</p> <p>The next available menu list contains the following context-sensitive soft keys: [ScrnSvr] [Prefs] [&lt;blank&gt;] [More...]</p>
<p><i>When you press the <b>More...</b> context-sensitive soft key for the second time, the following context-sensitive soft keys appear on the menu list.</i></p>	
<p style="text-align: center;"><b>ScrnSvr</b></p> 	<p>Press the <b>ScrnSvr</b> context-sensitive soft key to activate the screensaver (only if the screensaver feature is enabled).</p>
<p style="text-align: center;"><b>Prefs</b></p>	<p>Press the <b>Prefs</b> context-sensitive soft key to display the Preferences menu.</p>

*Table continues...*


Item	Function
	<p>The menu items include the following:</p> <ol style="list-style-type: none"> <li>1. Display—use to adjust the display settings of the LCD screen.</li> <li>2. Audio—use to adjust tones and volume settings, access the Codecs menu to configure a USB headset.</li> </ol> <p>Press the <b>Audio</b> context-sensitive soft key to access the following features:</p> <p><b>Tones</b></p> <ul style="list-style-type: none"> <li>• Ring Pattern             <ul style="list-style-type: none"> <li>- Select test patterns from 1 to 8</li> </ul> </li> <li>• Alerting Volume             <ul style="list-style-type: none"> <li>- Set Desired volume</li> </ul> </li> </ul> <p><b>Voice</b></p> <p>Configure the volume for the following:</p> <ul style="list-style-type: none"> <li>• Handset Volume</li> <li>• Headset Volume</li> <li>• Handsfree Volume</li> </ul> <p><b>Codecs</b></p> <p>Select the Audio Codecs:</p> <ul style="list-style-type: none"> <li>• G722 (wideband codec)</li> <li>• PCMU (standard u-law)</li> <li>• G729 (729 codec)</li> <li>• PCMA (standard a-law)</li> </ul> <p><b>Headset Selection</b></p> <p>Select the active headset device:</p> <ul style="list-style-type: none"> <li>• Wired, USB (if wired, then select type 1, 2 or 3)</li> <li>• Enable HID Commands (enable or disable)</li> <li>• MHA Headset Type</li> <li>• MHA Back Light (enable or disable)</li> </ul> <p><b>Note:</b> You can change the audio settings to improve audio quality based on the available band width. If the Internet bandwidth is low,</p>

*Table continues...*



Item	Function
	<p>you can improve the audio quality by changing the audio setting to low.</p> <p><b>Monitor Audio Quality</b></p> <p>Monitor Audio Quality—used to view details about the audio quality of an active call.</p> <p><b>Bluetooth Setup</b></p> <ul style="list-style-type: none"> <li>• Enable Bluetooth (enable or disable)</li> <li>• To unpair Device select UnPair.</li> </ul> <p>If Bluetooth is enabled, select:</p> <ul style="list-style-type: none"> <li>• Search devices (phone searches the bluetooth devices and lists the discovered devices in the Found field.</li> <li>• To set an Active device select Set.</li> <li>• To pair with a found device select Pair.</li> <li>• To unpair Device select UnPair.</li> </ul> <p><b>Note:</b> You can change the audio settings to improve audio quality based on the available band width. If the Internet bandwidth is low, you can improve the audio quality by changing the audio setting to low.</p> <p>3. Feature Options—use to configure the following:</p> <ul style="list-style-type: none"> <li>• Feature keys</li> <li>• Call Ignore Action</li> <li>• Call Subjects</li> <li>• Call Fwd Notification</li> <li>• Missed Call Notification</li> <li>• Answer Mode Settings appear when the Auto Answer Mode is enabled on the IP Deskphone.</li> </ul> <p>4. Language—use to change the interface language.</p> <p>5. Misc Options—use to access the following options:</p> <ul style="list-style-type: none"> <li>• Alpha Dialing</li> <li>• Search Method</li> <li>• Incoming Privacy</li> </ul>

*Table continues...*

Item	Function
	<ul style="list-style-type: none"> <li>• Outgoing Privacy</li> <li>• # Ends Dialing</li> <li>• Hold Mode: Private</li> <li>• Time</li> </ul> <p>6. Network—use to access the following:</p> <ul style="list-style-type: none"> <li>• Server Settings</li> <li>• Device Settings</li> <li>• Diagnostics</li> <li>• Disable screensaver</li> <li>• Licensing</li> <li>• Lock</li> </ul> <p>7. USB Locks—use to lock or unlock the following USB devices:</p> <ul style="list-style-type: none"> <li>• USB Mouse</li> <li>• USB Keyboard</li> <li>• USB Headset</li> <li>• USB flash drive</li> </ul> <p>8. User Settings - use to modify the following:</p> <ul style="list-style-type: none"> <li>• Call Settings</li> <li>• IM Settings</li> <li>• Voice Mail Settings</li> <li>• Change Location</li> </ul>
(blank)	No soft key label.
<p><b>More...</b></p> 	<p>Press the <b>More...</b> context-sensitive soft key to return to the first menu list of context-sensitive soft keys.</p> <p>The next available menu list contains the following context-sensitive soft keys: [Redial] [abc] [Msgs] [More...]</p>

**Related links**

[Introduction to the Avaya 1165E IP Deskphone](#) on page 15

[Idle display screen after dial pad input](#) on page 27

[In-call context-sensitive soft keys](#) on page 28

## Idle display screen after dial pad input

After you enter information using the dial pad (there is no dial tone or preceding line selection), the context-sensitive soft keys displayed on the idle screen appear as shown in the following figure.

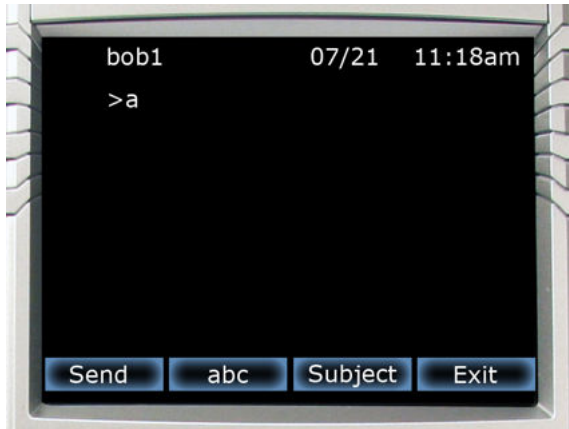

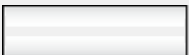




Figure 3: Idle display screen after dial pad input

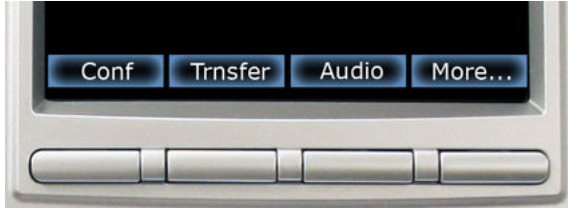
Item	Function
<p><b>Send</b></p> 	<p>Press the <b>Send</b> context-sensitive soft key to dial out the user input using the primary login of the IP Deskphone.</p> <p>User input is run against the dialing plan.</p>
<p><b>abc or 123</b></p> 	<p>Press the <b>abc</b> or <b>123</b> context-sensitive soft key to toggle between alpha and numeric input mode.</p>
<p><b>Subject</b></p> 	<p>Press the <b>Subject</b> context-sensitive soft key to configure a subject line to your outgoing call before pressing the <b>Send</b> context-sensitive soft key.</p>
<p><b>Exit</b></p> 	<p>Press the <b>Exit</b> context-sensitive soft key to clear the user input and return to the initial idle screen that displays the following context-sensitive soft keys:</p> <p>[Redial] [abc] [Msgs] [More...].</p> <p>See <a href="#">Context-sensitive soft keys</a> on page 22.</p>

### Related links

[Context-sensitive soft keys](#) on page 22


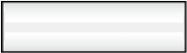

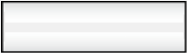
## In-call context-sensitive soft keys

When a call is active, use the context-sensitive soft keys to access the menu items shown in the following figure.



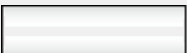


**Figure 4: In-call context-sensitive soft keys**

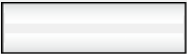


**Table 4: Menu items accessed during an in-call session through context-sensitive soft keys**

Item	Function
<p style="text-align: center;"><b>Conf</b></p> <div style="text-align: center;">  </div>	<p>Press the <b>Conf</b> context-sensitive soft key to obtain a dial tone to place another call during an active call or to make a conference call.</p> <p>The <b>Conf</b> context-sensitive soft key behaves like the <b>NewCall</b> context-sensitive soft key.</p>
<p style="text-align: center;"><b>Trnsfer</b></p> <div style="text-align: center;">  </div>	<p>Press the <b>Trnsfer</b> context-sensitive soft key to transfer the current call to another location or to another contact.</p>
<p style="text-align: center;"><b>Audio</b></p> <div style="text-align: center;">  </div>	<p>Press the <b>Audio</b> context-sensitive soft key to access the following features:</p> <ol style="list-style-type: none"> <li>1. Change Audio Codec                             <ul style="list-style-type: none"> <li>• G722 (wideband codec)</li> <li>• PCMU (standard u-law)</li> <li>• G729 (729 codec)</li> <li>• PCMA (standard a-law)</li> </ul> </li> <li>2. Monitor Audio Quality—used to view details about the audio quality of an active call</li> </ol>
<p style="text-align: center;"><b>Activate</b></p> <div style="text-align: center;">  </div>	<p>The <b>Activate</b> context-sensitive soft key appears when the call is not active. The most common usage of this key is when the call displayed onscreen is a call that was parked against the user (or a call that the user placed on hold).</p> <p><b>Note:</b> The <b>Activate</b> context-sensitive soft key never appears at the same time as the <b>Audio</b> context-sensitive soft key.</p>

*Table continues...*

Item	Function
<p style="text-align: center;"><b>More...</b></p> 	<p>Press the <b>More...</b> context-sensitive soft key to select a new menu list of context-sensitive soft keys (two menu lists are available).</p> <ul style="list-style-type: none"> <li>If you press the <b>More...</b> context-sensitive soft key once from the first menu list, you access the following context-sensitive soft keys: [NewCall] [Prefs] [blank] [More....]</li> <li>If you press the <b>More...</b> context-sensitive soft key from the first menu list three times, you return to the first menu list with the following context-sensitive soft keys. [Conf] [Trnsfer] [Audio] [More...]</li> </ul>
<p><i>When you press the <b>More...</b> context-sensitive soft key for the first time, the following context-sensitive soft keys appear on the menu list.</i></p>	
<p style="text-align: center;"><b>NewCall</b></p> 	<p>Press the <b>NewCall</b> context-sensitive soft key to obtain a dial tone to place another call during an active call or to make a conference call.</p> <p>The <b>NewCall</b> context-sensitive soft key behaves like the <b>Conf</b> context-sensitive soft key.</p>
<p style="text-align: center;"><b>Prefs</b></p> 	<p>Press the <b>Prefs</b> context-sensitive soft key to display the Preferences menu.</p> <p>The menu items include the following:</p> <ol style="list-style-type: none"> <li>Display—use to adjust the display settings of the LCD screen.</li> <li>Audio—use to adjust tones and volume settings and to configure a USB headset.</li> <li>Feature Options—use to configure the following: <ul style="list-style-type: none"> <li>Feature keys</li> <li>Call Ignore Action</li> <li>Call Subject</li> <li>Call Fwd Notification</li> <li>Missed Call Notification</li> </ul> </li> <li>Language—use to change the interface language.</li> <li>Misc Options—use to access the following options: <ul style="list-style-type: none"> <li>Alpha Dialing</li> <li>Search Method</li> <li>Incoming Privacy</li> <li>Outgoing Privacy</li> <li># Ends Dialing</li> </ul> </li> </ol>

*Table continues...*

Item	Function
	<ul style="list-style-type: none"> <li>• Hold Mode: Private</li> <li>• Time</li> </ul> <p>6. Network—use to access the following:</p> <ul style="list-style-type: none"> <li>• Server Settings</li> <li>• Device Settings</li> <li>• Diagnostics</li> <li>• Disable screensaver</li> <li>• Licensing</li> <li>• Lock</li> </ul> <p>7. USB Locks—use to lock or unlock the following USB devices:</p> <ul style="list-style-type: none"> <li>• USB Mouse</li> <li>• USB Keyboard</li> <li>• USB Headset</li> <li>• USB flash drive</li> </ul> <p>8. User Settings—use to modify the following:</p> <ul style="list-style-type: none"> <li>• Call Settings</li> <li>• IM Settings</li> <li>• Voice Mail Settings</li> <li>• Change Location</li> </ul>
(blank)	No soft key label.
<p><b>More...</b></p> 	Press the <b>More...</b> context-sensitive soft key to return to the first menu list of context-sensitive soft keys.
<p><b>Unlock</b></p> 	<p> <b>Note:</b></p> <p>The <b>Unlock</b> context-sensitive soft key appears if you answer a call when the IP Deskphone is locked with a password protected screensaver.</p>

**Related links**

[Context-sensitive soft keys](#) on page 22

## Visual indicators

The IP Deskphone uses visual indicators or cues to indicate incoming calls and messages. The display icons on the IP Deskphone also indicate the current call state, the status of Inbox calls, and Instant Messages (IMs), and the Presence state of contacts designated as Friend.

### Related links

[Introduction to the Avaya 1165E IP Deskphone](#) on page 15






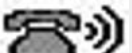

[Display screen icons](#) on page 31





[Visual Alerter/Message Waiting Indicators](#) on page 33




## Display screen icons







The following tables list the screen display icons for:

- **Call state** — Icons to indicate the call state of your phone.
- **Instant Messaging** — Icons displayed when you view your instant message log. The icon appears beside each IM to indicate the status.
- **Inbox** — Icons to indicate the status of each incoming calls in your Inbox.
- **Busy Lamp Field** — Icons to indicate user status using the Busy Lamp Field feature.
- **Presence** — Icons to indicate the presence state of your Address Book entries you designate as Friend.

Call state	Icon
On hook	
On the phone	
On hold	
Call Forward	
Do Not Disturb	
Outgoing call, Incoming call (ringing)	
Missed call	

Instant messaging	Icon
New, unread	
Read	
Replied to	
Sent/forwarded	

Inbox	Icon
Incoming Call Answered	
Incoming Call, Missed, New	
Incoming Call, Missed, Reviewed	

Busy Lamp Field	Icon
Terminated	
Connected Inactive (only available if audio presence is activated)	
Unavailable Busy, or Offline	
Active Available (only available if audio presence is activated)	
On the Phone (only available if audio presence is activated)	
Unknown	








Presence	Icon
Available	
Away or Out of office	

Table continues...



Presence	Icon
Busy	
Do not disturb	
Offline	
On the Phone	
Unknown	

### Related links

[Visual indicators](#) on page 31

## Visual Alerter/Message Waiting Indicators

The red LED light at the top right of the IP Deskphone lights to indicate incoming calls or when a caller leaves you voice mail. The blue LED light at the top left of the IP Deskphone lights to indicate when you receive a new Instant Message.

The following table lists the visual indicator and the LED status.

**Table 5: Visual Alerter/Message Waiting Indicator**

LED	Visual indicator	LED status
Red LED	Voice mail left by caller	Steady red light until message is reviewed
	Incoming call (phone ringing)	Fast blinking red light
Blue LED	New Instant Message received	Steady blue light until message is reviewed
	New Instant Message received when other unread Instant Messages are in the Inbox	Single flash and returns to steady blue light.
	Instant Message pop-up appears and a new Instant Message received	Steady blue light until the Instant Message is reviewed or you press the <b>Exit</b> context-sensitive soft key.

### Related links

[Visual indicators](#) on page 31

## Using a USB Mouse

The Avaya 1165E IP Deskphone is equipped with a USB port in which you can connect a USB mouse. You can use the USB mouse to activate context-sensitive soft key items and menu items.

Use your mouse to click a context-sensitive soft key label of the LCD screen to activate that item. When a menu is open, double-click on a menu item to activate it or click on the item to highlight it. For example, you can click the View context-sensitive soft key label to open that menu. Double-click the word Inbox in the menu list; then double-click a name in the Inbox list to initiate a call, or click the item to highlight the name.

To access the Network menu, right-click anywhere on the display.

**\* Note:**

USB mouse support is available for the Avaya 1165E IP Deskphone but does not extend to added Expansion Modules.

### Related links

[Introduction to the Avaya 1165E IP Deskphone](#) on page 15

---

## Available IP Deskphone call features

The IP Deskphone is designed to be supported by various call servers. The specific call server in which the IP Deskphone is connected to determines whether certain features are available to your IP Deskphone. Call features must be assigned to your IP Deskphone and must be supported by call server software.

**\* Note:**

- Not all feature are available. To determine which features are available or to activate features, contact your system administrator or service provider.
- Not all service providers support the entry of a SIP address to initiate a call, for example, jim@companya.com. Some service providers require that you enter a Directory Number (DN) to initiate a call, for example, 555-5555. Contact your system administrator to determine whether your call server supports SIP address dialing.

### Related links

[Introduction to the Avaya 1165E IP Deskphone](#) on page 15

---

## Security features

Before you can use your IP Deskphone, an ID and password must be assigned to your IP Deskphone. This security measure ensures that, after you log off, calls cannot be made from your IP

Deskphone and features such as Address Book, Instant Message logs, and Call Outbox are inaccessible. Your ID and password also prevent unauthorized access to your user profile.

### Related links

[Introduction to the Avaya 1165E IP Deskphone](#) on page 15

[Secure connection](#) on page 35

---

## Secure connection

Call security is identified by the presence of a security icon (padlock) that is displayed on the IP Deskphone screen.

After the IP Deskphone is registered with the SIP Proxy, the security icon is displayed when:

- the IP Deskphone is idle
- you are on an active call

### Related links

[Security features](#) on page 34

---

## Navigation keys

This section provides information about the keys you can use to navigate within the menus of your Avaya IP Deskphone.

### **Note:**

Menu items are sorted by number.

You can select menu items in one of the following ways:

- Press the corresponding number on the dialpad and then press the **Select** soft key.
- Use the navigation key to scroll through the menu to highlight the item you want to select and then press the **Select** soft key.

### **Press the Left or Right arrows on the Navigation Key Cluster to:**

- Scroll long lines of text when you view caller ID.

### **Note:**

The IP Deskphone automatically scrolls long lines of text from right to left for entries such as in your Address Book or your Call Inbox. When your Search Method is set to Index Search, you can increase the speed of the scrolling by repeatedly pressing the right navigation key or decrease the scrolling speed by repeatedly pressing the left navigation key. For more information, see “Searching for a contact in the Address Book”.

- Change the slide adjustment from left to right when you adjust such things as contrast or volume.

**Press the right side of the Navigation Key Cluster to:**

- Create a space when you enter and edit text.
- View the details of the selected call log entry in the Inbox and the Outbox.

**Press the left side of the Navigation Key Cluster to:**

- Move cursor to the left when you enter and edit text.
- Leave the detail view of the Inbox or Outbox and return to the main Inbox or Outbox. Operates like the **Back** soft key.

**Press the up or down arrows on the Navigation Key Cluster to:**

- Highlight items in a list, such as Address Book entries or items in your Call Inbox.
- Scroll lists and message contents when you view Instant Messages.
- Move the cursor from line to line when entering and editing text or data.

 **Note:**

To scroll through a list of items, you can press and hold the up or down key.

**Press the up arrow on the Navigation Key Cluster to:**

- Erase a character (backspace) when entering characters
- Erase a character (backspace) when editing characters

**Press the down arrow on the Navigation Key Cluster to:**

- Toggle the last alpha character between upper and lower case when entering characters (during alpha entry mode when the **abc** soft keys are displayed)
- Toggle the last alpha character between upper and lower case when editing characters (during alpha entry mode when the **abc** soft keys are displayed)

**Related links**

[Introduction to the Avaya 1165E IP Deskphone](#) on page 15

# Chapter 4: Installing the 1165E IP Deskphone

This chapter describes how to install and connect your 1165E IP Deskphone.

After you familiarize yourself with the Avaya 1165E IP Deskphone features, you can start to use the IP Deskphone.

## Related links

[Before you begin](#) on page 37

[Connecting the components](#) on page 37

[Entering text](#) on page 45

---

## Before you begin

### Caution:

Do not plug your IP Deskphone into a regular telephone jack. This can result in severe damage to the IP Deskphone. Consult your system administrator to ensure that you plug your telephone into a 10/100/1000 BaseT Ethernet jack.

### Caution:

Your IP Deskphone is designed for use in an indoor environment only.

### Caution:

Do not plug your Avaya 1165E IP Deskphone into an Integrated Service Digital Network (ISDN) connection. Severe damage to the Avaya 1165E IP Deskphone can result.

## Related links

[Installing the 1165E IP Deskphone](#) on page 37

---

## Connecting the components

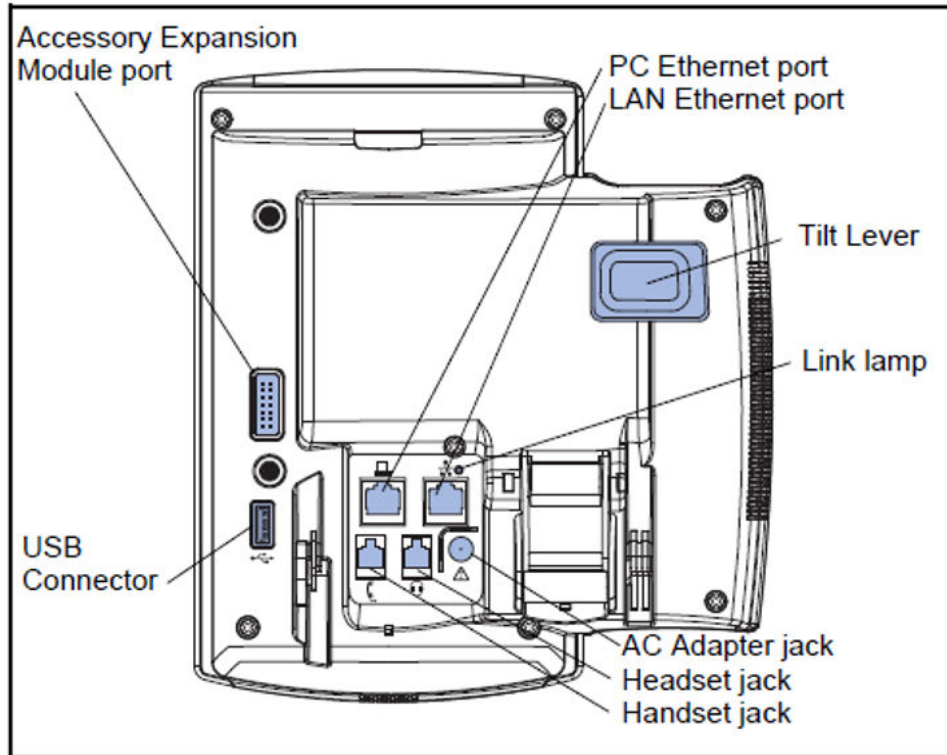
Install your IP Deskphone by completing the following procedures in the order listed:

- Removing the stand cover

## Installing the 1165E IP Deskphone

- Connecting the AC power adapter (optional)
- Connecting the handset
- Connecting the headset (optional)
- Connecting the LAN ethernet cable
- Installing additional cables
- Wall-mounting the IP Deskphone (optional)

The following figure shows the connections on the IP Deskphone.

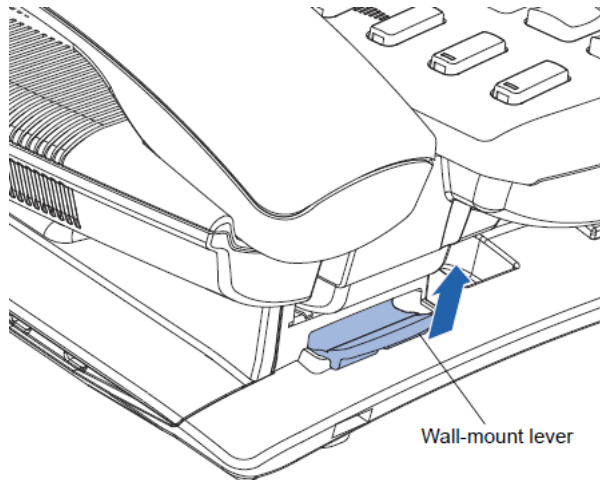


**Figure 5: IP Deskphone connections**

### **Warning:**

Ensure that the protective rubber cap on the Expansion Module port is in place when the port is not in use. Connection of anything other than the proper Expansion Module connector to this port can cause damage to the IP Deskphone.

Your IP Deskphone is shipped with the base locked in position. To avoid damaging your phone, press the wall-mount lever, located under the **Handsfree** key, to release the base and pull it away from the IP Deskphone.



**Figure 6: Wall-mount lever.**

### Related links

- [Installing the 1165E IP Deskphone](#) on page 37
- [Removing the stand cover](#) on page 39
- [Connecting the AC power adapter \(optional\)](#) on page 40
- [Connecting the handset](#) on page 41
- [Connecting the headset \(optional\)](#) on page 41
- [Selecting the headset tuning parameter](#) on page 41
- [Installing additional cables](#) on page 42
- [Wall-mounting the IP Deskphone \(optional\)](#) on page 42

---

## Removing the stand cover

To access the cable routing tracks and attach cables, you must remove the stand cover. Pull upward on the center catch as indicated in the following figure, and remove the stand cover. The cable routing tracks are now accessible.

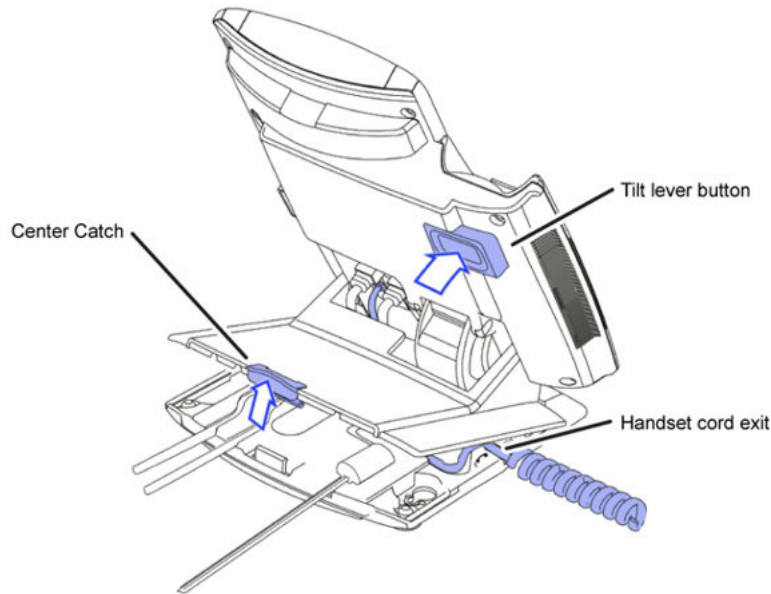


Figure 7: Remove the stand cover

#### Related links

[Connecting the components](#) on page 37

---

## Connecting the AC power adapter (optional)

Your Avaya 1165E IP Deskphone supports AC power or Power over Ethernet (PoE) options, including IEEE 802.3af standard power.

To use local AC power, use only the Avaya-approved Global Power Supply (NTYS17xxE6). You can order the Avaya-approved AC adapter separately.

#### **Warning:**

Use only the approved Avaya Global Power Supply with your 1165E IP Deskphone.

To use PoE, where power is delivered over the CAT5 cable, your connected LAN must support PoE. If you use PoE, you do not require an AC adapter.

#### **Warning:**

If you are connected to a PoE connection do not use the AC power adapter.

To use gigabit Ethernet, you must connect to the LAN through CAT-5e (or later) cables.

To connect the AC adapter to the AC adapter jack in the bottom of the IP Deskphone use the following procedure:

1. Form a small bend in the cable.
2. Thread the adapter cord through the channels in the stand.

#### Related links

[Connecting the components](#) on page 37



---

## Connecting the handset

Use the following procedure to connect the handset to the IP Deskphone.

1. Connect the end of the handset cable with a short straight section to the handset.
2. Connect the end of the handset cable with the long straight section, into the RJ-9 handset jack marked with the handset symbol on the back of the IP Deskphone.

The handset symbol is as follows:



3. Form a small bend in the cable.
4. Thread the handset cord through the channels in the stand so that it exits behind the handset on the right side, using the handset cord exit in the stand base marked with the handset symbol as shown in [Connecting the handset](#) on page 41.

### Related links

[Connecting the components](#) on page 37

---

## Connecting the headset (optional)

Use the following procedure to connect the optional headset to the IP Deskphone.

1. On the back of the IP Deskphone, plug the headset connector into the RJ-9 headset jack marked with the headset symbol.

The headset symbol is as follows:



2. Thread the headset cord, along with the handset cord, through the channels in the stand so that the headset cord exits the channel marked with the headset symbol.

### Related links

[Connecting the components](#) on page 37

---

## Selecting the headset tuning parameter

Follow this procedure after the 1165E IP Deskphone and headset are installed and you are using the IP Deskphone for the first time with the headset.

You can select a headset from the following list of supported headsets.

- Type 1: Monaural and Binaural Headset
  - Monaural Headset: Plantronics Model number: H251N (Part number: 64338-01) with cable Model Number: A10 (Part Number: 66268-02)
  - Binaural Headset: Plantronics Model number: H261N (Part number: 64339-01) with cable Model Number: A10 (Part Number: 66268-02)

- Type 2: Monaural and Binaural Headset
  - Monaural Headset: Plantronics Model number: HW251N (Part number: 75100-06) with cable Model Number: A10 (Part Number: 66268-02)
  - Binaural Headset: Plantronics Model number: HW261N (Part number: 75101-06) with cable Model Number: A10 (Part Number: 66268-02)
- Type 3: Binaural Headset
  - Binaural Headset: GN Netcom Model number: GN 4800 (Part number: 48492-09)

After you select a headset, the corresponding tuning parameters are applied automatically.

Use the following procedure to select a headset.

1. Press **Prefs**.
2. Select **Audio**.
3. Select **Headset Type**.

#### Related links

[Connecting the components](#) on page 37

---

## Installing additional cables

If applicable, you can plug an optional USB device such as a USB mouse or a USB keyboard into your IP Deskphone. Connect the USB cable to the USB port on the back of the IP Deskphone.

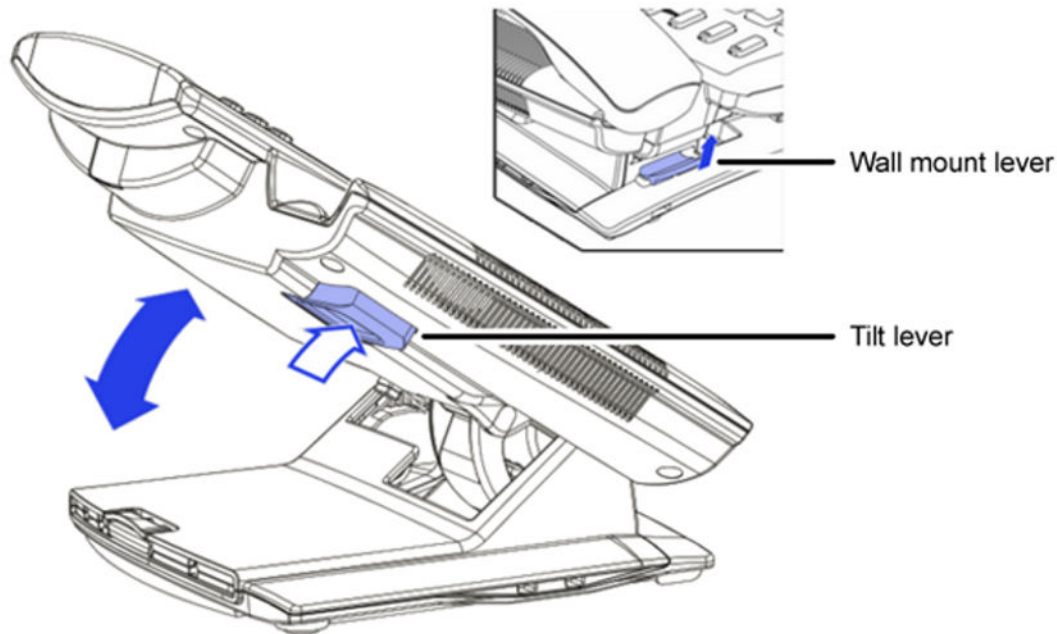
#### Related links

[Connecting the components](#) on page 37

---

## Wall-mounting the IP Deskphone (optional)

You can mount your IP Deskphone on a wall either by: (method A) using the mounting holes on the bottom of the IP Deskphone stand or (method B) using a traditional-style wall-mount box with an RJ-45 connector and 15 centimeter (cm) (6-inch) RJ-45 cord (not provided).

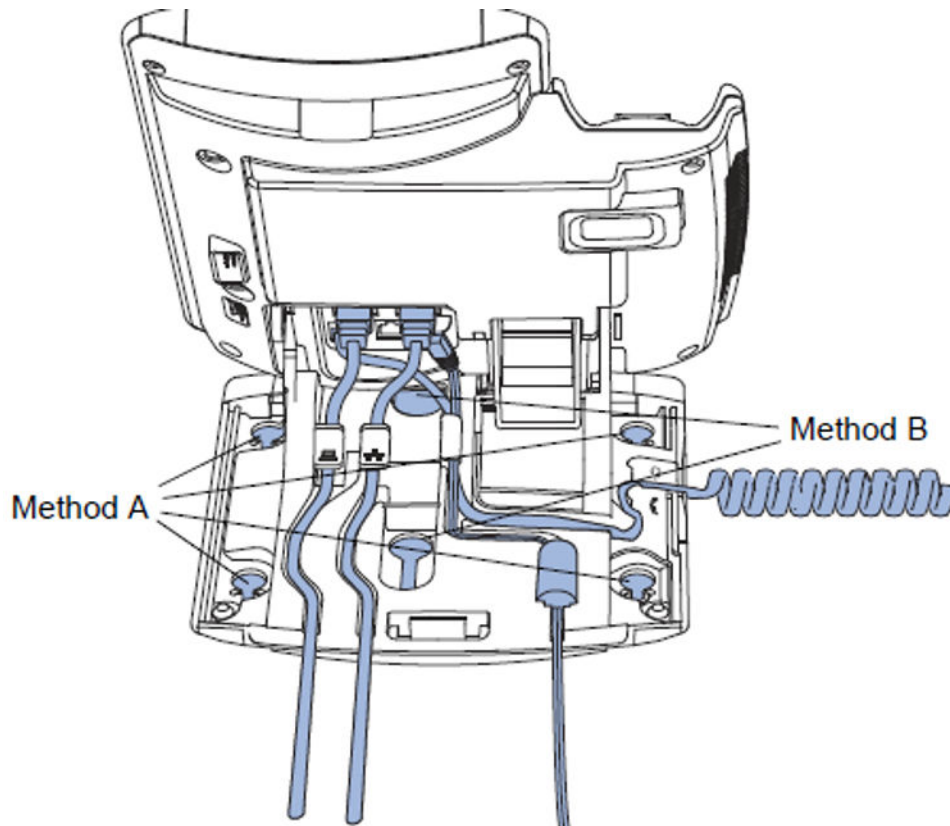


**Figure 8: Rotate the IP Deskphone into the wall mount position**

Complete these steps, as needed, before you wall-mount your IP Deskphone:

**Method A:**

1. Press the wall-mount lever, and pull the IP Deskphone away from the stand.
2. Use the stand cover to mark the wall-mount holes by pressing the bottom of the stand cover firmly against the wall in the location where you wish to install the IP Deskphone. Four small pins on the bottom of the stand cover make marks on the wall.
3. Use the marks as a guideline for installing the wall-mount screws (not provided). Install the screws so that they protrude 3 millimeters (mm) (1/8 inch) from the wall.
4. Install the IP Deskphone stand mounting holes over the screw heads as indicated in the following figure — Method A. You need to remove the IP Deskphone from the wall to adjust the lower screws.
5. When the lower screws are snug, install the IP Deskphone on the mounting screws, and then tighten the top screws.



**Figure 9: Cable routing tracks and mounting holes**

**Method B:**

1. Attach the 15-cm (6-inch) CAT5e cable.
2. Position the stand over the mounting rivets, and slide the IP Deskphone down the wall so that the rivets fit into the slots on the stand, indicated in the preceding figure — Method B.
3. Replace the stand cover. Ensure that all cables are neatly routed and press the stand cover into place until you hear a click.
4. Put the IP Deskphone in the wall-mount position (optional). If you wall-mount your IP Deskphone, put it in the wall-mount position by holding the Tilt Lever and pressing the IP Deskphone towards the base until the IP Deskphone is parallel with the base. Release the Tilt Lever and continue to push the IP Deskphone towards the base until you hear an audible click. Ensure the IP Deskphone is securely locked in position.

**\* Note:**

To add an Expansion Module for Avaya 1100 Series IP Deskphones, see *Expansion Module for Avaya 1100 Series IP Deskphones (SIP Software) User Guide (NN43110-301)*.

**Related links**

[Connecting the components](#) on page 37

---

## Entering text

You can use the following methods to enter and edit text on your IP Deskphone:

- [Entering text using the IP Deskphone dialpad](#) on page 45
- [Entering text using the USB keyboard](#) on page 48

### Related links

[Installing the 1165E IP Deskphone](#) on page 37

[Using the dialpad](#) on page 45

[Entering text using the USB keyboard](#) on page 48

---

## Using the dialpad

You can use combinations of the letters and numbers on the dialpad of your IP Deskphone to, for example, spell names or words in Instant Messages (IMs), enter SIP addresses, create Address Book entries, and to designate feature key labels.

To make a call, you can dial an alphanumeric SIP address (for example, `jdoe2@domain.com`) or you can dial a Directory Number (DN), depending on the local system configuration.

### \* Note:

Some service providers support only the use of a Directory Number (DN) such as 555-5555 to initiate a call to another IP Deskphone. Contact your system administrator or service provider to determine if alphanumeric dialing is supported. Alphanumeric dialing consists of string of text that contain letters and numbers that make up, for example, a SIP address.

### Related links

[Entering text](#) on page 45

[Entering text using the IP Deskphone dialpad](#) on page 45

[Enabling and disabling the # Ends Dialing feature](#) on page 47

[Configuring the dialpad to alphanumeric dialing](#) on page 47

## Entering text using the IP Deskphone dialpad

For applications that offer text input, when you use the dialpad to enter text the system activates the **abc/123** context-sensitive soft key.

You can toggle between numeric and alphabetic input as follows:

- When the soft key label is **abc**, you can enter alphabetic text.
- When the soft key label is **123**, you can enter numbers.

For example, if you want to enter the lower case letter *a*, press the **abc/123** soft key to toggle to alphabetic input. Then press the number **2** key once. If you want to enter the upper case letter *C*, press the number **2** key six times. You can cycle through the letters (and the numeral) by pressing the number button repeatedly.

To create names or words that contain two adjacent letters that appear on the same button, for example, the word **prime**, you can do the following:

1. To enter the first character, press the dialpad key **6**.
2. Pause briefly.
3. To enter the next letter, press the dialpad key **6** twice to cycle to the letter r.

When entering alphanumeric information, the **1** key on the dialpad represents the characters in the following table. To enter a special character, press the dialpad number **1** to cycle through the characters until you reach the one you need. For example, to enter a question mark (?), press the number **1** key eight times.

**Table 6: Alphanumeric characters for dialpad key 1**

Character	Name
@	at
.	period
-	dash
_	underscore
&	ampersand
'	apostrophe
^	carat
?	question mark
!	exclamation point
(	left parentheses
)	right parentheses
,	comma
\	backslash
/	forward slash
:	colon
;	semi-colon
~	tilde
=	equal
+	plus
1	numeral 1

**\* Note:**

No letters are associated with the **0** (zero) key; however, double-pressing it inserts a blank character (a space).

**Related links**

[Using the dialpad](#) on page 45

## Enabling and disabling the # Ends Dialing feature

You can enable the IP Deskphone to use the octothorpe (#) symbol to immediately dial the address or phone number.

### To enable the # Ends Dialing feature:

1. Press the **Prefs** soft key, and then select **Misc Options**. Highlight **# Ends Dialing** and press the **Change** soft key.
2. Press the **On** soft key to turn on **# Ends Dialing**.

**OR**

Press the **Back** soft key to keep existing configurations and return to the **Preferences** menu.

### To disable the # Ends Dialing feature:

1. To turn off **# Ends Dialing**, press the **Prefs** context-sensitive soft key, and then select **Misc Options**. Highlight **# Ends Dialing** and press the **Change** context-sensitive soft key.
2. Press the **Off** context-sensitive soft key to turn off **# Ends Dialing**.

**OR**

Press the **Back** context-sensitive soft key to keep existing configurations and return to the **Preferences** menu.

### Related links

[Using the dialpad](#) on page 45

## Configuring the dialpad to alphanumeric dialing

To eliminate the need to press the **abc/123** soft key when you enter text, you can configure the IP Deskphone dialpad default to alphabetic mode.

### To configure the dialpad to alphabetic mode as the default:

1. Press the **Prefs** soft key, and then select **Misc Options**. Highlight **Alpha Dialing**, and then press the **Change** soft key.
2. Press the **On** soft key to turn on alphanumeric dialing.

**OR**

Press the **Back** soft key to keep existing configurations and return to the **Preferences** menu.

### To disable alphabetic mode and configure numeric mode as the default:

1. Press the **Prefs** soft key, and then select **Misc Options**. Highlight **Alpha Dialing**, and then press the **Change** soft key.
2. Press the **Off** soft key to turn on alphanumeric dialing.

**OR**

Press the **Back** soft key to keep existing configurations and return to the **Preferences** menu.

### Related links

[Using the dialpad](#) on page 45

## Entering text using the USB keyboard

You can connect a USB keyboard to the USB port of your IP Deskphone to enter text and numbers, access some features, and duplicate some functions.

For example, to dial a directory number, you can use the keyboard number pad to enter digits and the asterisk (\*) and octothorpe (#) characters and you can use the alphabetic keys to enter text.

The following table describes the associations between the USB keyboard function keys and the IP Deskphone fixed keys.

**Table 7: Associations between the USB keyboard function keys and the IP Deskphone fixed keys**

USB Keyboard Key	IP Deskphone Fixed Key
Esc	Quit
F1	Services
F2	Expand
F3	Inbox
F4	Outbox
F5	Address Book
F6	Copy
F7	Volume Down
F8	Volume Up
F9	Mute
F10	Hold
F11	Headset
F12	Handsfree
Break	Goodbye (Release)
Backspace	Left arrow of Navigation Cluster
Arrow Left	Left arrow of Navigation Cluster
Arrow Right	Right arrow of Navigation Cluster
Arrow Up	Up arrow of Navigation Cluster
Arrow Down	Down arrow of Navigation Cluster
Enter	Enter

### Related links

[Entering text](#) on page 45



# Chapter 5: Accessing the Avaya 1165E IP Deskphone

You require a log on ID and a password to log on to a server with your Avaya 1165E IP Deskphone.

## Related links

- [Logging on](#) on page 49
- [Timed logoff](#) on page 54
- [Selecting a location](#) on page 55
- [User Profile](#) on page 55
- [Confirmation logon screen](#) on page 56
- [Logging off from the IP Deskphone](#) on page 57
- [Making an emergency call](#) on page 57

---

## Logging on

Whenever you log on to your Avaya IP Deskphone, you must do the following:

- confirm your logon ID
- enter your password
- select the duration of this session

The first time you use your IP Deskphone, you need to complete some of the procedures in the following topics:

- Automatic login
- Configuring the domain
- Selecting a language
- Logging on to your IP Deskphone
- Configuring the duration of the login
- Selecting a location
- User Profile
- Overwriting your personal Address Book

**\* Note:**

The system automatically logs you back on after a power outage or software upgrade. The system administrator configures this feature on a network-wide basis.

**Related links**

[Accessing the Avaya 1165E IP Deskphone](#) on page 49

[Automatic login](#) on page 50

[Configuring the domain](#) on page 50

[Password protection for domains](#) on page 51

[Selecting a language](#) on page 51

[Logging on to your Avaya IP Deskphone](#) on page 52

[Configuring the duration of the login](#) on page 53

[Logging on multiple user accounts](#) on page 53

---

## Automatic login

Before you first receive your Avaya 1165E IP Deskphone, your system administrator can configure your IP Deskphone with your user logon and password. If this is the case, after you plug in the IP Deskphone you can use it without further configuration.

**\* Note:**

If the IP Deskphone is configured with automatic logon, you can not use the log off function, and you need a password to access some features and functions. Contact your system administrator or service provider for further information.

**Related links**

[Logging on](#) on page 49

---

## Configuring the domain

Before the log on process, if you need to change the domain or confirm that the domain you log on to is correct, press the **Domain** soft key from the logon prompt. The current domain appears on the IP Deskphone LCD screen. You can edit the domain that is listed or press the **Domain** soft key to access a list of available domains to which you can choose to connect.

**\* Note:**

- You must enter the admin password to edit domains.
- Check with your system administrator before editing or changing domains.

**To change the domain:**

1. Press the **Domain** soft key to change the current domain.

**\* Note:**

You must enter an admin password before you can edit the domain in which the IP Deskphone connects.

2. Press the Up/Down navigation key to highlight the new domain you want to use.
3. Press the **Select** soft key to change the domain to the highlighted domain from the list. The IP Deskphone returns to the **Current Domain** page, and the new domain appears.

OR

Press the **Back** soft key to keep existing configurations and return to the previous menu.

#### Related links

[Logging on](#) on page 49

## Password protection for domains

This feature supports admin password protection for editing of the domain and is not required for switching domains. If you log on using the administrator password, you can use the editing domain option for both the Current Domain state and Domain List state.

After you press **back** on the edit page or on the password prompt, the idle display appears. You must enter the admin password to reenter the editing domain.

#### Related links

[Logging on](#) on page 49

## Selecting a language

Your IP Deskphone has the capacity to operate using other languages, such as French. The system administrator can provision the IP Deskphone with up to five languages. If the IP Deskphone is provisioned with other languages, you can choose an available language during the login process by pressing the **Lang** soft key on the **User Login** page.

#### To change the language:

1. Press the **Change** soft key to change the current language.

OR

Press the **Back** soft key to keep existing language and return to the **User Login** screen.

2. Press the **Up/Down navigation key** to highlight the new language you want to use.
3. Press the **Select** soft key to change the language to the highlighted language from the list. The IP Deskphone returns to the **User Login** screen and uses the selected language.

OR

Press the **Back** soft key to keep the existing language and return to the **User Login** screen.

#### Related links

[Logging on](#) on page 49

---

## Logging on to your Avaya IP Deskphone

You need to log on to your Avaya IP Deskphone when you first install and restart your IP Deskphone and anytime you log off or reboot.

**\* Note:**

- When you log on to the IP Deskphone for the first time, the system prompts you for a location.
- The IP Deskphone retains the previous user logon ID, which appears after the ID prompt whenever the IP Deskphone reboots.

If Authentication is enabled by your system administration, you can enter your authentication ID independent of your user ID. The authentication ID is used when the server challenges the IP Deskphone.

### To log on to the IP Deskphone:

1. Press the **abc/123** soft key to toggle between alphabetic or numeric input.
2. Use the dialpad to enter your user ID login at the prompt.

**\* Note:**

Use the left navigation key to backspace and remove a previous user ID.

3. Press the **Login** soft key. If Authentication is enabled by your system administration, you are presented with the Authentication ID screen. The authentication ID is autofilled with your user ID.

If Authentication is not enabled, a new screen appears and prompts you for your password:

- Press the **abc/123** soft key to toggle between alphanumeric or numeric input.
  - Use the dialpad to enter your authentication ID login at the prompt.
  - Press the **Login** soft key.
4. Enter your password by using the dialpad.

**\* Note:**

- When you enter your password, the last character entered appears. However, all previous characters are hidden.
- When you enter your password and you use the navigation key to backspace, you erase all the characters and must completely re-enter your password again.

5. Press the **Next** context-sensitive soft key.

**\* Note:**

You can cancel the login process by pressing one of the following keys:

- Cancel
- Goodbye

- Quit

#### Related links

[Logging on](#) on page 49

---

## Configuring the duration of the login

After you enter your logon ID and password the **Duration** screen appears. You can enter the maximum length of time of the session. If you choose to use the default duration Permanent, you remain logged on to the phone until you log off.

#### To configure the login duration:

1. Press the **Next** soft key to configure the logon duration to **Permanent**. A login confirmation screen appears.

OR

Press the **Timed** soft key to open a screen to configure a maximum time to remain logged in.

#### **Note:**

If you press the **Timed** soft key, you must then configure the duration of the login.

2. Press the **Period** soft key to toggle the logon duration entries between hours or days.
3. Use the dialpad to enter the number of hours or days you want to remain logged on and press the **Next** context-sensitive soft key.

OR

Press the **Back** soft key to return to the permanent logon screen.

OR

Press the **Cancel** soft key to return to the first logon screen.

#### Related links

[Logging on](#) on page 49

---

## Logging on multiple user accounts

The Avaya 1165E IP Deskphone has a multiuser feature that allows multiple SIP user accounts to be active on the IP Deskphone at the same time. For more information about logging on multiple users, see [Multiuser](#) on page 169.

#### Related links

[Logging on](#) on page 49

## Timed logoff

When you determine a logon time other than permanent, the IP Deskphone reminds you of your expiry time.

### Related links

[Accessing the Avaya 1165E IP Deskphone](#) on page 49

[Timed logoff while IP Deskphone is idle](#) on page 54

[Timed logoff while on a call](#) on page 54

---

## Timed logoff while IP Deskphone is idle

When the login time expires and the IP Deskphone is idle (not on a call), you can do one of the following at the prompt:

- Press the **Yes** context-sensitive soft key to log off immediately.
- Press the **No** context-sensitive soft key to switch to Permanent logon.
- Press the **Quit** or **Release/Goodbye** key to logout immediately.

If you do not respond, the prompt times out in 45 seconds and the IP Deskphone logs off.

If you answer a call during the logout prompt, the logon switches to permanent login.

### Related links

[Timed logoff](#) on page 54

---

## Timed logoff while on a call

When the login time expires while you are on a call, you can do one of the following at the prompt:

- Press the **Yes** context-sensitive soft key to log off immediately.
- Press the **No** context-sensitive soft key to switch to Permanent logon.
- Press the **Quit** key to dismiss the log out prompt and switch to permanent login.
- Press the **Release/Goodbye** key to dismiss the logout prompt and switch to permanent login.

### **Note:**

If you press the **Release/Goodbye** key to dismiss the logout prompt, you also terminate the call.

If you do not respond, the prompt times out in 45 seconds and the phone switches to permanent login.

### Related links

[Timed logoff](#) on page 54

---

---

## Selecting a location

When you first login to the IP Deskphone, the system prompts you for a location. The location you select is saved in your User Profile.

Depending on your service provider, the Enhanced Emergency Service uses the location you select or the Directory Number (DN) on the call server, when handling emergency calls. The configuration of the call server determines how emergency service calls are handled by your IP Deskphone.

**\* Note:**

- During an emergency call, you cannot log out from the IP Deskphone or release or disconnect the call. The IP Deskphone remains connected to the emergency service until the emergency service operator disconnects it.
- If the login time expires during an emergency call, a prompt does not appear and the IP Deskphone automatically switches to permanent login.
- When you configure your user profile for the first time, you must confirm that the selected location is correct. You can view your location by accessing the IP Deskphone information screen. For more information, see [Viewing the IP Deskphone information](#) on page 144.

### Related links

[Accessing the Avaya 1165E IP Deskphone](#) on page 49

---

## User Profile

Your User Profile contains your specific settings and data. You are prompted to create a User Profile the first time you log on to your IP Deskphone. If you delete your User Profile, the IP Deskphone reboots, and you must log on and create a new User Profile. When you log on to your IP Deskphone, your specific settings and data are automatically available for you.

The information stored in your user profile includes:

- Independent volume adjustments for handset, headset, and handsfree
- Alerting Volume adjustment
- Idle Screen display text
- Voice Mail settings (number and mailbox ID)
- User location (from a server-provided list)
- Time, Date, and Zone format settings
- Call Subjects
- Instant Messaging settings and Instant Message Inbox/Outbox
- Default dialing (alpha/numeric)
- Call Ignore action (local/network)
- Search method (Name, First character, Index)

- User Presence selection
- Dialing pattern default (alpha/numeric)
- Address Book entries
- Call Inbox and Call Outbox entries
- Programmable keys configuration
- # Ends dialing configuration

#### Related links

[Accessing the Avaya 1165E IP Deskphone](#) on page 49

[Overwriting your personal Address Book](#) on page 56

---

## Overwriting your personal Address Book

When an address book exists on a call server, such as an address book for a specific company, you can update your personal Address Book with an address book from the call server. The system administrator configures the system to enable this feature. If a new address book is available on the call server, the IP Deskphone prompts you to download the latest address book.

#### Related links

[User Profile](#) on page 55

---

## Confirmation logon screen

When you complete the logon process, a logon confirmation screen appears. Press **OK** to complete the logon process.

If the login is unsuccessful, a login error message

```
Failed to login user
```

is displayed.

Press the **OK** soft key to return to the first logon screen.

The most common cause for logon failure is the incorrect entry of the password.

#### Related links

[Accessing the Avaya 1165E IP Deskphone](#) on page 49



---

## Logging off from the IP Deskphone

### To log off from the IP Deskphone:

1. Press the **Services** fixed key, and then select **Logout** from the menu.
2. Press the **abc/123** soft key to toggle between alphabetic or numeric input.
3. Use the dialpad to enter your password at the prompt.
4. Choose one of the following:
  - Press the **Logout** soft key to complete the logout process. The IP Deskphone returns to the **User Login** screen.
  - Press the **Back** soft key to remain logged on and return to the Services menu.

### Related links

[Accessing the Avaya 1165E IP Deskphone](#) on page 49

[Logging off multiple user accounts](#) on page 57

---

## Logging off multiple user accounts

The IP Deskphone has a multiuser feature that allows multiple SIP user accounts to be active on the IP Deskphone at the same time. By logging off of the primary account, all other accounts log off automatically. By logging off of a secondary account, you remove the selected secondary account from the autologin list.

### Related links

[Logging off from the IP Deskphone](#) on page 57

---

## Making an emergency call

You can use the IP Deskphone to make an emergency call to the Public Safety Answering Point (PSAP) from any accessible screen without logging on.

When you pick up the handset, press the Handsfree key or Headset key without logging on, a message “Emergency calls only” appears, and the IP Deskphone can only be used to make an emergency call. All soft keys and feature keys are blank and unusable except for the second soft key which allows you to switch between numeric and alphabetic characters. If you hang up before the connection is established, the IP Deskphone returns to the initial state. After the connection is established, the call can be disconnected only by an operator. If you hang up after the connection has been made, the IP Deskphone switches to loudspeaker. If the loudspeaker is already on, and you press the hang up button, nothing happens. The call is not disconnected.

When you make an emergency call, the location of the IP Deskphone is forwarded to the PSAP.

**\* Note:**

When the IP Deskphone is waiting for the user to log on or it is blocked by a screen saver, you can still make an emergency call. If you pick up the handset, a message "Emergency calls only" appears and the IP Deskphone can be used for making only emergency calls.

**To make an emergency call:**

1. Choose one of the following:
  - Pick up the handset.
  - Press the handsfree button.
  - Press the headset button.

**\* Note:**

Hang up or switch off the handset to return to normal state.

2. Dial the emergency number that is provided by your dialing plan.
3. Press the **Send** soft key.

**\* Note:**

If you try to dial the number that does not match the dialing plan, a message appears to inform you that the number is incorrect.

**Related links**

[Accessing the Avaya 1165E IP Deskphone](#) on page 49

[Location information](#) on page 58

---

## Location information

When you make an emergency call, the IP Deskphone provides the PSAP with the location information of the IP Deskphone. The IP Deskphone receives the location information when the IP Deskphone is first plugged in to the network and then stores it.

To view your location, press the **Services** hard key, choose **Phone Information**, and then press the **E911** soft key.

You can obtain location information only if it has been configured on your system.

**Related links**

[Making an emergency call](#) on page 57

# Chapter 6: Configuring the Avaya 1165E IP Deskphone

You can adjust a few settings of the Avaya 1165E IP Deskphone to conform to the environment where you want to use the phone. These settings are saved to your User Profile. This chapter describes some of the settings that you can customize on your IP Deskphone.

## Related links

[Adjusting the display screen contrast](#) on page 59

[Creating the idle screen text display](#) on page 60

[Configuring Menu Auto back-out](#) on page 61

[Selecting a ring pattern](#) on page 62

[Adjusting the volume](#) on page 62

[Selecting a language](#) on page 65

[Selecting the date and time format](#) on page 65

[USB headset](#) on page 67

---

## Adjusting the display screen contrast

### Note:

Adjusting the display screen contrast of the IP Deskphone also adjusts the Expansion Module contrast, if you have an Expansion Module connected to your IP Deskphone.

### To adjust the display screen contrast:

1. Press the **Prefs** soft key, select **Display > Display Settings** and then select **Contrast**.
2. Press the **Left/Right** navigation key to increase or decrease the display contrast level.
3. Choose one of the following:
  - Press the **Apply** soft key to save the changes and return to the **Display** menu.
  - Press the **Cancel** soft key to keep the existing configurations and return to the **Display** menu.

## Related links

[Configuring the Avaya 1165E IP Deskphone](#) on page 59

[Configuring the backlight](#) on page 60

## Configuring the backlight

Configuring the length of time the LCD screen remains backlit on the IP Deskphone also adjusts the Expansion Module backlight time if you have an Expansion Module connected to your IP Deskphone.

### To configure the amount of time the LCD screen remains backlit:

1. Press the **Prefs** soft key, select **Display > Display Settings** and then select **Backlight** from the menu.
2. Press the **Left/Right** navigation key to increase or decrease the length of time you want the idle screen to remain backlit.
3. Press the **Apply** soft key to configure the length of time for the IP Deskphone to remain backlit and return to the **Display** menu.

OR

Press the **Cancel** soft key to keep the existing configurations and return to the **Display** menu.

### Related links

[Adjusting the display screen contrast](#) on page 59

---

## Creating the idle screen text display

You can create a text to display on the screen, while the IP Deskphone is idle.

### To create the idle screen display text:

1. Press the **Prefs** soft key, select **Display**, and select **Idle Screen Text Display**.
2. Press the **abc/123** soft key to toggle between alphabetic or numeric input.
3. Use the dialpad to enter the display text you want to appear on the idle screen display of the IP Deskphone.
4. Press the **Save** soft key to save the idle screen text display.

OR

Press the **Back** soft key to keep the existing screen display text and return to the **Display** menu.

### Related links

[Configuring the Avaya 1165E IP Deskphone](#) on page 59

---

## Configuring Menu Auto back-out

You can use the Menu Auto back-out feature to configure the time interval required for the IP Deskphone to go back to the idle screen when the IP Deskphone is left inactive.

### To configure Menu Auto back-out:

1. Press the **Prefs** soft key, choose **Display**, and then **Menu Auto** back-out.
2. Press the **Select** soft key.

OR

Press the **Back** soft key to return to the previous menu.

3. Press the **Up/Down** navigation key to scroll through the screen and choose the required time interval.

Choose one of the following values:

- Never
- 10 min
- 5 min
- 2 min
- 1 min
- 30 sec
- 15 sec

 **Note:**

The **Never** option turns off Menu Auto back-out.

4. Press the **Select** soft key to configure the Auto back-out time to the selected (highlighted) value and return to the Display menu.

OR

Press the **Back** soft key to dismiss the Auto back-out time menu and return to the Display menu.

 **Note:**

When you enter the Auto back-out menu, the current configuration for the Menu Auto back-out time is pre-selected (highlighted) on the list.

When you press the **Select** soft key, the time interval is flagged to commit to the configured preferences (done after the idle screen is displayed), and is used for menu auto back-outs from that point forward.

### Related links

[Configuring the Avaya 1165E IP Deskphone](#) on page 59

## Selecting a ring pattern

You can use the ring pattern feature to select the ring pattern for an incoming call.

### To select the ring pattern for an incoming call:

1. Press the **Prefs** soft key, select **Audio**, select **Tones**, and then select **Ring Pattern**.
2. Press the **Up/Down** navigation key to scroll through and highlight the different ring patterns displayed on the LCD screen.
3. Press the **Select** soft key to configure the ring pattern and return to the **Tones** menu.

OR

Press the **Test** soft key to briefly play the selected ring pattern.

OR

Press the **Back** soft key to keep the existing configurations and return to the previous menu.

### Related links

[Configuring the Avaya 1165E IP Deskphone](#) on page 59

---

## Adjusting the volume

You can adjust the volume of the IP Deskphone for the following:

- Ring Volume
- Handset Volume
- Headset Volume
- Handsfree Volume
- Paging Ring Volume

A sliding scale appears on the LCD screen display when you adjust the volume.

### Related links

[Configuring the Avaya 1165E IP Deskphone](#) on page 59

[Adjusting the ring volume](#) on page 62

[Adjusting the volume of the Handset, Headset, and Handsfree mode](#) on page 63

[Adjusting the paging ring volume](#) on page 64

---

## Adjusting the ring volume

You can adjust the ring volume for an incoming call.

### To adjust the ring volume for an incoming call:

1. Press the **Prefs** soft key, select **Audio**, select **Tones**, and then select **Alerting Volume**.

2. Press the **Left/Right** navigation keys.  
OR  
Press the **Up/Down** navigation keys.  
OR  
Press the **Volume** fixed keys.
3. Press the **Set** soft key to configure the selected volume and return to the **Tones** menu.  
OR  
Press the **Back** soft key to keep the existing configurations and return to the **Tones** menu.

#### Related links

[Adjusting the volume](#) on page 62

---

## Adjusting the volume of the Handset, Headset, and Handsfree mode

You can adjust the volume for the handset, headset, and the handsfree speaker of the IP Deskphone.

#### To adjust the Handset volume:

1. Press the **Prefs** soft key, select **Audio**, select **Voice**, and then select **Handset**.
2. Press the **Left/Right** navigation keys.  
OR  
Press the **Up/Down** navigation keys.  
OR  
Press the **Volume** fixed keys.

 **Note:**

- To adjust the volume during a call, use only the **Volume +** and **Volume -** fixed keys.
3. Press the **Set** soft key to configure the selected volume and return to the **Voice** menu.  
**OR**  
Press the **Back** soft key to keep existing configurations and return to the **Voice** menu.

You can adjust the headset volume on the IP Deskphone.

#### To adjust the headset volume:

1. Press the **Prefs** soft key, select **Audio**, select **Voice**, and then select **Headset**.
2. Press the **Left/Right** navigation keys.  
OR  
Press the **Up/Down** navigation keys.

OR

Press the **Volume** fixed keys.

**\* Note:**

To adjust the volume during a call, use only the **Volume +** and **Volume -** fixed keys.

3. Press the **Set** soft key to set the selected volume and return to the **Voice** menu.

OR

Press the **Back** soft key to keep the existing configurations and return to the **Voice** menu.

You can adjust the handsfree mode volume on the IP Deskphone.

### To adjust the handsfree mode volume:

1. Press the **Prefs** context-sensitive soft key, select **Audio**, select **Voice**, and then select **Handsfree**.
2. Press the **Left/Right** navigation keys.

OR

Press the **Up/Down** navigation keys.

OR

Press the **Volume** fixed keys.

**\* Note:**

To adjust the volume during a call, use only the **Volume +** and **Volume -** fixed keys.

3. Press the **Set** soft key to set the selected volume and return to the **Voice** menu.

OR

Press the **Back** soft key to keep the existing configurations and return to the **Voice** menu.

### Related links

[Adjusting the volume](#) on page 62

---

## Adjusting the paging ring volume

You can adjust the ring volume for an incoming paging call.

### To adjust the ring volume for an incoming paging call:

1. Press the **Prefs** soft key, select **Audio**, select **Tones**, and then select **Paging Volume**.

The Paging tone is played at the current volume.

2. Press the **Left/Right** navigation keys.

OR

Press the **Up/Down** navigation keys.

OR



- Press the **Volume** fixed keys.
3. Press the **Set** soft key to configure the selected volume and return to the **Tones** menu.

**OR**

Press the **Back** soft key to keep the existing configurations and return to the **Tones** menu.

#### Related links

[Adjusting the volume](#) on page 62

## Selecting a language

The display is available in multiple languages. A maximum of five languages are accessible through the IP Deskphone. The system administrator determines which languages are available for your IP Deskphone.

#### To select a language:

1. Press the **Prefs** soft key, and then select **Language**.  
The current language displays.
2. Press the **Change** soft key to change the language.
3. Press the **Up/Down** navigation key to scroll and highlight the desired language (for example, German [Deutsche]).
4. Press the **Select** soft key to save the desired language and return to the previous screen.

**OR**

Press the **Back** soft key to keep the existing configurations and return to the **Preferences** menu.

#### Related links

[Configuring the Avaya 1165E IP Deskphone](#) on page 59

## Selecting the date and time format

Several date and time formats are available. Formats are based on the 12-hour and 24-hour clocks.

#### To select a date format:

1. Press the **Prefs** soft key, select **Misc Options**, and then select **Time**.
2. Press the **Change** soft key.
3. Press the **Up/Down** navigation key to highlight **Date Format** in the menu.
4. Press the **Change** soft key to change the **Date Format**.
5. Press the **Up/Down** navigation key to scroll and highlight either a month/day (MM/DD) or a day/month (DD/MM) format.

6. Press the **Select** soft key to save the format and return to the **Time Format** menu.

**OR**

Press the **Back** soft key to keep the existing configurations and return to the **Time Format** menu.

You can select a time zone for your IP Deskphone.

**To select a time zone:**

1. Press the **Prefs** soft key, select **Misc Options**, and then select **Time**.
2. Press the **Change** soft key.
3. Press the **Up/Down** navigation key to highlight **Timezone** in the menu.
4. Press the **Change** soft key to change the Date Format.
5. Press the **Up/Down** navigation key to scroll through and highlight the time zones.

**\* Note:**

Time zones are listed based on GMT format, for example:

- GMT -11:00 Samoa
- GMT -10:00 Hawaii

6. Press the **Select** soft key to save the time zone selection and return to the **Time Format** menu.

**OR**

Press the **Back** soft key to keep the existing configurations and return to the **Time Format** menu.

You can select the time zone format for your IP Deskphone.

**To select a time format:**

1. Press the **Prefs** soft key, select **Misc Options**, and then select **Time**.
2. Press the **Change** soft key.
3. Press the **Up/Down** navigation key to highlight **Time Format** in the menu.
4. Press the **Change** soft key change the date format.
5. Press the **Up/Down** navigation key to scroll and highlight a time format:
  - 12-hour
  - 24-hour
  - French
6. Press the **Select** soft key to save the time format and return to the **Time Format** menu.

**OR**

Press the **Back** soft key to keep the existing configurations and return to the **Time Format** menu.

**Related links**

[Configuring the Avaya 1165E IP Deskphone](#) on page 59

---

## USB headset

You can attach only one USB headset to the Avaya 1165E IP Deskphone. (If you add an additional USB headset, the IP Deskphone ignores it without any message.) When you connect the USB headset to the USB port of the IP Deskphone, the IP Deskphone configures the headset to work with it.

The following table lists the types of USB headsets that work with the 1165E IP Deskphone.

**Table 8: Supported USB headset types**

Headset Type	Frequency
Avaya Enhanced USB Headset Adapter	8 KHz
Avaya Mobile USB Headset Adapter	8 KHz
Plantronic CS50/CS60 Wireless USB Headsets	8-48 KHz Continuous Spectrum
GN Netcom 9300 series wired and wireless USB headsets	16 KHz
Algo Analog Terminal Adapter	8 KHz

**Related links**

[Configuring the Avaya 1165E IP Deskphone](#) on page 59

[Headset menu](#) on page 67

[Presence of USB headset](#) on page 69

[Audio format selection](#) on page 69

[Generic USB headset](#) on page 70

[Avaya USB headset adapter with HID](#) on page 70

[Third-party USB headsets with HID](#) on page 73

[Analog Terminator Adapter for analog \(500/2500-type\) telephone or fax machine](#) on page 75

---

## Headset menu

The USB Audio feature adds the USB headset as an alternative headset in addition to the wired headset. You can add a headset to your preferences by clicking on the **Prefs** soft key, and then choosing **Audio**. The Audio option allows you to select and configure the preferred headset.

On the IP Deskphone, after you select **Prefs > Audio > Headset Selection**, use the **Headset** screen to select the desired headset and corresponding functional parameters.

The following table describes the configuration options on the Headset screen.

Option	Function
Active Headset Device	<p>Select the active headset device; either USB or Wired.</p> <p><b>* Note:</b> The headset can be selected before it is attached (wired or USB).</p> <p>Items below the Active Headset Device field are dimmed, if either USB headset is not selected or if the attached headset is not one of the Human Interface Device (HID) supported headset types.</p>
Wired Headset Type	<p>Select the type of wired headset you require.</p> <ul style="list-style-type: none"> <li>• Headset Type 1 (Generic narrow band)</li> <li>• Headset Type 2 (Wideband)</li> <li>• Headset Type 3 (Wideband)</li> </ul>
Enable HID Commands	<p>Enable the HID Commands checkbox only if <b>USB headset</b> is selected.</p> <p>The checkbox is used to enable the HID commands of supported headsets to allow the IP Deskphone to run in generic mode 1 operation, supporting both USB audio and HID commands. The configuration is ignored for non-supported USB headsets.</p>
MHS Headset Type	<p>Choose an MHS Headset Type only if the Avaya headset adapter is detected.</p> <p>This list contains the different wired headset types that can be attached to the Avaya Enhanced or Mobile Adapters for loss plan adjustment. The command is ignored for other types of USB headsets. This item is dimmed if the attached headset is not one of the Avaya headset types.</p>
MHA Back Light	<p>Enable the MHA Back Light (only if Avaya headset adapter is detected).</p> <p>The checkbox is used to enable or disable the back light equipped in Avaya Enhanced or Mobile headsets. The command is ignored for other types of USB headsets. This item is dimmed if the attached headset is not one of the Avaya headset types.</p>

The changes in the menu take effect immediately if the device is attached. The active voice path switches to the selected headset if you are on an active call. If you press the **Apply** soft key, then the changes are applied, the settings are made permanent by storing the values in persistent storage, and they are applied every time the IP Deskphone starts up. All changes made are ignored and restored if you press the **Back** soft key.

**Related links**

[USB headset](#) on page 67

**Presence of USB headset**

On the **System** menu, choose **Phone Information**, and then select **USB** to verify the presence of the USB headset attached to the IP Deskphone. When you select the **USB** menu, the attached USB headset is displayed along with other USB devices. The name of the USB device directly appears from the USB devices themselves. The product description has no explicit USB headset indications for the attached USB headset. The following figure is an example of the **USB Device Status** screen.

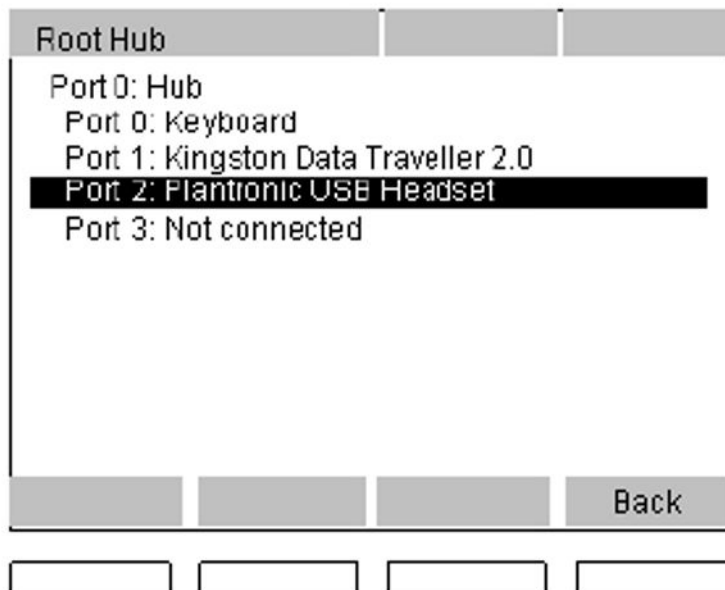


Figure 10: USB Device Status screen showing the presence of a USB headset

**Related links**

[USB headset](#) on page 67

**Audio format selection**

After the IP Deskphone receives the endpoint configurations, it searches the records to select an audio format that matches the IP Deskphone requirements. If no match is found, then the default audio format is used. After you select the format, the IP Deskphone sends a command to the device to select the corresponding endpoints for audio transfers.

The IP Deskphone supports both 8KHz and 16KHz audio. You can select the 16KHz audio, if the headset supports it. The IP Deskphone is a mono device with only one voice channel. For stereo USB headsets detected, the IP Deskphone replicates one channel voice data to both left and right channels of the headsets to simulate stereo output. The following table lists the audio format requirements supported by the IP Deskphone.

Audio Parameters	Values
Audio Format	PCM only
Subframe size	2
Bit Resolution	16 bits
Frequency Type	Continuous (0) or Discrete (> 0)
Sample Frequency	If Continuous, default to 16 KHz. If Discrete, 8 KHz, 16KHz or 8KHz multiple. Preference is given to 16KHz audio, if supported
Audio Channel	Mono (1) or Stereo (2)

After you select the format and the Set Interface command is sent, the USB headset runs in Generic Mode 1 operation (both audio and HID) or Mode 2 operation (audio only). If the headset runs in Mode 1 operation, the IP Deskphone configures the task or callback to communicate with the USB HID control events between the IP Deskphone and the headset. You can insert the headset during an active call. The IP Deskphone synchronizes the headset state machine of the IP Deskphone to the current state of the headset to ensure the LED match status.

During the call, if the audio negotiated between the two parties is set to 8KHz audio and the IP Deskphone is setup for 16KHz USB Headset audio, the IP Deskphone performs the transcoding between 8KHz audio to 16KHz audio. Likewise, if the audio negotiated between the two parties is set to 16KHz audio and the headset supports only 8KHz audio, the IP Deskphone performs the transcoding between 16KHz audio to 8KHz audio.

#### Related links

[USB headset](#) on page 67

---

## Generic USB headset

When a generic USB headset (or supported headset with HID command disabled) is attached to the IP Deskphone and selected, it behaves like a wired headset. All call controls, on hook, off hook, mute, volume up, and volume down are performed using the keys on the IP Deskphone. The IP Deskphone does not use the User interface elements on the headset, including LEDs if present. When the USB headset is selected, the voice path to or from the USB headset is used in an active call.

#### Related links

[USB headset](#) on page 67

---

## Avaya USB headset adapter with HID

When you enable the HID support for Avaya USB Mobile or Enhanced adapter, then the IP Deskphone makes use of the UI elements on the adapter. Both type of USB headsets are stimulus devices, as the IP Deskphone can have complete control of the LEDs. The following table lists the features of the Avaya USB headset Adapter.

**Table 9: Avaya USB headset adapter with HID support**

Feature	Description
Key Event	<p>Key press on the adapter generates events only with a state maintained and actions taken by the IP Deskphone. There is a one-to-one mapping on most of the keys on the adapter to the keys on the IP Deskphone (the Avaya Enhanced Adapter has a Avaya logo key which does not exist on the IP Deskphone). <a href="#">Avaya USB adapter key mappings</a> on page 70 illustrates the mappings.</p> <p>Key press events on the adapter are sent to the IP Deskphone through the USB. When the IP Deskphone receives these events, it maps them to the corresponding key events as if the keys on the IP Deskphone are pressed.</p>
LED	<p>There are two LEDs on the adapters: one for the mute status and the other for message waiting. These two LEDs are also mapped to the corresponding LEDs on the IP Deskphone. The IP Deskphone synchronizes the LEDs status with that of the IP Deskphone — the Mute LED for mute indication and the Message Waiting LED for message waiting and incoming call (flash) indications. The Avaya USB Enhanced Adapter has an extra port to connect an external alerter. If there is an external alerter attached, the external alerter is kept synchronized with the Message Waiting LED.</p>
Attached Indicator	<p>When an Avaya USB Mobile or Enhanced Headset is connected to the IP Deskphone, after enumeration, the IP Deskphone flashes the LEDs on the headset for a short duration to indicate the headset is ready to use.</p>
Back Light	<p>Both adapters have a back light to allow easy identification of the adapters. If the back light is enabled in the Headset screen, the back light of the adapter turns on after enumeration.</p>
Message Waiting	<p>If there is a voice message waiting on the IP Deskphone, the IP Deskphone turns on the red Message Waiting LED on the IP Deskphone and on the adapter. The IP Deskphone turns off the red Message Waiting LED if there is no voice message waiting.</p>
External Alerter	<p>The Avaya USB Enhanced Adapter has a port to allow an External Alerter (large LED indicator) to attach to the adapter. The IP Deskphone uses HID commands to keep the External Alerter synchronized</p>

*Table continues...*

Feature	Description
	with the red Message Waiting LED on the IP Deskphone and on the adapter.
Incoming Call	When there is an incoming call, the IP Deskphone sends an alerting event to the adapter. The red Message Waiting LED flashes to indicate there is an incoming call on the IP Deskphone.
Caller ID Information	Not applicable.
Call Answer	You can answer an incoming call by pressing the Headset key on the IP Deskphone or the Off Hook (Green) key on the adapter. After a call is answered, audio data flows between the IP Deskphone and the headset adapter through the USB port.
Outgoing Call	You can make an outgoing call by either pressing the Headset key on the IP Deskphone, or the Off Hook (Green) key on the adapter. When off hook, the IP Deskphone streams dial tone to the headset. The telephone number must be dialed using the key pad of the IP Deskphone. After a call is answered, audio data flows between the IP Deskphone and the headset adapter through the USB port.
Call Release	You can release an incoming call or an outgoing call by pressing either the On Hook (Red) key on the adapter, or the Release (Goodbye) key on the IP Deskphone. After a call is released, audio data between the IP Deskphone and the headset stops.
Call Mute	Pressing the <b>Mute</b> key on the adapter is equivalent to pressing the <b>Mute</b> key on the IP Deskphone. After processing the mute event, the voice path from the IP Deskphone to the far end is muted. Both the Mute LED on the IP Deskphone and the LED on the adapter are lit to indicate the call is muted. When unmuted, the voice path resumes and both LEDs go off.
Volume Up/Down	Pressing the Volume Up/Down key on the adapter is equivalent to pressing the Volume Up/Down key on the IP Deskphone. After processing the Volume Up/Down events, the system volume changes and affects the volume on the attached headset.
Audio Processing	Same as the wired headset. Audio quality is restricted to narrow band with mono voice channel only.

The following table lists the Avaya USB adapter key mappings.



**Table 10: Avaya USB adapter key mappings**

Keys on adapter	Keys on the IP Deskphone
Blue Key	Expand Key
Green Key	Headset Key
Red Key	Release Key
Mute Key	Mute Key
Volume Up/Down	Volume Up/Down

The Blue key is mapped to the Expand key on the IP Deskphone. Therefore, pressing the Blue key invokes the Instant Messaging screen.

**Related links**

[USB headset](#) on page 67

**Third-party USB headsets with HID**

Both USB Audio and USB HID commands are supported. The two classes of third-party USB headsets are as follows:

- Plantronics CS50/CS60 Wireless USB headsets
- GN Netcom 9300 series wired and wireless USB headsets

The HID support of third-party USB headsets performs differently from the Avaya Headset. The headsets are independent devices with an internal state machine to control LED operations and headset behavior.

The following table lists the features of a third-party USB headset with HID support.

**Table 11: Third-party USB headset with HID support features**

Feature	Description
Key Events	<p>Both types of headsets have equivalent mechanisms to generate the following key events:</p> <ul style="list-style-type: none"> <li>• On Hook</li> <li>• Off Hook</li> <li>• Mute</li> <li>• Volume Up/Down</li> </ul> <p>The headsets send the corresponding HID commands to the IP Deskphone to synchronize call processing operations. When the IP Deskphone receives these commands, the IP Deskphone maps them to the corresponding key events (except the</p>

*Table continues...*

Feature	Description
	<p>Volume Up/Down keys) as if the keys on the IP Deskphone are pressed.</p> <p>If the corresponding keys on the IP Deskphone are used instead, the IP Deskphone sends the HID commands to the headsets to allow the headsets to update their internal state machine.</p>
LEDs	<p>Both types of headsets have LEDs on the base station for status indication. These LEDs are controlled by the headset base stations themselves according to their internal state machines. The IP Deskphone has no direct control of these LEDs.</p>
Attached Indicator	<p>Both types of headsets can have attached indications independent of the IP Deskphone operations.</p> <p>The GN Netcom (Jabra) 9350 headset can take over 3 seconds to complete the enumeration process after the headset is attached to the IP Deskphone. During enumeration, the LEDs at the bottom of the base station flash. The enumeration process is complete only when there is a blink at the headset piece and the base LEDs become solid.</p>
Back Light	Not applicable
Message Waiting	Not applicable
External Alerter	Not applicable
Incoming Call	<p>When there is an incoming call, the IP Deskphone sends an alerting event to the headset. Each type of headset has different incoming call indications.</p>
Caller ID Information	Not applicable
Call Answer	<p>You can answer an incoming call by pressing the Headset key on the IP Deskphone or the Off Hook equivalent key on the headset. The IP Deskphone coordinates the key events from both sources and performs the necessary call processing operations. Call connected indications, if available, are autonomous within the headset to match its internal state. After a call is answered, audio data flows between the IP Deskphone and the headset through the USB.</p>
Outgoing Call	<p>You can make an outgoing call by either pressing the Headset key on the IP Deskphone or the Off Hook equivalent key on the headset. When off hook, the IP Deskphone streams dial tone to the headset. This class of headset has no dial pad and the telephone number must be dialed using the key pad of the IP</p>

*Table continues...*

Feature	Description
	Deskphone. After the call is connected, voice data streams between the IP Deskphone and the headset.
Call Release	<p>You can release an incoming call or an outgoing call by pressing either the Release (Goodbye) key on the IP Deskphone or the On Hook equivalent key on the headset. After a call is released, audio data stops between the IP Deskphone and the headset.</p> <p>If you are using the Plantronic headset, to release a call, press and hold the answer/release toggle button for more than two seconds.</p>
Call Mute	The mute key event is handled independently on the headset. The corresponding HID command is sent to the IP Deskphone to synchronize IP Deskphone status. Mute status indication on the headset is also independent. When muted, the headset streams blank audio to the IP Deskphone and the IP Deskphone also mutes the audio to the far end (double muted).
Volume Up/Down	This class of headsets manages volume changes locally whenever Volume Up/Down keys are pressed. Pressing the Volume Up/Down keys on the headset has no effect on system volume. The IP Deskphone ignores volume events from the headsets to avoid double volume changes. On the other hand, volume changes on the IP Deskphone change the system setting and indirectly affects the volume level on the headset.
Audio Processing	Same as the wired headset. Both headsets support Wideband audio. The IP Deskphone selects to use 16KHz audio to match the audio characteristics of the headset.

**Related links**

[USB headset](#) on page 67

## Analog Terminator Adapter for analog (500/2500-type) telephone or fax machine

SIP Software Release 3.x and later supports the Analog Terminator Adapter (ATA) which is connected using the USB port. An analog (500/2500-type) telephone or fax machine can be connected to the ATA to convert the IP Deskphone to an analog system. The ATA is treated as an USB Headset device by the IP Deskphone.

SIP Software 3.x and later supports On hook/Off hook and dial pad key events for HID support to allow the attached device to make outgoing calls directly without using the key pad on the IP

Deskphone. If Calling Line ID (CLID) of the far-end is available, then the information is sent to the attached analog device. An analog (500/2500-type) telephone or fax machine that supports Calling Line ID displays the information on the screen.

The following table displays the characteristics of ATA.

**Table 12: Summary of ATA characteristics**

Feature	Description
Key Events	In addition to On hook, Off hook events, dial pad digit events from the attached analog device are also supported. Key press events on the adapter are sent to the IP Deskphone through the USB. After the IP Deskphone receives these events, it maps them to the corresponding key events as if the keys on the IP Deskphone are pressed.
LEDs	Not applicable.
Attached Indicator	Not applicable.
Back Light	Not applicable.
Message Waiting	Not applicable.
External Alarmer	Not applicable.
Incoming Call	When there is an incoming call, the IP Deskphone sends an alerting event to the adapter. The adapter produces the ring tones for the attached analog device to indicate there is an incoming call on the IP Deskphone.
Caller ID Information	Caller ID, if available, is also sent to the adapter. The adapter sends the CLID to the attached analog device for display.
Call Answer	You can answer an incoming call by pressing the Headset key on the IP Deskphone or the Off Hook key on the attached analog device. After a call is answered, the adapter converts the digital voice data to analog and sends it to the attached analog device.
Outgoing Call	You can make an outgoing call by either using the Headset key on the IP Deskphone or the Off Hook key on the attached analog device. When off hook, the IP Deskphone streams dial tone to the adapter. The telephone number can be dialed using the key pad of the IP Deskphone or the key pad of the analog device. After a call is answered, the adapter converts the digital voice data to analog and sends it to the attached analog device.
Call Release	You can release an incoming call or an outgoing call by either pressing the Release (Goodbye) key on the IP Deskphone or On Hook key on the analog device.

*Table continues...*

Feature	Description
Call Mute	The analog device may have a mute key to stop voice transmission; however, the Mute key event on the analog device is not supported.
Volume Up/Down	The Volume Up/Down key on the analog device, if available, is independent of the IP Deskphone operation.
Audio Processing	Same as the wired headset. Audio quality is restricted to narrow band with mono voice channel only.

**Related links**

[USB headset](#) on page 67

# Chapter 7: Making a call

This section describes the methods you can use to make a call. You can make a call from your IP Deskphone using one of the following:

- [Making a call using off-hook dialing](#) on page 78
- [Making a call using on-hook dialing](#) on page 79

You can also initiate a call while using one of the following features:

- [The Address Book](#) on page 88
- [Call Inbox](#) on page 96
- [Call Outbox](#) on page 102
- [Instant Messaging](#) on page 105

When an outgoing call fails to connect to the destination, one of the following messages appears:

- Declined, Temporarily unavailable
- Declined, Cannot find user

## Related links

[Making a call using off-hook dialing](#) on page 78

[Making a call using on-hook dialing](#) on page 79

[Using Call Subjects](#) on page 81

[Managing Call Subjects](#) on page 82

---

## Making a call using off-hook dialing

### To make a call using off-hook dialing:

1. Make a call by using one of the following off-hook dialing methods:
  - Press the **Line** feature key
  - Lift the handset
  - Press the **Headset** fixed key
  - Press the **Handsfree** fixed key

The IP Deskphone produces a dial tone.

2. You can make a call using one of the following methods:

Enter the phone number or SIP address by using the dialpad.

**\* Note:**

The **abc/123** soft key toggles between alphabetic and numeric input.

**OR**

Press the **Redial** soft key to dial the last dialed number.

**\* Note:**

The **Redial** context-sensitive soft key only appears if a number or address was previously entered.

**OR**

Press the **Msgs** soft key and then select **Voice Mail** from the **Messages** menu to access your voice mail.

**OR**

Press the **Speed dial** feature key that you programmed to call with a commonly used or important phone number or SIP address.

**\* Note:**

You can program a feature key to use as a shortcut to dial a number or a SIP address. For more information, see [Feature keys](#) on page 125.

3. Press the **Send** soft key to immediately initiate the call.

**\* Note:**

The IP Deskphone automatically initiates a call shortly after you enter the SIP address or phone number.

#### Related links

[Making a call](#) on page 78

---

## Making a call using on-hook dialing

You can make a call by using on-hook dialing. Enter the SIP address or the phone number before going off-hook.

**\* Note:**

When you use this method, you cannot toggle between alphabetic or numeric input.

#### To make a call using on-hook dialing:

1. Dial the number or SIP address.
2. Continue the call by using one of the following methods:
  - Press the **line** feature key.
  - Press the **Headset** fixed key.

## Making a call

- Press the **Handsfree** fixed key.
3. To terminate the call, choose one of the following:
    - Replace the handset into the cradle.
    - Press the **Goodbye** key.

### Related links

[Making a call](#) on page 78

[Using handsfree calling](#) on page 80

---

## Using handsfree calling

While on an active call, you can switch between the handset, headset, and handsfree mode.

### To end a handsfree call:

Press the **Goodbye** key.



### To mute a handsfree call:

1. Press the **Mute** key. The LED indicator lights.



2. Press the **Mute** key again to return to a two-way handsfree conversation.

### To switch from the handsfree to handset mode:

Lift the handset.

### To switch from the handset mode to handsfree mode:

1. Press the **Handsfree** key. The LED indicator lights with a solid red light.



2. Replace the handset.

### To use a headset:

1. Connect the headset to the headset jack.
2. Press the **Headset** key. The LED indicator lights.



3. Press the **Goodbye** key or press the button on the wireless headset, if equipped, to release a call.

### To switch from handsfree to headset:

Press the **Headset** key. The LED indicator lights.



**Related links**

[Making a call using on-hook dialing](#) on page 79

---

## Using Call Subjects

You have the option of sending a Call Subject when you initiate a call to a contact. Use this feature to indicate to the contact the reason for the call. The IP Deskphone contact displays a message, such as “**Weekly report call**” or “**Daily status**” when they receive the call. You can select a subject from a list you create or you can create a new subject.

**\* Note:**

The Call Subject feature is not available for all call servers. Contact your system administrator or service provider to determine if this feature is available to you.

Whenever you initiate a call by using off-hook dialing, the **Subject** soft key appears as an option to use. You can select a Call Subject from a list or create a new Call Subject to send.

### To enter a call subject from a list:

1. Press the **Subject** soft key to send a Call Subject with the call you are making.  
A list of Call Subjects appears on the LCD screen.
2. Press the **Up/Down** navigation key to highlight the Call Subject you want to use and press the **Select** soft key. The IP Deskphone sends the Call Subject to the contact you are calling.

**OR**

Press the **New** soft key to create a new Call Subject that is not on the list.

3. Press the **abc/123** soft key to toggle between alphabetic and numeric characters.
4. Use the dialpad to enter the Call Subject.
5. Press the **Save** soft key to continue.

**OR**

Press the **Clear** soft key to clear the text.

**OR**

Press the **Back** soft key to return to the previous menu.

**\* Note:**

When you select a subject from this list, it appears on the screen before you send the call. If you want to change that subject, press the **Subject** soft key to return to the Call Subject menu. You now have the option to select **No** for a Call Subject.

### To create a new call subject while initiating a call:

1. Press the **Subject** soft key to send a Call Subject with the call you are making.
2. Press the **New** soft key to create a new Call Subject.
3. Press the **abc/123** soft key to toggle between alphabetic and numeric characters.

4. Use the dialpad to enter the new Call Subject for the contact.
5. Press the **Save** soft key to save the new Call Subject and use it with the call.

**OR**

Press the **Clear** soft key to clear the text.

**OR**

Press the **Back** soft key to return to the previous menu without sending the new Call Subject.

#### Related links

[Making a call](#) on page 78

---

## Managing Call Subjects

You can create a list of Call Subjects to have ready to use when you initiate a phone call. The number of Call Subjects that are stored on the IP Deskphone depends on how the IP Deskphone was initially configured. You can modify, delete, and add Call Subjects while the IP Deskphone is in the idle state.

#### Related links

[Making a call](#) on page 78

[Adding a Call Subject](#) on page 82

[Deleting a Call Subject](#) on page 83

[Editing a Call Subject](#) on page 83

---

## Adding a Call Subject

You can add a Call Subject while the IP Deskphones is idle.

#### To add a Call Subject while the IP Deskphone is idle:

1. Press the **Prefs** soft key, select **Feature Options**, and then select **Call Subject** from the menu.
2. Press the **Add** soft key to create new Call Subject.

**\* Note:**

If the Call Subject list is full, then the option to add a new Call Subject is not available. In this situation, you need to delete a Call Subject before you can add the new Call Subject.

3. Press the **abc/123** soft key to toggle between alphabetic and numeric characters.
4. Use the dialpad to enter the new Call Subject.
5. Press the **Save** soft key to add the new Call Subject.

**OR**

Press the **Back** soft key to return to the previous menu without adding a new Call Subject.

#### Related links

[Managing Call Subjects](#) on page 82

---

## Deleting a Call Subject

You can delete a Call Subject while the IP Deskphone is idle.

#### To delete a Call Subject while the IP Deskphone is idle:

1. Press the **Prefs** soft key, select **Feature Options**, and then select Call Subject from the menu.
2. Press the **Up/Down** navigation key to scroll through and highlight the Call Subject to delete.
3. Press the **Delete** soft key to delete the selected Call Subject.

A confirmation screen appears with the question, `Delete call subject?`

4. Press the **Ok** soft key to confirm the deletion of the Call Subject.

**OR**

Press the **Back** soft key to not delete the Call Subject and return to the previous menu.

#### Related links

[Managing Call Subjects](#) on page 82

---

## Editing a Call Subject

You can edit a Call Subject while the IP Deskphone is idle.

#### To edit a Call Subject while the IP Deskphone is idle:

1. Press the **Prefs** soft key, select **Feature Options**, and then select **Call Subject** from the menu.
2. Press the **Up/Down** navigation key to scroll through and highlight the Call Subject to edit.
3. Press the **Edit** soft key to edit the selected Call Subject.
4. Press the **abc/123** soft key to toggle between alphabetic and numeric characters.
5. Use the dialpad to edit the Call Subject.
6. Press the **Save** soft key to confirm the changes.

**OR**

Press the **Back** soft key to return to the previous menu without editing the Call Subject.

#### Related links

[Managing Call Subjects](#) on page 82

# Chapter 8: Receiving a call

When you receive a call, you are typically notified by the alerting ring, and the incoming caller identification appears on the LCD screen. The incoming call forces the screen to exit active menu activities and takes precedence over a pop-up Instant Message (IM).

## Related links

[Caller identification](#) on page 84

[Answering an incoming call](#) on page 84

[Redirecting an incoming call](#) on page 85

[Ignoring an incoming call](#) on page 86

---

## Caller identification

When you receive an incoming SIP call, the Caller ID information appears on the IP Deskphone display screen. When you receive a call from a contact that is entered in the IP Deskphone Address Book, the caller information appears as it is in the Address Book.

You can restrict the information displayed for incoming calls or for calls you make by configuring the privacy settings..

When you receive an incoming call, you can do one of the following:

- Answer an incoming call.
- Redirect an incoming call.
- Ignore an incoming call.
- Receive an intercom call.
- Receive paging calls.

## Related links

[Receiving a call](#) on page 84

---

## Answering an incoming call

When you can answer an incoming call, you can choose one of four methods.

**To answer an incoming call:**

1. Press the **Answer** soft key that activates a Handsfree call.
2. Lift the handset.
3. Press the **Headset** fixed key.



4. Press the **Handsfree** fixed key.

**Related links**

[Receiving a call](#) on page 84

---

## Redirecting an incoming call

When you receive a call, you can choose to redirect the call to another destination without answering the call.

To redirect a call, press the **Redrct** soft key. To enter a SIP address or phone number where you want the call redirected, use one of the following methods:

- Enter the SIP address or phone number by using the dialpad.
- Select a contact from the Address Book, Call Inbox, or Call Outbox.

**To redirect an incoming call by using the dialpad:**

1. Press the **Redrct** soft key to redirect an incoming call.  
The LCD screen prompts you to enter an address to which you want the call directed.
2. Use the **Dialpad** to enter a phone number or SIP address.

**\* Note:**

Do not use the # key to end dialing when you redirect a call. The call returns a busy signal and does not connect.

3. Press the **Redrct** soft key.

**OR**

Press the **Clear** soft key to clear the entry.

**OR**

Press the **Back** soft key to return to the **Incoming Call** screen without redirecting the call.

**To redirect a call by using the Address Book, Call Inbox, or Call Outbox:**

1. Press the **Redrct** soft key to redirect an incoming call.

2. To select a SIP address to redirect the call, do one of the following:
  - Press the **Directory** fixed key to choose a SIP address from the Address Book.
  - Press the **Msg/Inbox** fixed key to choose a SIP address from the Call Inbox.
  - Press the **Shift/Outbox** fixed key to choose a SIP address from the Call Outbox.
3. Press the **Up/Down** navigation key to highlight a SIP address contact.
4. Press the **Select** soft key to select the highlighted SIP address.

**OR**

Press the **Back** soft key to return to the previous screen.

5. Press the **Redrct** soft key to redirect the incoming call to the selected address.

**Related links**

[Receiving a call](#) on page 84

---

## Ignoring an incoming call

You can terminate an incoming call alert without answering the call by pressing the **Ignore** soft key or by pressing the **Goodbye** fixed key. The caller continues to hear the ringing tone but is unaware that you are ignoring the call.

You can configure the **Call Ignore** feature to either Local or Network. When Call Ignore is configured to Local, only that IP Deskphone is affected, and it stops ringing when you press the **Ignore** soft key. When Call Ignore is configured to Network and you press the **Ignore** soft key, the IP Deskphone stops ringing, and a message is sent to the network indicating that you are busy at all SIP IP Deskphones you are logged on to, and that server should stop trying to contact you.

To configure the Ignore feature to Local or Network press the **Prefs** soft key, select **Feature Options**, and then select **Call Ignore Action** from the menu. Press the **Change** key to change the Call Ignore setting to either **Call Ignore: Local**, or **Call Ignore: Network**.

**\* Note:**

When you are on active call and you receive an incoming call, do not press the **Goodbye** fixed key to ignore an incoming call. If you press the **Goodbye** fixed key, the current call disconnects. Press the **Ignore** soft key to ignore the incoming call.

**To ignore an incoming call:**

1. Press the **Prefs** soft key, select **Feature Options**, and then select **Call Ignore Action** from the menu.
2. Press the **Change** key to change the Call Ignore setting to either **Call Ignore: Local** or **Call Ignore: Network**.
3. Press the **Ignore** soft key to terminate an incoming call.

**OR**

Press the **Goodbye** fixed key when you are not on an active call.

**Related links**

[Receiving a call](#) on page 84

# Chapter 9: The Address Book

The Address Book is a personal directory of contacts from which you can make a phone call or send an Instant Message (IM). You can access the Address Book while on a call and start a new call from the highlighted contact. You can use the Address Book for the following:

## Related links

- [Viewing the Address Book](#) on page 88
- [Initiating a call from the Address Book](#) on page 88
- [Adding a contact to your Address Book](#) on page 89
- [Editing a contact in your Address Book](#) on page 90
- [Copying information to the Address Book](#) on page 91
- [Searching for a contact in the Address Book](#) on page 92

---

## Viewing the Address Book

To access the Address Book, press the **Directory** fixed key or press the **View** soft key, and then select **Address Book** from the menu.

To view information about a contact, use the navigation button to highlight a name, and then press the **View** soft key. The name, SIP address, and designation of the contact as Friend or not is displayed.

When you view the details of a contact, you can:

- Initiate a call from the Address Book to the contact..
- Send an IM.
- Edit the contact information.

## Related links

- [The Address Book](#) on page 88

---

## Initiating a call from the Address Book

You can initiate a call directly from your IP Deskphone Address Book.



**\* Note:**

If your service provider requires that a Directory Number (DN) be used to initiate a call, the Address Book entry must have the DN to initiate a call.

First, go off-hook. If needed, you can add a Call Subject.

You can also access the Address Book while on an active call and initiate a new call. The IP Deskphone automatically places the active call on hold when you initiate a new call.

**To initiate a call to a contact stored in the Address Book:**

1. Press the **Directory** fixed key to select a contact from the Address Book to call.
2. Press the **Up/Down** navigation key to highlight a contact on the list.
3. Press the **View** soft key to open the contact information..
4. Press the **Call** soft key to make a call to the contact.

**OR**

Press the **Back** soft key to return to the off-hook screen.

**Related links**

[The Address Book](#) on page 88

## Adding a contact to your Address Book

You can add a new contact to the Address Book of the IP Deskphone.

**To add a contact to your Address Book:**

1. Press the **Directory** fixed key.

**OR**

Press the **View** soft key, select **Address Book** from the menu, and then press the **Add** soft key.

2. Press the **abc/123** soft key to toggle between alphabetic and numeric characters.
3. Use the dialpad to enter a name for the new contact and press the **Next** soft key to continue.

**OR**

Press the **Back** soft key to return to the previous menu.

4. Use the dialpad to enter a phone number or SIP address (URI) for the new contact. Press the **Next** soft key to continue or press the **Back** soft key to return to the previous menu.
5. Press the **Yes** soft key to designate the contact as a friend.

**OR**

Press the **No** soft key if you do not want to designate the contact as a friend.

6. Press the **Yes** soft key to add the contact to a group and then select the group.

**OR**

Press the **No** soft key if you do not want the contact added to a group.

**OR**

Press the **Back** soft key to return to the previous menu.

7. Press the **Ok** soft key to complete the entry and return to the Address Book menu.

#### Related links

[The Address Book](#) on page 88

---

## Editing a contact in your Address Book

You can edit a contact in your Address Book.

#### To edit a contact in your Address Book:

1. Press the **Directory** fixed key.
2. Press the **Up/Down** navigation key to highlight the contact you want to edit, and then press the **View** soft key.
3. Press the **Edit** soft key to edit the contact information.
4. Press the **abc/123** soft key to toggle between alphabetic and numeric characters.
5. Use the dialpad to enter new information for the contact.
6. Press the **Next** soft key to continue.

**OR**

Press the **Back** soft key to return to the previous menu.

#### **Note:**

If you only need to change one field for the contact, press the **Next** soft key without making changes.

7. Press the **Yes** soft key to designate the contact as a friend and return to the address menu screen.

**OR**

Press the **No** soft key if you do not want a contact designated as a friend and return to the address menu screen.

#### **Note:**

If the contact is already designated as a friend, then the question

`Remove from friends?`

appears. Press the **Yes** soft key to remove the contact from your friends list or press the **No** soft key to keep the contact in your friends list.

8. Press the **Ok** soft key to complete the entry and return to the previous menu.

**To delete a contact from your Address Book:**

1. While in the Address Book, press the **Up/Down** navigation key to highlight the contact you want to delete and press the **View** soft key.
2. Press the **Edit** soft key to access the contact information.
3. Press the **Delete** soft key to completely delete the contact from the Address Book.
4. Press the **Ok** soft key to confirm.

**OR**

Press the **Back** soft key to return to the previous menu.

5. Press the **Ok** soft key to complete the procedure and return to the Address Book.

**Related links**

[The Address Book](#) on page 88

---

## Copying information to the Address Book

To copy information from the **Call Inbox** or the **Call Outbox** screen to the Address Book, use the **Copy** fixed key.

 **Note:**

If you press the **Copy** fixed key while in idle mode, the message

`No content selected for copying`

appears on the screen. This message does not appear when an IM pop-up appears.

**To copy a contact to the Address Book:**

1. Press the **Up/Down** navigation key to highlight the contact in the Call Inbox or Call Outbox that you want to add to your Address Book and press the **Copy** fixed key.

A new screen appears offering the following destinations for the contact information:

- 1. Address Book
- 2. Speed Dial Key
- 3. Send IM Key
- 4. Call Forward Key

2. Press the **Up/Down** navigation key to highlight the Address Book and press the **Select** soft key.
3. Press the **abc/123** soft key to toggle between alphabetic and numeric characters.
4. Use the dialpad to enter a name for the entry.
5. Press the **Next** soft key to continue.

**OR**

Press the **Back** soft key to return to the previous menu.

**\* Note:**

- If you do not need to change the name for the contact, press the **Next** soft key.
6. Use the dialpad to enter a new phone number or new SIP address for the contact.  
Press the **Next** soft key after each entry to continue or press the **Back** soft key to return to the previous menu.
  7. Press the **Yes** soft key to designate the contact as a friend.  
**OR**  
Press the **No** soft key if you do not want to designate the contact as a friend.
  8. Press the **Yes** soft key to add the contact to a group and then select the group.  
**OR**  
Press the **No** soft key if you do not want the contact added to a group.  
**OR**  
Press the **Back** soft key to return to the previous menu.
  9. Press the **Ok** soft key to complete the entry and return to the Address Book menu.

**Related links**

[The Address Book](#) on page 88

---

## Searching for a contact in the Address Book

When you access the IP Deskphone Address Book you can perform a search for a contact using one of the following methods:

- Index Search (performs a search based on the index number you enter).
- 1st Character Search (performs a search based on the first character you enter; not case-sensitive).
- Name Search (performs a search based on the name you enter; not case-sensitive).

**To change the method the IP Deskphone uses to search:**

1. Press the **Prefs** soft key, and select **Misc Options > Search Method**.
2. Press the **Change** soft key.
3. Press the **Up/Down** navigation key to highlight the Search Method you want to use as the default when you search for a contact:
  - Index Search
  - 1st Character Search
  - Name Search
4. Press the **Select** soft key to select a search method, and then return to the previous menu.

You can search for a contact that is in your IP Deskphone Address Book (Local Search) or for a contact in a directory that is stored on the call server (Global Search). You can save a contact name

and SIP address found on the call server to your personal Address Book stored in your IP Deskphone.

### Related links

[The Address Book](#) on page 88

[Using the Search feature in the Address Book](#) on page 93

---

## Using the Search feature in the Address Book

To search for a contact while accessing your personal Address Book, use the dialpad to enter the search information. For example:

- **Index Search** — to search for a contact by using the Index Search method, enter the index number. When entering an index number larger than 9, you must enter the next digit quickly to move to that item on the list. For example, if the address you need is item 28 on the list, you must enter the digit 8 quickly after entering the digit 2. The found contact is highlighted and then opened.
- **1st Character Search** — searches records by only one character. To search for a contact whose name begins with a letter, for example the letter d, press the d (3) key on the dialpad. The first entry in the Address Book that begins with the letter d appears.
- **Name Search** — to search for a specific name in your personal Address Book, enter the name by using the dialpad. You can enter a maximum of 8 characters.

### **Note:**

1st Character Search and Name Search are not case-sensitive.

You can search for a contact that is in your IP Deskphone Address Book (Local Search) or for a contact in a directory that is stored on the call server (Global Search). You can save a contact name and SIP address found on the call server to your personal Address Book stored in your IP Deskphone.

### Related links

[Searching for a contact in the Address Book](#) on page 92

[Using Local Search](#) on page 93

[Using Global Search](#) on page 94

## Using Local Search

You can search for a contact that is stored in your Address Book.

### To search for a contact stored in your Address Book:

1. Press the **Services** fixed key, select **Search**, and then select **Local Search** from the menu.
2. Press the **Up/Down** navigation key and then press the **Select** soft key to choose a search criteria:
  - User Name
  - Name

- Phone Number
3. Press the **abc/123** soft key to toggle between alphabetic and numeric characters.
  4. Use the dialpad to enter the search information for the contact.

Press the left arrow to delete characters; press the right arrow to enter a space.

**\* Note:**

The search is not case-sensitive.

5. Press the **Search** soft key.

**OR**

Press the **Back** soft key to return to the previous menu.

**\* Note:**

When the search is unsuccessful, the following message appears:

No entries found for <search criteria>.

6. If a search result is successful, you can do one of the following:
  - Press the **Up/Down** navigation key to highlight a contact, from the search result and press the **Call** soft key to initiate a call.
  - Press the **Search** soft key to start a new search.
  - Press the **Exit** soft key to return to the idle screen.
7. If a search result is not successful, you can do one of the following:
  - Press the **Search** context-sensitive soft key to return to the search menu and begin a new search.
  - Press the **Exit** context-sensitive soft key to return to the idle screen.

## Related links

[Using the Search feature in the Address Book](#) on page 93

## Using Global Search

You can perform a Global Search for a contact.

### To perform a Global Search for a contact:

1. Press the **Services** fixed key, select **Search**, and then select **Global Search** from the menu.
2. Press the **Up/Down** navigation key and then press the **Select** soft key to choose a search criteria:
  - User Name
  - First Name
  - Last Name
  - Phone Number
3. Press the **abc/123** soft key to toggle between alphabetic and numeric characters.

4. Use the dialpad to enter the search information for the contact.  
Press the left arrow to delete a character; press the right arrow to enter a space.

**\* Note:**

The search is not case-sensitive.

5. Press the **Ok** soft key.

**OR**

Press the **Back** soft key to return to the previous menu.

**\* Note:**

When the search is unsuccessful, the following message appears:

```
No entries found for <search criteria>.
```

6. When a search result is successful, you can do one of the following:
  - Press the **Up/Down** navigation key to highlight a contact from the search result and press the **Call** soft key to initiate a call.
  - Press the **Save** soft key to save the caller information to the Address Book.

A confirmation screen appears. You can edit the name you save in the Address book. Press the **Save** soft key to accept the entry. Press the **Yes** soft key or the **No** soft key to designate whether the new entry is a friend. The phone saves the entry to the Address Book and returns you to the Inbox screen.

7. Press the **Search** soft key to start a new search.

**OR**

Press the **Back** soft key to return to the previous screen.

8. When a search result is not successful, you can do one of the following:
  - Press the **New** soft key to return to the search menu and begin a new search.
  - Press the **Back** soft key to return to the previous screen.

### Related links

[Using the Search feature in the Address Book](#) on page 93

# Chapter 10: Call Inbox and Call Outbox

This chapter provides information about the Call Inbox and Call Outbox.

## Related links

[Call Inbox](#) on page 96

[Call Outbox](#) on page 102

---

## Call Inbox

While your IP Deskphone is active, all incoming calls are saved in your Call Inbox. You can view the following details about each call:

- Call status (Missed)
- Name of the caller
- SIP address
- Time of the call
- Call Subject (if the caller sends a Call Subject)

You can configure the filter on your Call Inbox to display all incoming calls or missed calls. You can access your Call Inbox while the IP Deskphone is idle or while you are on a call. The following figure shows the Call Inbox while the IP Deskphone is idle.



**Figure 11: Call Inbox while IP Deskphone is idle**



**Related links**

- [Call Inbox and Call Outbox](#) on page 96
- [Accessing the Call Inbox](#) on page 97
- [Managing calls in the Call Inbox while not on a call](#) on page 97
- [Viewing the details of a call in the Call Inbox](#) on page 98
- [Managing missed calls](#) on page 99
- [Initiating a call from the Call Inbox](#) on page 100
- [Deleting calls in your Call Inbox](#) on page 101
- [Accessing the calls in your Call Inbox during a call](#) on page 101

---

## Accessing the Call Inbox

You can access the Call Inbox and initiate a call when the IP Deskphone is:

- idle
- active

**Related links**

- [Call Inbox](#) on page 96

---

## Managing calls in the Call Inbox while not on a call

You can manage calls in the Call Inbox while you are not on a call.

**To manage calls in the Call Inbox while not on a call:**

1. Press the **Msg/Inbox** fixed key.
2. Press the **Up/Down** navigation key to highlight a call from the list of calls in your Call Inbox.

 **Note:**

You can initiate a call to the highlighted caller.

3. To place a call to the selected address using the primary login of the IP Deskphone, press the **Enter** key.

**OR**

To view the details of a highlighted call, press the **Right** navigation key. .

**OR**

To leave the detail view and return to the main Inbox screen, press the **Left** navigation key.

Press the **Missed** soft key to toggle the view filter from the **All** soft key to the **Missed** soft key.

The **All** soft key is displayed when the view mode is on **Missed**, and displays all the calls in the Call Inbox.

**OR**

Press the **Delete** soft key to delete the highlighted call or all calls in your Call Inbox.

**OR**

Press the **Exit** soft key to exit the Call Inbox.

The following table provides a list of additional user interactions for the main Call Inbox screen.

**Table 13: Additional user interactions**

Function
Use the <b>Enter</b> key to place a call to the selected address using the primary login of the IP Deskphone. The <b>Enter</b> key has the same behavior as the <b>Call</b> soft key.
Use the <b>Dial pad</b> to select an item by index.
To place a call to the address of the selected call log entry from the primary logged in user of the IP Deskphone, do one of the following: <ul style="list-style-type: none"><li>• Lift the handset.</li><li>• Press the <b>Headset</b> fixed key.</li><li>• Press the <b>Handsfree</b> fixed key.</li></ul>
Press the <b>Line</b> key to place a call to the address of the selected call log entry from the user logged in on the selected line key.

**Related links**

[Call Inbox](#) on page 96

---

## Viewing the details of a call in the Call Inbox

**To view details of a call in the Call Inbox:**

Select the call in the Call Inbox and press the right navigation key.

When you view the details of a call in the Call Inbox, you can initiate a call to the caller displayed on the screen. Press the **Enter** key to place a call to the selected address using the primary login of the IP Deskphone.

Press the **Prev** soft key to select and display the details of the previous entry in the call log.

Press the **Next** soft key to select and display the details of the next entry in the call log.

Press the **Back** soft key to leave the detail view and return to the main inbox screen.

**Related links**

[Call Inbox](#) on page 96

## Managing missed calls

When you do not answer incoming calls, the number of new calls appears on the IP Deskphone display screen. For example, if you miss three calls, the following message appears:

```
3 new calls
```

**\* Note:**

When you view a missed call in your Call Inbox, the New Call message no longer appears on the telephone display screen. The new calls are stored as missed calls.

### To view missed calls:

1. Press the **Msg/Inbox** key and press the **Missed** soft key.
2. Press the **Up/Down** navigation key to highlight a call from the list of missed calls.
3. Press the **Right** soft key to view the details of the missed call.

**\* Note:**

You manage the missed call the same as any call that is in your Call Inbox.

4. To view all the calls in the Call Inbox, press the **All** soft key.
5. To delete the highlighted missed call or all missed calls, press the **Delete** soft key.

**\* Note:**

The IP Deskphone deletes only the missed calls from the Call Inbox.

6. To exit the Inbox and return to the idle phone screen, press the **Exit** soft key.

### Related links

[Call Inbox](#) on page 96

[Missed Calls Notification](#) on page 99

## Missed Calls Notification

You can change the call log behavior so that the message `xx new calls` is cleared by entering the Inbox without having to select each missed call.

### Changing the Missed Calls Notification behavior:

1. Press the **Prefs** soft key.
2. Select **Feature Options**, then **Missed Calls Notification**.
3. Press the **Select** soft key.

**OR**

Press the **Back** soft key to abort the changing of the configurations and return to the Message Options screen.

If you press the **Select** soft key, one of the following messages appears (based on the current setting of the option):

- Press **Manual** to change Missed Call Notification Message clearing mode
  - Press **Auto** to change Missed Call Notification Message clearing mode
4. Press the **Auto** soft key to change the clearing mode for the `thexx new calls missed call` message for the IP Deskphone.

**\* Note:**

**Auto** means that the message is cleared from the idle screen as soon as you enter the Inbox.

**OR**

Press the **Manual** soft key to change the clearing mode for the `the xx new calls missed call` message for the IP Deskphone.

**\* Note:**

**Manual** means that the message is cleared from the idle screen only after you look at the call detail for every newly missed call in the Inbox.

**Related links**

[Managing missed calls](#) on page 99

---

## Initiating a call from the Call Inbox

When you receive a call that is missed or answered, the calling number is listed in the Inbox. You can select the number, and then dial from the Inbox, or you can edit the number in the Inbox.

To initiate a call from the Call Inbox, press the **Msg/Inbox** fixed key and select **Inbox** from the menu.

**\* Note:**

- If your service provider requires that a Directory Number (DN) be used to initiate a call, the Call Inbox entry must have the DN to initiate a call.
- While you are on a call, you can initiate a new call from the Call Inbox.

**To initiate a call from the Call Inbox:**

1. Press the **Msg/Inbox** fixed key.
2. Press the **Up/Down** navigation key to highlight a call from the list of calls in your Call Inbox.
3. To view details of the call, press the **Right** navigation key.
4. To place a call to the selected address, do one of the following:
  - Lift the handset.
  - Press the **Headset** fixed key.

- Press the **Handsfree** fixed key.

#### Related links

[Call Inbox](#) on page 96

---

## Deleting calls in your Call Inbox

When you delete calls from the Call Inbox, both missed calls and answered calls are deleted. When you view the missed calls and select **Delete**, only the missed calls are deleted.

#### To delete calls from your Call Inbox:

1. Press the **Up/Down** navigation key to highlight a call from the list of calls in your Call Inbox.
2. Press the **Delete** soft key.
3. Select one of the following soft keys:
  - Press the **Yes** soft key to delete the highlighted call.
  - Press the **AllUsr** soft key to delete all the calls from the selected caller.
  - Press the **All** soft key to clear all calls from the Call Inbox.
  - Press the **No** soft key to return to the Inbox.

#### Related links

[Call Inbox](#) on page 96

---

## Accessing the calls in your Call Inbox during a call

You can access the calls in your Call Inbox while you are in an active call.

#### To access the calls in your Call Inbox during a call:

1. Press the **Up/Down** navigation key to highlight a call from the list of calls in your Call Inbox.
2. Press the **Enter** key to initiate a call to the highlighted caller.

#### **Note:**

This places the current call on hold, if it is not already on hold.

#### **OR**

Press the **Exit** soft key to return to the in-call screen.

#### Related links

[Call Inbox](#) on page 96

---

## Call Outbox

The Call Outbox keeps a record of all outgoing calls made from your IP Deskphone. You can add the contact details of the calls in your outbox to your Address Book. You can access the following details about the outgoing calls:

- Name
- Address
- Time of the call
- Number of Calls
- Call Subject (when used for a call)

### Related links

[Call Inbox and Call Outbox](#) on page 96

[Accessing the Call Outbox](#) on page 102

[Managing calls in the Call Outbox while not on a call](#) on page 102

[Accessing the calls in your Call Outbox during a call](#) on page 104

---

## Accessing the Call Outbox

You can access the Call Outbox and initiate a call when the IP Deskphone is:

- idle
- active

### Related links

[Call Outbox](#) on page 102

---

## Managing calls in the Call Outbox while not on a call

You can manage calls in the Call Outbox while you are not in an active call.

### To manage calls in the Call Outbox while not on a call:

1. Press the **Outbox** fixed key.
2. Press the **Up/Down** navigation key to highlight a call from the list of calls in your Call Outbox.
3. To view details of the selected call, press the **Right** navigation key.

### OR

To leave the detail view and return to the main inbox screen, press the **Left** navigation key.

4. Press the **Delete** soft key to delete the highlighted call.
5. Press the **Exit** soft key to return to the idle screen.

## Related links

[Call Outbox](#) on page 102

[Initiating a call from the Call Outbox](#) on page 103

[Deleting calls from your Call Outbox](#) on page 103

[Viewing the details of a call in the Call Outbox](#) on page 104

## Initiating a call from the Call Outbox

### \* Note:

If your service provider requires that a Directory Number (DN) be used to initiate a call, the Call Outbox entry must have a DN to initiate a call.

### To initiate a call from the Call Outbox:

1. Press the **Outbox** fixed key.



2. Press the **Up/Down** navigation key to highlight a call from the list of calls in your Call Outbox.
3. To view details of the selected call, press the **Right** navigation key.
4. You can initiate a call from the highlighted call in the Call Outbox list or from the details of a caller screen, by doing one of the following:
  - Lift the handset.
  - Press the **Headset** fixed key.
  - Press the **Handsfree** fixed key.
5. Press the **Call** context-sensitive soft key.

## Related links

[Managing calls in the Call Outbox while not on a call](#) on page 102

## Deleting calls from your Call Outbox

You can delete calls from your Call Outbox.

### To delete calls from your Call Outbox:

1. Press the **Up/Down** navigation key to highlight a call from the list of calls in your Call Outbox.
2. Press the **Delete** soft key.
3. Select one of the following soft keys:
  - Press the **Yes** soft key to delete the highlighted call.
  - Press the **AllUsr** soft key to delete all the calls from the selected caller.
  - Press the **All** soft key to clear all calls from the Call Outbox.
  - Press the **No** soft key to return to the Outbox.

### Related links

[Managing calls in the Call Outbox while not on a call](#) on page 102

## Viewing the details of a call in the Call Outbox

You can view details of a call in the Call Outbox.

### To view details of a call in the Call Outbox:

To view details of the selected call, press the **Right** navigation key.

When you view the details of a call in the Call Outbox, you can do one of the following:

- Initiate a call to the caller displayed on the screen.
- View a previous caller in the Call Outbox list by pressing the **Prev** soft key and return to the **Outbox** screen.
- View the next caller in the Call Outbox list by pressing the **Next** soft key and return to the **Outbox** screen.
- Press the **Back** context-sensitive soft key to return to the Outbox.

### Related links

[Managing calls in the Call Outbox while not on a call](#) on page 102

---

## Accessing the calls in your Call Outbox during a call

You can access the calls in your Call Outbox during an active call.

### To access the calls in your Call Outbox during a call:

1. To access the calls in your Call Outbox during a call, press the **Call Outbox** key.



2. Press the **Up/Down** navigation key to highlight a call from the list of calls in your Call Outbox.
3. Press the **Enter** key to initiate a call to the highlighted caller.

#### **Note:**

This places the current call on hold, if it is not already on hold.

#### **OR**

Press the **Exit** soft key to return to the **Incall** screen.

### Related links

[Call Outbox](#) on page 102



# Chapter 11: Instant Messaging

You can use your IP Deskphone to send and receive an Instant Message (IM). You can access and respond to an IM while on a call. The blue LED (Feature Status Indicator) at the top left of the IP Deskphone lights accompanied by a beep when a new IM arrives.

## Related links

- [Configuring Instant Messaging](#) on page 105
- [Composing an Instant Message](#) on page 107
- [Instant Message Inbox/Outbox](#) on page 107
- [Viewing the content of an Instant Message](#) on page 109

---

## Configuring Instant Messaging

You can configure your IP Deskphone settings to manage an incoming IM.

- Enable or disable the automatic pop-up of a new IM.
- Enable or disable an audible alert on a new IM.

## Related links

- [Instant Messaging](#) on page 105
- [Instant Message automatic pop-ups](#) on page 105
- [Configuring IM audible alert](#) on page 106

---

## Instant Message automatic pop-ups

You can configure the IP Deskphone to automatically display an incoming new Instant Message (IM) as a pop-up. The IM pops up when the IP Deskphone is idle or while on a call. You can disable the IM pop-up feature.

### **Note:**

An IM pop-up does not occur if you are navigating the IM screens or navigating the menu structure in general. When this exception occurs, the IM goes directly to the IM Inbox.

When an IM pop-up appears you can do the following:

- Press the **View** soft key to view the complete details of the IM.

- Press the **Prev** soft key to skip to a previous IM (if applicable).
- Press the **Next** soft key to skip to the next IM (if applicable).
- Press the **Exit** soft key, the **Goodbye** fixed key, or **Quit** fixed key to exit the IM pop-up screen and return to the idle screen when you are not on a call or return to the In Call screen if the pop-up occurred during a call.

#### Related links

[Configuring Instant Messaging](#) on page 105

[Configuring Instant Messaging pop-ups](#) on page 106

## Configuring Instant Messaging pop-ups

You can configure Instant Messaging pop-ups.

#### To enable or disable automatic pop-up of a new IM:

1. Press the **Prefs** soft key, select **User Settings > IM Settings > IM Display: On/Off** from the menu.
2. Press the **Up/Down** navigation key to select the user (if multiple users are logged into the same deskphone).
3. Press the **Select** soft key
4. Press the **On/Off** soft key to toggle between enabling IM pop-ups or disabling IM pop-ups.

**OR**

Press the **Back** soft key to return to the previous menu.

#### Related links

[Instant Message automatic pop-ups](#) on page 105

---

## Configuring IM audible alert

You can configure the IP Deskphone to audibly alert you when a new IM arrives. The IP Deskphone audibly alerts you when the IP Deskphone is idle or while on a call. You can also choose to disable the audible alert of the IM feature.

#### To enable or disable the audible alerts of a new IM:

1. Press the **Prefs** soft key, select **User Settings**, select **IM Settings**, and then select **IM Audible Alert: On/Off** from the menu.
2. Press the **Select** soft key.
3. Press the **On/Off** soft key to toggle between enabling IM audible alerts or disabling IM audible alerts.

**OR**

Press the **Back** soft key to return to the previous menu.

#### Related links

[Configuring Instant Messaging](#) on page 105

---

## Composing an Instant Message

When you compose an IM, enter the address of the recipient and then enter the message. When you reply to an Instant Message, the IP Deskphone automatically enters the address. You can also send an IM directly from the Address Book.

### To compose and send an Instant Message:

1. Press the **Msgs** soft key, select **Instant Messaging**, and press the **New IM** soft key

**OR**

Access the list of IMs by pressing the **Expand** fixed key.



**OR**

To compose an IM from the Address Book, select an address and press the **Send IM** soft key.

2. Press the **abc/123** soft key to toggle between numeric and alphabetic input.
3. Use the dialpad to enter the address of the contact.
4. Press the **Next** soft key to continue.

**OR**

Press the **Back** soft key to return to the previous menu.

5. Use the dialpad to enter the content of the message.
6. Press the **Send context-sensitive** soft key to send the IM to the contact.

**OR**

Press the **Back context-sensitive** soft key to return to the previous menu without sending the new IM.

### Related links

[Instant Messaging](#) on page 105

---

## Instant Message Inbox/Outbox

The IM Inbox contains a list of all incoming and outgoing Instant Messages. You can filter the IM list to track a series of correspondence to a contact. The lit blue LED indicates the arrival of a new IM. An icon indicates the status of the IMs in your Instant Message Inbox/Outbox as follows:

Unread




---

*Table continues...*



### Related links

[Instant Messaging](#) on page 105

[Accessing Instant Messages](#) on page 108

---

## Accessing Instant Messages

You can access and view the contents of the Instant Message Inbox/Outbox.

### To access and view the contents of the Instant Message Inbox/Outbox:

1. Press the **Msgs** soft key, and then select **Instant Messaging** from the menu.

**OR**

Press the **Expand** fixed key.



2. Press the **Up/Down** navigation key to highlight an IM from the list of Instant Messages in your IM Inbox/Outbox.

**\* Note:**

When you want to view only IMs from a specific contact, press the **User** soft key to filter all IMs based on the IM that you highlight. The telephone display screen shows the list of all IMs from that contact.

3. Press the **View** soft key to view the details of the sender, followed by the message content.

**OR**

Press the **New IM** soft key to compose a new IM.

**OR**

Press the **Back** soft key to return to the idle screen.

### Related links

[Instant Message Inbox/Outbox](#) on page 107

---

## Viewing the content of an Instant Message

When you view the content of an Instant Message, you can do the following:

- reply to the Instant Message.
- initiate a call to the contact.
- delete the Instant Message.

### Related links

[Instant Messaging](#) on page 105

[Replying to an Instant Message](#) on page 109

[Initiating a call from an Instant Message](#) on page 109

[Deleting an Instant Message](#) on page 110

---

## Replying to an Instant Message

You can reply to an Instant Message.

### To reply to an Instant Message:

1. Press the **Reply** soft key to send an IM in response to the IM you are viewing.
2. Press the **abc/123** soft key to toggle between numeric and alphabetic input.
3. Enter the message you want to send as a reply.
4. Press the **Send** soft key to send the IM when it is complete.

**OR**

Press the **Back** soft key to return to the previous menu and not send the IM.

### Related links

[Viewing the content of an Instant Message](#) on page 109

---

## Initiating a call from an Instant Message

To initiate a call from the IM Inbox, press the **Expand** fixed key or press the **Msgs** soft key, and then select **Instant Messaging** from the menu.

### **Note:**

If your service provider requires that a Directory Number (DN) be used to initiate a call, you cannot initiate a call from an Instant Message.

### To initiate a call from an Instant Message:

1. Press the **Msgs** soft key, and then select **Instant Messaging** from the menu.

**OR**

Press the **Expand** fixed key.



2. Press the **Up/Down** navigation key to highlight an IM from the list of Instant Messages.
3. Press the **View** soft key to access the IM.
4. To initiate a call to the contact who sent the IM, press the **Call** soft key.

The IP Deskphone goes off-hook and initiates the call.

#### Related links

[Viewing the content of an Instant Message](#) on page 109

---

## Deleting an Instant Message

**To delete a single IM, all the IMs from one contact, or all the IMs in your IM Inbox:**

1. Press the **Msgs** soft key, and then select **Instant Messaging** from the menu.

**OR**

Press the **Expand** fixed key.

2. Press the **View** soft key.
3. Press the **Delete** soft key to clear all IMs from the IM Inbox/Outbox.

**OR**

Press the **Back** soft key to return to the previous screen.

#### Related links

[Viewing the content of an Instant Message](#) on page 109

# Chapter 12: Active calls and call features

This chapter provides information on active calls, and on call features available to the IP Deskphone user.

## Active calls

You can use the following features during an active call:

- Making a new call
- Placing a call on Hold
- Using 3-way calling
- Transferring a call

You can use the **Action** soft key to perform the following actions during an active call:

1. New Call—to begin a new call while other calls are on hold.
2. Release Call—to release (hang-up) the selected call.
3. Transfer Call—to transfer the call to another phone number or SIP address.

## FNE/FAC features

Access to certain Aura features is provided through dialing Feature Extension Numbers (FNEs) or Feature Access Codes (FACs).

To simplify the use of these features, you can configure speed dial keys for FNEs and FACs. This enables a feature to be easily accessed by pressing a speed dial key on the IP Deskphone instead of dialing an entire FNE or FAC code

## Related links

[Group Call Pickup](#) on page 112

[Making a new call](#) on page 112

[Ring Again Busy / Automatic Callback](#) on page 113

[Whisper Page](#) on page 114

[Call Waiting](#) on page 114

[Placing a call on Hold](#) on page 114

[Using 3-way calling](#) on page 118

[Ad hoc conferencing when connecting to the Call Server](#) on page 119

[Transferring a call](#) on page 120

[Using Park Call](#) on page 121

[Using the Friends feature](#) on page 122

[Feature keys](#) on page 125

[Using Call Forward](#) on page 134

[Configuring Do Not Disturb](#) on page 136

[Configuring a Presence state](#) on page 137

[Audio Codecs](#) on page 140

[PC Client softphone interworking with the IP Deskphone](#) on page 141

[Automatic remote software updates](#) on page 142

[Busy Lamp Field](#) on page 142

[Group Call Pickup](#) on page 112

---

## Group Call Pickup

With the Group Call Pickup feature, all members in a pickup group can answer a call that is ringing at another group member telephone. If more than one telephone is ringing, the system selects the extension that has been ringing the longest.

One or more pickup groups are created by your system administrator . A pickup group is a collection, or list of individual telephone extensions. A pickup group is the way to connect individual extensions together. A user extension can belong to only one pickup group.

To activate the Group Call Pickup feature on your IP Deskphone, enter the FAC or FNE provided to you by your system administrator.

### Related links

[Active calls and call features](#) on page 111

[Active calls and call features](#) on page 111

---

## Making a new call

You can initiate a new call during a current call. If you do not place the current call on hold first, the IP Deskphone automatically places the current call on hold when you initiate a new call. You can initiate a new call by using any of the following methods:

- Initiating a call using the active call context-sensitive soft key menu.
- Initiating a call from the Address Book.
- Initiating a call from the Call Inbox.
- Initiating a call from the Call Outbox.

### Related links

[Active calls and call features](#) on page 111

[Initiating a call using the active call soft key menu](#) on page 113



---

## Initiating a call using the active call soft key menu

You can initiate a call using the active call soft key menu.

### To initiate a call using the active call soft key menu:

1. Press the **Conf** soft key while on a call.

**OR**

While on a call, press the **More...** soft key, and then the **NewCall** soft key.

The IP Deskphone produces a dial tone.

2. Use the dial pad to dial the number or SIP address.

 **Note:**

This places the current call on hold, if it is not already on hold, and you can continue to initiate the call as normally.

**OR**

Press the **Back** soft key to return to the in-call screen.

### Related links

[Making a new call](#) on page 112

---

## Ring Again Busy / Automatic Callback

Using the Ring Again Busy/Automatic Callback (ACB) feature, internal users who place a call to a busy or an unanswered internal telephone can be called back when the called telephone becomes available.

Upon placing a call and hearing a busy signal, activate the Automatic Callback feature and disconnect the call. The system monitors the called party. When the called party becomes available to receive the call, the system automatically initiates the Automatic Callback call. You hear priority ringing. Lift the handset, and the called party receives the same ringing that the system provided on the originating call.

### To activate Ring Again Busy / Automatic Callback:

1. If you hear a busy tone after placing a call to an internal telephone, terminate the call.
2. Dial the Ring Again Busy / Automatic Callback FAC/FNE provided to you by your administrator.

You hear a confirmation tone.

3. When the called number is free, your IP Deskphone rings. Answer the call and you are connected to your called party.

## Related links

[Active calls and call features](#) on page 111

---

## Whisper Page

Use the Whisper Page feature to send a page to a contact while they are on an active call. With you use the Whisper Paging feature, only the person on the paged extension can hear the page. Other parties on the call cannot hear the page, and you cannot hear anyone on the call. If the paged user has a display telephone, the paged user can see who makes the whisper page.

### To create a Whisper page

1. Dial the Whisper Page FAC provided to you by your system administrator.
2. Dial the number to which you want to send the Whisper Page.

All parties, including you, hear the Whisper Page tone, but only the party to whom the page was sent hears the page itself. You cannot hear either of the parties in the active call.

## Related links

[Active calls and call features](#) on page 111

---

## Call Waiting

When you are on an active call and you receive an incoming call, you are notified of the incoming call by a message on the telephone display screen and a notifying beep. Answering the new call places the active call on hold. You can also redirect the new call, transfer the new call, or ignore the new call.

## Related links

[Active calls and call features](#) on page 111

---

## Placing a call on Hold

Use the Hold feature when you are talking to one contact and want to perform another action, such as answer a new incoming call, transfer a call, or initiate a new call. You can have a number of calls on hold at the same time.

### To place a call on hold:

1. Press the **Hold** fixed key.



The LCD on hold icon flashes beside the line on hold.

**To retrieve a call on hold:**

Press the **Line** feature key beside the flashing LCD indicator.

**OR**

Press the **Hold** fixed key.

**To release a call on hold:**

**!** **Important:**

You must retrieve a call from hold before you can end it.

1. Retrieve the call on hold:
  - Press the **Line** feature key beside the flashing LCD indicator.

**OR**

  - Press the **Hold** fixed key.
2. Press the **Goodbye** fixed key.

**Related links**

[Active calls and call features](#) on page 111

[Multiple calls On Hold](#) on page 115

## Multiple calls On Hold

When you have more than one call on hold, use the navigation key to highlight a call on the telephone display screen. You can perform an action with that call by using the soft keys on the In-call menu list. The soft keys displayed vary, depending on the type of call that is currently selected.

When you highlight a call that is not active, you can retrieve the call from on hold and make it active by pressing the **Activate** soft key. You can also join the call with the active call to create a 3-way calling session. .

### Multiple calls In-call mode

When the IP Deskphone has multiple calls connected at the same time, you can access the menu items listed in the following table.


**\* Note:**

The **Join** soft key appears when there are multiple calls on the IP Deskphone that can be joined for a conference call or 3-way calling.

**Table 14: Context-sensitive soft keys for the multiple calls In-call display screen**

Soft key label	Function
Join	Press the <b>Join</b> soft key to join the eligible calls.

*Table continues...*

Soft key label	Function
<b>New Call</b>	Press <b>NewCall</b> soft key to obtain a dial tone to place another call. The <b>NewCall</b> soft key is used to make a conference call. This key behaves like the <b>Conf</b> soft key.
<b>Audio/Activate</b>	<p>Press the <b>Audio</b> soft key to change the audio codec and monitor audio quality.</p> <p>The <b>Activate</b> soft key appears when the highlighted call is not the selected call.</p> <p>Press the <b>Activate</b> soft key to place the current call on hold and activate the call you want to connect to.</p> <p>This soft key is also used to retrieve calls parked against the user.</p> <p> <b>Note:</b></p> <p>The <b>Activate</b> soft key never appears at the same time as the <b>Audio</b> context-sensitive soft key</p>
<b>More...</b>	<p>Press the <b>More...</b> soft key to select a new menu list of soft keys.</p> <p>When you press the <b>More...</b> soft key, a different selection of soft keys appears.</p> <ul style="list-style-type: none"> <li>• If you press the <b>More...</b> soft key once from the first menu list, you access the following soft keys: <b>[Trnsfer] [RlsCall] [Join] [More...]</b></li> <li>• If you press the <b>More...</b> soft key from the first menu list twice, you access the following context-sensitive soft keys: <b>[Conf] [Audio] [New Call] [More...]</b></li> <li>• If you press the <b>More...</b> soft key from the first menu list three times, you return to the first menu list with the following soft keys. <b>[Prefs] [Blank] [Blank] [More...]</b></li> </ul>
When you press the <b>More....</b> soft key for the first time, the following context-sensitive soft keys appear on the menu list.	
<b>Trnsfer</b>	Press the <b>Trnsfer</b> soft key to transfer the current call.
<b>RlsCall</b>	Press the <b>RlsCall</b> soft key to release or hang up the highlighted call.
<b>Conf</b>	Press the <b>Conf</b> soft key to place another call, which can be used for a conference call. This context-sensitive soft key has the same behavior as the <b>NewCall</b> soft key.
<b>More...</b>	<p>Press the <b>More...</b> soft key to select a new menu list of soft keys.</p> <p>The next available menu list contains the following soft keys: <b>[Retrve] [Conf] [Prefs] [more...]</b></p>
When you press the <b>More...</b> soft key for the second time, the following soft keys appear on the menu list.	
<b>Prefs</b>	<p>Press the <b>Prefs</b> soft key to display the Preferences menu.</p> <p>The menu items include the following:</p> <ol style="list-style-type: none"> <li>1. <b>Display</b>—use to adjust the display settings of the LCD screen.</li> </ol>

*Table continues...*

Soft key label	Function
	<p>2. <b>Audio</b>—use to adjust tones and volume settings.</p> <p>3. <b>Feature Options</b>—use to configure the following:</p> <ul style="list-style-type: none"> <li>• Feature keys</li> <li>• Call Ignore Action</li> <li>• Call Decline Reason</li> <li>• Call Subjects</li> <li>• Call Fwd Notification</li> <li>• Missed Call Notification</li> <li>• Answer Mode Settings — appears when the Auto Answer Mode is enabled on the IP Deskphone.</li> </ul> <p>4. <b>Language</b>—use to change the interface language.</p> <p>5. <b>Misc Options</b>—use to access the following options:</p> <ul style="list-style-type: none"> <li>• Alpha Dialing</li> <li>• Search Method</li> <li>• Incoming Privacy</li> <li>• Outgoing Privacy</li> <li>• # Ends Dialing</li> <li>• Hold Mode: Private</li> <li>• Time</li> </ul> <p>6. <b>Network</b>—use to access the following:</p> <ul style="list-style-type: none"> <li>• Server Settings</li> <li>• Device Settings</li> <li>• Diagnostics</li> <li>• Disable screensaver</li> <li>• Licensing</li> <li>• Lock</li> </ul> <p>7. <b>User Settings</b>—use to modify the following:</p> <ul style="list-style-type: none"> <li>• Call Settings</li> <li>• IM Settings</li> <li>• Voice Mail Settings</li> <li>• Change Location</li> </ul>
<blank>	
<blank>	

*Table continues...*

Soft key label	Function
More...	Press the <b>More...</b> soft key to return to the first menu list of soft keys. The next available menu list contains the following soft keys: <b>[Join] [NewCall] [Audio] [more...]</b>

### To access a call on hold when multiple calls are on hold:

1. Press the **Up/Down** navigation key to highlight a call on hold.
2. Press the **Line** feature key beside the flashing LCD indicator.

**OR**

Press the **Hold** fixed key to retrieve a call on hold.

### To make a call on hold the active call:

1. Press the **Up/Down** navigation key to highlight a call on hold.
2. Press the **Activate** soft key to make the highlighted call on hold the active call.

This removes the call from on hold and automatically places the previous call on hold.

### To release a call on hold:

#### **Important:**

You must make a held call the active call before you can release it.

1. Press the **Up/Down** navigation key to highlight a call on hold.
2. Press the **Activate** soft key to make the highlighted call on hold the active call.

This removes the call from on hold and automatically places the previous call on hold.

3. Press the **RlsCall** soft key to release or hang up the highlighted call.

### Related links

[Placing a call on Hold](#) on page 114

---

## Using 3-way calling

When you have more than one call and you want to join the incoming calls into one call, you can use 3-way calling or create a conference call.

#### **Note:**

Your system administrator or service provider must enable 3-way calling and conference calls for your IP Deskphone. Contact your service provider or system administrator to determine if this feature is available.

The 3-way Call feature joins two calls on your IP Deskphone into one 3-way call. You and the other two callers can speak together. When you join more than two calls into one call, you must use the

conference call feature. Your IP Deskphone manages the 3-way call, and the server manages a conference call. .

### To activate the 3-way Call feature:

Press the **Join** soft key with either call, and then select **3-way Call** from the menu.

The IP Deskphone joins the two calls and creates a new call that appears on the LCD screen as 3-way Call].

#### \* Note:

- If you receive a new call during a 3-way call, you can answer the new call as usual. The IP Deskphone automatically puts the 3-way call on hold. If you want to join the new caller to a 3-way call, you must initiate a conference call with the server and join all callers to the conference call.
- If the host of a 3-way call presses the **Hold** button, all callers in the 3-way call are put on hold.
- If the host of a 3-way call presses the **Goodbye** fixed key or selects **Release Call** from the **Action** menu, all calls in the 3-way call are terminated.

#### Related links

[Active calls and call features](#) on page 111

---

## Ad hoc conferencing when connecting to the Call Server

This feature allows you to make ad hoc conference calls when you connect to the Call Server.

#### \* Note:

Your system administrator must enable ad hoc conferencing before you connect to the Call Server.

### To create an ad hoc conference with a third party

1. Place the active call on hold.
2. Press the **NewCall** soft key or press the **Conf** soft key.
3. Dial the **Conference on Answer** FNE provided to you by your system administrator.  
Communication Manager confirmation tone is heard.
4. Enter the telephone number of the contact to conference.  
A confirmation tone is heard.
5. When the call is answered, press the line key for the call on hold.  
The conference is established.

**\* Note:**

Ad-hoc conference calls are only available to the primary account.

**Related links**

[Active calls and call features](#) on page 111

---

## Transferring a call

**\* Note:**

- When more than one call is on hold, the call you want to transfer must be the active call.
- The IP Deskphone does not automatically place the call you want to transfer on hold. To prevent the caller from hearing the transfer process, place the caller on hold and then complete the transfer process.

**To transfer a call to another telephone:**

1. Press the **Trnsfer** soft key while on an active call to access the **Trnsfer** menu.
2. Press the **abc/123** soft key to toggle between numeric and alphabetic input.
3. Enter the phone number or SIP address to which you are transferring the call.

**OR**

Select a contact from the Address Book, Call Inbox, or Call Outbox by pressing the corresponding fixed key.

**OR**

Highlight a contact from the list and then press the **Select** soft key.

4. Choose one of the following:
  - Press the **Transfr** soft key to connect the calling party.
  - To erase the address you enter, press the **Clear** soft key.
  - To return to the previous screen, press the **Back** soft key.

If you pressed the **Transfr** soft key, the IP Deskphone prompts you with the following question:

Consult with party?

5. • Press the **Yes** soft key to consult with the contact to which you are transferring the call before completing the transfer.

**OR**

- Press the **No** soft key to transfer the call without consulting the contact to whom you want to transfer the call.

A **Transferring...** message is displayed.

Press the **Exit** soft key to close the **Transferring...** dialog.



Your IP Deskphone then displays any local calls, including the transferred call, until `Transfer successful` or `Transfer failed` is displayed, depending on the transfer results.

**OR**

- Press the **Back** soft key to return to the previous screen.

**To transfer an active call to Voice Mail:**

1. Press the **Trnsfer** soft key while on a call to access the Transfer menu.
2. Press the **abc/123** soft key to toggle between numeric and alphabetic input and enter the Voice Mail ID, extension, or external number by using the dialpad.
3. Press the **Trnsfer** soft key again.
4. When `Consult with party?` is prompted, choose one of the following:
  - Press the **To VM** soft key to connect the calling party to Voice Mail.
  - To return to the previous screen, press the **Back** soft key.

**\* Note:**

- The Transfer to Voice Mail feature is not available for all call servers. Contact your system administrator or service provider to determine if this feature is available to you.
- The Transfer to Voice Mail feature during a conference call is dependent on the call server and is not allowed. If the Secure Digits feature is enabled, and you connect to Voice Mail during an active call, the screen displays only the last pressed key , and the remaining digits appear as “\*”.

You can press **Hide** or **Unhide** to hide or display the pressed keys.

**\* Note:**

The Transfer to Voice Mail feature is available only when configured by your system administrator.

**Related links**

[Active calls and call features](#) on page 111

## Using Park Call

You can use the Park Call feature to temporarily park a call to the call server or to a specific user. You or another user can retrieve the parked call from another phone. Using Park Call does not tie up a line, since it is held on the call server.

**To park a call to the server during a call:**

1. Press the **NewCal** soft key.
2. Dial the FNE of Call Park and press the **Send** soft key.

**\* Note:**

The FNE number is provided by your system administrator.

**To retrieve a parked call to the same phone:**

1. Dial the FNE of Call Retrieve and press the **Send** soft key.
2. Press the **#** key.

**To retrieve a parked call to a different phone:**

1. Dial the FNE of Call Retrieve and press the **Send** soft key.
2. Enter the extension number the call is parked on.

**Call Park and Speed Dial keys**

You can program speed dial keys for Call Park and Call Retrieve.

Use **Prefs > Feature Options > Feature Keys > Speed Dial** to program Call Park and Call Retrieve buttons with the appropriate FNE codes.

**To park a call using Speed Dial**

1. While on the call, press the **Trnsfr** soft key.
2. Press the **Call Park** speed dial button.
3. Press the **No** when prompted with `Consult with Party?`.

The call is parked and your IP Deskphone phone returns to idle.

**To retrieve a parked call using Speed Dial**

1. Press the **Call Retrieve** speed dial button.
2. Press **#** if retrieving the call on the same phone the call was parked from. Otherwise, enter the extension number on which the call is parked .

The call is retrieved and connected.

**Related links**

[Active calls and call features](#) on page 111

---

## Using the Friends feature

You can designate a contact you have frequent interaction with as a friend. Access your friends list in the Address Book to:

- Check the presence status of a friend.
- Initiate a call to a friend.
- Send an IM to a friend.
- Edit the information about a friend.

**Related links**

[Active calls and call features](#) on page 111

[Accessing your Friends list](#) on page 123

[Editing information of a friend](#) on page 124

---

## Accessing your Friends list

### To check the online status of a friend on your Friends list:

1. Press the **Directory** fixed key.
2. Press the **Filter** soft key, and select **Friends** from the menu.
3. Press the **Up/Down** navigation key to highlight the desired friend and press the **Select** soft key.
4. Press the **Status** soft key to view the current presence status of the friend.
5. Press the **Exit** soft key to return to the idle screen.

### To initiate a call to a friend on the Friends list:

1. Press the **Directory** fixed key.
2. Press the **Filter** soft key, and select **Friends** from the menu.
3. Press the **Up/Down** navigation key to highlight the desired friend and press the **Select** soft key.
4. Press the **Status** soft key to view the current presence status of the friend.
5. Press the **Call** soft key to initiate a call to the friend.

The IP Deskphone uses the SIP address or phone number from your personal Address Book to make the call.

### To send an IM to a friend on the Friends list:

1. Press the **Directory** fixed key.
2. Press the **Filter** soft key, and select **Friends** from the menu.
3. Press the **Up/Down** navigation key to highlight the desired friend and press the **Select** soft key.
4. Press the **Status** soft key to view the current presence status of the friend.
5. Press the **SendIM** soft key to send an IM to the friend.

The IP Deskphone uses the SIP address for the contact from your personal Address Book.

6. Use the dialpad to enter the text of the message.
7. Press the **abc/123** soft key to toggle between numeric and alphabetic input.
8. Press the **Send** soft key to send the IM.

#### OR

Press the **Back** soft key to return to the previous menu.

### Related links

[Using the Friends feature](#) on page 122

## Editing information of a friend

You can edit information of a friend on the Friends list.

### To edit information of a friend on your Friends list:

1. Press the **Directory** fixed key.
2. Press the **Filter** soft key, and select **Friends** from the menu.
3. Press the **Up/Down** navigation key to highlight the desired friend and press the **Edit** soft key.
4. Press the **abc/123** context-sensitive soft key to toggle between alphabetic and numeric characters.
5. Use the dialpad to enter a new name for the contact.
6. Press the **Next** soft key to continue.

**OR**

Press the **Back** soft key to return to the previous menu.

**OR**

To remove a contact from the Friends list, press the **Delete** soft key. This completely removes the contact from your personal Address Book.

7. Use the dialpad to enter the new address for the contact.
8. Press the **Next** soft key to complete the process.

**OR**

Press the **Back** soft key to return to the previous menu.

9. If you want to add the contact to a group, press the **Yes** soft key, select the group and press the **Select** context-sensitive soft key to add contact to the group.

**OR**

Press the **No** soft key to return to the previous menu without adding contact to a group.

**OR**

Press the **Back** soft key to return to the previous menu.

10. Press the **Ok** contact-sensitive key to return to the Friends list. Press the **Ok** contact-sensitive key to return to the Friends list.

### To delete a contact from your Friends list:

1. Press the **Directory** fixed key.
2. Press the **Filter** soft key, and select **Friends** from the menu.
3. Press the **Up/Down** navigation key to highlight the desired friend and press the **Edit** soft key.
4. Press the **Delete** key. This completely removes the contact from your personal Address Book.

5. Press the **Ok** soft key to continue.

**OR**

Press the **Back** soft key to return to the previous menu.

#### Related links

[Using the Friends feature](#) on page 122

---

## Feature keys

Use the Feature key option to configure the feature keys on IP Deskphone and the Expansion Module for Avaya 1100 Series IP Deskphones.

Programmed keys are stored in the user profile. Each user can maintain a list of programmed feature keys. You can designate a feature key to act as a short cut for any of the following features:

- Speed Dial
- Call Forward
- Do Not Disturb
- Send IM
- Presence

The IP Deskphone designates the feature key on the bottom right of the four feature keys as Feature Key 1 and reserves it as the line key for the IP Deskphone.

You can program the feature keys one at a time, or you can automatically program empty feature keys from your Friends list or Address Book.

Feature keys can also be programmed on the Expansion Modules.

#### Related links

[Active calls and call features](#) on page 111

[Feature key programming](#) on page 125

[Remove a programmed feature key](#) on page 130

[Feature key autoprogramming](#) on page 131

---

## Feature key programming

You can program feature keys.

#### To access the Program Key screen:

Press the **Prefs** soft key, select **Feature Options**, and select **Feature Keys** from the menu.

The **Program Key** screen opens .

The **Program Key** screen provides the following soft keys:

- **View**— to access the feature key detail screen.
- **Edit** —to edit the setting or modification of the selected programmable key.
- **Bulk**—to access the autoprogramming and auto removal feature.
- **Back**—to return to the previous screen.

**To view feature key details:**

1. To select a feature key to view, do one of the following:
  - Press the **Up/Down** navigation key to highlight the feature key to view and press the **View** context-sensitive soft key.
  - Press the **Feature** key that you want to view and press the **View** context-sensitive soft key.
  - Use the dialpad to select the **Feature** key that you want to view and press the **View** soft key.
2. Press the **Back** soft key to return to the previous screen.

The **Program Key** screen displays the following:

- Key—programmed feature key number
- Label—label used for the feature key
- Service—services programmed to the feature key, such as:
  - Speed Dial
  - Call Forward
  - Do Not Disturb
  - Send IM
  - Presence
- User—current user to whom the programmed feature key is associated
- Address—SIP address for the feature key when programmed for Speed Dial, Call Forward, and Send IM.

 **Note:**

If you try to view a feature key that is not programmed, the IP Deskphone displays the message:

Program Key Not Available (Key is empty).

**To edit a feature key:**

1. To select a feature key to edit, do one of the following:
  - Press the **Up/Down** navigation key to scroll through the feature keys to highlight the one you want to edit and then press the **Edit** context-sensitive soft key.
  - Press the **Feature** key that you want to edit and then press the **Edit** soft key.

- Use the dialpad to select the **Feature** key that you want to view and then press the **Edit** soft key.

The **Program Key** screen opens.

2. Press the **Back** soft key to return to the previous screen.

### To modify a feature key:

1. Press the **Modify** soft key.
2. Press the **Up/Down** navigation key to highlight one of the following feature key services:
  - Speed Dial
  - Call Forward
  - Do Not Disturb
  - Send IM
  - Presence
3. Press the **Select** soft key to choose a service.

#### OR

Press the **Back** soft key to return to the previous menu.

4. Press the **abc/123** soft key to toggle between numeric and alphabetic input.
5. Use the dialpad to enter the label for the feature key.
6. Press the **Next** soft key to continue. Continue to input information based on the following services:
  - Speed dial.
  - Call Forward.
  - Do Not Disturb.
  - Send IM.
  - Presence.

#### OR

Press the **Back** soft key to return to the previous menu.

### To program a Speed Dial feature key:

To program a Speed Dial feature key, beginning from [Step 6 in the procedure “To modify a feature key”](#) on page 127:

1. Press the **Select** soft key.
2. Select **Speed Dial**.
3. Press the **Select** soft key.
4. Use the dial pad to enter a key label.
5. Press the **Next** soft key to continue.
6. Use the dial pad to enter an address.
7. Press the **Next** soft key to continue.

8. Use the dial pad to enter a Call Subject associated with the Speed Dial contact. You can leave this blank if you do not want to include a Call Subject.
9. Press the **Ok** soft key to confirm the entry and move to the next step.

**OR**

Press the **Cancel** soft key to return to the previous step.

10. Press the **Yes** soft key to activate auto-retrieve of held call on hang up of speed dial.

**OR**

Press the **No** soft key to return to the previous step.

### **To program a Call Forward feature key:**

To program a Call Forward feature key, beginning from [Step 6 in the procedure “To modify a feature key”](#) on page 127:

1. Press the **Select** soft key.
2. Select **Call Forward**
3. Use the dial pad to enter a key label.
4. Press the **Next** soft key to continue.
5. Select a User.
6. Press the **Select** soft key.
7. Use the dial pad to enter the address.
8. Press the **Finish** soft key to confirm the entry and complete the procedure.

**OR**

Press the **Clear** soft key to erase the entry.

**OR**

Press the **Back** soft key to return to the previous menu.

### **To program a Do Not Disturb feature key:**

To program a Do Not Disturb feature key, beginning from [Step 6 in the procedure “To modify a feature key”](#) on page 127:

1. Press the **Select** soft key.
2. Select **Do not disturb**.
3. Press the **Select** soft key.
4. Use the dial pad to enter a key label.
5. Select a User.
6. Press the **Select** soft key.
7. Press the **Finish** soft key to confirm the entry and complete the procedure.

**OR**

Press the **Back** soft key to return to the previous menu.



### To program a Send IM feature key:

To program a Send IM feature key, beginning from [Step 6 in the procedure “To modify a feature key”](#) on page 127:

1. Press the **Select** soft key.
2. Select **Send IM**.
3. Press the **Select** soft key.
4. Use the dial pad to enter a key label.
5. Press the **Next** soft key.
6. Use the dial pad to enter an address.
7. Press the **Finish** soft key to continue.

### To program a Presence feature key for Presence Model v6:

Beginning from [Step 6 in the procedure “To modify a feature key”](#) on page 127:

1. Press the **Select** soft key.
2. Press the **Up/Down** navigation key to highlight one of the following:
  - Connected
  - Unavailable
3. Press the **Select** soft key to select **Presence**.

#### OR

Press the **Back** soft key to return to the previous step.

4. You can choose a more detailed message as follows for other users to see or you can select **None** if you do not want to give additional information.
5. You can choose a status from the following:

Appointment	Permanent absence
Away	Playing
Breakfast	Presentation
Busy	Shopping
Dinner	Sleeping
Holiday	Spectator
In transit	Steering
Looking for work	Travel
Lunch	TV
Meal	Vacation
Meeting	Working
On the phone	Worship
Performance	Unknown

**\* Note:**

You can create your own Presence message to appear on screen, which become available when you program a feature key as a shortcut.

6. Press the **Finish** soft key to select the **Presence** detail and finish the procedure.

**OR**

Press the **Back** soft key to return to the previous step.

**To program a Presence feature key for Presence Model v7:**

Beginning from [Step 6 in the procedure “To modify a feature key”](#) on page 127:

1. Select a User.
2. Press the **Select** soft key.
3. Press the **Select** soft key to select **Presence**.

You can choose a status from the following:

- Available
- Away
- Busy
- Do not disturb
- Out Of Office
- Offline

**OR**

Press the **Back** soft key to return to the previous step.

4. Press the **Finish** soft key to select the **Presence** detail and finish the procedure.

**OR**

Press the **Back** soft key to return to the previous step.

**Related links**

[Feature keys](#) on page 125

---

## Remove a programmed feature key

You can remove a feature key by using one of the following methods:

- Edit context-sensitive soft keys.
- Bulk context-sensitive soft keys.

**To remove a feature key using the Edit soft key:**

1. Press the **Prefs** soft key, select **Feature Options**, and select **Feature Keys** from the menu.

The **Program Key** screen opens as shown in [Feature keys](#) on page 125.

2. To select a feature key to remove, do one of the following:
  - Press the **Up/Down** navigation key to scroll through the feature keys to highlight one to remove and press the **Edit** soft key.
  - Press the feature key that you want to remove and then press the **Edit** soft key.
  - Use the dialpad to select the **Feature** key that you want to view and then press the **Edit** soft key.

The **Program Key** screen opens.

3. Press the **Back** soft key to return to the previous screen.
4. Press the **Remove** soft key.

The IP Deskphone displays `Confirm Remove key?`

5. Press the **Yes** soft key to confirm the removal of the feature key.

OR

Press the **No** soft key to return to the previous screen without removing the feature key.

#### Related links

[Feature keys](#) on page 125

---

## Feature key autoprogramming

Feature key autoprogramming provides the user with the ability to cause the IP Deskphone to detect all unused programmable keys, and to automatically fill them as Speed Dial keys, Send IM keys, or Call Forwarding keys using the user Friends list or the user Address Book. The feature key autoprogramming also provides the user with the ability to remove all programmed feature keys from the IP Deskphone.

Autoprogramming does not overwrite feature keys already programmed and when the IP Deskphone detects if a feature key is already configured with Speed Dial, Send IM, or Call Forward for contact, it does not create a new instance.

#### **Note:**

The autoprogramming feature options are dependent on your service provider and IP Deskphone configuration. If you attempt to use the autoprogram feature (**Bulk** soft key) for a feature that is not available to you, the IP Deskphone displays the message: `This feature is disabled. Contact your provider.`

#### **To autoprogram feature keys:**

1. Press the **Prefs** soft key, select **Feature Options**, and select **Feature Keys** from the menu.  
The **Program Key** screen opens.
2. Press the **Bulk** soft key.

OR

Press the **Back** soft key to return to the previous step.

3. Press the **Select** context-sensitive soft key to select menu item **1. Feature key creation**.
4. Press the **Up/Down** navigation key to highlight one of the following services that you want to autoprogram:
  - 1. Speed Dial
  - 2. Send IM
  - 3. Call Forward
5. Press the **Select** soft key to autoprogram the feature keys with the selected service.

**OR**

Press the **Back** soft key to return to the previous step.

### **To remove all programmed feature keys by using the Bulk soft key:**

To remove all programmed feature keys, or an individual programmed feature key, by using the Bulk context-sensitive soft key:

1. Press the **Prefs** soft key, select **Feature Options**, and select **Feature Keys** from the menu.
2. Press the **Bulk** soft key.
3. Press the Up/Down navigation key to highlight the **2. Feature key removal** menu item and press the **Select** soft key.
4. Press the **All** soft key to remove all the programmed feature keys.
5. Press the **Yes** soft key to confirm the removal of all the feature keys.

**OR**

Press the **No** soft key to return to the previous screen without removing the feature keys.

6. To select a single feature key to remove, do one of the following:
  - Press the Up/Down navigation key to scroll through the feature keys and highlight the feature key to remove and press the **Remove** soft key.
  - Press the **Feature** key that you want to remove and press the **Remove** soft key.
  - Use the dialpad to select the **Feature** key that you want to view and press the **Remove** soft key.

**OR**

Press the **Back** soft key to return to the previous menu.

### **Remove individual programmed feature keys by using the Bulk soft key:**

1. Press the **Prefs** soft key, select **Feature Options**, and select **Feature Keys** from the menu.
2. Press the **Bulk** soft key.
3. Press the Up/Down navigation key to highlight the **2. Feature key removal** menu item and press the **Select** soft key.

The **Program Key** screen opens listing all the feature keys.

4. To select a single feature key to remove, do one of the following:
  - Press the Up/Down navigation key to scroll through the feature keys to highlight one and press the **Remove** context-sensitive soft key.
  - Press the **Feature** key that you want to remove and then press the **Remove** context-sensitive soft key.
  - Use the dialpad to select the **Feature** key that you want to view and then press the **Remove** soft key.

**OR**

Press the **Back** soft key to return to the previous menu

5. Press the **Yes** soft key to confirm the removal of the feature key.

**OR**

Press the **No** soft key to return to the previous screen without removing the feature keys.

### Related links

[Feature keys](#) on page 125

[Creating a feature key using the Copy key](#) on page 133

## Creating a feature key using the Copy key

You can create a feature key for Speed Dial, Call Forward, or Send IM by pressing the **Copy** fixed key when you are viewing any of the following:

- a highlighted entry in an Address Book list
- a highlighted entry of your Call Inbox or Call Outbox

### To designate a feature key by using the Copy key:

1. Open your Address Book, Call Inbox, or Call Outbox, highlight the entry you want to use for the feature key, and then press the **Copy** key.
2. Press the **Up/Down** navigation key to highlight Speed Dial, Call Forward, or Send IM from the menu.

#### **Note:**

Presence and Do Not Disturb are not programmable by using the **Copy** key.

3. Press the **Select** soft key.
4. Press the **Up/Down** navigation key to highlight the feature key to which to copy the information to and press **Set**.

**OR**

Press the **Feature** key that you want to use for the service selected.

5. Use the dialpad to enter the label for the feature key.
6. Press the **Next** soft key to continue. Continue to input information based on the selected service:
  - Speed Dial
  - Call Forward

- Send IM
- Presence

See [Feature key programming](#) on page 125.

**OR**

Press the **Back** soft key to return to the previous menu.

**Related links**

[Feature key autoprogramming](#) on page 131

---

## Using Call Forward

Use the Call Forward feature to direct incoming calls to an alternate destination. You can continue to make calls from the IP Deskphone but all incoming calls are redirected to the new destination.

When you forward a call to another IP Deskphone, the IP Deskphone that receives the call displays the name and SIP address (if present) of the caller, the name and SIP address (if present) of the original called party, and any subject message included with the call. This ensures that the user who receives the forwarded call knows that the call is forwarded from you, who the call is from, and any subject message that is included.

**\* Note:**

Not all service providers display forwarded calls as described. Contact your system administrator or service provider for more information about Call Forward.

When the address or subject line is long, you can scroll by using the left and right navigation keys.

### Call Forward reminder signal

When you forward your calls to another user or IP Deskphone, you have the option to program the IP Deskphone to remind you that incoming calls can be forwarded. This notification is an audible signal you hear when you go off hook and a change to the ring pattern when a call is incoming.

To activate or deactivate this notification:

1. Press the **Prefs** soft key, select **Feature Options**, and select **Call Fwd Notification** from the menu.
2. Press the **On** soft key to activate Call Forward Notification

**OR**

If the Call Forward Notification is activated, press the **Off** soft key to deactivate the feature.

**\* Note:**

If the IP Deskphone is ringing or is in Do Not Disturb mode, you cannot forward the call.

## Activate Call Forward

To forward your calls or change the number where calls are forwarded:

1. Press the **CallFwd** soft key.
2. Use the dialpad to enter the phone number or SIP address where you want to forward your calls.
3. Press the **Forwrd** soft key to accept the number and return to the Services Menu.

**OR**

Press the **Clear** soft key to clear the input line.

**OR**

Press the **Back** soft key to cancel the input and return to the **Services** menu.

## Deactivate Call Forward

To deactivate Call Forward:

Press the **Disable** soft key to deactivate Call Forward and return to the **Services** menu.

**OR**

Press the **Back** soft key to cancel deactivating the Call Forward and return to the **Services** menu.

## Call Forward Unconditional

Call Forward unconditional is used to immediately redirect your calls.

To configure the Call Forward Unconditional number to which calls are to be forwarded, enter the Communication Manager FNE provided by your administrator. To disable Call Forward Unconditional , enter the Communication Manager FNE provided by your administrator

## Call Forward Busy and Call Forward No Answer

Use Call Forward Busy to redirect incoming calls to another destination when you are busy on all of your call appearances; the system immediately forwards the call. The system does not cause the telephone to ring before the system forwards the call to another destination.

Use Call Forward No Answer to redirect incoming calls to another destination when you do not answer the call within the allowed time interval. If you do not answer a call, the telephone rings for the allowed time interval. At the end of the interval, the system forwards the call to another destination.

To configure the Call Forward Busy number to which calls are to be forwarded, enter the Communication Manager FNE provided by your administrator. To disable Call Forward Busy , enter the Communication Manager FNE provided by your administrator

## Extended Call Forwarding

Extended Call Forwarding allows you to configure the telephone number to which all calls or busy/ unanswered calls to a specific phone are to be forwarded.

### To enable Extended Call Forwarding for Phone 1:

1. From Phone 2, dial the activation FAC and the extension of Phone 1, followed by #.
2. Enter the security code for Phone 1, followed by #.

3. Enter the forward-to extension (Phone 3).

#### **To disable Extended Call Forwarding for Phone 1:**

1. From another phone, dial the deactivation FAC and the extension of Phone 1, followed by #.
2. Enter the security code for Phone 1, followed by #.
3. Enter the forward-to extension (Phone 3).

#### **Remote Send All Calls**

The Remote Send All Calls feature allows a telephone user to activate or deactivate Send All Calls for a specified extension from a telephone whose Class of Restriction includes console permissions.

#### **To enable Remote Send All Calls:**

1. Dial the Activation FAC.
2. Enter the extension of the target phone followed by .
3. Enter the Station Security Code followed by #.

#### **To disable Remote Send All Calls:**

1. Dial the Deactivation FAC.
2. Enter the extension of the target phone followed by .
3. Enter the Station Security Code followed by #.

#### **Related links**

[Active calls and call features](#) on page 111

---

## **Configuring Do Not Disturb**

Use Do Not Disturb to automatically block all incoming calls. When you activate this feature, the calling party receives a busy signal.

#### **To enable Do Not Disturb**

1. Press the **DND** soft key on the idle display (press the **More...** context-sensitive soft key until DND appears).
2. Press the **Enable** soft key to configure the IP Deskphone to Do Not Disturb.

**OR**

Press the **Back** soft key to return to the previous menu.

3. Press the **Ok** soft key to return to the **Services** menu.

#### **To disable Do Not Disturb**

1. Press the **Disable** soft key to configure Do Not Disturb.

**OR**

Press the **Back** soft key to return to the previous menu.



2. Press the **Ok** soft key to return to the **Services** menu.

### Related links

[Active calls and call features](#) on page 111

---

## Configuring a Presence state

The Presence feature enables other users to see and monitor your availability state. There are two different models (versions) which Presence supports: the older model v6 and the newer model v7. Which model is used depends on a configuration parameter. Contact your administrator to find out which model is used on your system.

Model v6 has only one mode from which you can select from a list of states. However, in model v6 there are several states which are published automatically when corresponding events occur. For example, the state “On the Phone” is published in case the user makes a call and their current phone state is “Connected”. State “On hook” is published when the call is finished and only if phone state is “Connected”.

Model v7 supports two modes: automatic and manual. In the automatic mode, the desk phone manages the user presence state. While in manual mode, the user can select a state from a predefined list. Only in model v6 can a user create their own states.

### To configure a Presence state for Presence Model v6:

1. Press the **Presnce** soft key (press the **More...** context-sensitive soft until **Presnce** appears).
2. Press the **Change** soft key to change your current Presence state.

#### OR

Press the **Back** soft key to return to the Services menu.

3. Press the **Up/Down** navigation key to highlight either:
  - Connected
  - Unavailable
4. Press the **Select** soft key to continue to the next screen.

#### OR

Press the **Back** soft key to return to the previous step.

You can choose a more detailed message for other users to see, or you can select **None** if you do not want to provide additional information.

5. Select one of the following Presence states:
  - Appointment
  - Away
  - Breakfast
  - Busy
  - Dinner

- Holiday
- In-Transit
- Looking For Work
- Lunch
- Meal
- Meeting
- On The Phone
- Performance
- Permanent Absence
- Playing
- Presentation
- Shopping
- Sleeping
- Spectator
- Steering
- Travel
- TV
- Vacation
- Working
- Worship
- Unknown

**\* Note:**

You can create your own Presence messages to appear on screen, which become available when you program a feature key as a shortcut.

The Avaya Aura® Presence Server interworking with the IP Deskphones results in the following:

- a. The activities of **Busy**, **On the Phone** and **Away** are displayed on 96xx and One-X Communicator SIP phones on Aura (as icons). The other activities will display on 11xx/12xx phones but not the other Avaya phones.
  - b. The activity **Unknown** appears as **Offline** on other phones.
  - c. Idle 11xx/12xx phones appear as an **Offline** icon on the other Avaya phones (for example, 96x1 presence indication).
6. Press the **Select** soft key to select the Presence state and move to the confirmation screen.

**OR**

Press the **Add** soft key to enter a custom note.

**OR**

Press the **Back** soft key to return to the previous step.

7. Press the **OK** soft key to confirm the Presence state selection.

### To configure a Presence state for Presence Model v7:

1. Press the **Presnce** soft key (press the **More...** context-sensitive soft until **Presnce** appears).
2. Press the **Change** soft key to change your current Presence state.

#### OR

Press the **Back** soft key to return to the Services menu.

3. Select one of the following Presence states using the **Up/Down** navigation key:
  - Available
  - Away
  - Busy
  - Do not disturb
  - Out Of Office
  - Offline

#### \* **Note:**

These states have the highest priority.

4. Press the **Select** soft key to confirm your selection on the confirmation screen.

#### OR

Press the **Back** soft key to return to the previous step.

5. Press the **OK** soft key to confirm the Presence state selection.

### Related links

[Active calls and call features](#) on page 111

[Adding a new Presence state message to Presence Model v6](#) on page 139

---

## Adding a new Presence state message to Presence Model v6

You can add a new Presence state message to Presence Model v6. You cannot add a new Presence state message to Presence Model v7.

### To add a new Presence state message:

1. Press the **Presnce** soft key (press the **More....** context-sensitive soft key until **Presnce** appears).
2. Press the **Change** soft key.
3. Select **Connected** or **Unavailable** from the menu.
4. Press the **Add** soft key.
5. Press the **abc/123** soft key to toggle between alphabetic and numeric characters.

6. Use the dialpad to enter a new Presence state message.
7. Press the **Ok** soft key to confirm the entry and complete the procedure.

**OR**

Press the **Back** soft key to return to the previous step.

#### Related links

[Configuring a Presence state](#) on page 137

---

## Audio Codecs

This feature allows you to specify a codec to which you can switch to during an active call. You can use the Preferences menu to modify the order of preference of the codecs between calls.

You can select an audio codec by name during a call, or while the handset is idle. The Audio Codecs feature also gives you control over the audio configuration that is used for inbound and outbound calls.

To change the codec while on the call, select **Audio > Change codec**, and then press **OK**.

The following context-sensitive soft keys are available on the Audio Codes page:

- **Ok** — to view the Audio Codec Selection screen.
- **Back** — to return to the previous screen.

#### Related links

[Active calls and call features](#) on page 111

[Audio Codec Selection](#) on page 140

[Audio Codec Ordering](#) on page 141

---

## Audio Codec Selection

The Audio Codec Selection allows you to select a codec to use during inbound and outbound calls.

The following context-sensitive soft keys are available for selecting the audio codes:

- **Select**: The IP Deskphone attempts to renegotiate the codec for the current call to use the selected codec.
- **Back**: Allows you to return to the Audio Codec screen.

#### Related links

[Audio Codecs](#) on page 140

---

## Audio Codec Ordering

The Audio Codec Ordering allows you to modify the order of preference of codecs to use during inbound and outbound calls.

The following context-sensitive soft keys are available for the audio codec ordering page:

- **Save**—to save the current order as the new preferred codec order.
- **MoveUp**—to move the highlighted codec up in the list.
- **MoveDwn**—to move the highlighted codec down in the list.
- **Back**—to return to the Audio Codec screen.

The Audio Codec Ordering screen allows you to modify the order of preference of the codecs. You can reorder the preferences, and the changes to the ordering are saved.

### Related links

[Audio Codecs](#) on page 140

---

## PC Client softphone interworking with the IP Deskphone

An Avaya soft client application such as one-X Communicator or one-X Agent Desktop can create a shared control session with the 11xx/12xx IP Deskphone. To enable shared control, configure the soft client application with option “Outgoing Calls” set to “Desk phone”.

After the IP Deskphone has logged in, log in the soft client application using the same login credentials as the IP Deskphone. The soft client application creates a shared control session with the IP Deskphone. Calls made to and from the PC client use the IP Deskphone’s transducers.

With shared control configured, the following call actions are supported between the PC soft client and the IP Deskphone:

- Answer an incoming call
- Make a call
- End a call
- Ignore a call

For example, dialing a number from the PC soft client takes the IP Deskphone off-hook and dials as if it were the IP Deskphone dialing the call.

### Note:

1. During a call, although the one-X device shows the Transfer and Conference keys, you must use the IP Deskphone soft keys to perform these functions.
2. If you have not logged in the IP Deskphone when the PC soft client logs in, the PC soft client displays an error message. Check your IP Deskphone and ensure the IP Deskphone is logged in before logging in the PC soft client.

## Related links

[Active calls and call features](#) on page 111

---

## Automatic remote software updates

### \* Note:

Your system administrator must enable Remote check for update for this feature to work.

Your IP Deskphone may be configured to perform automatic software updates. If this feature is configured, the IP Deskphone displays when a software update is scheduled to occur, and **Yes** and **No** context-sensitive soft keys are displayed. If the IP Deskphone is idle and no key is pressed, the software update begins in one minute.

If you press **Yes**, the software download begins.

If you are using your IP Deskphone (this includes on hold, on a conference call, or when your IP Deskphone is ringing) and you press **No**, the call is not disconnected and the software update does not occur. The IP Deskphone displays the software download prompt again in three minutes a total of three times.

If, after the third notification, you press **No** or no key is pressed, the software update does not occur. Your IP Deskphone attempts the software download process again in two hours.

### \* Note:

If you allow the update to proceed and the server is down, the IP Deskphone does not ask for updates again.

## Related links





[Active calls and call features](#) on page 111

---

## Busy Lamp Field

The Busy Lamp Field (BLF) feature is an alternate presence-monitoring mechanism for the IP Deskphone that allows presence functionality on proxies that support BLF.

BLF is an icon state for a corresponding Speed Dial key on an IP Deskphone; the icon state tells you if another extension connected to the same SIP server is busy. You do not enable or disable this feature; BLF is configured by your system administrator. If enabled, the IP Deskphone subscribes to the proxy and receives the presence state list for all the users it is configured to watch. Call states and the corresponding presence icons are shown in the following table:

State	Meaning	Icon
Unknown	The presence of the monitored IP Deskphone is unknown	
Terminated	The monitored IP Deskphone is not involved in a call and is available	
Ringing	The monitored IP Deskphone is ringing	 Flashing
On the phone	The monitored IP Deskphone is busy on a call	

**\* Note:**

If you have the required permissions, you can answer a call placed to a monitored IP Deskphone. To answer, press the flashing **Ringing** button.

**Related links**

[Active calls and call features](#) on page 111

## Group Call Pickup

With the Group Call Pickup feature, all members in a pickup group can answer a call that is ringing at another group member telephone. If more than one telephone is ringing, the system selects the extension that has been ringing the longest.

One or more pickup groups are created by your system administrator . A pickup group is a collection, or list of individual telephone extensions. A pickup group is the way to connect individual extensions together. A user extension can belong to only one pickup group.

To activate the Group Call Pickup feature on your IP Deskphone, enter the FAC or FNE provided to you by your system administrator.

**Related links**

[Active calls and call features](#) on page 111

[Active calls and call features](#) on page 111

# Chapter 13: Advanced features

## Related links

- [Viewing the IP Deskphone information](#) on page 144
- [Network menu](#) on page 149
- [USB flash drive](#) on page 150
- [Customizable banner for login](#) on page 151
- [Phone Information - Details screen](#) on page 151
- [Screensaver/screen lock](#) on page 152
- [Background image](#) on page 155
- [Service Package Group Support](#) on page 156
- [Speed Dial List](#) on page 160
- [USB flash memory device support](#) on page 162
- [Announcement Record / Listen](#) on page 166
- [Abbreviated Dialing Lists](#) on page 166
- [Change Class of Restriction](#) on page 167
- [Change Coverage](#) on page 167
- [EC500 Self Administration](#) on page 167
- [Malicious Call Trace Activation](#) on page 168
- [Station Lock and Unlock](#) on page 168

---

## Viewing the IP Deskphone information

To view the Phone Information for the IP Deskphone, press the **Services** hard key and select **Phone Information** from the menu.



You can view the following information:

- Load Ver
- Software
- E.M Software
- Presence



- FeatActv
- Srv Pkg Location

Press the **Details** soft key to show:

- Primary User
- Primary Domain
- MAC
- IP
- License server
  - Status

Press the **Back** soft key to go back to the **Phone Information** screen.

**\* Note:**

You cannot make any changes to the setting from this menu.

To view information about E911, press the **E911** soft key after you access the **Phone Information** screen.

#### Related links

- [Advanced features](#) on page 144
- [Accessing the Services menu](#) on page 145
- [Checking for Updates](#) on page 146
- [Resetting the IP Deskphone](#) on page 146
- [Erasing the user data](#) on page 147

---

## Accessing the Services menu

Some of the system features require your user password. You must consult with the system administrator or service provider before you can access some of the features.

#### To access the services menu:

Press the **Services** hard key.



The IP Deskphone displays the following menu:

1. Search	Use to perform local/global search.
2. Login	Use when the call server supports multiple user logons only.
3. Logout	Use to log off the IP Deskphone.

*Table continues...*

4. Check for Updates	Use to check for the latest software and configuration update for the IP Deskphone.
5. Reset Phone	Use to perform a reset of the IP Deskphone.
6. File Manager	Use to manage files and delete old user data.
7. Logging System	Use to enable/disable SIP logging.
8. Phone Information	Use to view IP Deskphone details.

### Related links

[Viewing the IP Deskphone information](#) on page 144

---

## Checking for Updates

You can check for the latest software and configuration update for your IP Deskphone.

### Caution:

You must not request a provisioning update while on an active call because the phone may reboot during processing of the received configuration data. While the phone checks for an update, it activates Do Not Disturb (DND). When the update is finished, DND is deactivated.

### To check for the latest update

1. Press the **Services** fixed key.



2. Select **Check For Updates**.
3. Press the **Select** context-sensitive soft key.
4. Press the **Yes** context-sensitive soft key check for the latest software and configuration update for your IP Deskphone.

**OR**

Press the **No** context-sensitive soft key to return to the previous menu without checking for an update.

### Related links

[Viewing the IP Deskphone information](#) on page 144

---

## Resetting the IP Deskphone

Use this feature to log out and reregister to the server.

### To reset the IP Deskphone

1. Press the **Services** fixed key, and then select **Reset Phone**.
2. Press the **Select** soft key.
3. Press the **abc/123** soft key to toggle between alphabetic or numeric input.

4. Use the dialpad to enter your password.
5. Press the **Ok** context-sensitive soft key.

**OR**

Press the **Back** soft key to return to the previous menu.

The IP Deskphone prompts you with

```
Reset Phone?
```

6. Press the **Yes** soft key to proceed.

**OR**

Press the **No** soft key to return to the System menu.

- 7.

### Related links

[Viewing the IP Deskphone information](#) on page 144

---

## Erasing the user data

The IP Deskphone stores user files that you eventually want to delete. These files include:

1. **Profiles** — user profile settings
2. **Sounds** — downloaded tones or audio alerts
3. **Languages** — downloaded language files
4. **Images** — downloaded image files
5. **Logs** — ECR-log file, SIP-log files and its archives.
6. **System file** — IP Deskphone system configuration file (deleting this file returns the IP Deskphone to the factory default configuration settings.)

You can delete some or all of these files. The deletion of files is often necessary when the IP Deskphone is redeployed to a different user.

### \* Note:

Your phone configuration can prohibit you from deleting files. In this case, if you are prohibited from deleting files, the following message appears:

```
Action is not allowed. You don't have permissions.
```

### To delete user data files:

1. Press the **Services** fixed key.
2. Select **File Manager**.

### \* Note:

You must enter your login password to access the File Manager menu.

3. Press the **abc/123** soft key to toggle between alphabetic or numeric input.

4. Use the dialpad to enter your password.
5. Press the **Ok** soft key.

**OR**

Press the **Back** soft key to return to the previous menu.

6. Press the Up/Down navigation key to highlight one of the following:
  - Profiles
  - Sounds
  - Languages
  - System file
  - All files
7. Choose one of the following:
  - To enter the selected folder, press the **Select** soft key.
  - To delete contents of the selected folder, press the **Delete** soft key.

**\* Note:**

Note: Folders cannot be deleted because they are on the IP Deskphone.

- If you are at the root folder of the flash disk, press the **Exit** soft key to return to the previous menu.

If you are already inside the folder, press the **Back** soft key to return to the previous menu.

**To delete a user profile:**

1. Press the **Up/Down** navigation key to highlight the user profile you want to delete.
2. Press the **Delete** soft key to delete the highlighted user profile from the list.

**OR**

Press the **Back** soft key to return to the previous menu.

3. Log off or restart the IP Deskphone to complete the process.

**To delete a sound file:**

1. Press the **Up/Down** navigation key to highlight the sound file you want to delete.
2. Press the **Delete** soft key to delete the highlighted sound file from the list.

**OR**

Press the **Back** soft key to return to the previous menu.

**To delete a language file:**

1. Press the **Up/Down** navigation key to highlight the language file you want to delete.
2. Press the **Delete** soft key to delete the highlighted language file from the list.

**OR**

Press the **Back** soft key to return to the previous menu.

**To delete a log file:**

1. Press the **Up/Down** navigation key to highlight the log file you want to delete.
2. Press the **Delete** soft key to delete the highlighted log file from the list.

**OR**

Press the **Back** soft key to return to the previous menu.

language

**To delete the system file without deleting the user profile:**

1. Press the **Delete** soft key to delete the system file from the list.

**OR**

Press the **Back** soft key to return to the previous menu.

2. Log out or restart the IP Deskphone to complete the process.

**To delete all files:**

1. Press the **Next** soft key to delete the system file and user profile.

**OR**

Press the **Back** soft key to return to the previous menu.

2. Log out or restart the IP Deskphone to complete the process.

**Related links**

[Viewing the IP Deskphone information](#) on page 144

---

## Network menu

In most cases, the system administrator is the only person authorized to access the Network menu and to use an administration password to access the items. For more information on how to access the Network menu items, see *SIP Software for Avaya 1100 Series IP Deskphones - Administration (NN43170-600)*.

The following Network menu items are available:

- **Server Settings** — to select and edit domains
- **Device Settings** — to configure the network settings
- **Diagnostics** — to run a trace route or send a ping to diagnose the network connection
  - IP Set and DHCP information
  - Network Diagnostics tools
  - Ethernet Statistics
  - IP Network Statistics
  - Advanced Diag Tools

- Test Key

- **Lock Menu** — to access to the Network Menu

#### To access the Network menu:

Press the **Services** fixed key twice quickly.

**OR**

Press the **Prefs** soft key, and then select **Network** from the menu.

#### **Note:**

You need to enter an administration password to access the **Network** menu items.

#### Related links

[Advanced features](#) on page 144

---

## USB flash drive

A standard USB flash drive can be used for the following:

- To expand the hardware storage in the IP Deskphone.
- To support file transfer between a PC and the IP Deskphone to upload specific files or preferences into the IP Deskphone.
- To back up data stored in the IP Deskphone.

#### Presence of USB flash drive

Navigate through the menus **Services > Phone Information > USB** to verify the presence of the USB flash drive attached to the IP Deskphone. After you select the **USB** menu, the attached USB flash drive is displayed along with other USB devices. The name of the USB device directly appears from the USB device itself. There is no explicit USB flash drive indication.

#### Feature characteristics

USB flash drives with 8 GB or less are supported. A file browsing facility is available.

Most USB flash drives have an LED to indicate file operation in progress. After you attach the USB flash drive to the IP Deskphone, the IP Deskphone registers and mounts the USB file system. Mounting the file system causes the LED to flicker. If you disable USB device support, then the IP Deskphone does not mount the USB file system and the LED does not light.

There is no explicit safe removal function required. The USB flash drive can be removed safely when the LED indicator on the memory stick is off.

#### Enabling or disabling the USB Port

In the **Services > Phone Information > USB Devices** menu display, if the value of **Enable USB Port** is **No** then the USB information does not display any USB devices connected. The screen displays the information that the USB port is disabled.

If the USB port is not disabled, then the USB menu displays information on all USB devices attached, even if the device is locked. An unsupported device is enumerated if it is attached to the IP Deskphone.

To ensure you know about the USB lock status, the USB device information is followed by status information about supported USB devices. If the USB configurations do not match the USB device status because of the restart requirement, a warning that `USB Update requires reboot` appears on the screen.

#### Related links

[Advanced features](#) on page 144

---

## Customizable banner for login

If a login banner with login banner text is configured, the IP Deskphone displays the banner text on the screen as the user logs on.

Changing the IP Deskphone-configured language does not change the banner text language. The banner appears only for the primary user of an IP Deskphone. In a multiuser configuration, even when the banner text is enabled, the banner does not appear to the secondary user logins.

Dismiss the banner screen by pressing **OK**. Until you dismiss the banner screen, the IP Deskphone switches to DND mode until the banner is dismissed. Outgoing or incoming calls are not allowed other than emergency calls until you dismiss the banner.

You can see pop-up messages or prompts on the bottom of the banner screen after you dismiss the login banner.

#### Related links

[Advanced features](#) on page 144

---

## Phone Information - Details screen

The **Phone Information — Details** screen displays the Primary user, Primary domain, MAC address, and IP address of the IP Deskphone. The contents of this screen include user and IP Deskphone identifiable information that may need to be protected (per US Federal/DoD requirements/guidelines).

#### **Note:**

To hide information that is protected, the administrator can disable the **Details** context-sensitive soft key on the main **Phone Information** screen.

If the **Details** soft key is disabled, you cannot view details on the **Phone Information - Details** screen.

If the **Details** soft key is enabled, you can view the **Phone Information - Details** screen. In the **Services** menu, select **Phone Information** and then press the **Details** soft key.

The **Phone Information - Details** screen displays the following information:

- **Primary User:** Primary logged-in User name.
- **Primary Domain:** Primary login domain.
- **MAC:** Device MAC address.
- **IP:** IP Deskphone IP Address
- **Device Licensing/Token usage information:** License or token usage information for the IP Deskphone. It is an optional item in the IP Deskphone information.

To dismiss the **Phone Information - Details** screen and return to the previous display, press the **Back** soft key.

#### Related links

[Advanced features](#) on page 144

---

## Screensaver/screen lock

You can lock the display of the IP Deskphone using a timed Screensaver/ Lock.

When the screensaver is active, it clears the programmed keys of the plugged-in Expansion Module. If you have logged into the IP Deskphone, then you are not logged out, but the line key label clears and makes the IP Deskphone inactive.

The **ScrnSvr** soft key is located on the idle screen. This key is available only if the screensaver has been enabled, and is accessed by pressing the **More...** soft key until **ScrnSvr** appears. Pressing the **ScrnSvr** soft key causes the screensaver timer to turn off, and activates the previously-selected screensaver.

Choose **Prefs > Display > 3. Display Screensaver** to display the **Screensaver** settings screen.

Select **3. Display Screensaver** to display the **Screensaver** settings screen.

The **Screensaver** settings screen allows you to enable or disable your screensaver/lock. You can also configure various settings such as the delay before the screensaver starts, the background image to use, and the banner text to display when the screensaver/lock is active.

The following items are displayed:

- **Mode** — to enable or disable the screensaver and choose if the screensaver is to be password protected.
- **Delay** — to configure the time delay before the screensaver is invoked.
- **Image** — to select the background image to display when the screensaver is active.
- **Text** — to configure the text that appears on the phone display screen when the screensaver is active.



Press **Select** to select the currently highlighted setting.

Press **Back** to exit the **Screensaver** menu.

### Screensaver Mode

The **Screensaver Mode** screen allows you to enable or disable the screensaver/lock.

Choose one of the following screensaver configuration options:

1. **Disable** — to disable the screensaver.
2. **Enable (no password)** — to enable the screensaver with password-free mode.
3. **Enable (with password)** — to enable the screensaver with password mode.

Press **Select** to select the currently highlighted setting.

Press **Back** to exit the **Screensaver Mode** menu.

#### \* Note:

Some options may not appear, depending on configuration.

#### Disable:

Disabling the Screensaver displays a message confirming your selection.

#### Enable (no password):

Enabling the screensaver in **no password** mode displays a message confirming your selection.

#### \* Note:

If the device configuration does not allow the use of a password-free screensaver, this menu option is not available to you.

#### Enable (with password):

Enabling the screensaver in password-protected mode prompts you to enter a password before logging in.

If allowed in the configuration, the user-defined password definition screen is displayed.

The screen displays `Enter user password to activate screensaver` followed by a user-input prompt.

#### To configure a password:

1. Press the **Set** soft key.

This soft key appears only if the phone configuration allows the setting of user-defined passwords. Pressing this key invokes a password definition screen that allows you to configure a password.

If a user-defined password is not allowed, then the **Set** soft key is not visible, and you can use only the primary user login password to enable the password-protected screensaver.

2. Enter a password. Press the **abc/123** soft key to toggle input mode between numeric or alphabet.
3. Press **OK**.

A `Screensaver enabled` message appears if the password is valid. An `Invalid password` message is displayed if the password is invalid.

Press **Back** to dismiss the **Enable (with password)** mode menu.

## Active Screensaver

After the screensaver is enabled, and if the IP Deskphone is idle for the defined delay/time interval, then the screensaver takes control of the IP Deskphone.

### If Reboot is performed while screensaver is displayed

If you reboot the IP Deskphone when there is an active screensaver:

- If you have enabled autologin, then the screensaver remains active after the IP Deskphone reboots and completes the login.
- If you have not enabled autologin, then the screensaver setting remains enabled, but not active, after you log back into the IP Deskphone manually.

### Active Screensaver (no password mode)

**Unlock** — if the screensaver is not password protected, pressing the **Unlock** key (or any other) cancels the screensaver.

Any user interaction, key presses, mouse movement, or incoming call cancels the screensaver (without requiring a user password). This includes pressing the **Unlock** context-sensitive soft key.

Incoming IMs do not cancel the screensaver.

The programmed keys of attached Expansion Module(s) are cleared until the screensaver is deactivated. If you have logged on to the IP Deskphone, you are not logged out, but the line key labels clear and are inactive until the screensaver is deactivated.

### Active Screensaver (password mode)

If the screensaver is in a password-protected mode, pressing the **Unlock** soft key invokes a password input screen. The password must be correctly entered to cancel the screensaver.

User interaction, key presses, and mouse movements do not cancel the screensaver.

Pressing the **Unlock** soft key prompts you to enter the password for the screensaver. The primary user line key is displayed (but not active) during the password prompt to give an indication about whose password is in use.

Picking up the handset and dialing digits activates the line function display for emergency calls only. If you try to place an outgoing call, a message is displayed and the screensaver starts again.

If you make an emergency call while the screensaver is active, the call is placed using the primary user.

An incoming call displays caller ID and allows you to answer the call. The **Unlock** soft key appears on the screen and you can unlock the IP Deskphone after answering the call. You cannot make outgoing calls except an emergency call, and cannot view IMs or the Friends list until you unlock the IP Deskphone.

If you make an emergency call while the screensaver is active, the call is placed using the primary user.

The **Network** menu is accessible to administrators (double press of the **Services** key) even when the screensaver is active. If user-defined passwords are allowed, a mechanism to disable the screensaver (allowing the administrator to reset the user-defined password) is accessible through the Network menu. This mechanism also invokes remotely from the IP Deskphone console through an SSH connection.

All expansion modules are cleared of programmed keys until the screensaver is deactivated.

### Selecting an image to be viewed as an animated slideshow

You can display all of the screensaver images that have been uploaded to your IP Deskphone in a slideshow format.

These files are loaded on the IP Deskphone using the USB flash drive.

Images for the 1165E IP Deskphone cannot exceed 512 MB. The images must be resized before they are loaded onto the IP Deskphone. The image size for the 1165E IP Deskphone is 320x 240.

The images can be displayed as a slideshow.

Choose **Prefs > Display > 4. Display Screensaver > Images > Slideshow**.

#### Related links

[Advanced features](#) on page 144

---

## Background image

The IP Deskphone can display background images on the screen. From the menu, select **Preferences > Display > 4. Background Image** to browse the stored images on the file system and select an image for the user interface.

Selection of the **4. Background Image** menu item takes you to a new display list that contains all the available image files on the Flash File System.

#### Related links

[Advanced features](#) on page 144

[Selecting an image screen](#) on page 155

---

## Selecting an image screen

You can select a background image from a list of images currently stored on the Flash File System (FFS) of the IP Deskphone.

1. Press the **Prefs** soft key, then choose **Display > 4. Background Image**.

The **Images** screen appears and displays the filenames of all image files currently stored on the Flash File System of the IP Deskphone.

2. Highlight the desired image.

3. Press **Select** to select the currently highlighted image or press **Back** to dismiss the **Images** screen.

After you select the background image you want to use, a confirmation screen appears, displaying the selected image in the background and a message to press **OK** to keep the selected image.

4. Press **OK** to confirm the selected image as the background image or press **Cancel** to cancel the selection.

 **Note:**

If the selected image is not confirmed, the screen time-outs after 15 seconds; the selected image is disregarded and the IP Deskphone display returns to the **Images** list screen.

### Related links

[Background image](#) on page 155

---

## Service Package Group Support

The Service Package Group Support feature can help you program feature keys on an expansion module. You can view the Group Support feature in the feature key programming user interface and in the Friends list interface of the Address book.

You can use to the Service Package Group Support feature to help you do the following:

- bulk-create feature keys, such as Speed Dial keys, based on one of your existing Directory Address Book groups.
- view existing groups in your address book if you selected Groups as the source data for the bulk key creation.
- view the existing groups you have in your Address Book.
- add a new contact to your Address Book.
- add a new group.

### Related links

[Advanced features](#) on page 144

[Bulk-create feature keys based on an existing directory Address Book group](#) on page 157

[View existing groups in your Address Book if you selected Groups](#) on page 158

[View the existing groups you have in your Address Book](#) on page 158

[Add a new contact to your Address Book](#) on page 159

[Add a new group](#) on page 160

---

## Bulk-create feature keys based on an existing directory Address Book group

### To bulk-create feature keys based on an existing directory Address book group:

1. From the idle screen, press the **Prefs** soft key (press the **More...** soft key until you see **Prefs**).
2. Press the Up/Down navigation key to highlight **Feature Options**, then choose **Feature keys**.  
The main feature key programming screen appears.
3. Press the **Bulk** soft key.  
The **Program Key Bulk** commands screen appears.
4. Press the Up/Down navigation key to highlight **Feature key creation**.
5. Press the **Select** soft key.  
The **Create keys** screen appears.
6. Press the Up/Down navigation key to highlight the type of programmed keys you want to create by bulk command.

You can choose one of the following options:

- Speed Dial
- Send IM
- Call Forward

7. Press the **Select** soft key.

The **Select Source** screen appears.

### OR

Press the **Back** soft key to dismiss the screen.

8. Press the Up/Down navigation key to highlight the source data for the bulk key creation.

You can choose one of the following options:

- Friends
- Groups (if you have existing groups in your address book)
- Address Book

9. Press the **Select** soft key.

- If you choose **Friends**, the bulk key creation process begins.
- If you choose **Address Book**, the bulk key creation process begins.
- If you choose **Groups**, the **Select Group** screen appears and prompts you to select the specific group you want to use for key creation.

### OR

Press the **Back** soft key to dismiss the screen.

## Related links

[Service Package Group Support](#) on page 156

---

## View existing groups in your Address Book if you selected Groups

You can view existing groups in your Address Book if you selected Groups as the source data for the bulk key creation.

### To view existing groups in your Address Book if you selected Groups:

1. Press the Up/Down navigation key to highlight the source data (group) for the bulk key creation.
2. Press the **Select** soft key to begin the bulk key creation process for the selected group.

#### OR

Press the **Back** soft key to dismiss the screen and return to the screen where you can select the source data for bulk key creation.

#### **Note:**

After you select from one of your existing groups, the bulk creation of the keys happens automatically.

## Related links

[Service Package Group Support](#) on page 156

---

## View the existing groups you have in your Address Book

### To view the existing groups you have in your Address Book:

1. When the IP Deskphone is in the idle mode, press the **Directory** fixed key to access your Address Book.
2. Press the **Filter** soft key to filter the list of entries displayed in your Address Book.  
The **Select Filter** screen appears and displays all the existing groups in your address book, as well as the Friends filter.
3. Press the Up/Down navigation key to highlight the required filter.
4. Press the **Select** soft key to choose the group you want to view (for example, if you choose Personal, only Address Book entries that are part of the group Personal are displayed).

You are presented with the list of contacts currently part of the group you selected.

#### OR

Press the **Back** soft key to return to the dismiss the screen and return to the main address book screen.

5. Press the Up/Down navigation key to highlight the required entry.

6. Choose one of the following options:
  - Press the **View** soft key to display the address book entry details for the selected entry.
  - Press the **All** soft key to return to the main address book screen (no filtering)
  - Press the **Edit** soft key to modify or delete an entry.
  - Press the **Back** soft key to dismiss the screen and return to the filter selection screen.

After the screen displays the details of the selected Address Book entry, you can do the following:

- Press the **SendIM** soft key to send an IM to the selected entry.
- Press the **Edit** soft key to modify the displayed address book entry.
- Press the **Back** soft key to dismiss the screen and return to the main address book screen.

### Related links

[Service Package Group Support](#) on page 156

---

## Add a new contact to your Address Book

### To add a new contact to your Address Book:

1. When the IP Deskphone is in the idle mode, press the **Directory** fixed key to access your Address Book.
2. Press the **Add** soft key.
3. Use the dialpad to enter a name for the new contact and press the **Next** soft key to continue.

**OR**

Press the **Back** soft key to return to the previous menu.

4. Use the dialpad to enter a telephone number or SIP address (URI) for the new contact. Press the **Next** soft key to continue.

**OR**

Press the **Back** soft key to return to the previous menu.

5. Press the **Yes** soft key to add the new entry to an address book group.

**OR**

Press the **No** soft key to add the entry to the address book without adding it to a group.

**OR**

Press the **Back** soft key to return to the previous menu.

**\* Note:**

If you choose to add the new contact to a group, a list of all your existing groups is displayed, and the screen prompts you to select a group.

6. Press the Up/Down navigation key to highlight the required entry.

7. Choose one of the following options:

- Press the **Select** soft key to assign your new address book entry to the group that you selected.
- Press the **Edit** soft key to modify the name of an existing group.
- Press the **Add** soft key to add a new group (invokes the add group screen).
- Press the **Back** soft key to dismiss the screen and return to the previous screen.

**Related links**

[Service Package Group Support](#) on page 156

---

## Add a new group

**To add a new group:**

1. From the **Select Group** screen, press the **Add** soft key.
2. Use the dialpad to enter the group name, and then press the **Ok** context-sensitive soft key.

 **Note:**

If the name of the new group already exists, an error screen appears.

**OR**

Press the **Back** soft key to return to the previous menu.

**Related links**

[Service Package Group Support](#) on page 156

---

## Speed Dial List

When configuring the phone provisioning, a feature key can be configured as a Speed Dial List. You cannot modify or delete the feature key used by the Speed Dial List. Also, you cannot modify the content of the Speed Dial List.

Invocation of the speed dial list is similar to other feature key invocation. The Speed Dial List key causes a full screen list to appear and offers you a chance to automatically dial one of the offered choices.

The contents of the Speed Dial List varies, based on the current call state of the IP Deskphone and the type of speed dial list entry configured.

 **Note:**

Only entries in the Speed Dial List can be context-sensitive, not all speed dial keys/ individual feature keys.



A Speed Dial key or one included in a Speed Dial List can cause a call that was placed on hold (when invoked) to be un-held automatically (when call completes), based on a new value that must be configured when a Speed Dial key is created or configured.

A feature key provisioned for use as a Speed Dial List has a similar appearance to all other programmed feature keys on the idle screen (or in-call screen). The label used for the selected key is provided through provisioning.

The following is the icon for the **Speed Dial List** key.



After you press the feature key provisioned as a Speed Dial List, the list of Speed Dial entries configured appears on the screen and the you can select an item from that list to invoke a Speed Dial.

If the Speed Dial List is empty, or results in being empty due to context-sensitive hiding of contents, an error message displays stating `There are no Speed Dials currently available.`

#### Related links

[Advanced features](#) on page 144

[Speed Dial List screen](#) on page 161

[Auto-Retrieve flag](#) on page 162

---

## Speed Dial List screen

You can select the provisioned Speed Dial List entries from the **Speed Dial List** screen.

The Speed Dial List screen displays all the Speed Dial List entries provisioned. The displayed Speed Dial List items are based on the provisioned list as well as the current Idle/Mid-call state of the IP Deskphone. After you invoke the Speed Dial List while the IP Deskphone is idle, only Speed Dial List entries that are configured to IDLE are displayed. Similarly, only items marked as MID CALL are displayed if the Speed Dial List is invoked while the IP Deskphone is in a call.

The following are the options available for the Speed Dial List screen:

- **Dial** — invokes the selected speed dial.
- **Exit** — screen dismisses without invoking a Speed Dial List entry.

#### Related links

[Speed Dial List](#) on page 160

---

## Auto-Retrieve flag

If you enable the Auto-Retrieve behavior on a Speed Dial key or Speed Dial list entry that is invoked, and place a call on hold to invoke the current key/entry, the IP Deskphone attempts to unhold the call after the key or entry call completes.

For example:

- A is talking to B when A invokes their Speed Dial List and selects an entry.
- Selection/invocation of a Speed Dial List entry places the A-B call on hold and places an outgoing call to the URI specified in the Speed Dial List entry; for example, C.
- When the A-C call completes, if the Auto-Retrieve flag is enabled for the Speed Dial, then the IP Deskphone attempts to take call A-B off hold. This may not always happen if the IP Deskphone receives another call during the A-C call, or if the A-B call state is changed while A-C is active.

The Auto-Retrieve behavior is added to regular speed dial keys instead of speed dial list entries. To make sure that this flag is configured for programmed speed dial keys, the **Enable Auto-Retrieve** screen appears as the last step in Speed Dial Key configuration.

The Auto-Retrieve screen allows you to configure the Auto-Retrieve behavior for the Speed Dial.

### Related links

[Speed Dial List](#) on page 160

---

## USB flash memory device support

The IP Deskphone supports the browsing of files on a USB flash memory device. A simple file browser allows you to select an image file (or other type of file) and upload onto the IP Deskphone file system. The file manager also allows you to browse and copy certain files from the phone file system onto a USB flash drive.

After you select the File Manager menu by choosing the **Services** menu, you can navigate to the IP Deskphone file system and any USB drives attached. From there, you can either copy a file from the IP Deskphone onto the USB drive or copy a file from the USB drive to the IP Deskphone.

If you select File Manager, and there are no USB drives plugged into the IP Deskphone, the root screen of the IP Deskphone file system is displayed.

The following are the options available for the Root screen:

- **Select** — use to enter the selected folder.
- **Delete** — prompts you to delete contents of the selected folder (folders are not deleted because they are on the IP Deskphone).

- **Exit** — If you are at the root folder of the flash disk, the screen is dismissed and you are sent back to the previous menu. If you are already inside a folder, then the **Back** soft key acts the same as the .. item and moves up one level in the directory structure.

After you select a file, and if a USB drive is plugged into the IP Deskphone, the screen that appears next is the **Select Device** screen. This screen lists the IP Deskphone, and any USB drives that are available. After you select one of the items, the contents of that device (folders and files) appears; .. allows you to navigate back to the **Select Device** screen.

The following are the options available for the **Select Device** screen:

- **Select** — to enter the selected device.
- **Exit** — to dismiss the file manager and return to the **Services** menu.

After you select the device to which you want to navigate, the device file structure is displayed.

 **Note:**

The context-sensitive soft keys change based on the selected item on the screen.

The File Manager browsing screen provides the following options:

- **Select** — to enter into the selected folder.
- **Back** — to return to the previous screen
- **Delete:**
  - If you select a file to delete, the screen prompts to confirm deletion and then deletes the file. If you do not respond to the deletion prompt in 15 seconds, deletion is cancelled.
  - If you select a folder on the IP Deskphone to delete, the screen prompts to confirm deletion of all contents of the folder on the phone but does not delete the folder itself.
  - If you select a folder on the USB device to delete, the screen prompts to confirm deletion of the folder and all its contents. If you do not respond to the deletion prompt within 15 seconds, deletion is cancelled.

 **Note:**

Your phone configuration can prohibit you from deleting files. In this case, if you are prohibited from deleting files, pressing the **Delete** soft key causes the following message to appear:

Action is not allowed. You don't have permissions.

- **Send** — appears only after you select a file.
  - If you select a file on a USB device and press **Send**, you can send or copy the selected file to the IP Deskphone. Based on the file extension, the destination folder is selected automatically; for example: PNG files are sent directly to Images folder on the IP Deskphone.
  - If you select a file on the IP Deskphone and press **Send**, an error message appears if there is no USB drive plugged into the IP Deskphone. Sending files from the IP Deskphone to another location on the IP Deskphone is not allowed.

- If you select a file on the IP Deskphone and press **Send**, a Select Destination Screen is displayed. Select the folder on the USB drive to which you want to send the file .
- **Back** — to dismiss the current screen and return you to the **Device Selection** screen.

### File Manager Select Destination

The **File Manager Select Destination** confirmation prompt screen confirms that you want to select the destination folder to which you wish to send or copy the previously selected file.

The following are the options available for the **Select Destination** screen.

- **OK** — to go to the screen where you select a folder.
- **Back** — to return to the previous screen.

After you have confirmed that you want to send a file from the IP Deskphone to the USB drive, the **Select Destination** screen appears.

#### **Note:**

The context-sensitive soft keys change based on the selected item on the screen.

The following options are presented:

- **Select** — to enter the selected folder.
- **Done** — to configure the current location as the destination for the send and initiates copy operation.
- **Back** — to return to the previous screen.

### Related links

[Advanced features](#) on page 144

[File Manager](#) on page 164

[USB scenarios](#) on page 165

---

## File Manager

This section provides some general information about File Manager

### Changing levels:

Selection of the .. item (or **Back** context-sensitive soft key) moves you up one level, which results in leaving the device and returning to the **Select Device** screen in some cases. If the current selection is a sub-folder, selecting .. or the **Back** context-sensitive soft key moves you up one level in the directory structure.

### File actions:

Selecting a file causes the selected file to copy on to the IP Deskphone flash file system, or can invoke a specific handler for the selected file (configured after this screen is invoked by other mechanisms). An example of this is a device configuration file which causes the IP Deskphone to update with a selected file rather than to copy the file to a folder

### File extensions:

Based on the extension of the selected file, validation routines run to verify the file size, and the free space available on the USB flash device, including restrictions that can be defined for safe usage — for example, a limit of XX images or ring tones on the IP Deskphone (based on the model).

Files having unknown extensions are not available for any action. The IP Deskphone attempts to perform actions only for file types and extensions it recognizes.

### Related links

[USB flash memory device support](#) on page 162

---

## USB scenarios

### Copying an image file from the USB drive into the IP Deskphone

1. Log on to the IP Deskphone and plug the USB flash drive into the IP Deskphone USB port.
2. Press the **Services** hard key and choose **File Manager**.
3. Select **Flash Disk device**. The contents of the USB drive are displayed.
4. Select the file you wish to copy and then press **Send**.

You are prompted to select the device to where you want to send the selected file.

5. Select the IP Deskphone as the destination device.

The file is validated based on the file extension and the passing of the validation routines, and a handler is called for the file. In this case, the image file copies the images directory of the flash file system on the IP Deskphone.

Any action that is taking some time to complete displays the **In progress...** message on the screen

A success message appears on the phone screen displaying that the file was copied to the IP Deskphone successfully.

### Copy errors

After a file is selected, there can be multiple reasons why the copy action cannot complete. The file size may exceed allowed limits, there may not be enough space on disk, a file with the same name may already exist, or actions on the selected file type may not be allowed (configuration flag).

Error conditions display a message on the screen.

### Copying the ring tone from the IP Deskphone to the USB drive

1. Log into the IP Deskphone and plug the USB flash drive into the USB port of the IP Deskphone.
2. Press the **Services** hard key and choose **File Manager**.
3. Select the IP Deskphone from the **Select Device** screen.

The contents of their IP Deskphone are displayed.

4. Navigate to the **Sounds** folder.
5. Select the file you require and press **Send**.

You are prompted to select the destination folder on the plugged-in USB drive.

6. Navigate to the folder **MyRings** and press **Done** to start the operation.

The file is then validated (some files are not allowed to copy) and sent to the selected destination. After the copy is complete, a message appears on the phone screen displaying that the file was copied successfully.

#### **Copy errors:**

If file copying cannot complete due to insufficient space on the USB device, or due to the selected file type not being enabled in the File Manager (device configuration), then an error message is displayed on the screen.

#### **Related links**

[USB flash memory device support](#) on page 162

---

## **Announcement Record / Listen**

This feature allows you to record an announcement associated with an assigned extension.

#### **To record an announcement:**

1. Dial the Announcement Access Code FAC provided to you by your system administrator.
2. Dial the extension of the announcement, and a “1” to hear confirmation tone to begin recording.
3. To stop recording, hang up the phone.
4. After a one minute pause, dial the announcement extension to listen to the recording.

#### **Related links**

[Advanced features](#) on page 144

---

## **Abbreviated Dialing Lists**

Abbreviated Dialing Lists allow you to dial the associated FAC (for example, Abbreviated Dialing List1 Access Code), followed by an index number(for example, 02) specifying which member of the list is to be called. The list can also be modified by dialing the Abbreviated Dial - Prgm Group List Access Code FAC, entering the number of the list (1, 2, or 3), the index of the list to be changed (for example, 05), and the number to be dialed.

#### **\* Note:**

You can program the FAC into a speed dial button for ease of use.

#### **Related links**

[Advanced features](#) on page 144

---

## Change Class of Restriction

The Class of Restriction (COR) for a given extension can be changed using the Change COR Access Code FAC.

Dial the FAC, followed by a system-wide password defined for this purpose, followed by the extension whose COR is to be changed, followed by the COR (for example, 02). The change can be verified by displaying the station form for the extension and examining the COR field.

### Related links

[Advanced features](#) on page 144

---

## Change Coverage

The Change Coverage feature allows you to switch between the two call coverage paths defined for your telephone.

Dial the Change Coverage Access Code FAC, the extension of the phone plus #, the Security Code for the phone plus #, and “1” or “2” to change the lead coverage path to Coverage Path 1 or Coverage Path 2 respectively.

### Related links

[Advanced features](#) on page 144

---

## EC500 Self Administration

The Extension to Cellular (EC) 500 feature allows you to assign and change the EC500 telephone number associated with your IP Deskphone.

Dial the EC500 Self-Administration Access Codes FAC followed by the IP Deskphone extension number plus #, the IP Deskphone station Security Code plus #, followed by the EC500 telephone number plus #.

This assigns the telephone number and automatically activates EC500. You can also manually activate or deactivate EC500 from a phone by dialing the Enhanced EC500 Activation or Deactivation FAC followed by the desk phone extension plus #, followed by the IP Deskphone station Security Code plus #.

### Related links

[Advanced features](#) on page 144

---

## Malicious Call Trace Activation

The Malicious Call Trace Activation feature is initiated from your IP Deskphone to start a trace for a currently active call on a specified extension. All configured trace controller phones on the system are notified of the request and can take control of the trace. The active controller can deactivate the trace. You can request a malicious call trace, but your IP Deskphone cannot act as a controller.

To make the request, dial the Malicious Call Trace FNE or FAC followed by the extension of the phone that is on the call to be traced. The request can be canceled by dialing the Malicious Call Trace Cancel FNE or FAC.

### To initiate Malicious Call Trace on your IP Deskphone

1. To activate Malicious Call Trace for your active call, place the call on hold.
2. Dial the Malicious Call Trace FNE provided by your system administrator.
3. Dial your own extension number.
4. Wait 10 seconds for the confirmation tone.

#### Note:

You can configure the FNE as a speed dial number.

#### Related links

[Advanced features](#) on page 144

---

## Station Lock and Unlock

The Station Lock and Unlock feature allows you to restrict calls from being made from a specified extension.

Dial the Station Lock Activation FAC followed by the extension of the target phone plus #, and the station Security Code of the target phone plus #.

When Station Lock is activated, calls dialed from the target IP Deskphone result in a busy tone and the IP Deskphone displays a “Forbidden” message.

To deactivate station lock, repeat the procedure, dialing the Station Lock Deactivation FAC.

#### Related links

[Advanced features](#) on page 144



# Chapter 14: Multiuser

The Multiuser feature allows multiple SIP user accounts to be active on the IP Deskphone at the same time. This allows a single IP Deskphone to be shared among multiple users each with their own account, allowing each user to receive calls without logging off other users.

You can have multiple user accounts (for example, a work account and a personal account) active at the same time on the same IP Deskphone.

## Related links

- [Initial login](#) on page 169
- [Logging out](#) on page 171
- [Server failover](#) on page 171
- [Upgrade impacts to user profiles](#) on page 172
- [Line keys](#) on page 173
- [Making a call](#) on page 174
- [Receiving a call](#) on page 175
- [Being in a call](#) on page 175
- [Instant Messages](#) on page 176
- [Menu features](#) on page 176
- [Modifying settings](#) on page 176
- [Programmable keys](#) on page 178
- [Address books](#) on page 179
- [User status](#) on page 179
- [Notifications](#) on page 182
- [Account selection](#) on page 183
- [Receiving a call](#) on page 175

---

## Initial login

For an initial login, you must enter a user name and password and specify your login to either be permanent or to expire. You can also specify which SIP domain you want to access. The Domain key allows you to select a domain from the configured list but you cannot modify the domains.

You can change the language used at the login screen.

After you are logged in, the IP Deskphone displays the Idle screen.

You can configure up to five profiles. If the limit is exceeded, then the least recently used profile is automatically deleted.

### Related links

[Multiuser](#) on page 169

[Additional logins](#) on page 170

[Automatic login](#) on page 170

---

## Additional logins

The Login command in the System menu allows you to register additional accounts.

### \* Note:

You cannot change the language in a secondary login.

You can specify the Line Key to which the new account is associated. By default, the first unused key is selected. If the configured limit is reached on concurrent logins, then the selected login command displays an error message.

The initial login message `login in process` displays during the login operation.

During the login process, the IP Deskphone can receive calls for user accounts that are already registered; however, other features are not available until the login process is complete.

No profile selection prompt is displayed for the secondary account and no profile is created.

### Related links

[Initial login](#) on page 169

---

## Automatic login

If the automatic login feature is enabled and you were logged in when the IP Deskphone was switched off, the IP Deskphone automatically logs you back in upon startup. If multiple users were logged in, then they are all logged back in one after the other.

If the automatic login feature is disabled, then the automatic login does not occur.

It is possible to provision the IP Deskphone with user credentials for automatic login even on the initial startup. With the addition of multiuser support, it is also possible to provision multiple accounts in the same way. For more information about different autologin scenarios, see [Primary account logout](#) on page 171.

### Related links

[Initial login](#) on page 169

---

## Logging out

The logout command prompts you to select an account, asks for confirmation, then proceeds to log out the account. Logging out an account frees the corresponding Line key. Logging out does not require a password.

### Related links

[Multiuser](#) on page 169

[Primary account logout](#) on page 171

[Secondary account logout](#) on page 171

---

## Primary account logout

Logging out of the primary account causes all other accounts to log out automatically and the IP Deskphone to display the login screen. The secondary accounts are logged back in automatically when a new primary account is registered or the same primary account is re-registered.

If the IP Deskphone is restarted after logging out of the primary account, it returns to the login screen. Logging in a new primary account leads to automatic login of secondary accounts.

The list of programmed feature keys is part of the IP Deskphone profile. As a result, logging out of one primary account and logging in on a different account could change the set of feature keys. If a secondary account was assigned to a key that is also in the set of feature keys, the secondary account takes precedence; it is logged in, and the feature key acts as a line key. If the account is logged out manually, the programmed feature key becomes available.

### Related links

[Logging out](#) on page 171

---

## Secondary account logout

You can log out of a secondary account by selecting the secondary account in the Logout **Select User** screen. This causes the secondary account to be removed from the autologin list. If you restart the IP Deskphone, the secondary account is not logged back in.

### Related links

[Logging out](#) on page 171

---

## Server failover

If the connection to your account proxy is lost, then the IP Deskphone notifies your account and periodically attempts to reconnect. Some features remain accessible for other accounts (for example, incoming calls), but other features are not available until connection is reestablished or

you cancel the re-connection. Cancelling the call has the same effect as logging out. If you are the primary account, the IP Deskphone returns to the initial login screen. If you are logged in on a secondary account, that secondary account is removed from the list of secondary accounts that are logged in on automatic login.

If more than one account loses connection, the IP Deskphone attempts to reconnect the accounts in sequence. The first account to lose connection retries until it re-registers or you cancel the attempt, after which a reconnect attempt begins for the next account. Canceling the re-connection attempt of the primary account immediately abandons attempts for all other accounts, logs out secondary accounts that are still connected, and returns the IP Deskphone to the login screen.

A single login queue is used for automatic logins and failover. This means that if automatic logins are still pending when an account cannot connect, a reconnection attempt for that account only begins after all automatic logins have completed or are cancelled.

#### Related links

[Multiuser](#) on page 169

[Cable unplugged](#) on page 172

---

## Cable unplugged

If the IP Deskphone detects that the network cables are unplugged while accounts were logged in, then the IP Deskphone assumes that all accounts have lost their connection to the server. When you reconnect the cable, the IP Deskphone proceeds to re-register all accounts starting with the primary account.

#### Related links

[Server failover](#) on page 171

---

## Upgrade impacts to user profiles

In previous releases of the IP Deskphone software, user profiles were associated to user names rather than accounts; one user profile could be associated with multiple user names. After the IP Deskphone is upgraded to SIP Release 3.x or later software, the IP Deskphone may contain user profiles with old user name associations.

When a primary account with no associated profile is registered, the IP Deskphone looks for an old user profile associated with that user name. If an old user profile associated with that user name is found, the user profile becomes permanently associated with that account and is no longer associated to a list of user names.

#### Example:

An IP Deskphone with SIP Software Release 2.x has the following user accounts logged in and logged out.

- user1@domain1.com

- user2@domain1.com
- user1@domain2.com

A user profile is created for the first account and is reused for the second account. The third account reuses the same profile, as it has the same user name as the first account.

The IP Deskphone is upgraded to SIP Software Release 4.x.

- A user logs to the primary account “user3@domain1.com”. No profile is found for that account; a new profile is created automatically.
- The user logs out, then logs to the primary account “user2@domain1.com”. No profile is found for that account, but a Release 2.x user profile is found to be associated to the user name “user2”. The profile becomes associated to “user2@domain1.com”. The profile is loaded and user2 now has access to the call logs and most preferences available before the upgrade.
- User2 logs out, then logs in “user1@domain1.com”. User1 had a profile before the upgrade, but that profile has now been associated to the user2 account; therefore a new profile is created.

Not all the information in old profiles is preserved. The preference settings (for example, voice mail ID) are discarded in the upgrade.

### Related links

[Multiuser](#) on page 169

---

## Line keys

Each registered user is associated to a separate line key. Each line key displays the name of the registered account and some basic state information for that account.

The primary account is always associated to the first (bottom-right) line key of the IP Deskphone. If you are a secondary user, the order of the next available line key is from bottom to top and right to left on the IP Deskphone, followed by the keys on the Expansion Module from bottom to top and right to left. You can select a different available line key for secondary accounts during the login process

Pressing a line key either brings up a dialing prompt, initiates a call to a pre-selected target, or answers an incoming call.

At **Select Account** prompts (such as the Logout screen and User Settings screen), pressing a line key highlights the corresponding account.

Each line key reflects the state of its account.

- If there is a call for the account, a phone icon shows the state of the call whether it is on hold, or ringing.
- If there is more than one call, the state of the most active call is displayed. Missed incoming calls and new voice mail messages for the account are indicated with an icon. This supplements the **nn missed calls** message on the idle screen and the red LED, which cannot provide per-account information.

Do Not Disturb and Call Forwarding features also affect the appropriate line key icon of the account.

### Related links

[Multiuser](#) on page 169

---

## Making a call

You can place a call using any of the registered user accounts. The selected user account determines which proxy is used, which domain name is used for the call target if none was specified, who the target sees is calling, and what service package-dependent features are available.

The ways to initiate an outgoing call fall into two categories:

- always using the primary user's account
- using a different, explicitly-selected account. The usual way to select an alternate account is to press the line key of that account to obtain a dialing prompt.

If you initiate dialing by pressing digits from the Idle screen, the primary account is used after you lift the handset, press the headset key or press the handsfree key. The same applies if you initiate a call from the Inbox, Outbox, or Instant Messages screen.

Similarly, the primary account is used when a dial prompt is first obtained after you lift the handset, press the handset key, or press the headset key, and the call is initiated by pressing digits from the Idle screen or by pressing the **Send** context-sensitive soft key.

If you initiate a call by pressing a line key, the user account associated with that line key is used when the call is initiated.

If you initiate a call from the Address Book or Friends list, the account that is selected to display the list is the same account that establishes the call.

In all cases, if you initiate the call by pressing a line key, then the account associated with that particular line key takes precedence.

For example, pressing Line Key 1 to obtain a dial prompt, dialing, then pressing Line Key 2 initiates the call using the account associated with Line Key 2. However, there are cases where pressing a Line Key does not initiate dialing (for example, Address Book in Select mode).

While the outgoing call is ringing, the selected account is displayed on screen on a **From:** line.

### Related links

[Multiuser](#) on page 169

---

## Receiving a call

When you receive an incoming call, the displayed information shows which account the call is intended to reach. The line key of the corresponding account displays an **incoming call** icon. The call can be answered by:

- pressing the **Answer** context-sensitive soft key
- taking the handset off hook
- pressing the **Headset** or **Handsfree** key
- pressing the appropriate line key of the account

 **Note:**

You cannot use a different account to answer the call.

If the IP Deskphone receives multiple calls at the same time, a list (sorted by the most recent incoming call first) of all active and incoming calls appears. After you select a specific call in the list, you can either answer the call or process the call.

An **incoming-call** icon provides visual feedback. You can answer the call by pressing the line key directly without having to select the call. This automatically puts other active calls on hold.

### Related links

[Multiuser](#) on page 169

[Multiuser](#) on page 169

---

## Being in a call

When a single call is active, the screen displays the local account in use and the remote user. If multiple calls are active, each call appears on a single line. The local account for the active call appears on the context line. Each line key reflects the most active call state of its account.

The active call is affected by operations such as call transfer or call parking. One exception is the New Call action, which uses the primary account by default; this can be overridden by pressing another line key to initiate the call.

Joining calls into a specific conference always uses the conference server of the primary account. Accounts which cannot access the server cannot join the conference.

After you create an ad-hoc conference, you can join additional calls into the same conference. You cannot create more than one ad-hoc conference at a time.

Three-way calls can join any two calls, regardless of the account. The service package of the account to which a call is associated determines which operations (for example, Call Park) are available on that call. After you have established a 3-way call, the Join functionality becomes unavailable until the 3-way call is terminated.

### Related links

[Multiuser](#) on page 169

---

## Instant Messages

Only the primary account can send or receive instant messages. Incoming messages for secondary accounts are rejected; they are not displayed on screen, and are not added to the instant message logs.

### Related links

[Multiuser](#) on page 169

---

## Menu features

The IP Deskphone menu displays are customized to match the service package of the active account that is accessing the menu. In most cases, menus are accessed from the Idle screen and the primary account is active. For example, you can only use the **Retrve** context-sensitive soft key to retrieve a parked call if call parking is allowed by the service package of the primary account.

Similarly, accessing the Address Book, either through the corresponding hard key or through the **View** menu, usually displays the Address Book of the primary account. However, accessing the Address Book in select mode (for example, while dialing, or selecting an item for a speed dial key) accesses the address book of the latest user account used on the address-input screen.

### Related links

[Multiuser](#) on page 169

---

## Modifying settings

A number of preferences, in particular Voice Mail and IM settings, are per-account. The main **Preferences** menu includes a **User Settings** entry. Selecting this entry prompts you to select a registered account. After selecting an account, a menu appears that lets you modify the settings of that account.

### Related links

[Multiuser](#) on page 169

[Per-account call notification options](#) on page 177

[IM Settings](#) on page 177

[Voice Mail Settings](#) on page 177

[Remembering settings after logout](#) on page 177



---

## Per-account call notification options

The **Call Settings** entry in the **User Settings** menu provides a number of configuration options relating to how incoming calls for a particular account are treated:

- what kind of audio alert should be used (ring tone, beep, nothing)
- whether the red LED should blink
- whether the call should be added to the Incoming Calls log

### Related links

[Modifying settings](#) on page 176

---

## IM Settings

**IM Settings** is located under **User Settings**. Any change in settings on the primary account takes effect immediately. You can also modify settings for a secondary account, but they do not take effect until that account registers as the primary account.

### Related links

[Modifying settings](#) on page 176

---

## Voice Mail Settings

**Voice Mail Settings** is located under **Prefs > User Settings**. You can program different voice mail addresses and IDs for each account. To access the voice mail of a secondary account, press the line key of the secondary account to obtain a dial prompt, and then press the **VMail** context-sensitive soft key.

Waiting voice mail messages are reported in two ways:

- The red LED is lit if any account has a waiting message.
- A special icon (a shaded envelope) is displayed on the line key of each account with a waiting

message (unless the account is in a call). 

### Related links

[Modifying settings](#) on page 176

---

## Remembering settings after logout

For each profile, up to 24 sets of per-account settings are always remembered. If you have configured settings for an account, after the account is logged out, the settings are restored when the account is logged back in as either a primary or secondary account.

When an account is logged in without settings saved in the profile, a new set of default settings is created for it. If there are already 24 sets of per-account settings in the profile, one setting for which the account is not currently registered is discarded, and the new setting is saved.

### Related links

[Modifying settings](#) on page 176

---

## Programmable keys

A line key associated with a registered account cannot be used for programmable features. The **Program Key** screen lists all the line keys. All line keys associated with an account are displayed as such, and selecting them displays an error message.

The **Do Not Disturb**, **Call Forward**, and **Presence** keys are associated to a specific user account when they are created, and determine which account's status to affect. For more information see [User status](#) on page 179.

By default, you can press a **Speed Dial** programmed key to initiate a call using the primary account. If a line key is pressed to obtain a dialing prompt and then a speed dial key is pressed, the account of the line key is used. When accounts are registered on different domains, you can only program and use speed dial keys with targets that are reachable on the domain of the secondary account. It is possible to program and use speed dial keys with targets that are only reachable on the domain of a secondary account. The Speed Dial keys always uses the primary account to determine the presence state of the target.

Instant Message keys always use the primary account, because IM support is disabled for secondary accounts.

### Related links

[Multiuser](#) on page 169

[Inbox, Outbox, IM log](#) on page 178

---

## Inbox, Outbox, IM log

There is a single Inbox, a single Outbox and a single Instant Message log for each profile. The detailed view of the call log entry indicates the local account associated to each entry; that is, the source of outgoing calls and the target of received calls.

Call logs and IM logs provide many ways of initiating a call to the address identified by the selected entry, such as lifting the handset. In most cases, the primary account is used. However, if you press a line key to initiate the call, the call uses the account associated with the line key.

If call logs and IM logs are invoked in **Selection** mode; you cannot initiate a call directly. In this case, the **Select** soft key populates a dial prompt or other input field with the selected target. The operation already in progress determines which account to use. For example, if you press the line

key to obtain a dial prompt, press the **Inbox** key to select a target, press **Select**, then press **Send**, then the line key that was originally pressed determines the account.

#### Related links

[Programmable keys](#) on page 178

---

## Address books

Each profile contains a local address book, which is independent from all network address books.

Accessing the Address Book in **View** mode (by pressing the Directory hard key from the Idle screen) displays the address book of the primary account. If the primary account does not have a network address book, then the local address book is accessed.

Accessing the Address Book in **Selection** mode always accesses the address book of the current account. For example, after obtaining a dial prompt by pressing Line Key 2, pressing the Directory key accesses the address book of the account associated to Line Key 2. The network-based directory of the appropriate account is accessed only if it is available; otherwise, the local address book is used.

The network-based address book of secondary users can only be accessed in **Selection** mode. You cannot modify the address book of a secondary account on the IP Deskphone. However, modifications made remotely to the address book, such as using a different client or the Personal Agent, are reflected on the IP Deskphone. The local address book is shared by all accounts that do not have a network-based address book.

You can modify the local address book only if the primary account has no network-based address book. Changes to the network-based address book of the primary account are not reflected in the local address book.

The **Friends** view always accesses and modifies the address book of the primary account (local or network-based). There is no selection mode for the Friends view. You can only monitor and view the presence information of Friends of the primary account in Friends view.

#### Related links

[Multiuser](#) on page 169

---

## User status

This section describes the features associated with the User status.

#### Related links

[Multiuser](#) on page 169

[Do Not Disturb](#) on page 180

[Presence](#) on page 180

[Call Forwarding](#) on page 181

---

## Do Not Disturb

Selecting the **Do Not Disturb** command from the **Services** menu prompts you to specify which account should be placed in DND mode. The option **all** allows you to place all accounts in DND mode. Selecting an option requests you to confirm the operation before proceeding. The option **all** is highlighted by default.

Activating DND for a specific account automatically causes calls to that account to be rejected with a busy indication; however, calls to other accounts can be received. When DND mode is active for an account, the line key of the particular account periodically displays a DND indicator on its label.

The following scenarios apply to DND:

- If you select a single account and the account is already in DND mode, then you are asked if you want to disable DND rather than asked if you want to enable DND.
- If you select a single account and the account has Call Forwarding active, then an error message appears indicating that DND cannot be activated.
- If you select the option **all** and if at least one account is not in DND mode, then the DND mode is activated for all accounts. If any account is in Call Forward mode, Call Forward is disabled.
- If you select the option **all** when all accounts are in DND mode, DND mode is deactivated for all accounts.

When using a programmed DND feature key, the account that is impacted by the DND feature key is determined when the feature key is configured. When the DND feature key is pressed, the DND feature behavior is the same as previously described, except no confirmation prompt is displayed. The operation is performed immediately, and a message indicating what was done is displayed.

DND mode for each account is persistent. If you restart the IP Deskphone, or log out and log in, the account maintains the original state.

### Related links

[User status](#) on page 179

---

## Presence

Users have two ways to change their presence state:

- The first way allows the user to select the desired state from a list of predefined states or to create a new state (only in model v6) by pressing the **Presence** soft key.
- The second way is based on using programmable feature keys. The user can configure line keys that are used to quickly switch into the desired presence state. These keys can be configured for certain user account or for all accounts at once that are registered on the phone.

Selecting the **Presence** soft key prompts you to specify which presence state of the user account should be modified. The option "All" lets you configure all registered user accounts to the same

presence in one operation. If you select a single account, then the current state of the account is displayed and you are prompted whether it should be changed. You are then prompted to enter the new presence state. The new presence state is applied after it is confirmed.

If the "All" option is selected, no current state is displayed, and you are immediately prompted to select the new state. The new state is then applied to all registered accounts. Line keys can be configured to change the presence state of a single user account or of all registered user accounts. This is specified at the configuration stage. When a line key configured for a single account is pressed, the phone can act in two different ways depending on the current state of the user:

- If the account is already in the desired state, the account is configured to the "Connected" (v6) or "Available" (v7) presence state.
- If the account is not in the desired state yet, the account is configured to the programmed presence state defined by the pressed line key.

When the line key configured for all registered accounts is pressed, all accounts are set to this presence state.

As with Call Forwarding keys, this allows Presence keys to be used as toggles for a single account. However, in model v6 there are several states which are published automatically when corresponding event occurs. For example, the state "On the Phone" is published in case the user makes a call and their current phone state is "Connected". The state "On hook" is published when call is finished and only if phone state is "Connected".

All states are applied by sending a message to the SIP proxy, which can choose not to accept the change. As a result, it is possible for a "Set All" presence operation to not result in all accounts being configured to the programmed presence. In such a case, pressing the key again would again attempt to apply the programmed presence. Therefore it is more effective to program a separate **Presence** key to configure all accounts to the Connected state. Events that update presence states automatically occur on a per-account basis. For example, the "On The Phone" state is applied to any account for which at least one call is active.

Account presence is not retained after logging out or rebooting.

### Related links

[User status](#) on page 179

---

## Call Forwarding

Selecting the **Call Forward** command from the **Services** menu prompts you to specify which account must be placed in Call Forward mode. The following is an example of the Call Forward menu:

1. *All accounts*
2. *Disable for all accounts*
3. *mary@abc.com*
4. *bob@abc.com*
5. *alex@abc.com*

The option **All accounts** places all accounts in Call Forward mode in one operation and the option **Disable for all accounts** deactivates Call Forward for all accounts at once.

The following scenarios apply to Call Forward:

- If you activate Call Forward for a specific account, then all calls to the selected account are redirected automatically to the specified address. The target address of the account must be reachable from the domain. Calls to other accounts are still received. The line key label periodically indicates that Call Forward mode is active.
- If you select a single account with neither Call Forward nor DND active, then you are prompted to specify a forwarding target. Call Forward is then enabled. If DND is already active, a message indicating

`Call Forward cannot be activated`

displays. If Call Forward mode is already active, then you are prompted whether to deactivate it.

- If you select the **All accounts** option, then all accounts are configured in Call Forward mode using the provided target. DND mode is deactivated for all accounts. If the accounts are already in Call Forward mode for a different target, they are updated to use the new target.
- If you select the **Disable for all accounts** option, the Call Forward feature is deactivated for all accounts for which it is currently active.

When a single user account is selected:

- If the account is already forwarding calls to the programmed target, call forwarding is deactivated.
- If call forwarding is not already activated, then the account is configured to forward calls to the given target, disabling DND if necessary, and overriding any other call forward target that might be active for the account.

For both a single key and the **All accounts** key, you can treat the key as a toggle. If no Call Forward or DND operations are selected, pressing the key switches one or all accounts between forwarding to the key's target and not forwarding states.

The Call Forward state and target for each account is persistent. If you restart the IP Deskphone or logout and login, the Call Forward state is retained.

### Related links

[User status](#) on page 179

---

## Notifications

The system displays messages spontaneously on the IP Deskphone screen to report events that are not initiated by you. This includes such events as failure to retrieve a service package and availability of a new Location list.

These spontaneous notifications do not indicate which account is affected by the event. In such cases, the affected account is indicated by the message itself.

It is possible for the same event to occur for multiple accounts at the same time. In this case, they are displayed one after the other.

#### Related links

[Multiuser](#) on page 169

---

## Account selection

There are a number of scenarios where you are prompted to select an account (for example, logout, per-account settings, programming keys). These scenarios fall into two categories:

1. Prompts where exactly one account must be selected
2. Prompts where an “all” or “none” option is available

In the first case, if you have logged in only one account, then the prompt is not displayed. The single account is selected automatically, and the next screen is immediately displayed. Otherwise, the primary account is always at the top of the list, and is highlighted when the prompt is first displayed. In all cases, pressing the line key of an account highlights the corresponding item in the account list. If no selection is made in a certain amount of time, then the operation is cancelled.

#### Related links

[Multiuser](#) on page 169

---

## Receiving a call

When you receive an incoming call, the displayed information shows which account the call is intended to reach. The line key of the corresponding account displays an **incoming call** icon. The call can be answered by:

- pressing the **Answer** context-sensitive soft key
- taking the handset off hook
- pressing the **Headset** or **Handsfree** key
- pressing the appropriate line key of the account

#### **Note:**

You cannot use a different account to answer the call.

If the IP Deskphone receives multiple calls at the same time, a list (sorted by the most recent incoming call first) of all active and incoming calls appears. After you select a specific call in the list, you can either answer the call or process the call.

## Multiuser

An **incoming-call** icon provides visual feedback. You can answer the call by pressing the line key directly without having to select the call. This automatically puts other active calls on hold.

### Related links

[Multiuser](#) on page 169

[Multiuser](#) on page 169



# Index

## Numerics

3-way calling ..... [118](#)

## A

Abbreviated Dialing Lists ..... [166](#)  
Accessing Instant Messages ..... [108](#)  
Accessing the calls in your Call Inbox during a call ..... [101](#)  
Accessing the calls in your Call Outbox during a call ..... [104](#)  
Accessing the Services menu ..... [145](#)  
Account selection, multiuser ..... [183](#)  
add a new contact to your Address Book ..... [159](#)  
Add a new group to Address Book ..... [160](#)  
Adding a contact to Address Book ..... [89](#)  
Adding a new Presence state message ..... [139](#)  
Additional logins, multiuser ..... [170](#)  
Address Book, add a new contact ..... [159](#)  
Address Book, adding a contact to ..... [89](#)  
Address Book, call from the ..... [88](#)  
Address Book, copying information to ..... [91](#)  
Address Book, editing a contact in ..... [90](#)  
Address Book, viewing ..... [88](#)  
Address Book, view the existing groups ..... [158](#)  
Address books, multiuser ..... [179](#)  
Ad hoc conferencing when connecting to the Call Server ..... [119](#)  
Advanced features ..... [144](#)  
animated slideshow ..... [152](#)  
Audio Codec Ordering ..... [141](#)  
Audio Codecs ..... [140](#)  
Audio Codec Selection ..... [140](#)  
Automatic login, multiuser ..... [170](#)  
Automatic remote software updates ..... [142](#)  
Autoprogram feature keys ..... [131](#)  
Auto-Retrieve flag ..... [162](#)

## B

Background image ..... [155](#)  
Being in a call, multiuser ..... [175](#)  
Bulk, Remove all programmed feature keys by using the Bulk context-sensitive soft key ..... [131](#)  
Bulk, Remove individual programmed feature keys by using the Bulk context-sensitive soft key ..... [131](#)  
Bulk-create feature keys based on an existing directory Address Book group ..... [157](#)  
Busy Lamp Field feature ..... [142](#)

## C

Cable unplugged, multiuser ..... [172](#)  
Call, using the active call context-sensitive soft key menu ..... [113](#)

Call Forward, activate ..... [134](#)  
Call Forward, deactivate ..... [134](#)  
Call Forward, using ..... [134](#)  
Call Forwarding, multiuser ..... [181](#)  
Call Forward reminder signal ..... [134](#)  
call from the Address Book ..... [88](#)  
Call Inbox ..... [96](#)  
Call Inbox, Accessing the calls during a call ..... [101](#)  
Call Inbox, deleting calls ..... [101](#)  
Call notification options, multiuser ..... [177](#)  
Call notification options, per-account, multiuser ..... [177](#)  
Call Outbox ..... [96](#), [102](#)  
Call Outbox, accessing the calls during a call ..... [104](#)  
Call Outbox, deleting calls from ..... [103](#)  
Call Outbox, initiating a call from ..... [103](#)  
Call Outbox, managing calls while not on a call ..... [102](#)  
Call Outbox, Viewing the details of a call in ..... [104](#)  
Call Park and Speed Dial keys ..... [121](#)  
Call state icons, display screen — Quick reference ..... [31](#)  
Call Subject, adding ..... [82](#)  
Call Subject, deleting ..... [83](#)  
Call Subject, editing ..... [83](#)  
Call Subjects, managing ..... [82](#)  
Call Subjects, using ..... [81](#)  
Call Waiting ..... [114](#)  
Change Class of Restriction ..... [167](#)  
Change Coverage ..... [167](#)  
Checking for software updates ..... [146](#)  
Checking for updates ..... [146](#)  
Class of Restriction, change ..... [167](#)  
Codec, selection ..... [140](#)  
Codec order ..... [141](#)  
Codecs, audio ..... [140](#)  
Composing an Instant Message ..... [107](#)  
Conferencing, ad hoc ..... [119](#)  
Configuring a Presence state ..... [137](#)  
Configuring Do Not Disturb ..... [136](#)  
Configuring IM audible alert ..... [106](#)  
Configuring IM automatic pop-up ..... [105](#)  
Configuring Instant Messaging ..... [105](#)  
Configuring Instant Messaging pop-ups ..... [106](#)  
Configuring the Avaya 1165E IP Deskphone ..... [59](#)  
Confirmation logon screen ..... [56](#)  
Copy an image file from the USB drive into the IP Deskphone ..... [165](#)  
Copying information to the Address Book ..... [91](#)  
Copy key, creating a feature key using ..... [133](#)  
Copy the ring tone from the IP Deskphone to the USB drive ..... [165](#)  
Creating a feature key using the Copy key ..... [133](#)  
Customizable banner for login ..... [151](#)

**D**

Deactivate Call Forward .....	<a href="#">134</a>
delete a user profile .....	<a href="#">147</a>
Delete Friend information .....	<a href="#">124</a>
delete user data files: .....	<a href="#">147</a>
Deleting an Instant Message .....	<a href="#">110</a>
Deleting calls from your Call Outbox .....	<a href="#">103</a>
Deleting calls in your Call Inbox .....	<a href="#">101</a>
Display screen icons, Quick reference .....	<a href="#">31</a>
Do Not Disturb, configuring .....	<a href="#">136</a>
Do Not Disturb, disable .....	<a href="#">136</a>
Do Not Disturb, enable .....	<a href="#">136</a>
Do Not Disturb, multiuser .....	<a href="#">180</a>

**E**

EC500 Self Administration .....	<a href="#">167</a>
Editing a contact in Address Book .....	<a href="#">90</a>
Editing information of a friend .....	<a href="#">124</a>
Erasing the user data .....	<a href="#">147</a>

**F**

FAC .....	<a href="#">111</a>
Failed to login user, Authentication required .....	<a href="#">56</a>
Feature key, remove programmed key .....	<a href="#">130</a>
Feature key autoprogramming .....	<a href="#">131</a>
Feature key programming .....	<a href="#">125</a>
Feature keys .....	<a href="#">125</a>
File manager .....	<a href="#">162</a>
File Manager .....	<a href="#">164</a>
File Manager, using .....	<a href="#">165</a>
Flash drive .....	<a href="#">150</a>
FNE .....	<a href="#">111</a>
Friend, deleting information .....	<a href="#">124</a>
Friend, editing information .....	<a href="#">124</a>
Friends feature .....	<a href="#">122</a>
Friends list .....	<a href="#">123</a>

**G**

Goodbye/Release key .....	<a href="#">20</a>
Group, add a new group .....	<a href="#">160</a>
Group Call Pickup .....	<a href="#">112</a> , <a href="#">143</a>
Group Support .....	<a href="#">156</a>

**H**

handsfree calling .....	<a href="#">80</a>
Handsfree key .....	<a href="#">20</a>
Headset key .....	<a href="#">20</a>
Hold .....	<a href="#">114</a>
Hold, access a call on hold when multiple calls are on hold: .....	<a href="#">115</a>
Hold, make a call on hold the active cal .....	<a href="#">115</a>

Hold, Multiple calls on .....	<a href="#">115</a>
Hold key .....	<a href="#">20</a>
hookswitch .....	<a href="#">20</a>

**I**

Icons, Call state — Quick reference .....	<a href="#">31</a>
Icons, display screen — Quick reference .....	<a href="#">31</a>
Icons, Inbox — Quick reference .....	<a href="#">31</a>
Icons, Instant messaging — Quick reference .....	<a href="#">31</a>
Icons, presence — Quick reference .....	<a href="#">31</a>
Ignore an incoming call .....	<a href="#">86</a>
Images, background .....	<a href="#">155</a>
Image screen, selecting .....	<a href="#">155</a>
IM audible alert, configuring .....	<a href="#">106</a>
IM automatic pop-up, configuring .....	<a href="#">105</a>
IM Settings, multiuser .....	<a href="#">177</a>
Inbox, Outbox, IM log, multiuser .....	<a href="#">178</a>
Inbox icons, — Quick reference .....	<a href="#">31</a>
incoming call, ignore .....	<a href="#">86</a>
incoming call, redirecting .....	<a href="#">85</a>
Initial login, multiuser .....	<a href="#">169</a>
Initiating a call from an Instant Message .....	<a href="#">109</a>
Initiating a call from the Call Outbox .....	<a href="#">103</a>
Initiating a call using the active call context-sensitive soft key menu .....	<a href="#">113</a>
Instant Message, composing .....	<a href="#">107</a>
Instant Message, deleting .....	<a href="#">110</a>
Instant Message, initiating a call from .....	<a href="#">109</a>
Instant Message, replying to .....	<a href="#">109</a>
Instant Message, viewing the content of .....	<a href="#">109</a>
Instant Message automatic pop-ups .....	<a href="#">105</a>
Instant Message Inbox/Outbox .....	<a href="#">107</a>
Instant Messages, accessing .....	<a href="#">108</a>
Instant Messages, multiuser .....	<a href="#">176</a>
Instant Messaging .....	<a href="#">105</a>
Instant Messaging, configuring .....	<a href="#">105</a>
Instant messaging icons, — Quick reference .....	<a href="#">31</a>
Instant Messaging pop-ups, configuring .....	<a href="#">106</a>
IP Deskphone information, viewing .....	<a href="#">144</a>

**K**

Key press behavior .....	<a href="#">20</a>
--------------------------	--------------------

**L**

Line key .....	<a href="#">20</a>
Line keys, multiuser .....	<a href="#">173</a>
Location information .....	<a href="#">58</a>
Logging off from the IP Deskphone .....	<a href="#">57</a>
Logging out, multiuser .....	<a href="#">171</a>
logon confirmation .....	<a href="#">56</a>
logon error messages .....	<a href="#">56</a>
logout, secondary account .....	<a href="#">171</a>

**M**

Making a call	78
Making a call, multiuser	174
Making a call using off-hook dialing	78
Making a new call	112
Managing calls in the Call Outbox while not on a call	102
Menu features, multiuser	176
Message Waiting Indicator	33
missed calls	99
Modifying settings, multiuser	176
Multiple calls On Hold	115
Multiuser	169
Multiuser, account selection	183
Multiuser, additional logins	170
Multiuser, Address books	179
Multiuser, automatic login	170
Multiuser, being in a call	175
Multiuser, cable unplugged	172
Multiuser, Call Forwarding	181
Multiuser, Do Not Disturb	180
Multiuser, IM Settings	177
Multiuser, Inbox, Outbox, IM log	178
Multiuser, initial login	169
Multiuser, Instant Messages	176
Multiuser, line keys	173
Multiuser, logging out	171
Multiuser, making a call	174
Multiuser, menu features	176
Multiuser, modifying settings	176
Multiuser, notifications	182
Multiuser, per-account call notification options	177
Multiuser, Presence	180
Multiuser, primary account logout	171
Multiuser, programmable keys	178
Multiuser, receiving a call	175, 183
Multiuser, remembering settings after logout	177
Multiuser, secondary account logout	171
Multiuser, upgrade impacts to user profiles	172
Multiuser, user status	179
Multiuser, Voice Mail Settings	177
Mute key	20

**N**

Network menu	149
New call, making	112
Notifications, multiuser	182

**O**

Overwriting your personal Address Book	56
--	----

**P**

park a call using Speed Dial	121
------------------------------	-----

Park Call	121
Password protection for domains	51
PC Client softphone interworking with the IP Deskphone	141
Per-account call notification options, multiuser	177
Phone Information - Details screen	151
Placing a call on Hold	114
Presence, multiuser	180
Presence icons, — Quick reference	31
Presence state, configuring	137
Presence state messages, adding new	139
Primary account logout, Multiuser	171
Programmable keys, multiuser	178
Programmed feature key, remove	130

**R**

Receiving a call	84
Receiving a call, multiuser	175, 183
reconnecting, with multiple logins	171
Redirecting an incoming call	85
Remembering settings after logout. multiuser	177
Remote software updates	142
Remove all programmed feature keys by using the Bulk context-sensitive soft key	131
Remove a programmed feature key	130
Remove individual programmed feature keys by using the Bulk context-sensitive soft key	131
Replying to an Instant Message	109
Resetting the IP Deskphone	146
Retrieve a parked call	121
retrieve a parked call to a different phone	121
retrieve a parked call to the same phone	121
retrieve a parked call using Speed Dial	121
Ring tone, Copying the ring tone from the IP Deskphone to the USB drive	165
Root screen	162

**S**

Screensaver/screen lock	152
Secondary account logout, multiuser	171
Select Device screen	162
Selecting a location	55
Selecting an image screen	155
Select User screen	171
Server failover, multiuser	171
Service Package Group Support	156
Services, menu, accessing	145
slideshow, animated	152
Software updates, checking for	146
speed dial for FACs and FNEs	111
Speed Dial List	160
Speed Dial List screen	161
Station Lock and Unlock	168

## Index

### T

Timed logoff while on a call .....	<a href="#">54</a>
Transferring a call .....	<a href="#">120</a>

### U

Updates, checking for .....	<a href="#">146</a>
Upgrade impacts to user profiles, multiuser .....	<a href="#">172</a>
USB flash drive .....	<a href="#">150</a>
USB flash memory device support .....	<a href="#">162</a>
USB scenarios .....	<a href="#">165</a>
User data, erasing .....	<a href="#">147</a>
User status, multiuser .....	<a href="#">179</a>
Using 3-way calling .....	<a href="#">118</a>
Using Call Forward .....	<a href="#">134</a>
Using the Friends feature .....	<a href="#">122</a>

### V

View existing groups in your Address Book .....	<a href="#">158</a>
View existing groups in your Address Book if you selected Groups .....	<a href="#">158</a>
Viewing the Address Book .....	<a href="#">88</a>
Viewing the content of an Instant Message .....	<a href="#">109</a>
Viewing the details of a call in the Call Outbox .....	<a href="#">104</a>
Viewing the IP Deskphone information .....	<a href="#">144</a>
View the existing groups in your Address Book .....	<a href="#">158</a>
Visual Alerter .....	<a href="#">33</a>
Voice Mail Settings, multiuser .....	<a href="#">177</a>

### W

While on an active call .....	<a href="#">111</a>
-------------------------------	---------------------