

LITHEAUDIO[®]

WIRELESS MICRO SUB WOOFER

INSTRUCTION MANUAL

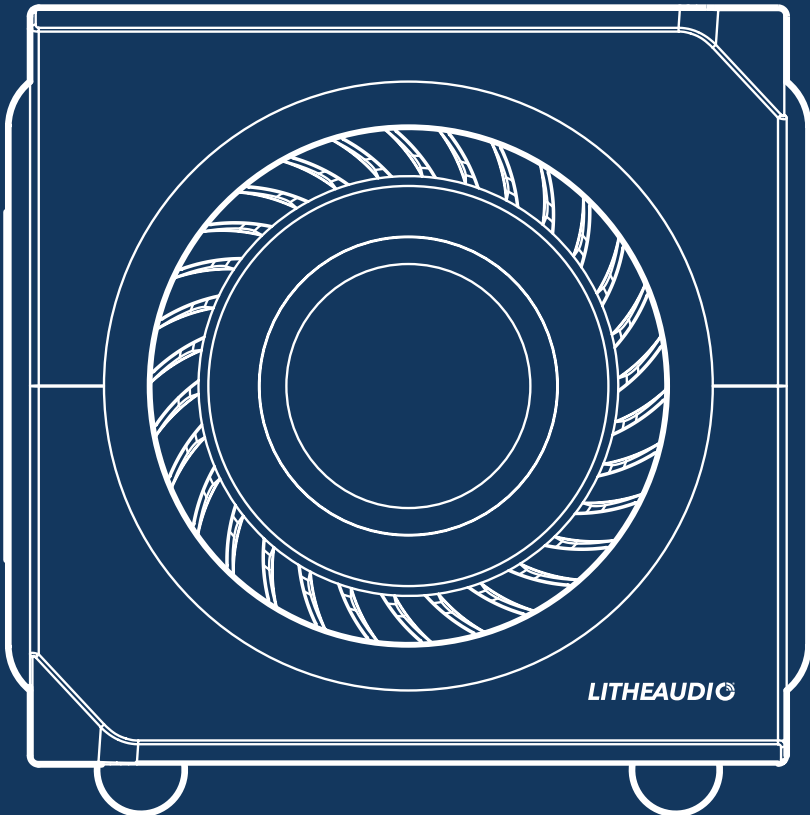

IMPORTANT SAFETY WARNING

BEFORE USE PLEASE READ COMPLETELY AND USE THE PRODUCT IN ACCORDANCE WITH THESE SAFETY INSTRUCTIONS.

READ THE INSTRUCTIONS CAREFULLY BEFORE STARTING THE INSTALLATION PROCESS AND KEEP THEM SAFE FOR FUTURE REFERENCE.

FAILURE TO FOLLOW THE SAFETY INSTRUCTIONS COULD RESULT IN FIRE, ELECTRIC SHOCK, OR OTHER INJURY OR DAMAGE.

- Failure to follow the instructions in this guide voids all warranties on your speakers.
- Warning: To reduce the risk of fire and electric shock. Do not use the product in water or expose the product or power cable to liquids. If your cable /product gets wet, Turn off the power at the mains switch.
- Warning: Do not install product directly above any heat sources such as radiators, or other apparatus that produce heat.
- Warning: To reduce the risk of fire or electric shock, do not expose this product to rain or moisture (directly above bath or shower area) or in Bathroom Zone 0 or Zone 1.
- Warning: Do not cover the product with items/obstructions that shall restrict ventilation, such as magazines, newspapers, clothes, blankets, curtains etc
- Warning: To reduce the risk of fire. Do not place the product on soft support such as bedding, sofas, blankets, etc.
- Warning: To avoid risk of electric shock, do not touch the product or connected any cables to the product during a lightning storm
- Ensure the product
- Protect the power cable from being damaged, do not over stretch cable.
- Only use attachments/accessories specified by the manufacturer Lithe Audio.
- Turn off the power to the speaker when unused for long periods of time.
- Do not open the back cover to the speaker as this protects the PCB as this will invalidate the warranty and could cause electric shock.
- Do not expose the product to extreme heat or cold temperatures, ensure the product is used within the operating temperatures set in this manual.
- This product does not have a on/off button. If required, to turn off the product, unplug the power cable from the wall socket, otherwise the product shall go into standby mode.

KNOW YOUR SUB

The Lithe Audio Sub Woofer works the Lithe Audio Wifi range of / products and any AirPlay 2 or Google Cast speakers.

4" 1x Active and 2x Passive drivers

Built in Amplifier & Wi-Fi chipset

Vibration free feet

Power input 24V/2.5A

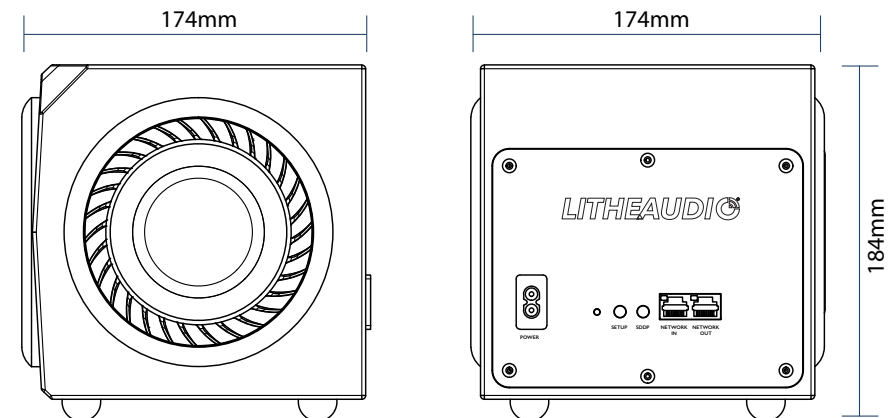
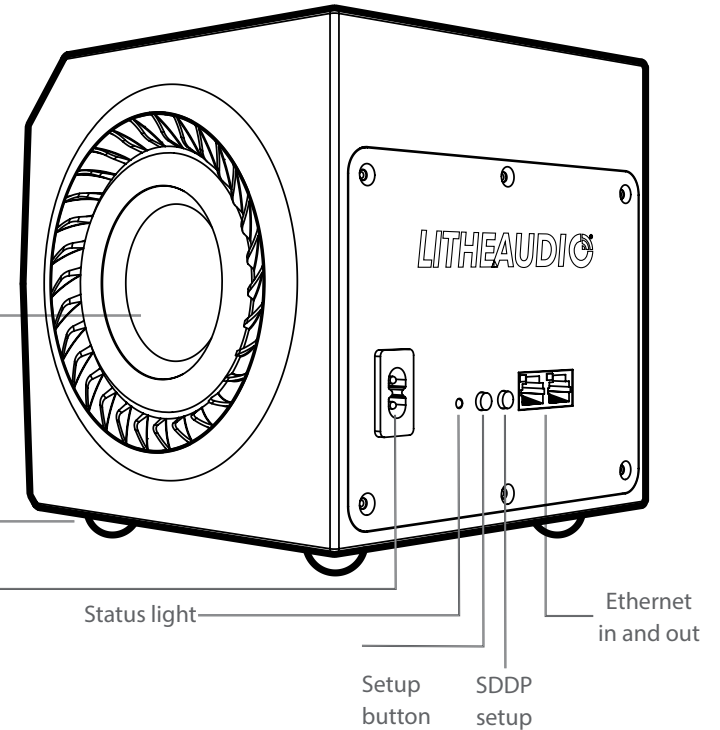

WHERE TO PLACE THE SUB

SPEAKER LOCATION

For optimal performance we recommend placing the micro sub woofer on the floor in the corner of the room in the vicinity of the ceiling speakers.

Placing the Micro Subwoofer in the corner of a room can increase the overall bass output, making the subwoofer sound louder. If this is not possible, ensure the subwoofer is not too far away from your optimal listening zone to maximise your listening experience. There is no right or wrong, move the subwoofer to a position that sounds right to your personal taste, keeping in mind the cable distance from the plug socket.

Use the lithe Audio App to tweak your listening experience further to change Low pass Filter, Phase, cross over and gain. With preset profiles according to your music taste.

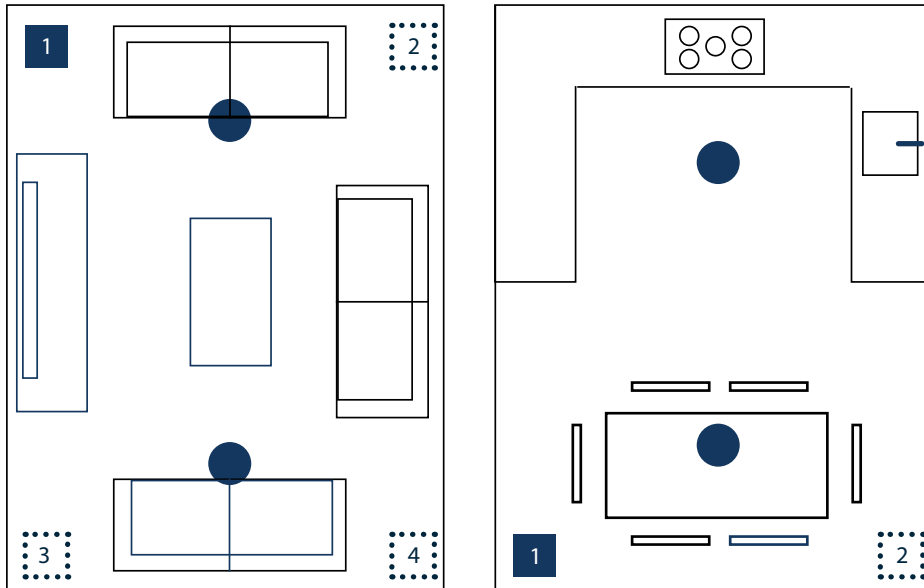

PLUG IN YOUR MICRO SUB

Plug your Micro Sub Woofer into a plug socket using the supplied power cable.

1. Plug the figure eight end of the power cable into the back as shown below first, whilst holding the product firmly, push the connector end into the back of the speaker until in place.

2. Connect the plug end into the plug socket and switch on plug socket (UK only). A solid Red light indicating the product is booting up, Green light shall start flashing indicating ready to connect.

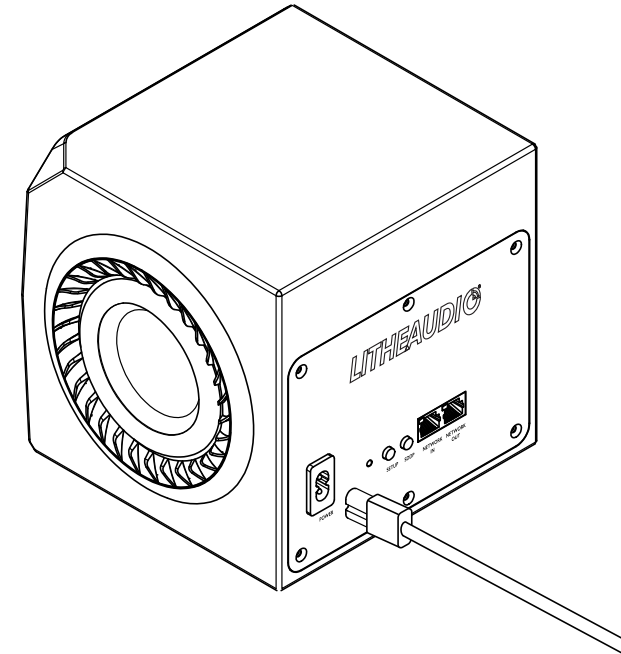

STATUS INDICATOR LIGHT

Located on the front face of the speaker, the LED Indicates the status of your speaker:

- Red solid: Speaker booting up
- Red quick flash (1s 4 times): Speaker under restart operation
- Red slow flash (3s 1 time): Speaker under standby mode, waiting for user operation
- Green solid: Speaker is active and connected to Wi-Fi
- Green slow flash(1s 1 time): Speaker trying to connect to the preconfigured Wi-Fi
- Green quick flash(1s 4 times): Speaker in WAC/SAC mode, user to configure Wi-Fi

YOUR HOME WI-FI NETWORK

To enable the Lithe Audio Wi-Fi ceiling speakers, your device must be on the same network.

- Ensure your network has a high speed internet connection, as the speakers are designed to provide you with free online software/firmware updates.
- High speed DSL / cable modem, or fiber to the home broadband is recommended for best possible playback of music services.
- Lithe Audio communicates over a 2.4GHz & 5GHz Wi-Fi home network supporting 802.11 b/g/n wireless technology only.
- For larger homes where Wi-Fi signal is not stable, we suggest adding access points/mesh network to strengthen the network or updating your router to a higher specification model to suit the demand OR connect via hard wired ethernet connection.
- For connections to computer or NAS drive for playing personal music library, we recommend for best performance connecting via Ethernet cable.
-

LITHE AUDIO APP

- To enhance your listening experience download Lithe Audio app via the app store on your device follow the setup procedures within this instruction manual.
- The app will allow you to setup singular rooms, groups of speakers or play in Party Mode.
- You can connect up to 30 speakers simultaneously and control them all from the app.

ETHERNET CONNECTION

To connect the speaker via ethernet cable use either of the RJ45 ports provided

The Micro Sub Woofer gives you the ability to daisy chain ethernet connections, reducing cable runs, saving time and money. Each speaker shall have its own IP address.

Connect one end of the RJ45 ethernet cable into an WiFi router or Port Gigabit switch, then run the other end of the RJ45 ethernet cable as required to the back of the speaker as shown into either port.

Once connected you shall see the ethernet port flashing red/green indicating the connection is active.

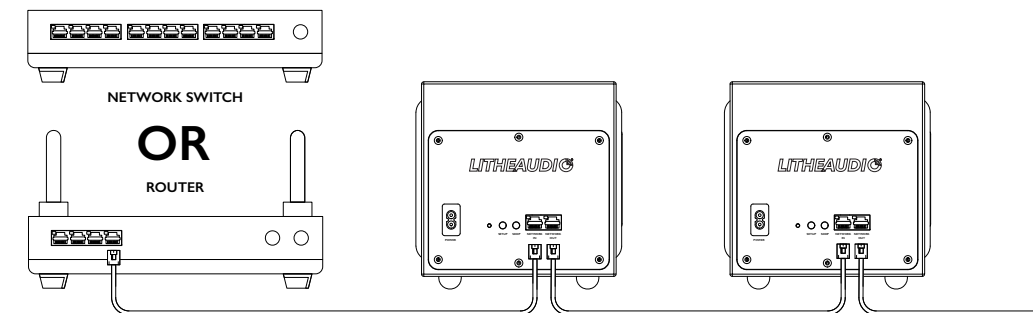

SDDP SETUP

If using the Sub with Control 4 home automation system, press the SDDP button to make the Sub discoverable for config.

SETUP FOR APPLE IOS

Download on the
App Store

OPEN CAMERA & SCAN TO
DOWNLOAD THE APP



NOTE: If you are connecting via ethernet cable no setup is necessary

1. Ensure the Wi-Fi speaker is connected to the power supply and is turned on, the LED indicator will flash red slowly.

2. Press and hold the 'Setup Button' for 5 seconds & release, the LED indicator will flash Green and the speaker is now ready to connect to your Wi-Fi network.

3. Open the Wi-Fi setting menu on your phone or tablet



4. Select the new Airplay speaker listed you would like to add to your network



5. Select your network and change the 'Speaker Name' to something easily identifiable e.g. Kitchen and click Next



4. The Lithe Audio Wi-Fi speaker setup is now complete, return to the Lithe Audio app



USING WITH AirPlay 2



To play directly to speaker(s) using a iOS devices (iPad, iMac, iPhone, Apple TV etc) you can connect via AirPlay 2. Please follow the steps below:

ENSURE THE SPEAKER IS CONNECTED TO THE POWER SUPPLY, AND THE WIFI NETWORK.

Note: When using AirPlay 2 the Lithe app grouping and playback functions for multiple speakers becomes redundant. The ability to play any source is now possible. As well as playing with other brands in a multi room environment.

1. Swipe down from the top right of the screen



2. Click on the right corner icon to show available AirPlay devices



3. Audio display screen shall show available devices to play music through as per list



4. Select the speaker(s) to play music through open any app and play your music



SETUP FOR GOOGLE HOME

1. Download the Google Home app from the Google Play store
2. Ensure the Wi-Fi speaker is connected to the power supply and is turned on, the LED indicator will flash red slowly.
3. Press the + top left hand corner, Click set up device, choose home to start looking for devices on your network, choose Speaker, Next.

4. Open Google Home and click the + sign top left hand corner



5. Click set up device, New devices Setup new device



6. Select existing home or create new home to start looking for devices



7. Select speaker, Next, click on Lithe Audio Speaker all set.



Using with Chromecast



To play directly to speaker(s) using Google Cast. Please follow the steps below:

ENSURE THE SPEAKER IS CONNECTED TO THE POWER SUPPLY, AND THE WIFI NETWORK.

Note: When using Google Cast the Lithe app grouping and playback functions for multiple speakers becomes redundant. The ability to play any source is now possible. As well as playing with other brands with Google Cast built in within a multi room environment.

1. To group speakers, click +, create speaker group



2. Click on the speakers you want to group, next, name group

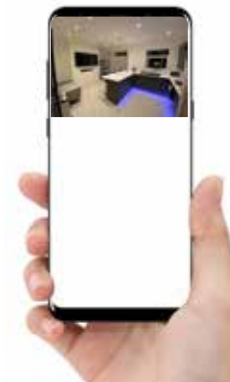

3. Audio display screen shall show available devices to play music through as per list



4. Select the speaker to play music through and press play on your source player



EQ SETTING

To tune the Micro Sub Woofer, your device must be on the same network.

Download the Lithe Audio App, with speaker settings adjust the equaliser settings as below:

LOW PASS FILTER

The low-pass filter eliminates the notes you don't want your subwoofer to play, leaving the bass and the low drums.

PHASE

This is used to match the subwoofer audio output to the main speakers. Set the subwoofer to be either 0 or 180 degrees.

GAIN

Gain control enables you to blend the bass levels with the output of other speakers within the system to achieve optimal sound quality.

CROSS OVER

The cross over frequency of the micro subwoofer is the frequency at which your speakers tail off and your subwoofer kicks in with the bass. The most common frequency range for crossover is 80Hz

Within the app there are various listening profile presets for common listening tastes, select one of these if you are unsure of the detailed settings needed. We have done this for you, all you have to do is set the volume, listen and relax.



SPEAKER

- Sound Quality THD+N < 0.009%, 40Hz-200Hz @ -10dB
- RMS Power: 50W RMS @ 4 Ohm load
- Sensitivity (1W/1m): 90dB
- Type: Class D (Digital)
- Audio Compression: 192KHz/24bits
- Bluetooth 4.1
- Woofer: 4" Polypropylene Driver / 2 x 4" Passive radiator

MUSIC ACCESS

- Audio Formats Supported: MP3, WMA, AAC (MPEG4), AAC+, ALAC, FLAC, APE, WAV, OGG, LPCM
- Audio Sample Rate: up to 192kHz 24bit
- Music Services Supported by Lithe Audio include; Airable Radio, Podcast, Tidal, Deezer, Soundmachine, Amazon Music, Napster, Spotify, etc..
- Operating Systems (for stored files) Windows XP SP3 and higher; Mac OS X 10.6.8 and higher; NAS (network-attached storage) devices supporting CIFS

MULTI ROOM

- Expandable up to 30 speakers within same Wi-Fi network

WIRELESS NETWORKING

- Wi-Fi Connectivity: Wi-Fi CERTIFIED™ 802.11 a, b, g, n, ac WPA™ - Personal WPA2™ - Personal WMM®, Wi-Fi Protected Setup™
- Wireless connectivity works on your home Wi-Fi network with both 2.4GHz/5GHz broadcast routers
- Internet connection required for access to Internet radio stations, online music services and software updates.

GENERAL

- Internal Power Supply : 100 - 240V,

- 50/60Hz / 3A
- Output Supply : DC24V / 3A >5mins
- DC24V / 5A Peak power >10s
- Dimensions (W x D) 174 x 174 mm (6.85 x 6.85 in)
- Weight 3kg (6.61 lbs)
- Operating Temperature 0° to 40° C (32° to 104° F)
- Storage Temperature -20° to 70° C (4° to 158° F)
- Standby power: 1.3W / 0.02A
- Connected power: 1.5W / 0.03A
- Playing Music: 2.8W - 10.5W / 0.03A - 0.09A**

* Specifications subject to change without notice.

** Power Consumption depends on the type of music & volume - Increased Bass & volume requires more power loading on the amplifier.

- Internet functionality may require payment of separate fee to a service provider.

SPOTIFY CONNECT



You will need to have the Spotify Premium account, the latest spotify app installed and be connected to the same Wi-Fi network to play via Spotify connect directly.

Open Spotify app, on your phone, tablet or laptop.

Play a song and select DEVICES AVAILABLE at bottom of player page
Select your device and start listening to your spotify music

NOTE: If your connection to speaker is lost, the device may have weak Wi-Fi signal. Please visit: <https://www.spotify.com>

TROUBLESHOOTING

If a problem arises, please try the troubleshooting guide below. If the problem is not listed please contact Lithe Audio Customer Service Support

Q: Speaker has not been found during setup

A: Please check power cord is correctly connected into speaker and transformer, Check the red light is ON. Press reset button for 5 seconds on the speaker (discoverable mode), green light shall flash, follow the instructions for Android or AirPlay 2 setup.

Q: Speaker connected to AirPlay 2 but not playing through device

A: Please ensure device has good Wi-Fi strength and battery power, check the led indicator is solid green, if not press reset button for 3 secs. Failing this, turn the speaker power off then on.

Q: Device is connected to Wi-Fi speaker but no sound

A: Ensure your device volume is NOT muted, increase the volume within app and try again. Restart the app which the audio is playing from and try again.

Q: Lithe Audio App not showing connected speakers

A: Ensure your speakers green light are on, and connected as per setup. The app shall automatically find active speakers, if not, restart app or press reset on speaker for 3 secs to wake speaker. to show green status light.

Q: Lithe Audio App not working correctly

A: Ensure your speaker firmware/app are up to date, OR restart/reinstall app fully.

Q: I have a new router and speakers are not visible anymore

A: If you have purchased a new router or reset the router back to default, you shall need to install the speakers again. Please follow the setup procedures for IOS or Android.

For further queries and support questions please visit www.support.litheaudio.com email us at support@litheaudio.com or via our website's live chat service (during working hours)

FCC STATEMENT

This equipment has been tested and found to comply with the limits for a class b digital device, pursuant to part 15 of the FCC rules. these limits are designed to provide reasonable protection against harmful interference in a residential installation. this equipment generates, uses and can radiate radio frequency energy and, if not installed and used in accordance with the instructions, may cause harmful interference to radio communications. however, there is no guarantee that interference will not occur in a particular installation. if this equipment does cause harmful interference to radio or television reception, which can be determined by turning the equipment off and on, the user is encouraged to try to correct the interference by one or more of the following measures:

- Reorient or relocate the receiving antenna.
- Increase the separation between the equipment and receiver.
- Connect the equipment into an outlet on a circuit different from that to which the receiver is connected.
- Consult the dealer or an experienced radio/tv technician for help.

To assure continued compliance, any changes or modifications not expressly approved by the party responsible for compliance could void the user's authority to operate this equipment. (example- use only shielded interface cables when connecting to computer or peripheral devices).

FCC RADIATION EXPOSURE STATEMENT

This equipment complies with FCC RF radiation exposure limits set forth for an uncontrolled environment. this transmitter must not be co-located or operating in conjunction with any other antenna or transmitter. This equipment should be installed and operated with a minimum distance of 20 centimeters between the radiator and your body.

This device complies with part 15 of the FCC rules. Operation is subject to the following two conditions: (1) this device may not cause harmful interference, and (2) this device must accept any interference received, including interference that may cause undesired operation.

EUROPE

Lithe Audio declares that this product herewith complies with the requirements of the EMC Directive 2004/108/EC, Low Voltage directive 2006/95/EC, Eco-Design Directive 2005/32/EC, RoHS Directive 2011/65/EU and the R&TTE Directive 1999/5/EC when installed and used in accordance with the manufacturer's instructions. A copy of the full Declaration of Conformance may be obtained at www.litheaudio.com/support/policies.

Lithe Audio Speakers have a standby mode or remove the power cord from plug socket.

REGULATION INFORMATION

RECYCLING INFORMATION

This symbol on the product or on its packaging indicates that this product shall not be treated as household waste. Instead please deliver it to the applicable collection point for the recycling of electrical and electronic equipment. By recycling this product correctly, you will help conserve natural resources and prevent potential negative environmental consequences. For more detailed information about recycling of this product, please contact your local council office, your household waste disposal service or the shop where you purchased the product(s) from.

THIS DOCUMENT CONTAINS INFORMATION THAT IS SUBJECT TO CHANGE WITHOUT NOTICE.

No part of this publication may be reproduced or transmitted in any form or by any means, electronic or mechanical, including but not limited to photocopying, recording, information retrieval systems, or computer network without the written permission of Lithe Audio Ltd

Image shows Apple iPhone but visuals may change from device to device.
Apple and iPhone are trademarks of Apple Inc., registered in the U.S. and other countries.

Use of the Works with Apple badge means that an accessory has been designed to work specifically with the technology identified in the badge and has been certified by the developer to meet Apple performance standards.

To control this AirPlay 2-enabled speaker, iOS 11.4 or later is required.
Apple, iPad, iPad Air, iPad Pro, iPhone and AirPlay are trademarks of Apple Inc., registered in the U.S. and other countries.

Windows® is a registered trademark of Microsoft Corporation in the United States and other countries.

Android™ is a trademark of Google, Inc.

Google, Chromecast built-in are trademarks of Google LLC.

The Bluetooth® word mark and logos are registered trademarks owned by Bluetooth SIG, Inc. and any use of such marks by Lithe Audio Ltd is under license. Other trademarks and trade names are those of their respective owners.

Wi-Fi CERTIFIED™ is a registered trademark of Wi-Fi Alliance®

Spotify software is subject to third party licenses found here: <http://www.spotify.com/connect/third-party-licenses>

All other products and services mentioned may be trademarks or service marks of their respective owners.

©2020 by Lithe Audio Ltd. All rights reserved.

FCC ID: 2AQOB-LWF1



This warranty may not be valid if the product was purchased via an un-authorized dealer.

The warranty only applies to individual that made the original purchase, not transferable..

The purchaser must show proof of purchase by way of receipt (hard copy or digital copy)

The warranty is null and void if:

- product altered in any way from its original manufactured state
- security seal has been removed
- product defaced

No one is authorised to make or modify any warranty on behalf of Lithe Audio Ltd.



2 YEAR GUARANTEE

This Ceiling Speaker is of excellent quality and construction. However, if any defects in materials or workmanship do appear during the guarantee period, we will, at our discretion, either repair or replace the defective parts, free of charge, subject to the terms and conditions of our Guarantee shown below.

This Guarantee covers both parts and labour. Carriage is not included.

This Guarantee provides benefits which are additional to, and do not affect, your statutory rights. This Guarantee does not cover the cost of returning the product to the dealer from whom it was purchased or to ourselves. This Guarantee applies only to products sold and located in mainland Great Britain. It does not cover liability in respect of or replacement of plugs, cables or fuses and also does not cover defects due to:

- Failure to use or maintain product in accordance with Lithe Audio instructions.
- The product being connected to an unsuitable electricity supply.
- Accidental damage to or abuse or misuse of the product.
- Product modification, except by Lithe Audio or approved agent.
- Dismantling of or interference with the product.

Before returning any product under this Guarantee, please check that:

- You have followed the product instructions correctly.
- Your mains electricity supply is functional.
- The defect is not due to a blown fuse.

If you wish to claim under this guarantee you should:

- Send the product, postage or carriage paid, to the dealer from whom it was purchased or to Lithe Audio direct.
- Ensure that the product is clean and packed carefully (preferably in its original carton).
- Enclose details of your name, address and telephone number and when and where the product was purchased, together with proof of purchase (e.g. a invoice or till receipt).
- Give exact details of the nature of the defect.

This Guarantee does not cover any other claims whatsoever, including, without limitation, any liability for incidental, indirect or consequential damage, nor does it cover any claims for conversion or modification or for the costs of repair carried out by any third party without the prior consent of Lithe Audio. If replacement parts are fitted to the product this will not extend the period of the Guarantee. For further advice contact the Lithe Audio customer services.



Lithe Audio products marked with the CE mark comply with the EC Low Voltage Directive: 73/23/EEC, Electromagnetic Compatibility Directive 89/336/EEC

WWW.LITHEAUDIO.COM

TEL: 01293 922 015 EMAIL: INFO@LITHEAUDIO.COM

