

Float Base - This has been cut 1.5 mm undersize , so once you have glued it together, you can fill the spaces with foam blocks, shape and then cover with balsa and finally glass it to water proof it.

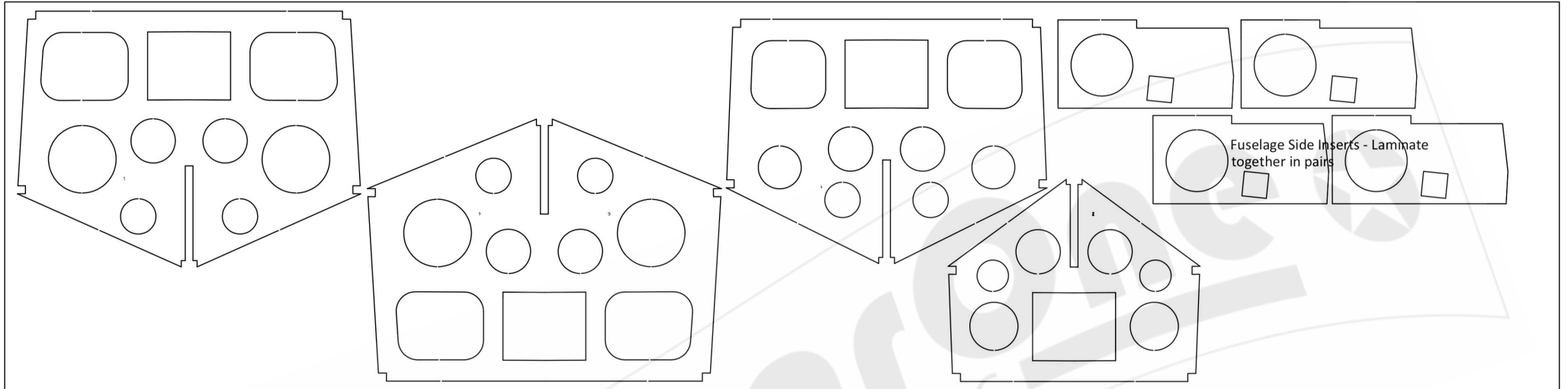

3.0 mm hoop or Poplar??

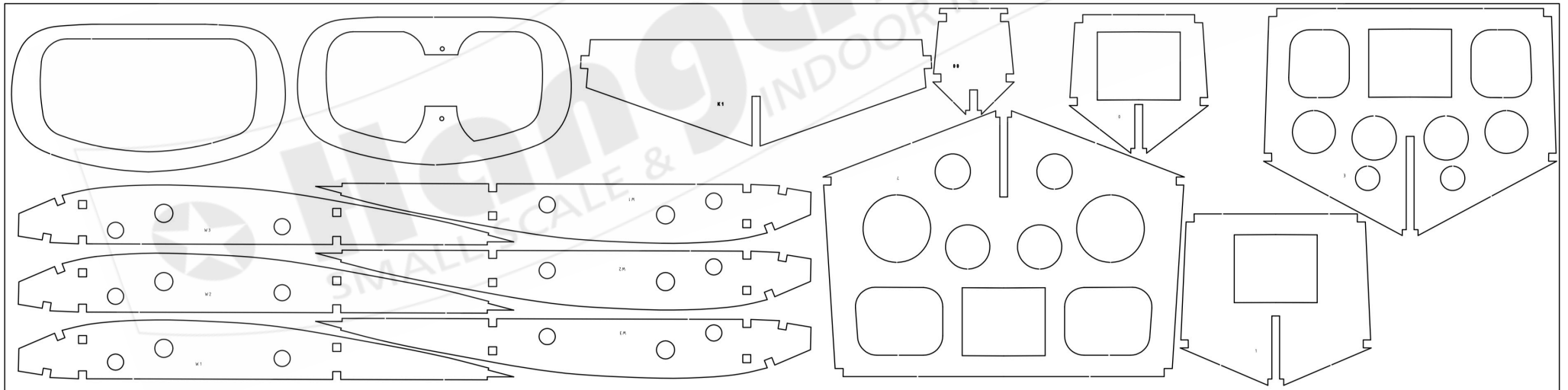

3.0 mm hoop or Poplar??

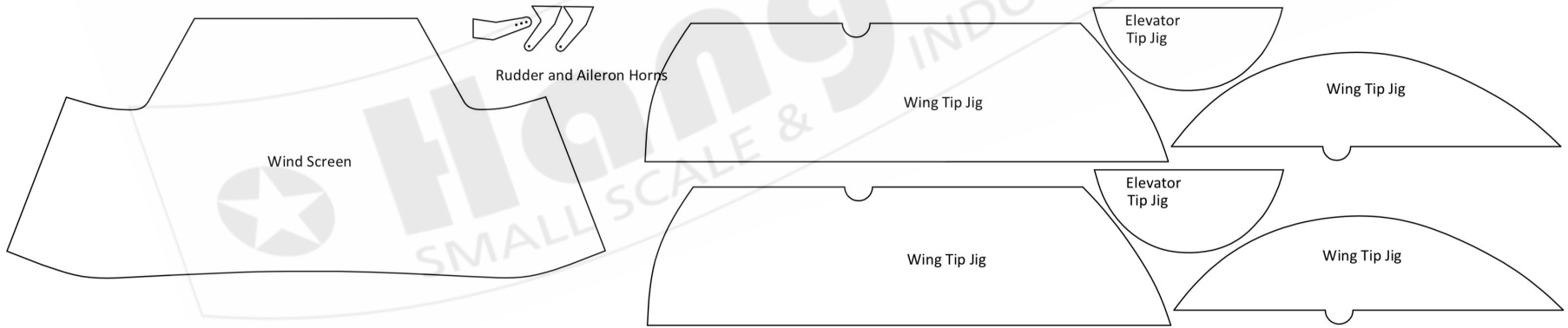
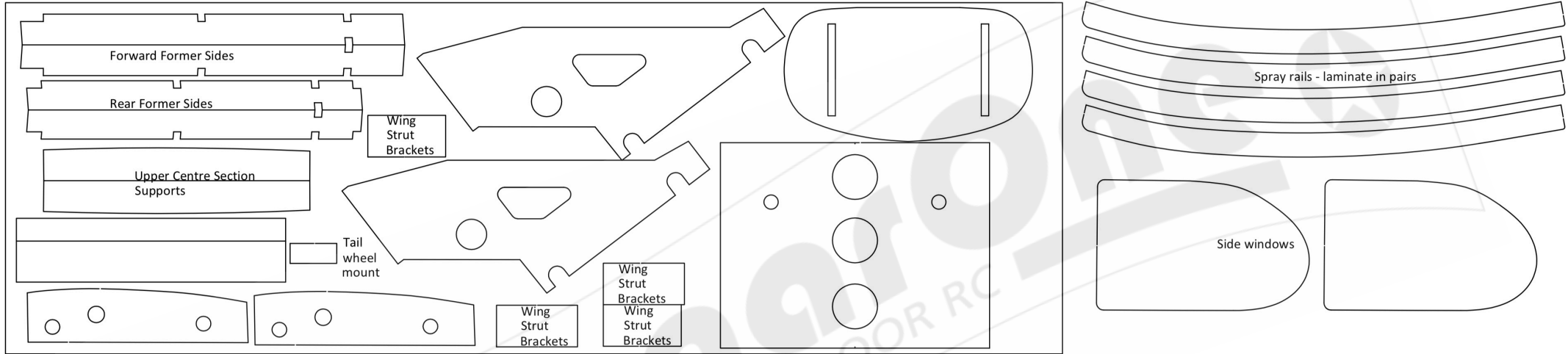

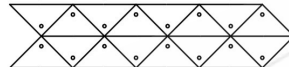
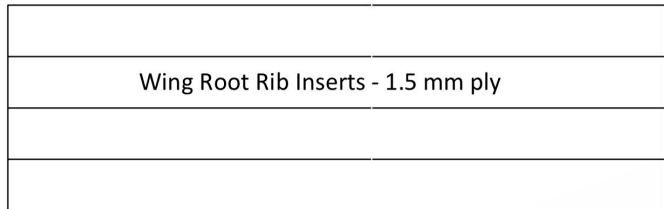

Float Mounts - laminate
5 mm Ply



Tailplane Bracket Mounts -
laminate
5 mm Ply

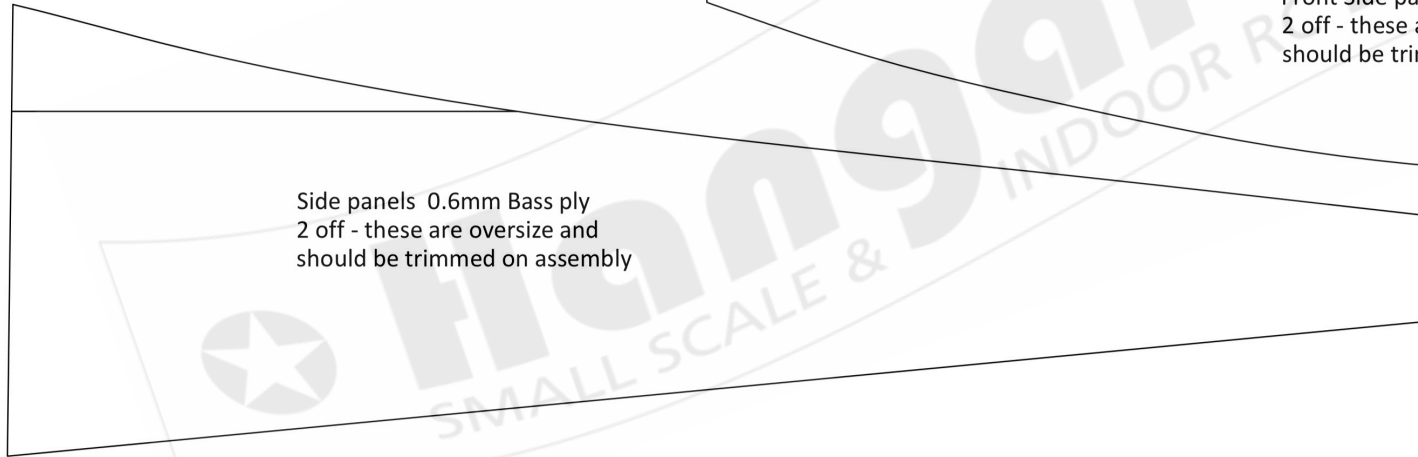
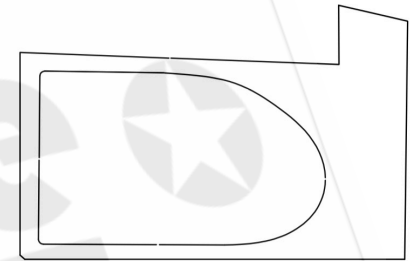

Front Side panels 0.8mm Birch ply
2 off - these are oversize and
should be trimmed on assembly

Side panels 0.6mm Bass ply
2 off - these are oversize and
should be trimmed on assembly

