

# T-Slot Nuts – English

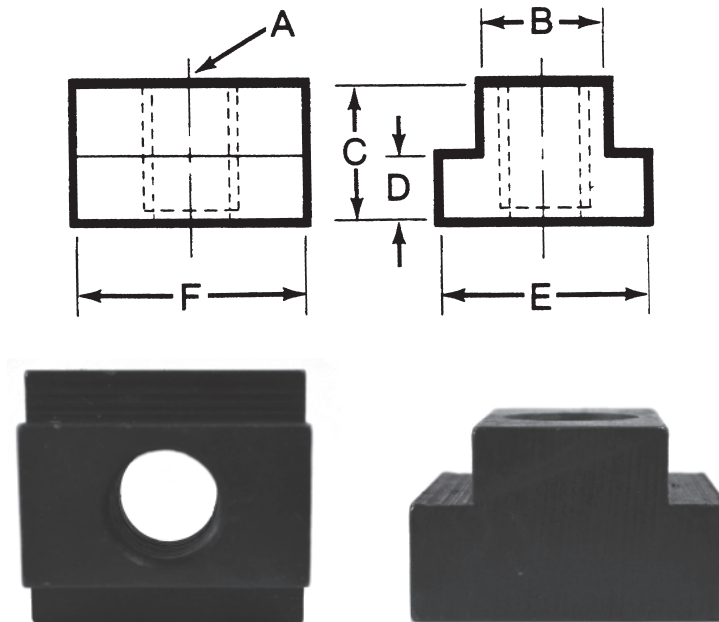

Part No.	English* Table Slot		C	D	E	F
	Thread A	B				
824-41401	1/4-20	5/16	1/4	3/16	9/16	9/16
824-41402	1/4-20	3/8	3/8	15/64	9/16	9/16
824-41403	5/16-18	3/8	3/8	1/4	5/8	7/8
824-41433	5/16-18	7/16	1/2	7/32	11/16	7/8
824-41434	5/16-18	1/2	1/2	9/32	7/8	7/8
824-41404	3/8-16	7/16	1/2	7/32	11/16	7/8
824-41405	3/8-16	1/2	1/2	9/32	7/8	7/8
824-41406	3/8-16	9/16	5/8	11/32	7/8	1-1/8
824-41407	7/16-14	1/2	1/2	9/32	7/8	7/8
824-41408	7/16-14	1/2	3/8	7/32	3/4	7/8
824-41409	1/2-13	9/16	5/8	11/32	7/8	1-1/8
824-41410	1/2-13	5/8	5/8	11/32	1	1-1/8
824-41411	1/2-13	5/8	3/4	3/8	1-1/8	1-1/8
824-41412	1/2-13	11/16	3/4	7/16	1-1/8	1-1/4
824-41413	1/2-13	3/4	3/4	15/32	1-1/4	1-1/4
824-41415	5/8-11	11/16	3/4	7/16	1-1/8	1-1/4
824-41416	5/8-11	3/4	3/4	15/32	1-1/4	1-1/4
824-41417	5/8-11	13/16	1	9/16	1-1/4	1-1/2
824-41418	3/4-10	13/16	1	9/16	1-1/4	1-1/2
824-41419	3/4-10	7/8	1	9/16	1-1/2	1-1/2
824-41420	3/4-10	1	1	5/8	1-5/8	1-3/4
824-41421	3/4-10	1	1-1/2	3/4	1-3/4	1-3/4
824-41422	3/4-10	1-1/16	1-1/8	11/16	1-5/8	2

- Black Oxide Finish
- Case Hardened
- The last thread is incomplete on T-Slot Nuts to prevent the stud from turning through the bottom of the nut.

\* T-Slot Nut are undersized to fit machine table