

Knurl Holders

Self Centering

The Two Die Pivoting Head Bump Holders are designed for CNC lathe, for knurling both straight and diamond patterns. The pivoting head gives precise alignment to the working part. Knurls not included.

Part No.	Knurl	A	B	C	E	F	G
842-203	5/8 x 1/4	.625	1.50	4.5	1.75	.80	.93
842-202	5/8 x 1/4	.750	1.50	4.5	1.75	.80	.93
842-200	3/4 x 3/8	1.00	1.75	5.0	1.95	.97	1.12

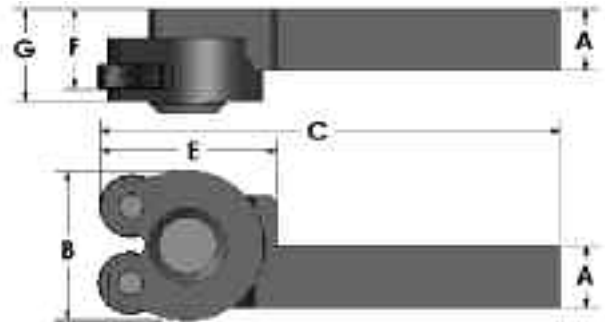

Bump Style

Single Die Bump Holders are best suited to shorter work, or long work where knurling can be done close to the chuck or tailstock. Knurls not included.

Part No.	Knurl	A	C	E	F	G	J
842-216	5/8 x 1/4	.625	4.0	1.00	.525	.625	.12
842-217	3/4 x 3/8	.750	4.5	1.12	.625	.750	.18
842-221	3/4 x 3/8	1.00	5.0	1.50	.875	1.00	.18

