

Spot Drills

Indexable Carbide Spotting Tools (Patent # 5,259,707)

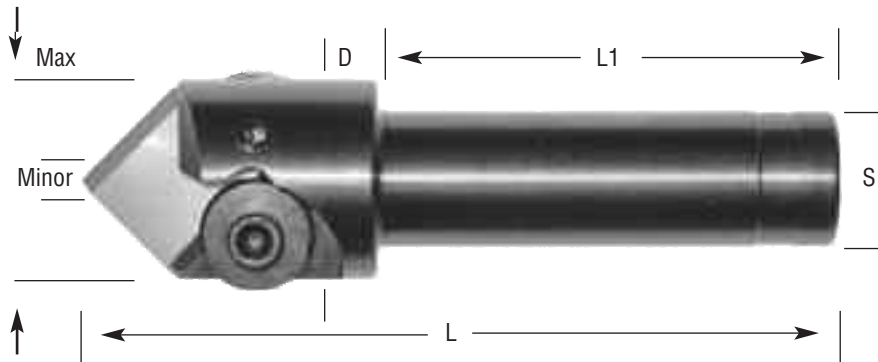

90 DEGREE SPOT DRILLS

K-Tool #	Screw	Min Dia.	Max Dia.	L	L-1	S	D	Insert	Clamp	Tool Body Part No.
SDCS90-500	325B	.093	.500	4.00	-	.500	-	#90-500	251207	805-397
SDCS-90	25618	.070	.390	3.25	2.50	.375	.430	#90	180310	805-400
SDCS-900	44025	.093	.470	3.25	2.37	.500	.625	#900	311205	805-401
SDCS-901	103212	1.56	.600	3.06	2.00	.500	1.00	#901	501912	805-402
SDCS-901L	103212	1.56	.600	5.33	4.25	.750	1.00	#901	501912	805-403
SDCS-902	103212	.250	.900	4.13	2.50	.750	1.12	#902	621915	805-404
SDCS-902L	103212	.250	.900	6.53	4.87	1.00	1.12	#902	621915	805-405

Insert	Part No.
90-500	805-397A
90	805-570
900	805-571
901	805-572
*901CB	805-574
902	805-573
*902CB	805-575

Clamp	Part No.
180310	805-599
501912	805-601
6211915	805-602
311205	805-600
251207	805-596A

Screw	Part No.
25618	805-597
103212	805-596
325B	805-632

Grade A1M TIN COATED
*CB denotes chipbreaker