

S SAVILE
LANE

Design & Style

1

THE CUT

THERE ARE FOUR CUTS AVAILABLE: FULL, MODERATE, TRIM, REPLICATE

FULL CUT

This cut is to provide your client with room and comfort and is also fuller through the entire body, shoulder and arms. Recommended for a portly profile or for the client who prefers a loose fitting shirt. For an average size, our mathematical model adds 7 inches to the chest measurement.

REGULAR CUT

This cut generally follows the client's couture and creates a nice relaxed silhouette. For an average size, our mathematical model adds 5.5 inches to the chest measurement.

TRIM CUT

This cut is typically for the younger, slimmer and slender silhouette. It lays much closer to the body. For an average size, our mathematical model adds 4.75 inches to the chest measurement.

REPLICATE

This replicates the cut of a sample shirt for the customer.

NOTE:

Our system applies a mathematical model to determine the client's offsets. The information provided is for a average size male.

2 COLLAR

2.1



Traditional Point



Spread



Traditional Band Collar (add \$10)

*Additional collar styles available upon request. Nominal upcharge incurred.

2.2



Collar Stays



Button Down



Hidden Button Down

2.3



Small

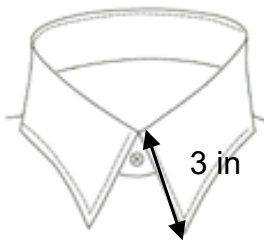

Medium

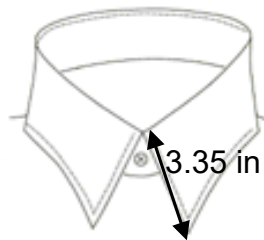

Large

2.3 **Contrast collar** (add \$5) Indicate the fabric to be used.

3 CUFF

3.1

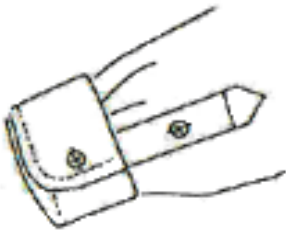

Rounded

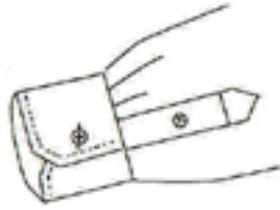

Angle

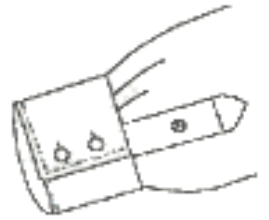

Rectangle

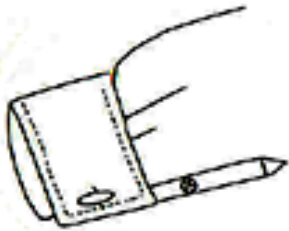

French (add \$5)

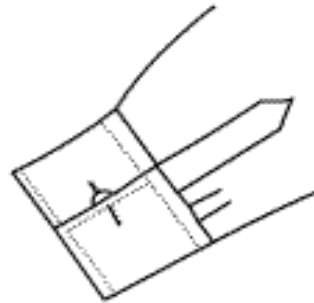

Reversible (add \$5)

3.2

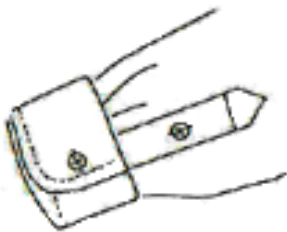

One Button

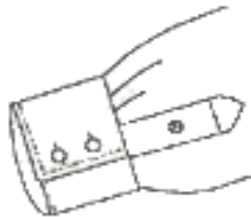

Two Button

*This applies to only rounded, angle and rectangular cuffs.

3.3 Contrast cuff (add \$5)

4

FRONT PLACKET



Tab



French



Covered French
(add \$5)

5

FRONT POCKET



One Pocket



No Pocket

6 BACK PLEATS

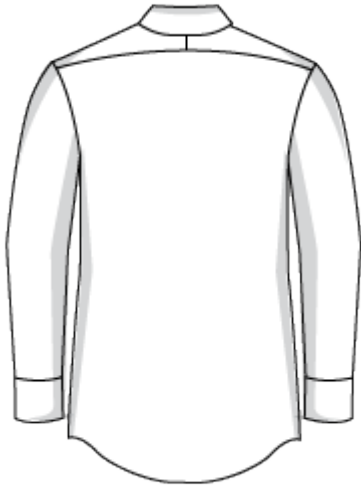

No Pleats



Box Pleat



Side Pleats

7 STITCHING

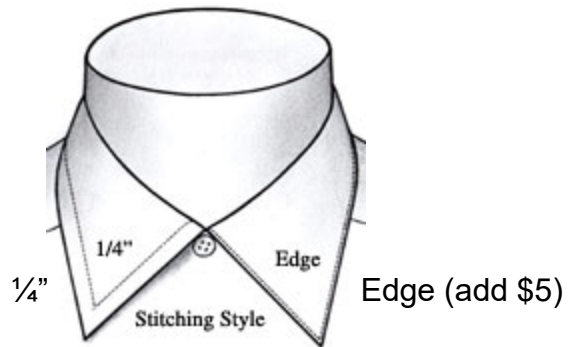

8**MONOGRAM (add \$8)**

FONT STYLE: Indicate the style number

COLOR: Specify the color – NAVY, BLACK, WHITE

MONOGRAM PLACEMENT: Specify LEFT CUFF or RIGHT CUFF.

