

SWIFTY BOOSTER

Your Booster is compatible with SwiftyONE, SwiftyZERO & SwiftyAIR.

Notice: Only use removable wing nuts on SwiftyONE.

ASSEMBLY GUIDE

Please read these instructions carefully. If you have any queries relating to the safe assembly or installation of your Booster do not hesitate to contact us.

TOOLS NEEDED

8mm Spanner

PARTS CHECK LIST

2 × Coach Bolts



2 × Split Washers



2 × Nylock Nuts
(Permanent)



2 × Wing Nuts
(Removable)



1 × Booster Deck (pre-assembled)

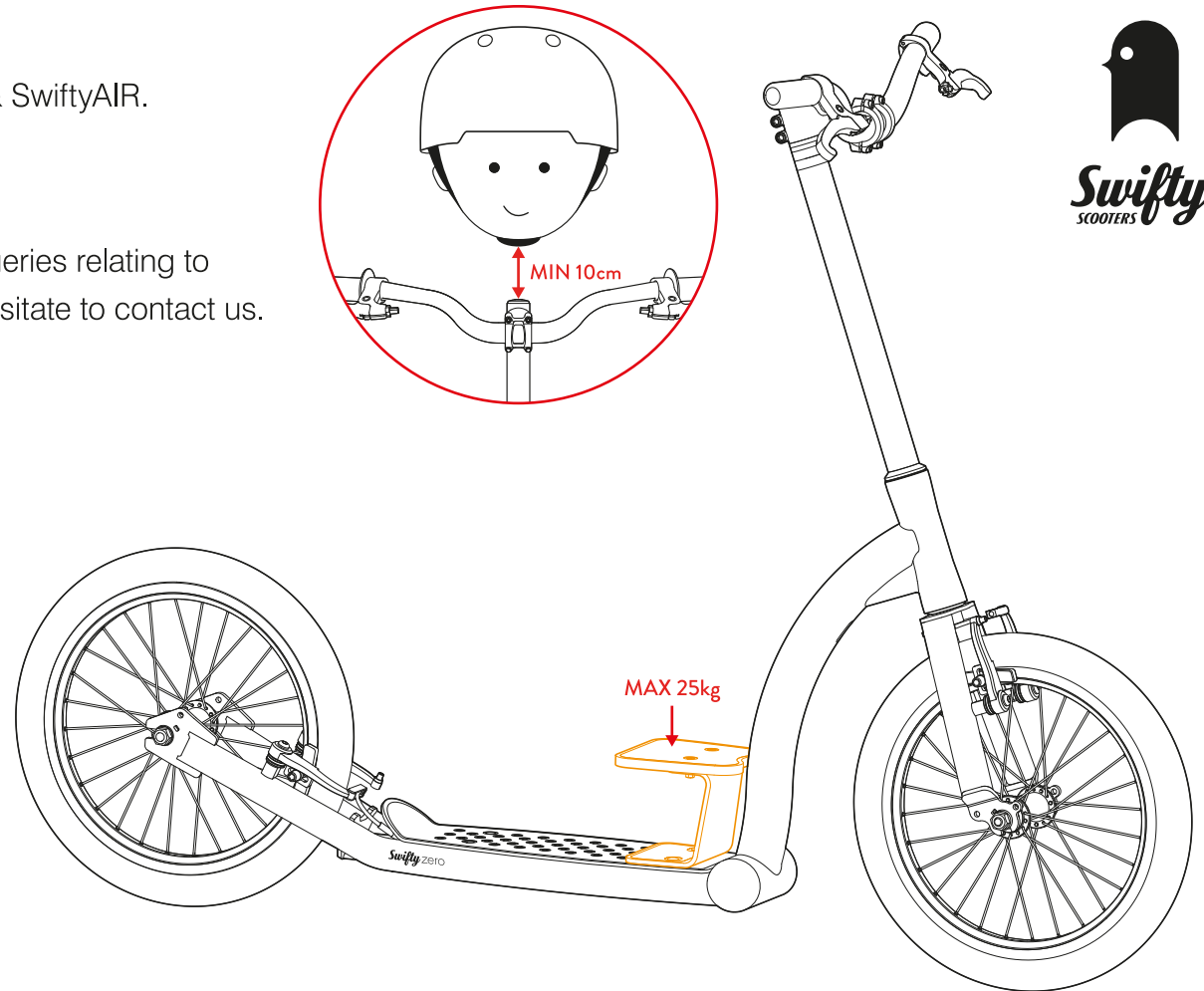
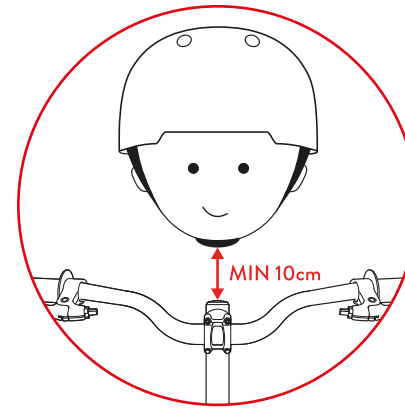
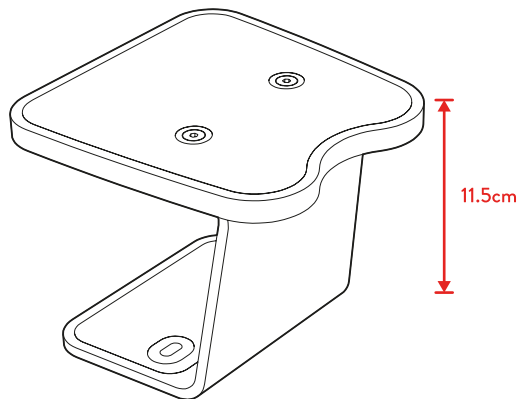

RIDER RESTRICTIONS & SAFETY

- Designed for children aged between 2-4 years, between 85cm-100cm tall & up to 25kg in weight.
- The maximum total rider weight for the scooter is 150kg.
- Ensure your child is wearing protective equipment, e.g. Helmet, Elbow & Knee Pads.
- Adjust your speed and allow extra time for braking to ensure your child has a safe and comfortable ride.
- Ensure the handlebars are below your child's chin, adjust the handlebar height of SwiftyONE if needed.



Let the good times ride and roll!
Share your story and follow us @swiftyscooters

WWW.SWIFTYSCOOTERS.COM

HOW TO INSTALL

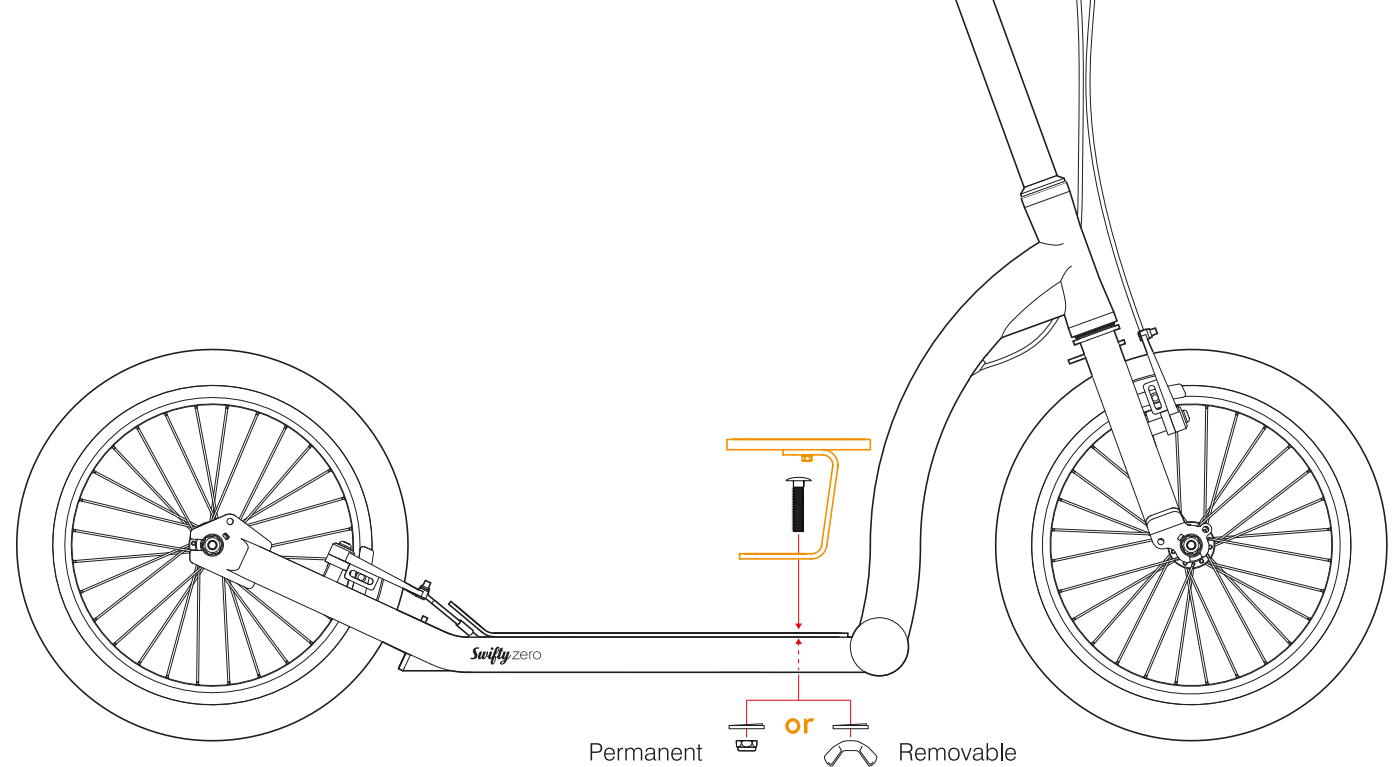
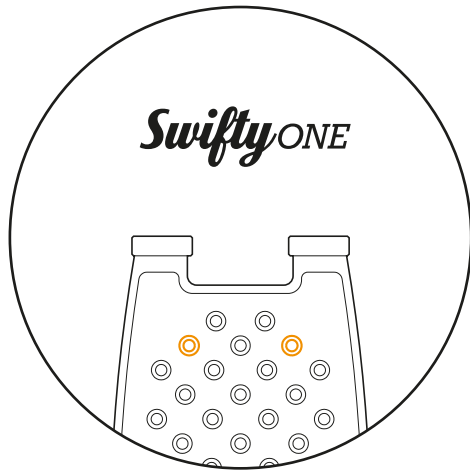

SWIFTY ONE

Place the booster at front of your scooter footplate as shown above, line the deck up with the footplate holes specified in the drawing on the left. Put the coach bolts through the holes, then fix with removable wing nuts* and split washers provided.

* The Booster must be removed to fold SwiftyONE, use removable wingnuts provided.

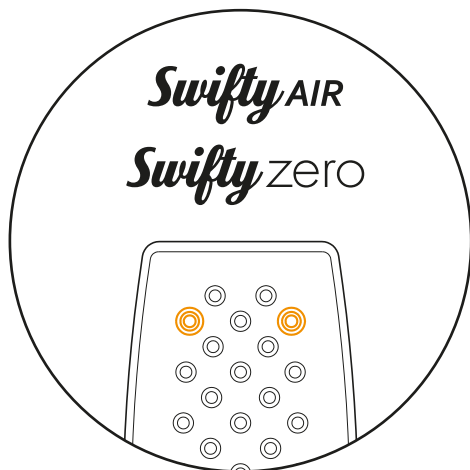

SWIFTY AIR & ZERO

Remove the front two bolts from your footplate, keep them in a safe place in case you want to remove the Booster deck at a later date. Line the deck up with the bolt holes specified in the drawing on the left, and fix in place using the coach bolts, split washers and nuts provided.

 Warning: Ensure nuts are fully tightened before each ride.



Let the good times ride and roll!
Share your story and follow us @swiftyscooters

WWW.SWIFTYSCOOTERS.COM

