

# Easicom

Quality, reliability, flexibility



# Easicom

## Quality, reliability, flexibility

The Easicom from Glow-worm is a high efficiency A-rated boiler which comes with a choice of outputs, models and warranties to suit.

Designed with a high quality and powerful aluminium heat exchanger, Easicom has leading features, a bright easy to read LCD display and comes with a 3 year guarantee as standard, with the option to extend\*.

The Easicom is delivered as a boiler, flue and analogue timer package (combi only) and is supported by a UK brand you can trust with industry leading service, support and an award winning loyalty programme.



\*When registered through Club Energy.



#### Exclusive Glow-worm boiler

Developed exclusively for independent merchant branches to meet installer requirements.



#### Wide range of models

Available in a range of combi, system and regular models to suit any installation.



#### High quality automotive grade aluminium heat exchanger

Designed to last longer, it is easy to maintain, ultra quiet and reduces customers' energy bills.



#### Bright LCD display

Excellent clarity boiler display wherever it is installed making it easy to change and confirm settings.



#### High Efficiency modulating Grundfos pump

Lower running costs as pump adapts to actual heating and hot water demand.



#### ErP A rated

High efficiency boiler range with A rated label to meet ErP legislation. Comes with online labelling tool for installers.



#### Compatible with full range of Glow-worm controls

Wide range of controls from the inbuilt analogue timer to the MiGo app based control.



#### Supported by **clubenergy**

Full suite of support tools including instant Gas Safe notifications, access to extended warranties and the Plumbing Toolbox app making installation and administration easier.



#### 3 year parts and labour standard guarantee

Register through Club Energy for option to extend to 4 year warranty



## Easicom

With the introduction of the latest Easicom generation, Glow-worm has expanded the highly efficient range of combi boilers to now include system and regular (open vent) models. Naturally, all models in the range are ErP A rated and come with a choice of outputs and warranties to suit.

Both the combi and the new system and regular models use a high quality automotive grade aluminium heat exchanger that makes the boiler not only light to install but also easy to maintain. Additional leading features include the bright, easy to read LCD display and the backup of a 3 year standard guarantee, with the option to extend\*.

The Easicom combi boiler features an inbuilt analogue timer as standard. On top of this, all three models are delivered as a boiler and flue package that is compatible with the full range of Glow-worm controls including the MiGo app based control. Of course, a Glow-worm boiler always comes with our industry leading service, support and the award winning loyalty programme, Club Energy.

\*When registered through Club Energy



3 year warranty\* with option to extend.



ErP A rated



Ultra quiet operation



Easy to install and service



Wide range of models

Easicom range	24c	28c	25S	25F
Casing dimensions (h w d)	740mm x 418mm x 300mm	740mm x 418mm x 300mm	740mm x 418mm x 300mm	600mm x 375mm x 280mm
DHW flow rate storage/combi (l/min, 35°C rise)	10	11.7	N/A	N/A
Max horizontal Ø60/100	10m	10m	10m	10m
Max vertical Ø60/100	10m	10m	10m	10m
SEDBUK 2009 annual efficiency (%)	89.3	89.3	TBC	TBC
ErP Rating Heating	A	A	A	A
ErP Rating DHW	A	A	N/A	N/A

## Easicom combi boiler

### Product features and benefits

- Combi boiler range with the choice of 24 or 28 kW outputs
- Bright LCD display with easy to use interface
- Instant hot water supply\*
- Compact, smart design to suit modern homes
- High quality automotive grade aluminium heat exchanger, providing excellent performance
- High efficiency, A rated boiler for ErP energy labelling to reduce energy bills
- Grundfos modulating pump for reduced energy use
- Compatible with full range of Glow-worm controls, flues and accessories
- Independent merchant package includes boiler, horizontal flue and inbuilt analogue timer
- 3 year parts and labour guarantee, with an extended warranty option available through Club Energy
- Telescopic flue option available
- $\varnothing 60/100$  and  $\varnothing 80/125$  flue options available
- Wide range of accessories available, including spacing frame and pipe cover plate
- Plume management kit compatible



\* 5 second delivery within 5 metres of hot tap

## Easicom system boiler

### Product features and benefits

- System boiler in 25kW output
- Bright LCD display with easy to use interface
- Compact, smart design to suit modern homes
- High quality automotive grade aluminium heat exchanger, providing excellent performance
- High efficiency, A rated boiler for ErP energy labelling to reduce energy bills
- Grundfos modulating pump for reduced energy use
- Compatible with full range of Glow-worm controls, flues and accessories
- Independent merchant package includes boiler and standard horizontal flue
- 3 year parts and labour guarantee, with an extended warranty option available through Club Energy
- Telescopic flue option available
- $\varnothing 60/100$  and  $\varnothing 80/125$  flue options available
- Wide range of accessories available, including spacing frame and pipe cover plate
- Plume management kit compatible



## Easicom regular boiler

### Product features and benefits

- Regular boiler in 25kW output
- Bright LCD display with easy to use interface
- Compact, smart design to suit modern homes
- High quality automotive grade aluminium heat exchanger, providing excellent performance
- High efficiency, A rated boiler for ErP energy labelling to reduce energy bills
- Compatible with full range of Glow-worm controls, flues and accessories
- Independent merchant package includes boiler and horizontal flue
- 3 year parts and labour guarantee, with an extended warranty option available through Club Energy
- Telescopic flue option available
- $\varnothing 60/100$  and  $\varnothing 80/125$  flue options available
- Wide range of accessories available, including pipe cover plate
- Plume management kit compatible



# Technical specifications

## Easicom combi boiler

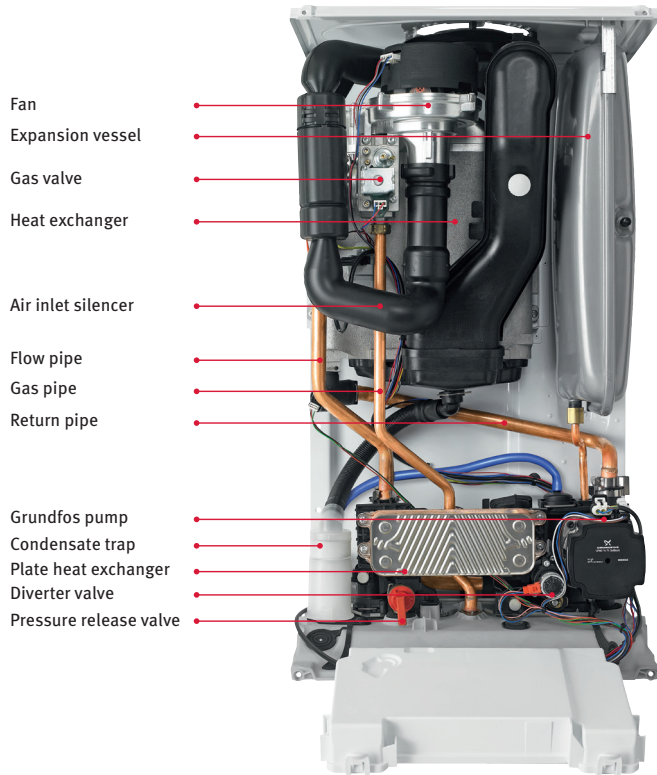

## Easicom system boiler

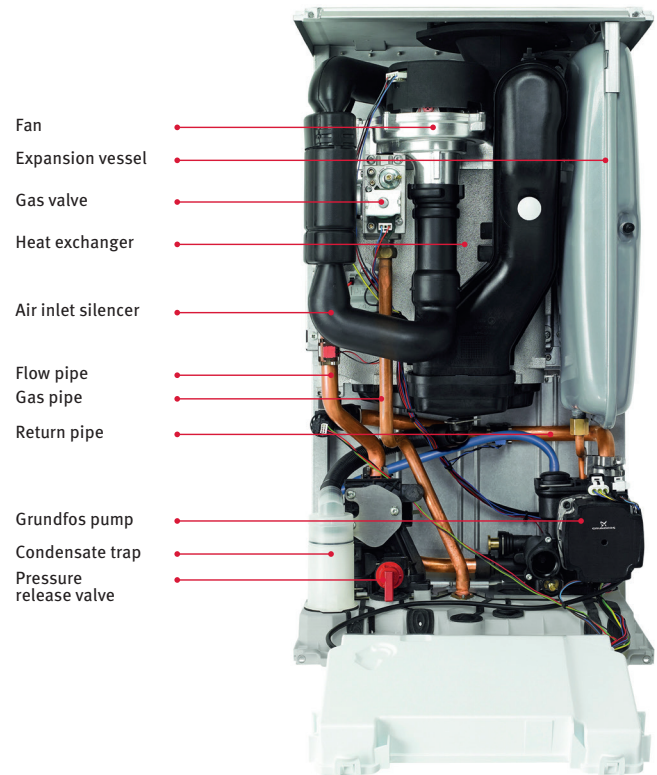

## Easicom regular boiler

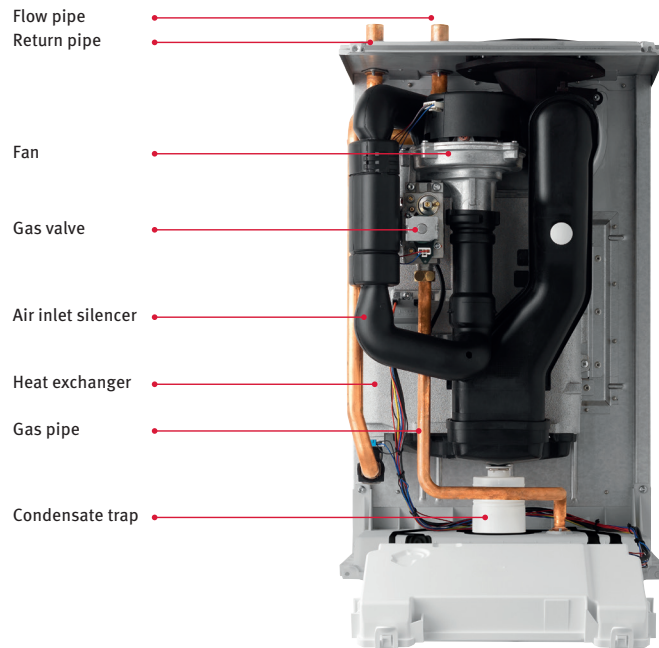



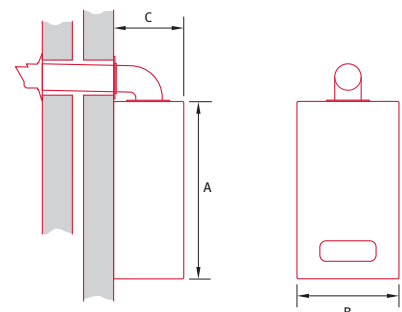

Dimensions								
24c and 28c			25S			25r		
Height (A)	Width (B)	Depth (C)	Height (A)	Width (B)	Depth (C)	Height (A)	Width (B)	Depth (C)
740mm	418mm	300mm	740mm	418mm	300mm	600mm	375mm	280mm





# Technical specifications

	combi		system	regular
				
<b>Easicom boilers</b>	<b>24C</b>	<b>28C</b>	<b>25S</b>	<b>25R</b>
Article number	0010016114	0010016116	0010020902	0010020907
Casing dimensions (h w d) (mm)	740 x 418 x 300	740 x 418 x 300	740 x 418 x 300	600 x 375 x 280
Weight (lift) (kg)	32	33	31.9	22
<b>Performance</b>				
CH output (kW) Min/Max	5.0/21.2	6.3/25.7	6.3/25.5	6.4/26.5
DHW output (kW) CH output (kW) Min/Max	5.0/24	6.0/28	6.0/30.0	6.0/30.0
DHW flow rate storage/combi (l/min. 35°C rise)	10.0	11.7	N/A	N/A
SEDBUK rating 2009	89.3	89.3	TBC	TBC
NOx class (natural gas)	5	5	5	5
LPG compatible	No	No	No	No
ErP Rating Heating	A	A	A	A
ErP Rating DHW	A	A	N/A	N/A
<b>Construction</b>				
Heat exchanger material	Aluminium	Aluminium	Aluminium	Aluminium
Burner type	Pre-mixed	Pre-mixed	Pre-mixed	Pre-mixed
Fully modulating	Yes	Yes	Yes	Yes
DHW plate heat exchanger	Yes	Yes	N/A	N/A
Integrated hydrobloc	Yes	Yes	N/A	N/A
<b>Installation</b>				
Suitable for sealed systems	Yes	Yes	Yes	Yes
Inbuilt adjustable system bypass	Yes	Yes	N/A	N/A
Inbuilt condensate trap/siphon	Yes	Yes	Yes	Yes
Inbuilt boiler frost protection	2 stage	Yes	Yes	Yes
Zero compartment ventilation	Yes	Yes	Yes	Yes
Pump	Grundfos	Grundfos	Grundfos	N/A
<b>Clearances</b>				
Top (mm) (from top of boiler)	300	300	300	300
Side (mm)	5mm*	5mm*	5mm*	5mm*
Bottom (mm)	300	300	300	300
Front (mm) <sup>2</sup>	600**	600**	600**	600**
<b>User Interface</b>				
User display	Super bright LCD	Super bright LCD	Super bright LCD	Super bright LCD
Diagnostics	Advanced	Advanced	Advanced	Advanced
User adjustable CH temp control	Yes	Yes	Yes	Yes
User adjustable DHW temp control	Yes	Yes	Yes	N/A
<b>Pipes</b>				
Optional spacing frame	Yes	Yes	Yes	No
Water connections	2x22/2x15mm	2x22/2x15mm	2x22/2x15mm	2x22/2x15mm
<b>Flues</b>				
Max horizontal ø60/100	10m	10m	10m	10m
Max vertical ø60/100	10m	10m	10m	10m
Max horizontal ø80/125	25m	25m	25m	25m
Max vertical ø80/125	25m	25m	25m	25m
Optional plume management kit ø60/100	Yes	Yes	Yes	Yes

\*See manual for clearance if side panels are to be removed to assist future service and maintenance

\*\*5mm if removable panel/door

# Intelligent controls

Easicom combi models feature an integrated analogue timer as standard. In addition, these models are also compatible with a great choice of intelligent controls, to deliver the most efficient heating system for your customers.

## The world of controls explained

**Weather compensation** uses an outdoor sensor to measure outside temperature and adjusts the flow temperature to meet daily heating demands. The colder it is outside, the hotter the flow temperature to the radiators. As the weather gets warmer the flow temperature is cooler. This ensures the boiler operates in the most efficient way to maintain stable temperature levels and lower energy bills further.

### Mechanical timer and Climastat thermostat

- Wall mounted Climastat connects using simple low voltage eBus
- Traditional interface for customers to set heating programmes
- eBus connected Climastat means the boiler will modulate to manage heating in the most efficient way possible
- Heating and hot water mode on indicator
- Maintenance indication
- Clear digital display with 0.5°C temperature intervals
- Wide temperature range 5 - 30°C
- For use with integrated analogue timer on combi and system models



Factory fitted analogue timer	✓
Room thermostat	
Programmable room thermostat	
Wireless controls	
Load compensation	✓

Weather compensation not possible

### Climapro<sub>1</sub> wired and wireless programmable thermostat

- Secure wall mounted thermostat is wired using simple low voltage eBus
- User friendly design with bright backlight
- Clear straightforward menus to set heating and hot water programmes
- Annual service reminder and auto daylight saving time
- eBus connected Climapro<sub>1</sub> means the boiler will modulate to manage heating in the most efficient way possible
- Weather compensation using a simple wireless outdoor sensor
- Climapro<sub>1</sub> RF wireless version available
- Climapro<sub>1</sub> wired version can be used with the smart wiring centre to offer two heating and one hot water zone (S Plan Plus)
- Automatic daylight savings time



Plug in timer	
Room thermostat	
Programmable room thermostat	✓
Wireless controls	
Load compensation	✓
Weather compensation*	✓

\*When an outdoor sensor is included

\*Class VI possible when used with outdoor sensor



## Climapro<sub>2</sub> wireless programmable thermostat

- Wireless thermostat works anywhere in the home
- Wall bracket for base location and secure storage
- RF receiver slots into the boiler, simple wireless setup, no electrician required
- User friendly design with bright backlight
- Clear straightforward menus to set heating and hot water programmes
- Annual service reminder and auto daylight saving time
- eBus connected Climapro<sub>2</sub> RF means the boiler will modulate to manage heating in the most efficient way possible
- Weather compensation using a simple wireless outdoor sensor

**ErP Class VI**  
**+4%\***



Plug in timer	
Room thermostat	
Programmable room thermostat	✓
Wireless controls	✓
Load compensation	✓
Weather compensation*	✓

\*When an outdoor sensor is included

## MiGo app based programmable room thermostat

- Smart phone app for Apple and Android devices to manage heating and hot water on the go
- Simple and straightforward installation - installed and running in less than 30 minutes
- Easy and intuitive interface - fast and straightforward temperature control
- Self learning - MiGo automatically learns the energy requirements of your home
- Installation assistant - seriously simple step by step pairing process
- Internet weather compensation - MiGo only ever uses your energy as and when it needs to without the need for an outside temperature sensor
- eBUS communication - MiGo and Glow-worm boilers speak the same 'language'!
- One heating circuit and DHW management - DHW and central heating control from one device
- In room thermostat can be wall mounted or a portable table top version
- Electronic paper display - clear display with low energy consumption
- Multi-user sharing and multi-home control - you and your family can manage several heating systems for the same or different locations



**ErP Class VI**  
**+4%\***

Plug in timer	
Room thermostat	
Programmable room thermostat	
Wireless controls	✓
Smartphone app controls	✓
Load compensation	✓
Weather compensation	✓

## Training

Glow-worm offers a range of training facilities covering the complete Glow-worm range. To find out more please call [01773 596156](tel:01773596156) or email [training@glow-worm.co.uk](mailto:training@glow-worm.co.uk)

## Support

Expert advice and support from installation to maintenance

Technical help

- If you have a technical question simply call our technical help line on [0330 100 7679](tel:03301007679) or email [technical@glow-worm.co.uk](mailto:technical@glow-worm.co.uk) for a straightforward answer

Genuine high quality spares

- Spares availability for up to 15 years after production ends
- Nationwide spares stockists with over 500 locations
- Next day delivery service for emergency orders - contact spares on [01773 596 090](tel:01773596090) or [spares@glow-worm.co.uk](mailto:spares@glow-worm.co.uk)

## Nationwide after sales service

- Supporting you with technical help and after sales service online, over the telephone and on the road
- 250 engineers based around the UK, carrying over 1,500 different spare parts
- 97% first time fix rate

For our service department please call [0330 100 7678](tel:03301007678)  
email [customerservice@glow-worm.co.uk](mailto:customerservice@glow-worm.co.uk)  
or visit [www.glow-worm.co.uk](http://www.glow-worm.co.uk)



# clubenergy

## The award winning loyalty programme from Glow-worm

Enjoy great member benefits when you register your Easicom installations including...



**Free 4 year warranty**  
When registered through Club Energy, option to extend



**Business development**  
Free tools to grow your business



**Plumbing Toolbox app**  
Industry leading Plumbing Toolbox app makes managing your installation easier



**Training**  
Free training



**Business tools**  
including instant Gas Safe notifications

## Plumbing Toolbox - the industry leading installer app for Club Energy members

Designed to make your working life easier!

The Plumbing Toolbox app includes loads of useful stuff...



**Register your Installs**



**Merchant locator**  
no more wild goose chases



**Fix that fault**  
quick and easy fault code identification



**Every manual**  
wherever you are, right there in your pocket



**Service reminders**  
helping to keep you organised



To find out more about how you can benefit from Club Energy or join free today visit [www.clubenergy.co.uk](http://www.clubenergy.co.uk) or call 01865 893417



### Literature

There are a number of easy ways for you to access Glow-worm product literature:

- Via our installer app - Plumbing Toolbox
- Via telephone **01773 596 105**
- Available to download online at [www.glow-worm.co.uk](http://www.glow-worm.co.uk)
- Via email [literature@glow-worm.co.uk](mailto:literature@glow-worm.co.uk)

# Glow•worm

The energy you need



INVESTORS  
IN PEOPLE

Gold  
Until 2019

Head office  
01773 824 639  
info@glow-worm.co.uk

Literature  
01773 596 013  
literature@glow-worm.co.uk

Service department  
0330 100 7678  
customerservice@glow-worm.co.uk

Installer technical support  
0330 100 7679  
technical@glow-worm.co.uk

Training  
01773 596 156  
training@glow-worm.co.uk

Spare parts  
01773 596 090

Club Energy  
01865 893417  
clubenergy.co.uk

**Glow-worm**

Nottingham Road  
Belper  
Derbyshire  
DE56 1JT

[www.glow-worm.co.uk](http://www.glow-worm.co.uk)

