

# Contemporary Dummy Lever Installation Instructions



L00-YV40014 Rev. 14/02-01

## USE AND CARE GUIDE GUIDE D'UTILISATION ET D'ENTRETIEN GUÍA DE USO Y CUIDADOS

**1** FOR  
POUR  
PARA

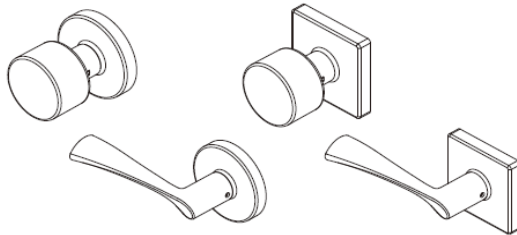

**2** Safety Information  
Informations de sécurité  
Información de seguridad

Read the precautions and instructions in this manual before installing and using this lock. Save this manual for future reference.

Lisez les consignes et instructions contenues dans le présent manuel avant d'installer et d'utiliser cette serrure. Conservez ce manuel pour consultation ultérieure.

Lea las advertencias e instrucciones en este manual antes de instalar y usar esta cerradura. Guarde este manual para consultas futuras.



### WARNING/AVERTISSEMENT/ADVERTENCIA:

If the door needs to be drilled, be familiar with how to use your drill safely, and understand all the door preparation steps before proceeding.

S'il faut percer la porte, sachez comment utiliser adéquatement votre perceuse et assurez-vous que vous connaissez toutes les étapes de préparation de la porte avant de continuer.

Si debe perforar la puerta, sepa cómo usar su taladro con seguridad, y entienda todos los pasos de preparación de la puerta antes de proceder.



### CAUTION/ATTENTION/ADVERTENCIA:

Before beginning the installation, please read and understand the entire manual.

Avant de continuer l'installation, veuillez lire et comprendre tout le manuel.

Antes de comenzar la instalación, lea y entienda todo el manual.



### NOTE/REMARQUE/NOTA:

To ensure a long lasting finish, remove the locks, or do not install the locks, prior to painting your door. Periodically clean the locks with mild soap and a soft cloth. Do not use abrasives or harsh chemicals, and avoid sharp or scratching objects.

Pour assurer un fini durable, retirez les serrures, ou ne les installez avant de peindre votre porte. Nettoyez régulièrement les serrures avec un savon doux et un chiffon doux. Évitez les produits abrasifs ou chimiques agressifs, et évitez les objets pointus ou susceptibles de gratter.

Para garantizar un acabado de larga duración, retire las cerraduras, o no instale una cerradura, antes de pintar la puerta. Limpie las cerraduras periódicamente con jabón y paño suaves.

No use productos químicos abrasivos o agresivos, y evite los objetos afilados o que puedan causar rayones.

**3**

Pre-Installation —  
Tools Required/Hardware Included

Pré-installation —  
Outils nécessaires /matériel inclus

Instalación previa —  
Herramientas necesarias/Hardware incluido



Optional  
Facultatif  
Opcional

Part Pièce Parte	Description Description Descripción	Quantity Quantité Cantidad
AA	Latch/Strike Plate Screws / Vis de la plaque de la serrure/gâche / Tornillos del cerrojo/cerradero	3
BB	Set screw / Vis de serrage / Tornillo de fijación	1
CC	Allen wrench / Clé hexagonale / Llave Allen	1



Note: Not to scale.

Remarque: Pas à l'échelle.

Nota: No está a escala.



AA



BB



CC

# Contemporary Dummy Lever Installation Instructions



## TEMPLATE MODÈLE PLANTILLA

**NOTE:** Double check your product for the correct hole sizes.  
**REMARQUE:** Vérifiez attentivement votre produit pour vous assurer que les tailles du trou sont correctes.  
**NOTA:** Verifique nuevamente los tamaños correctos de los orificios para su producto.

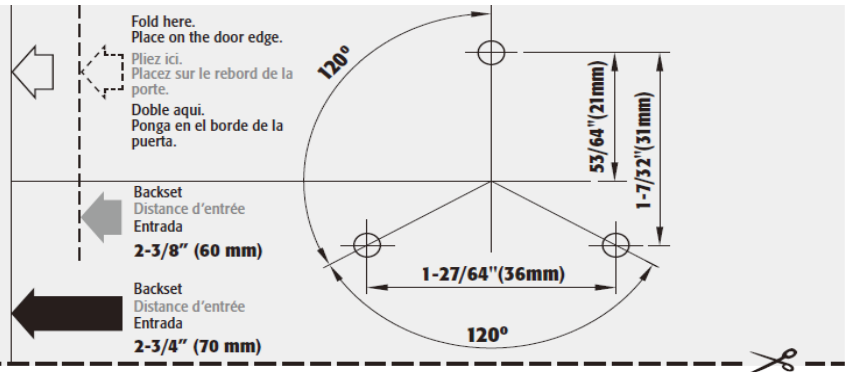

Part Pièce Parte	Description Description Descripción	Quantity Quantité Cantidad
A	Interior lever / Levier intérieur / Palanca interior	1
B	Interior rose / Rose intérieur / Roseta interior	1
C	Inside square plate / Plaque carrée interne / Disco cuadrado interior	1
D	Interior rose plate / Plaque rose intérieur / Placa de la roseta interior	1

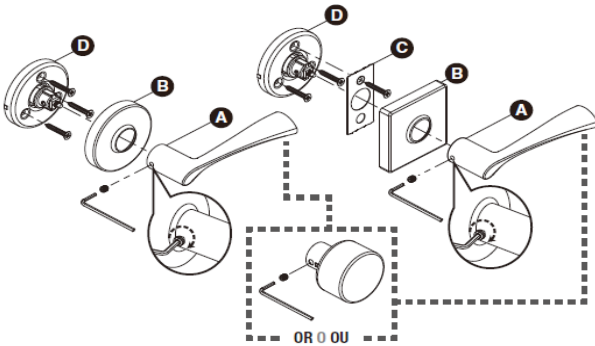

## 4 Installation Installation Instalación

