

### Applications

- Heavy-duty surface mounted door closer suitable for high traffic, high wind & heavy door applications.
- Tri-packed for standard, parallel & top jamb installation.
- Interior Door widths to 60 inches.
- Exterior Door widths to 54 inches.
- Door Weights to 330 lbs.

### Certifications

- ANSI/BHMA Grade-1.
- UL Listed - Compliant for positive pressure.
- Conforms to UL10C & UBC7-2-1997.
- Independently tested to 10 Million Cycles.

### Warranty

- Lifetime Mechanical Warranty.
- Two Year Finish Warranty.

### Closer Functions

- Size 1-6 (adjustable).
- Barrier Free.
- Adjustable closing & latching speeds.
- Standard Back-check.

### Closer Features

- Cast iron body.
- Forged steel arm.
- Double heat treated steel pinion.
- 6 Stick-on mounting templates included.
- Plastic Cover Standard.
- Thru-bolts included.
- Non-handed.
- Aluminum (AL) and Duro-Bronze (DB) finishes.

### Closer Arm Options

- Cushion Stop Arm - PT-C88-CSA
- Hold Open Cushion Stop Arm - PT-C88-CHO

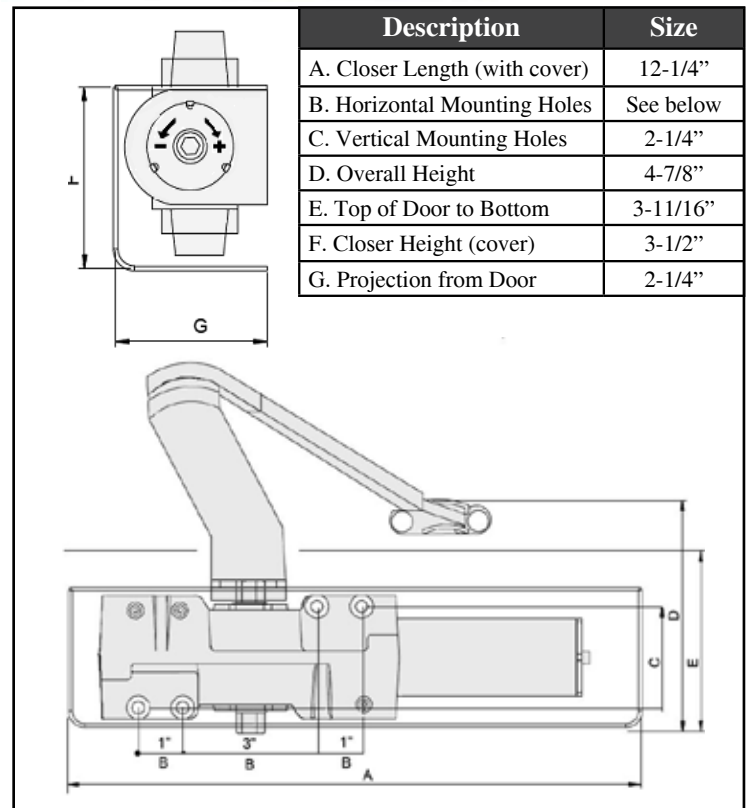

UL LISTED



Meets ADA Regulations

### Competitor Cross References

	Cal-Royal	K2	LCN	Norton	Pamex	Russwin	Sargent	Yale
<b>CL8844</b>	CR441	-	4041	7500	-	2820K	1230	4400