

Commercial Hardware 8600 - ANSI/BHMA Grade-1 Heavy Duty Door Closer Specifications

Applications

- Heavy-duty surface mounted door closer suitable for high traffic, high wind & heavy door applications.
- Tri-packed for standard, parallel & top jamb installation.
- Interior Door widths to 60 inches.
- Exterior Door widths to 48 inches.
- Door Weights to 300 lbs.

Certifications

- ANSI/BHMA Grade-1.
- UL Listed - Compliant for positive pressure.
- Conforms to UL10C & UBC7-2-1997.
- Independently tested to 2 million cycles.



Warranty

- Lifetime Mechanical Warranty.
- Two Year Finish Warranty.

Closer Functions

- Size 1-6 (adjustable).
- Barrier Free.
- Available Delayed Action
- Adjustable closing & latching speeds.
- Standard Back-check.

Closer Features

- Cast aluminum body.
- Stamped steel arm.
- Stick-on mounting templates optional.
- Plastic Cover Standard.
- Thru-bolts included.
- Non-handed.
- Aluminum (AL) and Duro-Bronze (DB) finishes.

Closer Arm Options

- Cushion Stop Arm - PT-C86-CSA
- Friction Hold Open - PT-C86-FHO

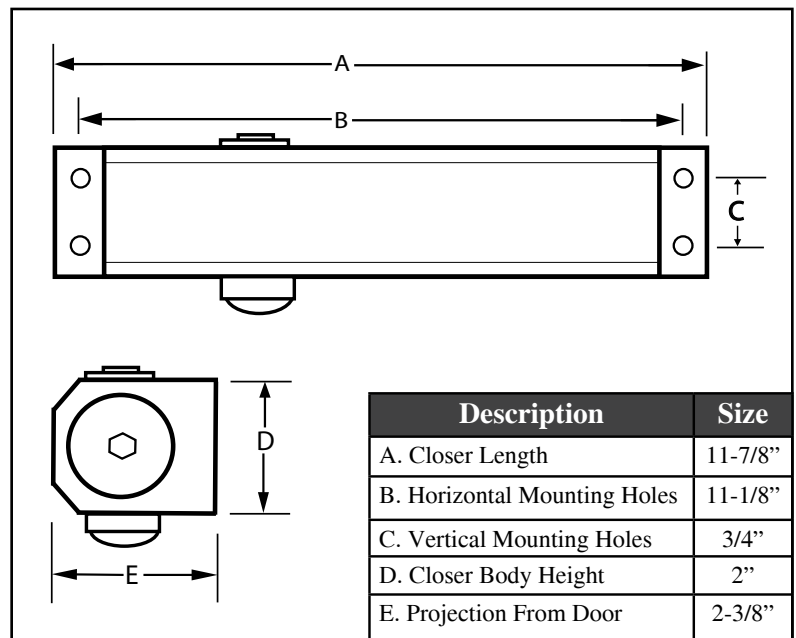

UL LISTED



Meets ADA
Regulations

Competitor Cross References

	Cal-Royal	K2	LCN	Norton	Pamex	Russwin	Sargent	Yale
CL8600	900	QDC200	1460-72G	8501	5600	2820K	1230	3501