

Applications

- Standard-duty surface mounted door closer suitable for moderate traffic & standard door applications.
- Tri-packed for standard, parallel & top jamb installation.
- Interior Door widths to 48 inches.
- Exterior Door widths to 48 inches.
- Door Weights to 250 lbs.

Certifications

- ANSI/BHMA Grade-1.
- UL Listed - Compliant for positive pressure.
- Conforms to UL10C & UBC7-2-1997.
- Independently tested to 2 Million Cycles.

Warranty

- Lifetime Mechanical Warranty.
- Two Year Finish Warranty.

Closer Functions

- Size 1-6 (adjustable).
- Barrier Free.
- Adjustable closing & latching speeds.
- Standard Back-check.

Closer Features

- Cast aluminum body.
- Forged steel arm.
- Stick-on mounting templates optional.
- Plastic Cover optional.
- Thru-bolts included.
- Non-handed.
- Aluminum (AL) and Duro-Bronze (DB) finishes.

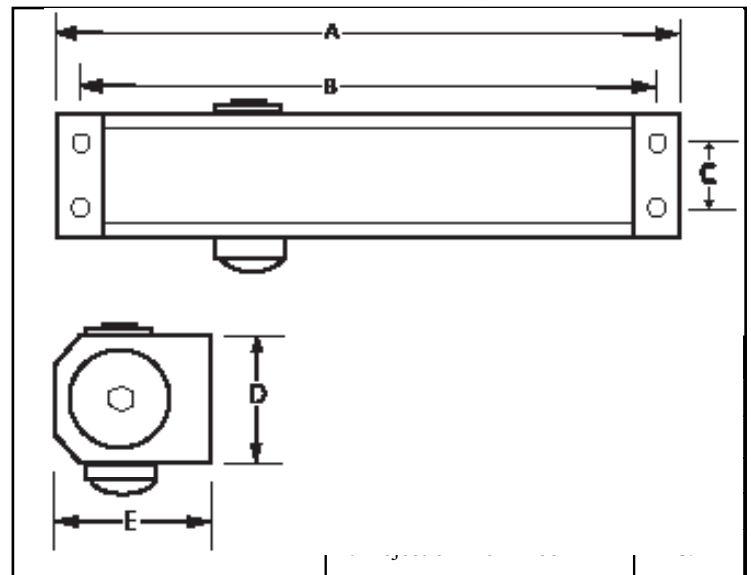

Closer Arm Options

- Cushion Stop Arm - PT-C84-CSA
- Friction Hold Open Arm - PT-C84-FHO



UL LISTED



Meets ADA Regulations

Competitor Cross References

	Cal-Royal	K2	LCN	Norton	Pamex	Russwin	Sargent	Yale
CL8400	300	QDC300	-	1601	8700	-	-	51BF