

Before assembling your chair, watch an assembly video at: www.kyotamassagechairs.com/assembly-tutorials

Alternatively, scan the QR code to go directly to the URL above.



SCAN CODE

1 STEP 1: Carefully check box contents to the detail below, making sure all contents are accounted for.

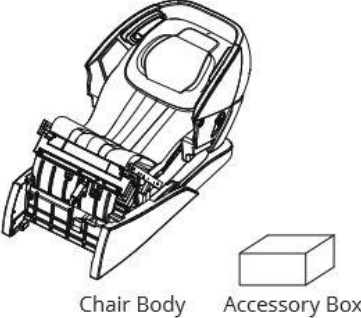

If anything is missing, please contact Kyota Massage Chairs at 800 242-0761. Do not return to the place of purchase.

Box 1:
Chair Body & Accessory Box



Chair Body Accessory Box

Accessory Box

-  Bolt: M8 x 40mm (2 pcs)
-  Bolt: M8 x 16 mm (2 pcs)
-  Washer: M8 x 24 mm (4 pcs)



M8 Hex Key



Spare Clips



Spare Fuse



Power Cord



Phillips Screw Driver



Remote Control

Remote Pouch

Warranty Card

User Manual

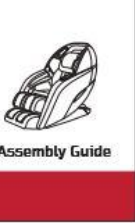

Quick Start Guide

Assembly Guide

Box 2:
Arm Panels (2)

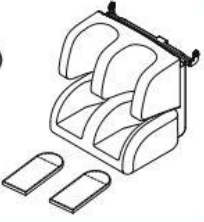

Box 3:
Footrest (1)
Foot Pads (2 pcs)



5 Step 5: Carefully lift each arm panel and place the arm panel hook on the chair body rail to support the arm panel. Make sure the air hoses and electrical wires remain connected and not pinched.

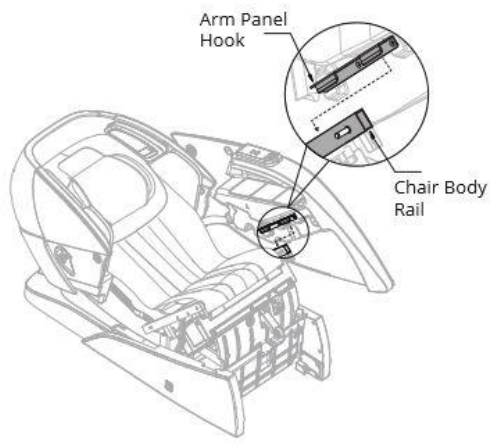

7 Step 7: Locate the long, silver M8 Bolts (2), Washers (2) and hex key tool from the Accessory Box. Fasten this bolt and washer under the Velcro flap just below the shoulder air bag (Position B) until snug; do not tighten yet.

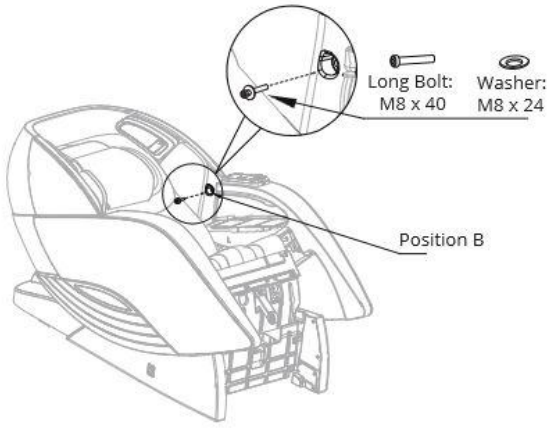

9 Step 9: Locate the power cord, remote pouch and remote control from the Accessory Box. Plug the power cord into the power cord port on the back side of the base of the chair. Attach the velcro from the back of the remote pouch to the velcro strip located on the underside of the right arm panel.

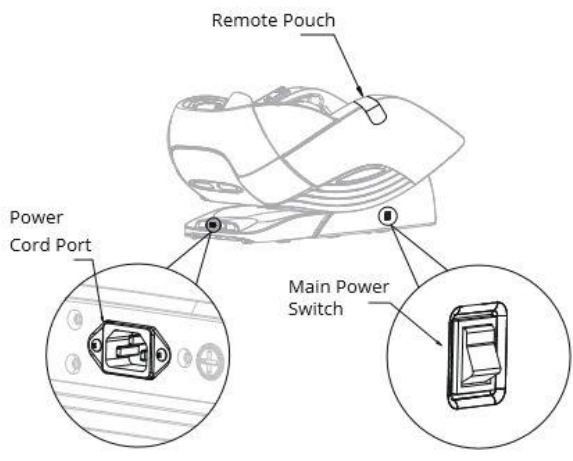

2 Step 2: Place the chair body on a soft surface for assembly. Determine the left arm panel from the right and place next to the correct side of the chair.

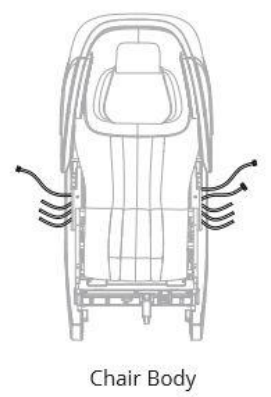

3 Step 3: Note the 3 locations each arm panel attaches to the chair body; locations A, B and C.

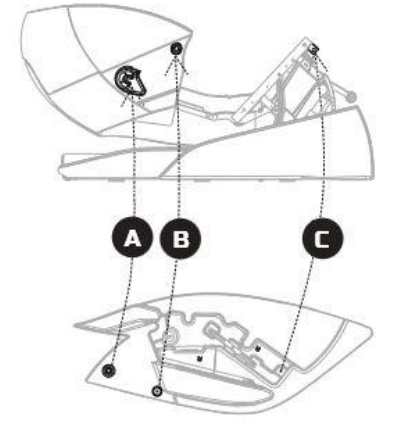

4 Step 4: Locate the air hoses off each side of the chair body and note that each hose has a number. Locate the corresponding number on the air hose nozzles of each arm panel. Firmly connect the hoses to the nozzles by matching the numbers on each.

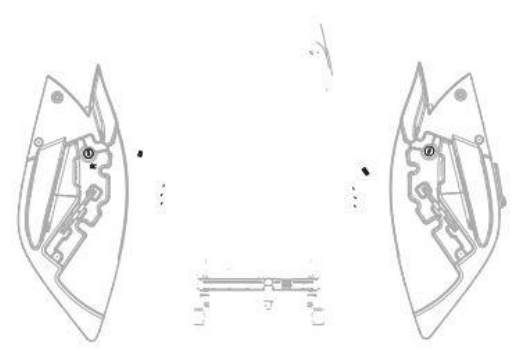

Locate the electrical plugs off the chair body. One wire on the right side and two wires on the left side. Firmly clip each into the corresponding electrical port.

6 Step 6: Next, locate the Pin in position A on the arm panel and secure it under the pin retainer on the chair body in position A from step 3. Make sure that the hook and the pin are firmly in place before moving onto the next step.



8 Step 8: Locate the shorter, black M8 Bolts (2) and Washers (2) from the Accessory Box. Fasten this bolt and washer in Position C. When secured, tighten both positions C and B on both arms.

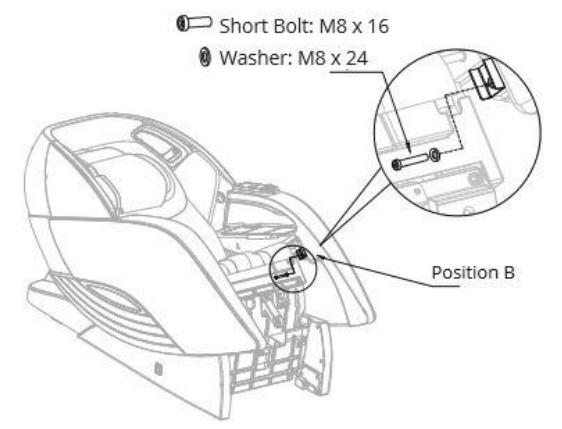

10 Step 10: Plug the remote control cord into the remote control port located on the front right of the chair body and fasten. Ensure the arrow on the remote control cord lines up with the arrow on the remote control port before inserting. Screw on metal ring to fasten. Do not force.

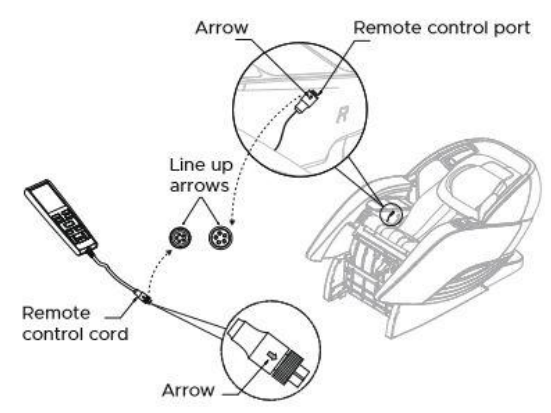

11 Step 11: Connect the power cord to a grounded 110V electrical outlet. Power on the main power switch on the side of the chair body. Press the red power button on the remote control, once to turn it on and once more to bring the chair into an upright position. Locate Footrest and position it in front of the main chair body.

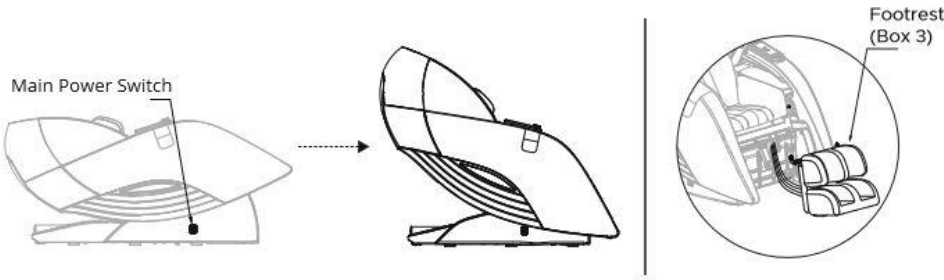

12 Step 12: Unplug chair from electrical source. Connect the footrest by attaching the three electrical plugs from the footrest into their respective ports on the body of the chair. Ensure the thumb release is facing up and push in until it clips. Slide the air hose onto the air nozzle.

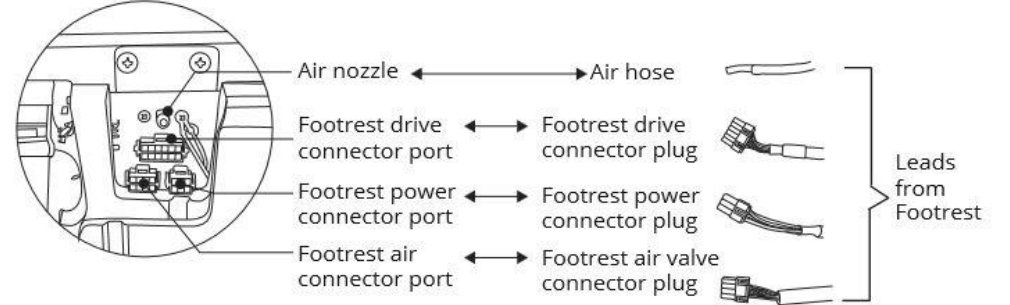

13 Step 13: Before attaching the footrest to the chair body, remove the clips on the chair body pins by sliding up. (If Clips are missing, there are spare clips in the Accessory Box)

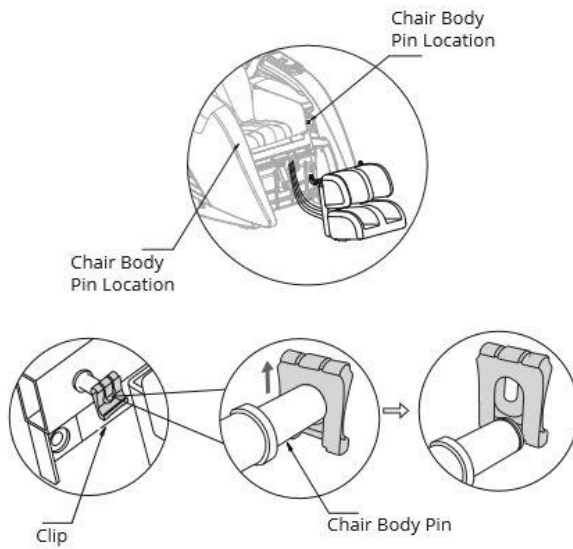

14 Step 14: Lift the footrest and slide one side of the footrest hinge completely onto the corresponding chair body pin. To secure, fasten clip over chair body pin by sliding on. Carefully align the other footrest hinge over the remaining chair body pin and center the footrest. Fasten the remaining clip over the chair body pin to secure both sides of the footrest.

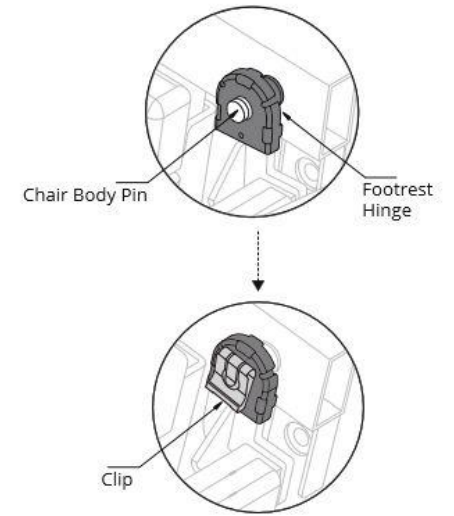

Final Check:

Double check that all air hoses are still firmly connected in the back of the chair under the arm panels. You can see the connections in the back of the chair, underneath the arm panels when fully upright.

Plug the chair back into a grounded 110V electrical outlet.

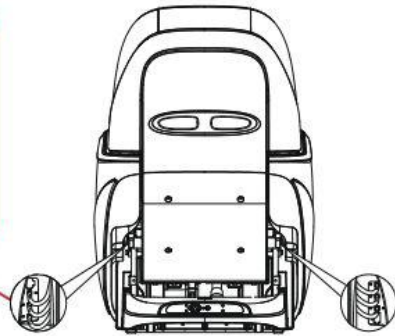

Zipper the closure between the Footrest and Chair Body

Ensure the Footrest assembly swings freely up and down, Electrical connections are firmly attached, and air hoses are secure. Remove the foot pads to increase foot roller intensity, if desired.

Turn on Main power switch



Power on the remote and select AUTO program to start a session.

Review chair for smooth operation. If things are not operating correctly, review all assembly steps. Call Kyota support at 800-242-0761 if you need live US-based support.

You are done; time for a Massage!

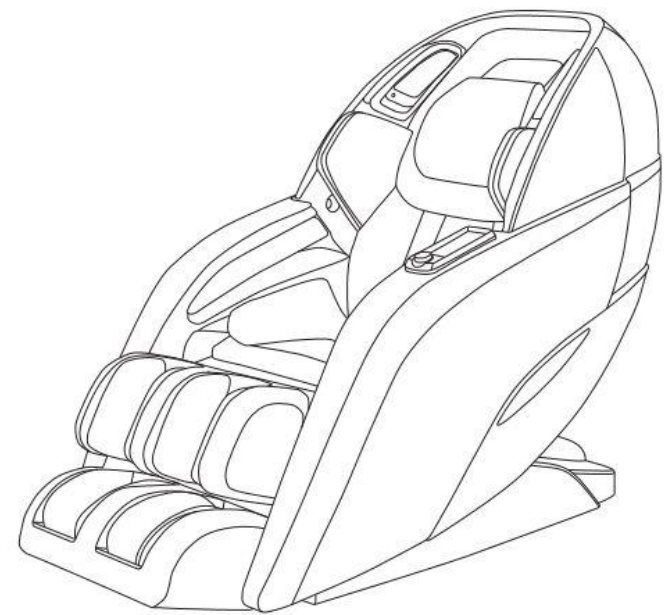

Register your product at www.kyotamassagechairs.com/warranty/registration to ensure it is in our system. This will simplify the warranty process should you ever need it.

Alternatively, scan the QR code to go directly to the URL above.

Assembly Guide

Yutaka M898 4D Massage Chair