

## Hugi B1602 Basin

### Notes:

- Wall Hung
- Polymarble or solid surface composition
- 10 years manufacturers warranty

### Finishes:

- Matte white
- Gloss white
- Full colour range

### Options:

Stone waste  
(matte white)



**Size:** 620 L x 480 W x 130 H (mm)

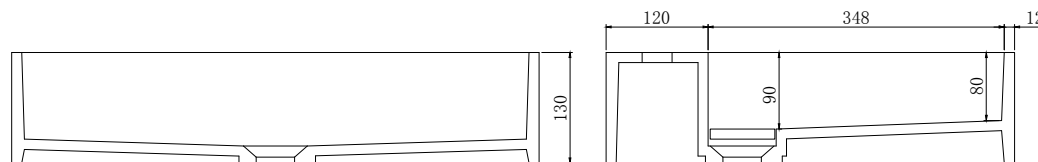
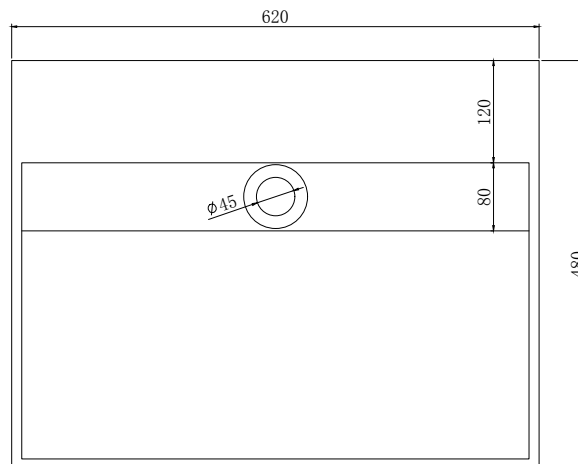

Net weight: 18kg  
Gross weight: 20kg  
Unit: mm