

Hugi B1515-2 Basin

Notes:

- Benchtop
- Polymarble or solid surface composition
- 10 years manufacturers warranty

Finishes:

- Matte white
- Gloss white
- Full colour range

Options:

- Stone waste
(matte white)



Size: 250 L x 250 W x 110 H (mm)

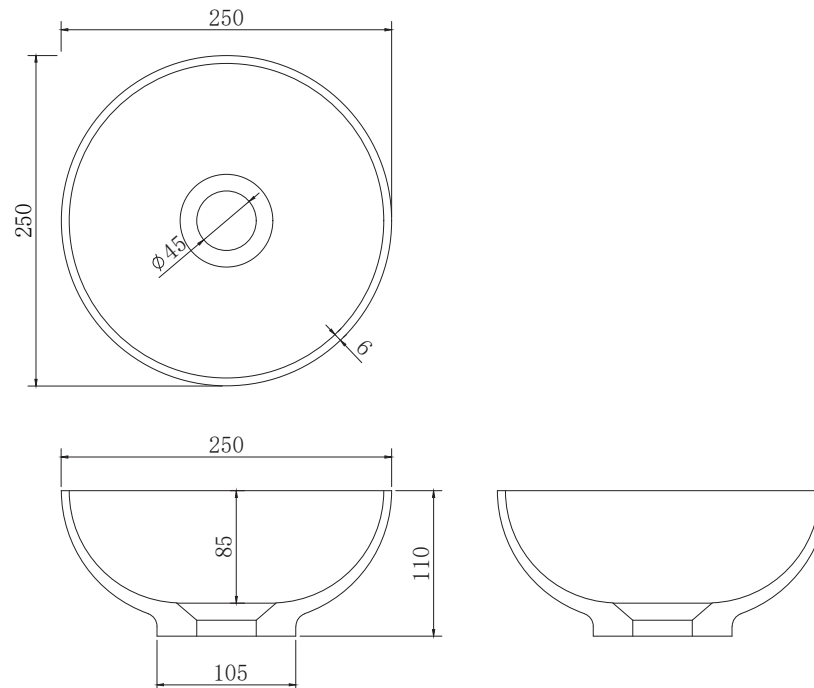

Net weight: 2.7kg
Gross weight: 4kg
Unit: mm