

Hugi B1105-B Basin

Notes:

- Wall Hung
- Polymarble or solid surface composition
- 10 years manufacturers warranty

Finishes:

- Matte white
- Gloss white
- Full colour range

Options:

- Stone waste (matte white)

Size: 355 L x 200 W x 160 H (mm)

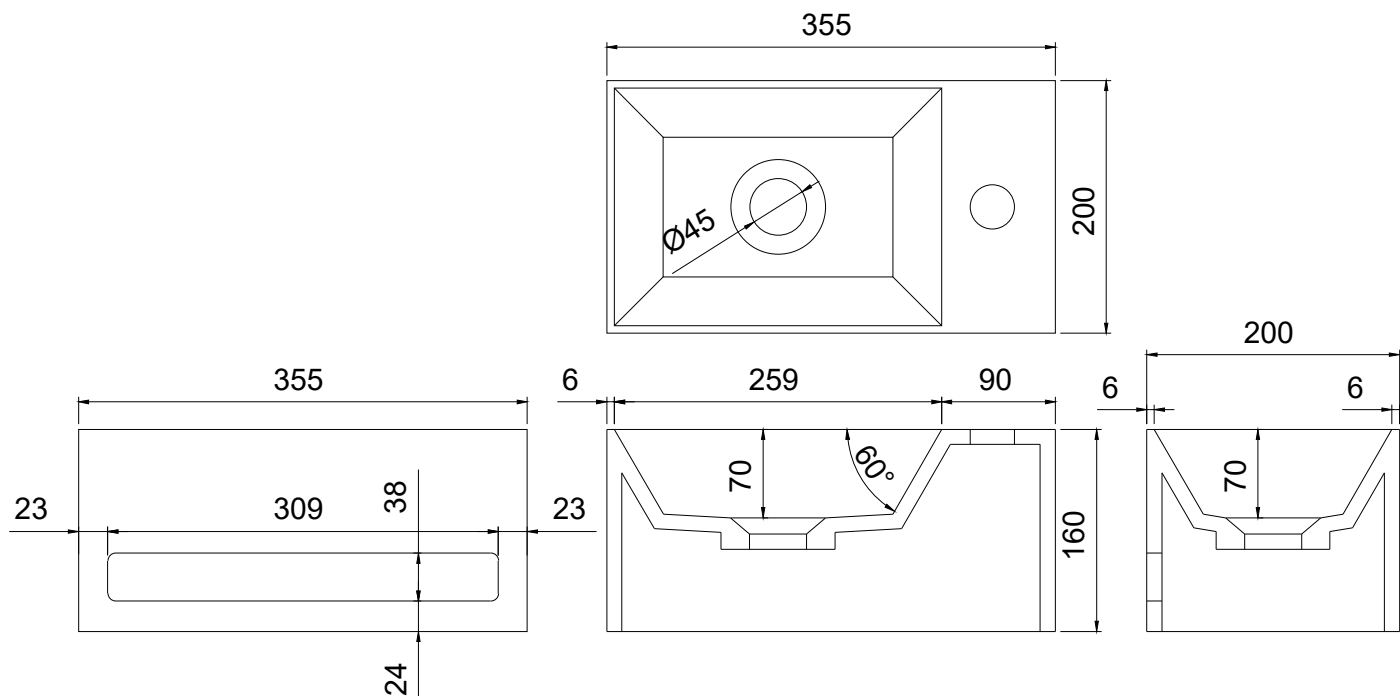

Net weight: 6.5kg
 Gross weight: 8.5kg
 Unit: mm